

# INDUSTRIAL AND COMMERCIAL VENTILATION

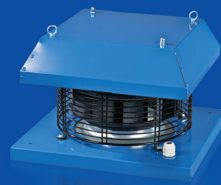
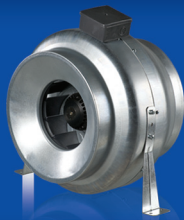
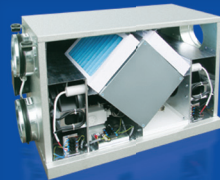

 **VENTS**

2010

*Fresh air in  
your house!*

<b>Catalogue section</b>	<b>Page</b>
Contents .....	2
Quick fan selection.....	6
Quick selection of air handling units.....	7
About us.....	8
Ventilation in our life.....	10
System of round ducts.....	18
Round duct fans.....	20
System of rectangular ducts.....	62
Rectangular duct fans.....	64
Chimney centrifugal fans.....	84
Sound-insulated fans.....	92
Centrifugal fans.....	110
Axial fans.....	126
Roof fans.....	140
Supply and exhaust units.....	156
Air Handling units with heat recovery.....	182
X-Vent in-line units.....	218
AirVents Air handling units.....	220
Air-Heating units.....	226
Accessories.....	236
Electrical accessories.....	306
Fan wiring diagrams.....	326
Alphabetical index.....	336



## ROUND DUCT FANS



**VENTS TT**  
Duct mixed-flow fan

page  
**22**



**VENTS VK**  
Duct centrifugal fan

page  
**32**



**VENTS VK VMS**  
Multiple-inlet centrifugal fan

page  
**36**



**VENTS VKM**  
Duct centrifugal fan

page  
**38**



**VENTS VKMz**  
Duct centrifugal fan

page  
**42**



**VENTS VC**  
Duct centrifugal fan

page  
**46**

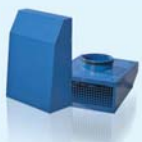

**VENTS VCN**  
Exhaust centrifugal fan

page  
**50**



**VENTS VKP**  
Duct centrifugal fan

page  
**54**



**VENTS VKP**  
Mini in-line centrifugal fan

page  
**56**

## RECTANGULAR DUCT FANS



**VENTS VKPF**  
Duct centrifugal fan

page  
**66**



**VENTS VKPFI**  
Duct centrifugal heat- and sound-insulated fan

page  
**66**



VENTS VKPF with EC-motor  
**VENTS VKP EC**  
Duct centrifugal fan

page  
**74**



**VENTS VKP**  
Duct centrifugal fan

page  
**78**



**VENTS VKPI**  
duct centrifugal heat- and Sound-insulated fan

page  
**78**

## CHIMNEY CENTRIFUGAL FANS



**VENTS KAM**  
Chimney centrifugal fan

page  
**86**

## SOUND-INSULATED FANS



**VENTS VS**  
Sound-insulated fan

page  
**94**



**VENTS KSA**  
Sound-insulated fan

page  
**100**



**VENTS KSB**  
Sound-insulated fan

page  
**104**

## CENTRIFUGAL FANS



**VENTS VCU**  
Scroll fan

page  
**112**



**VENTS VCUN**  
Scroll fan

page  
**116**

## AXIAL FANS



**VENTS OV**  
Axial fan

page  
**128**



**VENTS OVK**  
Axial fan

page  
**128**



**VENTS VKF**  
Axial fan

page  
**128**



**VENTS OV1**  
Axial fan

page  
**134**



**VENTS OVK1**  
Axial fan

page  
**134**



**VENTS VKOM**  
Axial fan

page  
**134**

## ROOF FANS



**VENTS VKV**  
Centrifugal roof fan

page  
**142**



**VENTS VKH**  
Centrifugal roof fan

page  
**142**



**VENTS VKMK**  
Centrifugal roof fan

page  
**148**

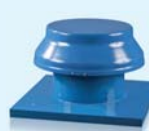

**VENTS VOK**  
Axial roof fan

page  
**150**

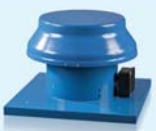

**VENTS VOK1**  
Axial roof fan

page  
**152**

## SUPPLY AND EXHAUST UNITS



**VENTS VPA**  
Series supply units

page  
**158**



**VENTS MPA...E**  
Series supply units

page  
**162**



**VENTS MPA...W**  
Series supply units

page  
**162**



**VENTS PA...E**  
Series supply units

page  
**172**



**VENTS PA...W**  
Series supply units

page  
**172**



**VENTS VA**  
Series supply units

page  
**180**

## AIR HANDLING UNITS WITH HEAT RECOVERY



**VENTS VUT mini**  
Air Handling unit with heat recovery

page  
**188**



**VENTS VUT mini with EC-motor**  
Air Handling unit with heat recovery

page  
**190**



**VENTS VUT H**  
Air Handling unit with heat recovery

page  
**192**



**VENTS VUT H with EC Motor**  
Air Handling unit with heat recovery

page  
**196**



**VENTS VUT EH and VENTS VUT WH**  
Air Handling units with heat recovery

page  
**198**



**VENTS VUT EH** Air Handling units with heat recovery **with EC motor** and **VENTS VUT WH with EC motor**

page  
**204**



**VENTS VUT PE** Air Handling units with heat recovery **with EC motor** and **VENTS VUT PW with EC motor**

page  
**210**

## X-VENT ENERGY-SAVING IN-LINE UNITS



**X-VENT**  
Energy-saving in-line units

page  
**218**

## AIRVENTS AIR-HANDLING UNITS



**AIRVENTS**  
Air-handling units

page  
**220**

## AIR-HEATING UNITS



**AOW**  
Air-heating units with water heat exchanger

page  
**228**



**PVZ**  
Air curtains

page  
**232**

## ACCESSORIES

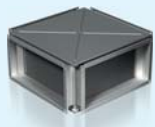

**PR**  
Plate heat exchangers

page  
**238**



**SR, SRF, SRP, SRN**  
Silencers

page  
**240**



**FB, FBV**  
Filter cassettes

page  
**248**



**FBK**  
Pocket filters

page  
**250**



**NK, NKW**  
Heaters

page  
**254**



**USWK**  
Mixing sets

page  
**280**



**OKW, OKF**  
Coolers

page  
**282**



**KOM, KOM1**  
Dampers

page  
**294**



**KR, KRA**  
Shutoff dampers

page  
**296**

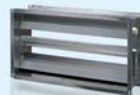

**RRV, RRVA, RRVAF**  
Air flow regulators

page  
**298**



**KG**  
Gravitation backdraft dampers

page  
**300**

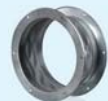

**VVG**  
Flexible connectors

page  
**301**



**SKRA**  
Mixing sections

page  
**302**



**CZK, CZ, C, CB, CBR**  
Clamps

page  
**304**

## ELECTRICAL ACCESSORIES



**RS series**  
Thyristor speed controllers

page  
**310**



**RSA series**  
Transformer speed controllers

page  
**314**



**VFED series**  
Frequency speed controllers

page  
**319**



**RTS series, RTSD series, RT series**  
Temperature regulators

page  
**320**



**P2, P3, P5 series**  
Speed switches

page  
**322**



**R series**  
EC-motors regulators

page  
**324**



**T series, TH series, TF series, TP series**  
Sensors

page  
**325**



## QUICK FAN SELECTION

For the detailed fan selection program please refer [www.ventilation-system.com](http://www.ventilation-system.com)

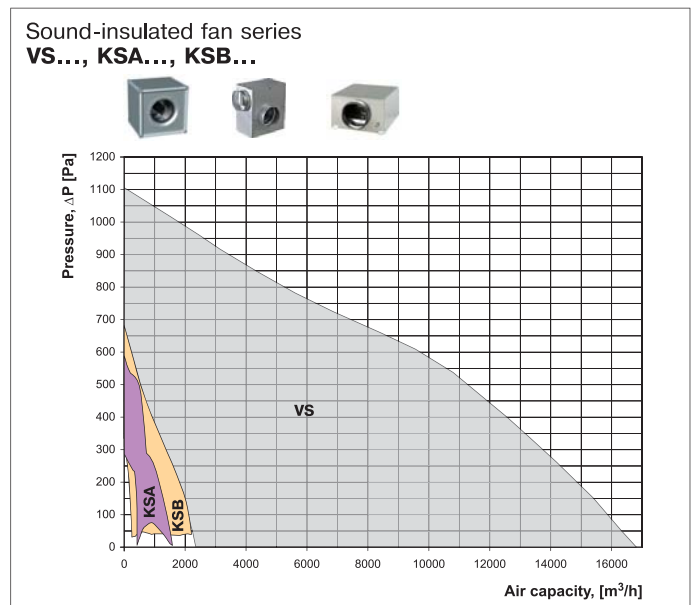
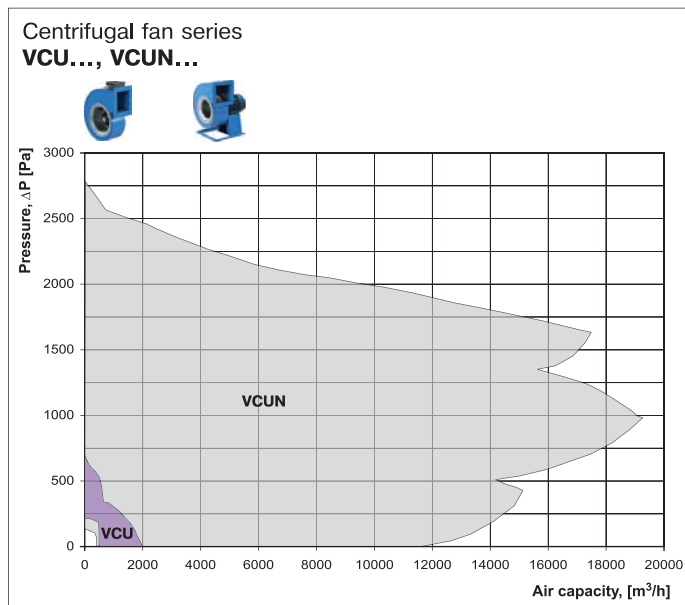
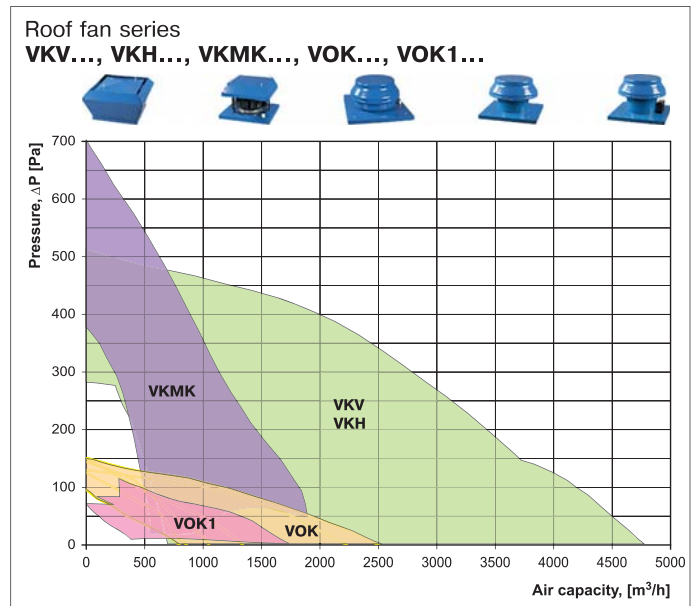
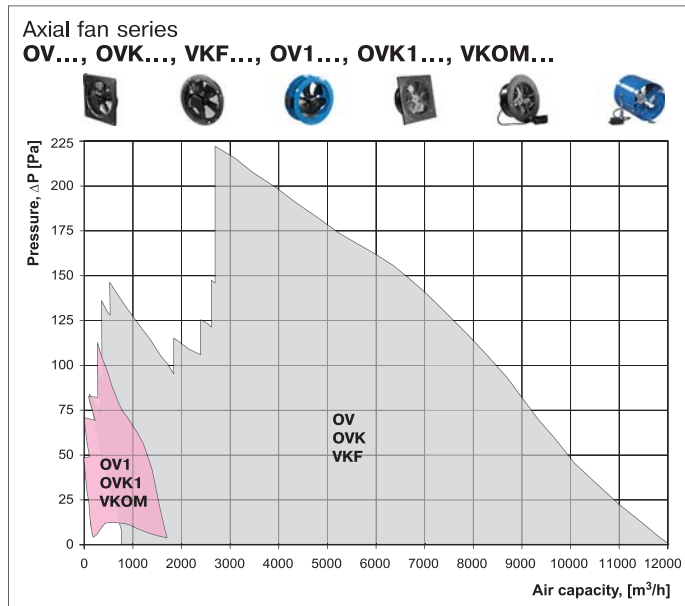
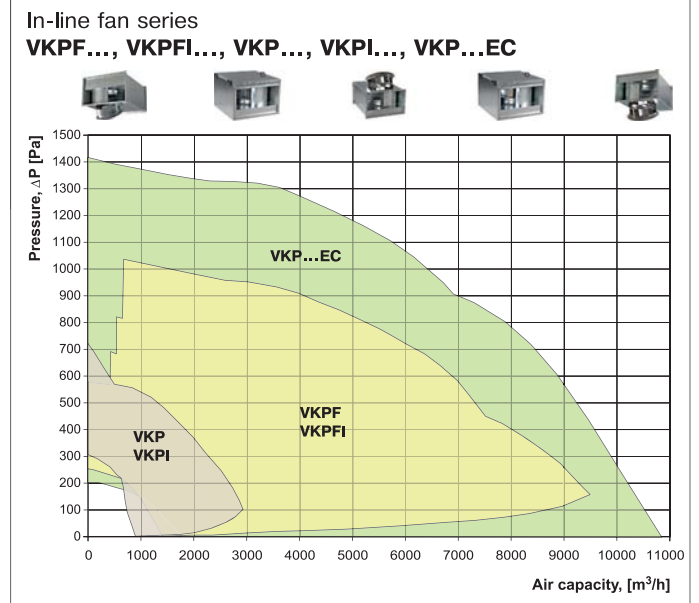
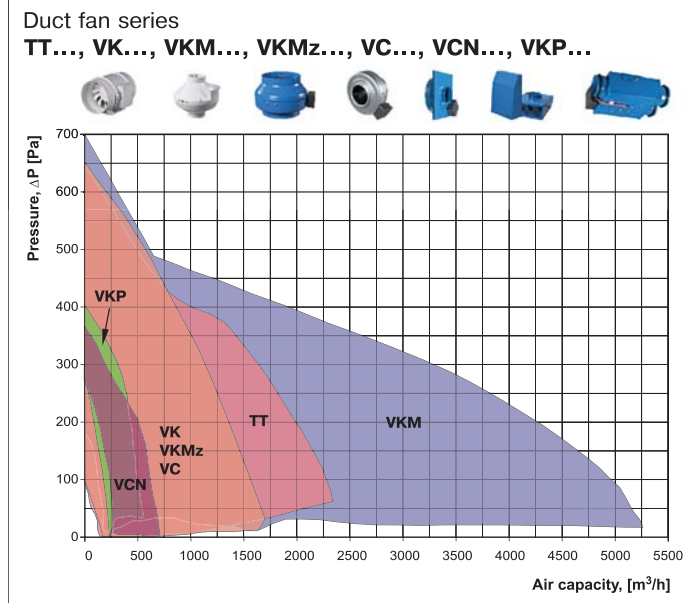

## QUICK SELECTION OF AIR HANDLING UNITS

### VPA..., MPA..., PA..., VA... series supply and exhaust units

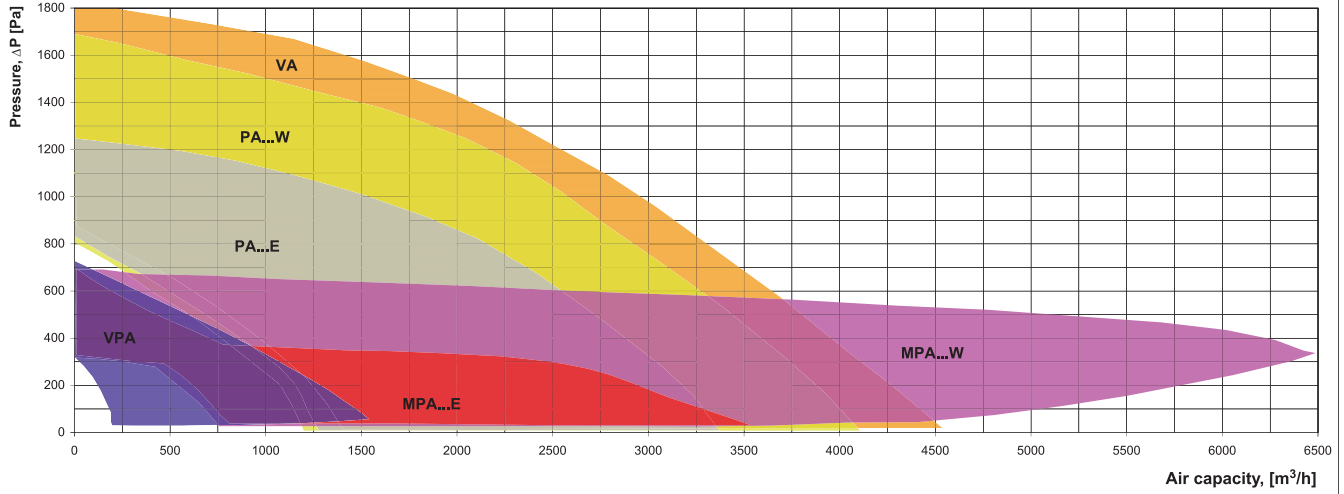

### VUT series air handling units with heat recovery

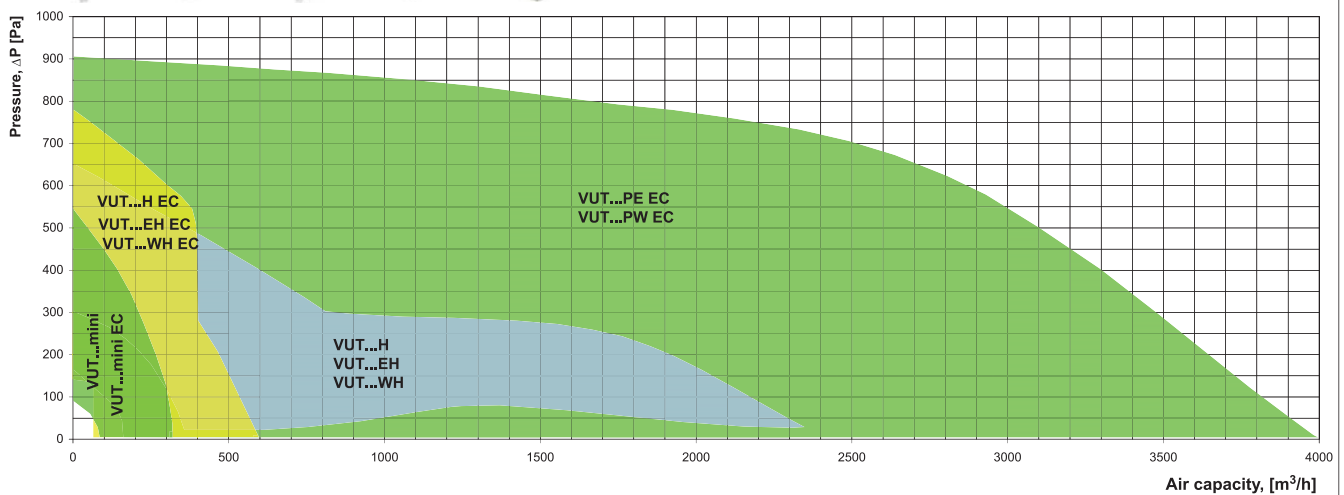

### Series of air handling units with heat recovery

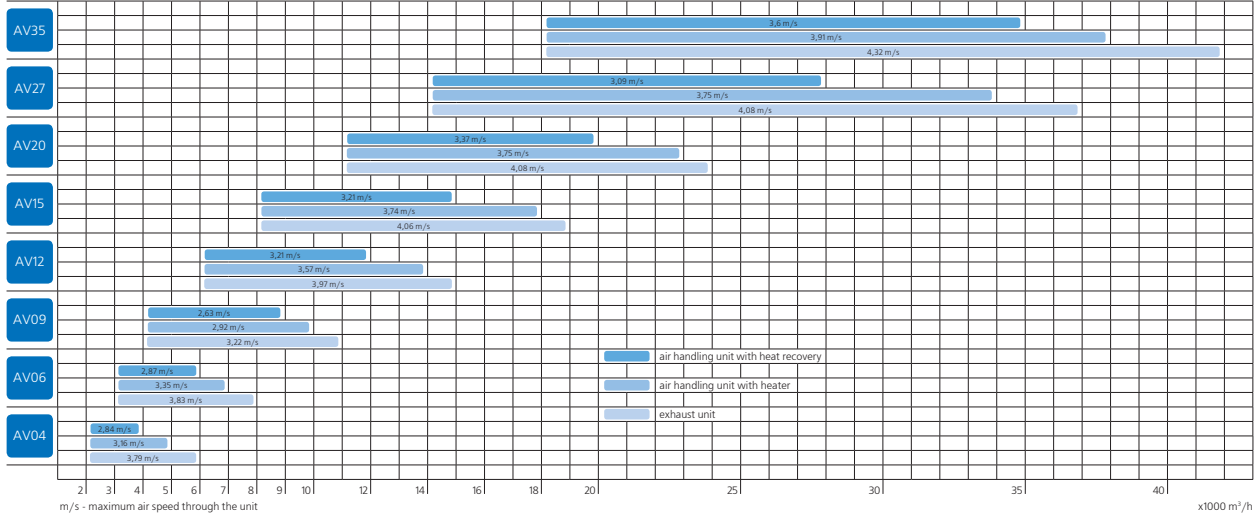
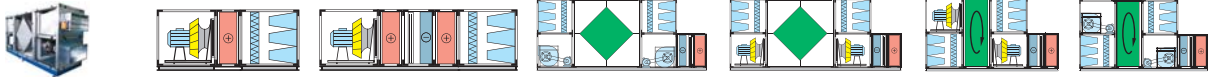

## ■ WELCOME TO THE VENTS WORLD!

VENTS company was founded in the 90th years of the XXth century. Dynamic development of the enterprise and never-ending study of consumer demand enabled rapid international leadership in the ventilation industry.

VENTS company is one of few companies to manufacture independently a wide range of products for development of ventilation systems of any complexity.

VENTS is a powerful research and development enterprise with approximately 2000 staff ensuring full production cycle from idea to end product. The production base of the company is located at more than 60 000 m<sup>2</sup> area. It includes 12 workshops equipped under the international standards and each of them performs the function of a separate plant.

Modern equipment, active adoption of advanced technologies and high level of manufacture automation are the characteristic features of VENTS company.

The company undergoes progressing development; fundamental researches and effective designs in climatic equipment industry are in the focus of the company's business strategy.

Own design department, test laboratories and production workshops enable supplying the products of high quality to market.

Special attention is paid to the manufacturing of the goods during all manufacturing stages including monitoring the technological conditions. Technical characteristics of supplied raw materials are thoroughly checked. Quality control system which meets international standard requirements ISO 9001:2000 was implemented at the enterprise.

Environmental protection is one of the basic components for the corporate development. The whole technological process at the enterprise is arranged in such a way as to exclude any negative impact for the environment. To solve the global energy saving problem we develop special climatic equipment ensuring comfort conditions for people and reducing the energy consumption significantly.







Metal workshop



Injection Molding workshop



Extrusion workshop



Domestic fan workshop



Plastic grille workshop



Commercial fan workshop



Industrial fan workshop



Air handling units workshop



Spiral wound ducts workshop



Flexible Ducts workshop

VENTS is the only exporter of ventilation equipment in Ukraine. Our goods gained consumers' acceptance in more than 80 countries of the world including the countries of Europe, America, Asia and Australia that confirms the company reliability and excellent quality of the products. Since 2008 our company is the only Ukrainian manufacturer being the member of the USA Ventilation and Conditioning Association HARDI. Worldwide recognition witnessed that VENTS is the leader of the world ventilation market.



**Cooperation with VENTS TM provides you with the maximum range of products of the top quality from one manufacturer.**



# VENTILATION IN OUR LIFE



## ▶ What Is Ventilation?

Ventilation is a complex of actions and facilities used for air exchange arrangement to provide the specified air condition in the premises and in working places.

Ventilation systems maintain admissible meteorological parameters in various premises. Ventilation system should create the internal atmosphere that meets the specified hygienic standards and technological requirements.

## ▶ What Is Ventilation Required For?

We are surrounded with air and breathe in and out 20 000 litres of air every day. How much healthy is the air we breath in? There is a range of aspects to determine air quality.

- ▶ **Oxygen and Carbon Dioxide Concentration In the Air.** Oxygen decrease and carbon dioxide cause stuffiness in the premises.
- ▶ **Content of Harmful Substances and Dust In the Air.** High content of dust, tobacco smoke and other substances in the air are harmful for the human organism and can cause various lung and skin diseases.
- ▶ **Odours.** Bad smell causes discomfort or irritates nervous system.
- ▶ **Air Humidity.** Increased or decreased moisture cause discomfort and even can result in acute attacks of disease for sick people. Air humidity is important also for the internal atmosphere. For instance, doors, window frames, furniture may dry up of decreased humidity in winter; but in the premises with increased humidity (e.g. in swimming-pools, bathrooms) they can expand.
- ▶ **Air Temperature.** A person feels comfortable in a premise with the temperature 21-23°C. Temperature variation causes the change of «comfort» well-being more or less that influences a person's physical and mental activity.
- ▶ **Air Motion.** Increased air speed in the premises causes the feeling of draft, and decreased speed causes air blanketing. Being inside we feel the impact of any of these factors.

## ▶ Ventilation system arrangement

Properly arranged ventilation system is the only solution in this situation. It provides filtered air supply in summer and filtered and warmed outdoor air in winter as well as extract stale air removal from the premises.

Any ventilation system must include simultaneous fresh air supply and extract air exhaust thus ensuring the ideal air balance in the room. In case of poor or insufficient air intake from outside the oxygen content decreases, humidity and dustiness level increase. If exhaust ventilation is not provided or it is not effective, polluted air, smells, humidity and harmful substances are not removed.

One more important factor for properly arranged ventilation system is joint operation of supply and exhaust air vents. Take into account that with the only air vent (e.g. only exhaust fan is mounted in the bathroom unit), air flows from all possible gaps in windows, doors and walling. Such air supply leads to dust ingress, smells in the premises and drafts.

Natural sources of the organized air supply for making compensation to the exhausted air may serve vent grids mounted in doors of the bathroom unit, wall or window vents, opened ventlights, windows. Otherwise it may be the system of artificial ventilation when air flows to the premises in a centralized way.

## ▶ Calculation of the required air exchange.

### Engineering recommendations

#### Calculation of Air Exchange According to Air Exchange Rate:

Ventilation air volume is determined for each premise separately taking into account harmful impurities (substances) or it is specified on the basis of researches. If the nature and number of harmful impurities (substances) cannot be counted, air exchange is determined with the formula:

$$L = V_{\text{prem.}} \cdot \text{Ach} \quad [\text{m}^3/\text{h}],$$

where  $V_{\text{prem.}}$  – air space [ $\text{m}^3$ ];

$\text{Ach}$  – minimum air exchange per hour, see air exchange table.

**How to determine the premise volume?**

Use a simple formula:

**length x width x height = volume of the premises m<sup>3</sup>**

$$A \times B \times H = V \text{ [m}^3\text{]}$$

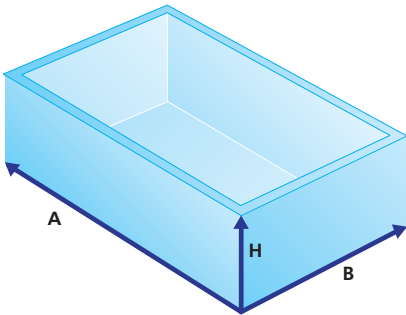

Example: the premise with 7 m length, 4 m width and 2.8 m height. To determine the air volume required for ventilation of this premises, calculate the volume of the room: 7x4x2.8=78.4 m<sup>3</sup>. After that determine the required efficiency of the fan using the following tables of recommended ventilation rate.

**Calculation of air exchange according to the number of people in the premises:**

$$L = L_1 * N_1 \text{ [m}^3\text{/hour]},$$

where **L<sub>1</sub>** – rated value for air volume per one person, m<sup>3</sup>/hour\*person;  
**N<sub>1</sub>** – number of people in the premises

20-25 m <sup>3</sup> /hour per one person at low physical activity
45 m <sup>3</sup> /hour per one person at light physical activity
60 m <sup>3</sup> /hour per one person at heavy physical activity

**Calculation of air exchange with moisture evaporation:**

$$L = \frac{D}{(d_v - d_n) * \rho} \text{ [m}^3\text{/hour]}$$

where **D** – moisture, g/hour;  
**d<sub>v</sub>** – moisture content in the exhaust air, gram of water/kg of air;  
**d<sub>n</sub>** – moisture content in the intake air, gram of water/kg of air;  
**ρ** – air density, kg/m<sup>3</sup> (at 20°C = 1,205 kg/m<sup>3</sup>);

**Calculation of air exchange to remove excessive heat:**

$$L = \frac{Q}{\rho * C_p * (t_v - t_n)} \text{ [m}^3\text{/hour]}$$

**Q** – heat release in the premises, kW;  
**t<sub>v</sub>** – exhaust air temperature, °C;  
**t<sub>n</sub>** – intake air temperature, °C;  
**ρ** – air density [kg/m<sup>3</sup>] at 20°C = 1,205 kg/m<sup>3</sup>;  
**C<sub>p</sub>** – heat capacity of air [kJ/(kg.K)] at 20°C; C<sub>p</sub>=1,005 kJ/(kg.K)

**Air ventilation rate:**

Premise	Air exchange rate	
Domestic premises	Living room of apartments or hostel residential premises	3 m <sup>3</sup> /h for 1 m <sup>2</sup> in residential premises
	Kitchen in flat or hostel	6-8
	Bathroom	7-9
	Shower cabin	7-9
	WC	8-10
	Home laundry room	7
	Cloakroom	1,5
	Storeroom	1
	Garage	4-8
	Cellar	4-6
Industrial premises and large premises	Theatre, cinema, conference hall	20-40 m <sup>3</sup> per each visitor
	Office	5-7
	Bank	2-4
	Restaurant	8-10
	Bar, café, pub, billiard room	9-11
	Professional kitchen	10-15
	Supermarket	1,5-3
	Chemist's	3
	Garages and vehicle repair shops	6-8
	Public WC	10-12 (or 100 m <sup>3</sup> per each WC pan)
	Dance Halls and disco clubs	8-10
	Smoking rooms	10
	Server rooms	5-10
	Sport hall	80 m <sup>3</sup> or more for each sportsman and 20 m <sup>3</sup> or more for each viewer
	Hair dresser's	
	Up to 5 working places	2
	More than 5 working places	3
	Warehouses	1-2
	Laundryroom	10-13
	Swimming pool	10-20
Industrial painting shop	25-40	
Machine shop	3-5	
School classroom	3-8	

**Calculation of air exchange depending upon maximum permissible concentration of aggressive substances in the air:**

$$L = \frac{G_{CO_2}}{y_{ndk} - y_n} \text{ [m}^3\text{/hour]}$$

**G<sub>CO<sub>2</sub></sub>** –CO<sub>2</sub> release amount [l/hour],  
**y<sub>ndk</sub>** – CO<sub>2</sub> maximum permissible concentration, l/m<sup>3</sup>,  
**y<sub>n</sub>** – gas content in the intake air, l/hour.

## CO<sub>2</sub> permissible concentration norms, l/m<sup>3</sup>

Permanent residential premises	1,0	
Hospitals and child care centers	0,7	
Periodically occupied premises	1,25	
Short stay premises	2,0	
Open air:	Populations centers (village)	0,33
	Small towns	0,4
	Big cities	0,5

### ► What is pressure loss?

Air resistance in ventilation system is mainly determined by air speed in this system. Resistance grows as the air speed increases. This phenomenon is called pressure loss. Static pressure, produced by a fan, causes air motion in the ventilation system with a certain resistance. The higher the resistance of such a system is, the less air capacity moved by the fan is. Calculation of friction losses for air in air ducts, as well as resistance of the networking equipment (a filter, silencer, heater, valves and dampers, etc.) can be performed with help of tables and diagrams mentioned in the catalogue. The general pressure loss is equal to the total amount of all the resistance indices of all the elements in the ventilation system.

### Recommended air motion speed rate inside the air ducts:

Type	Air speed, m/s
Main air ducts	6,0 - 8,0
Side branches	4,0 - 5,0
Air distribution ducts	1,5 - 2,0
Intake ceiling grilles	1,0 - 3,0
Extract grilles	1,5 - 3,0

### Calculation of air speed in the air ducts:

$$V = \frac{L}{3600 \cdot F} \quad (\text{m/s})$$

L – air capacity [ m<sup>3</sup>/hour];

F – duct cross section [m<sup>2</sup>];

### Recommendation 1.

Pressure loss in the duct system can be reduced due to larger duct section which

provides relatively equal air speed in the whole system. The figure below shows how to provide relatively equal air speed in the duct system with the minimum pressure loss.

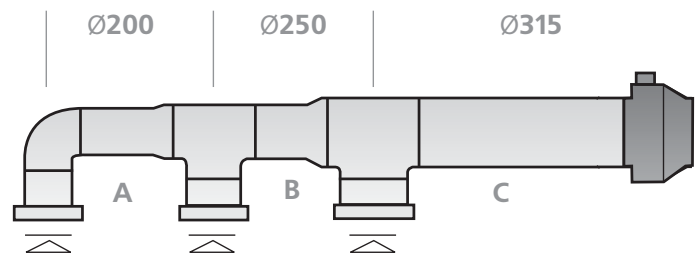

### Recommendation 2.

The systems with large air duct length and large number of grilles should incorporate a fan in the middle of the ventilation system. Such solution has several advantages. On the one hand, pressure losses are reduced, on the other hand, smaller ducts are used.

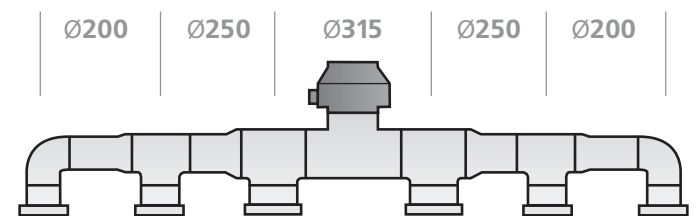

### Ventilation system calculation example:

Start the calculation with the system drafting, showing the location of the air duct, ventilation grilles, fans and also the air duct section lengths between T-joint. Then calculate the air capacity at each section.

To calculate the pressure loss in the sections 1-6, use the pressure loss diagram for round air ducts. For that the required air duct diameters and pressure loss shall be determined under condition of permissible air speed in the duct.

**Section 1:** air capacity is 200 m<sup>3</sup>/h. On the assumption that the air duct diameter is 200 mm, air speed is 1.95 m/s the pressure loss makes 0.21 Poa/m x 15 m = 3 Pa (refer to the pressure loss diagram in the air ducts).

**Section 2:** the same calculations shall be performed considering that the air speed through this section makes 220+350=570 m<sup>3</sup>/h. On the assumption that the air duct diameter is 250 mm and the air speed is 3.23 m/s the pressure loss value makes 0.9 Pa/m x 20 m = 18 Pa.

**Section 3:** air capacity through this section makes 1070 m<sup>3</sup>/h. On the assumption that the air duct diameter is 315 mm and the air speed is 3.82 m/s the pressure loss value makes 1.1 Pa/m x 20 m = 22 Pa.

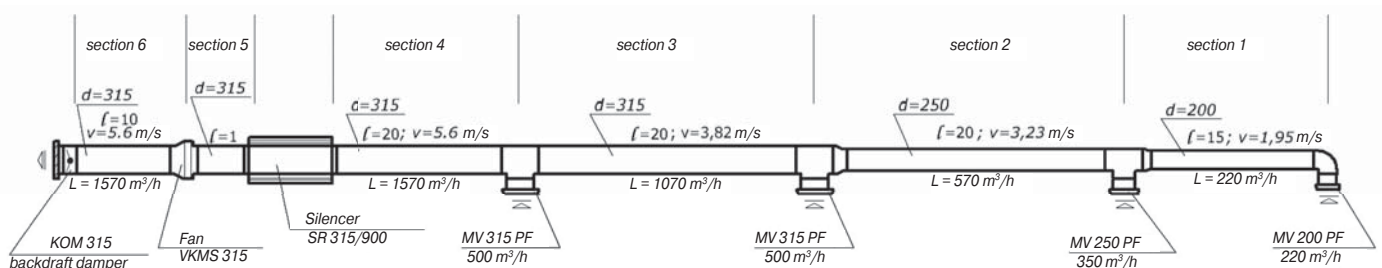

**Section 4:** air capacity through this section makes 1570 m<sup>3</sup>/h. On the assumption that the air duct diameter is 315 mm and the air speed is 5.6 m/s the pressure loss value makes 2.3 Pa/m x 20 m = 46 Pa.

**Section 5:** air capacity through this section makes 1570 m<sup>3</sup>/h. On the assumption that the air duct diameter is 315 mm and the air speed is 5,6 m/s the pressure loss value makes 2.3 Pa/m x 20 m = 2.3 Pa.

**Section 6:** air capacity through this section makes 1570 m<sup>3</sup>/h. On the assumption that the air duct diameter is 315 mm and the air speed is 5.6 m/s the pressure loss value makes 2.3 Pa x 10 m = 23 Pa. The total pressure loss in the air duct makes 114.3 Pa.

As the last section pressure loss calculation is over calculate the pressure loss in the network elements as silencer SR 315/900 (16 Pa) and in the backdraft damper KOM 315 (22 Pa). Make also the calculation of the pressure loss in the tapping to the grilles. The total air resistance of 4 tappings makes 8 Pa.

**Pressure loss calculation at the duct bends**

The diagram enables calculation of the pressure loss in the tapping on the basis of bend angle, air duct diameter and air capacity.

**Example.** Calculate the pressure loss for 90° bend, Ø 250 mm and air capacity 500 m<sup>3</sup>/h. For that find the intersection point of the vertical line that shows the air capacity with the vertical line. Find the pressure loss on the vertical line on the left for 90° pipe bend which makes 2 Pa.

We consider PF ceiling air diffusers and calculate their resistance according to the diagram which makes 26 Pa.

Now let us sum up all the pressure losses for the straight air duct section, network elements, bends and grilles. The ought quantity is 186.3 Pa.

We have calculated the whole system and have come to the conclusion that we need the exhaust fan to remove 1570 m<sup>3</sup>/h during the system resistance 186.3 Pa. Considering all the required operating characteristics VENTS VKMS 315 fan suits our requests.

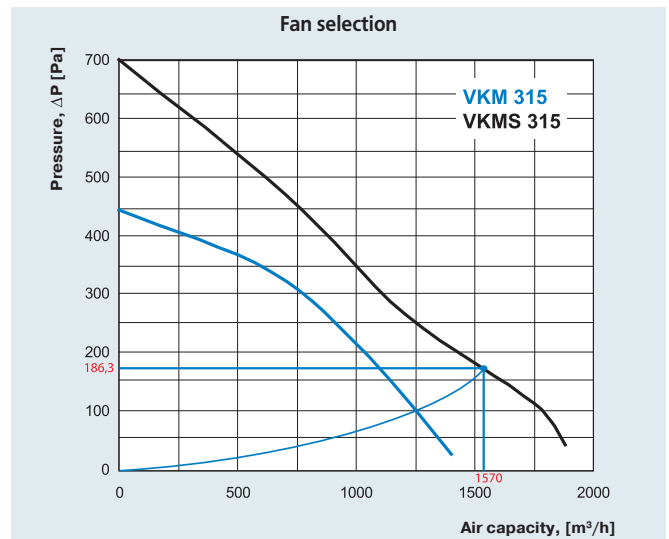
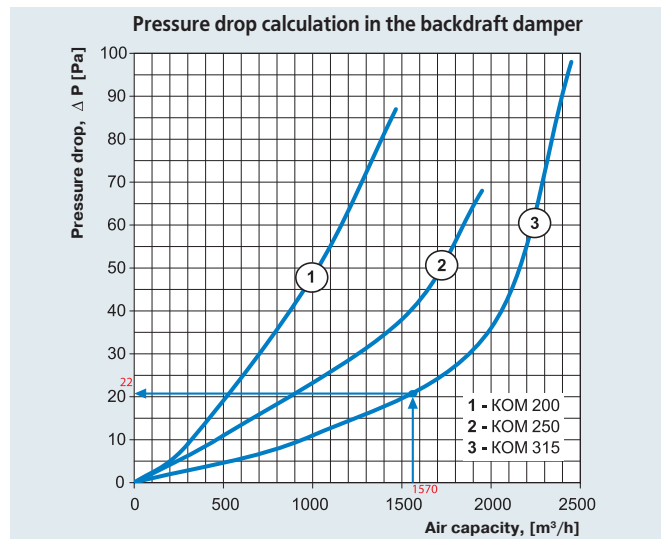
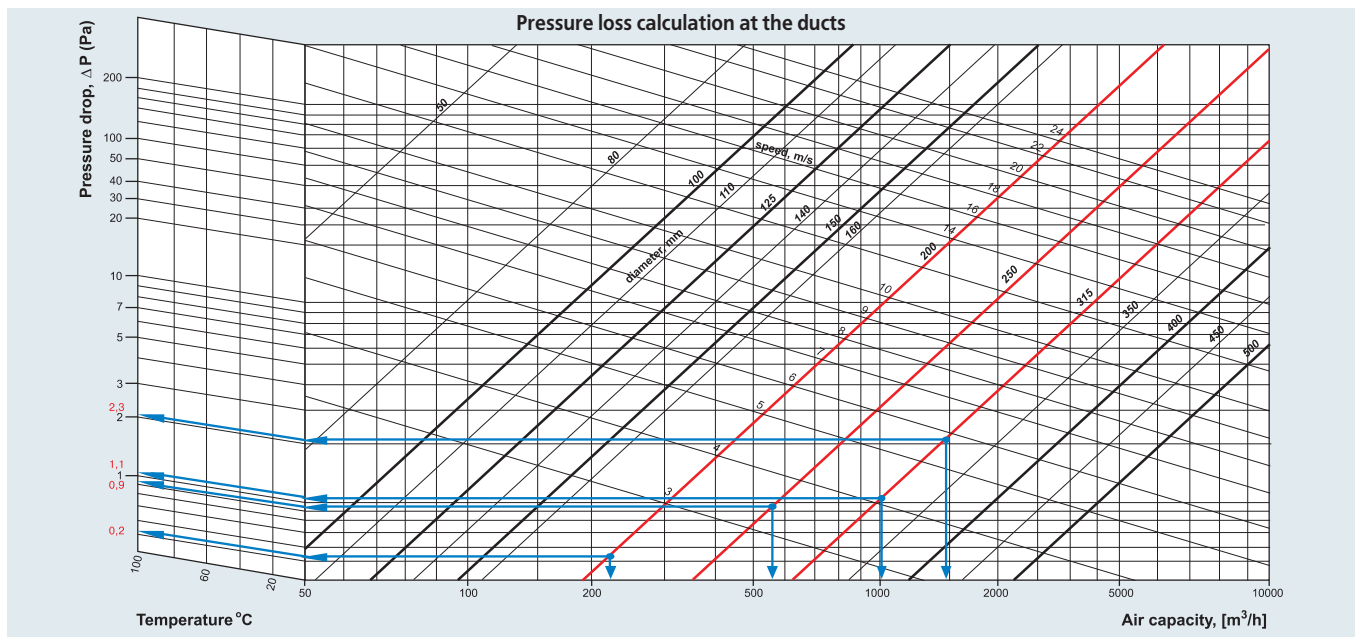



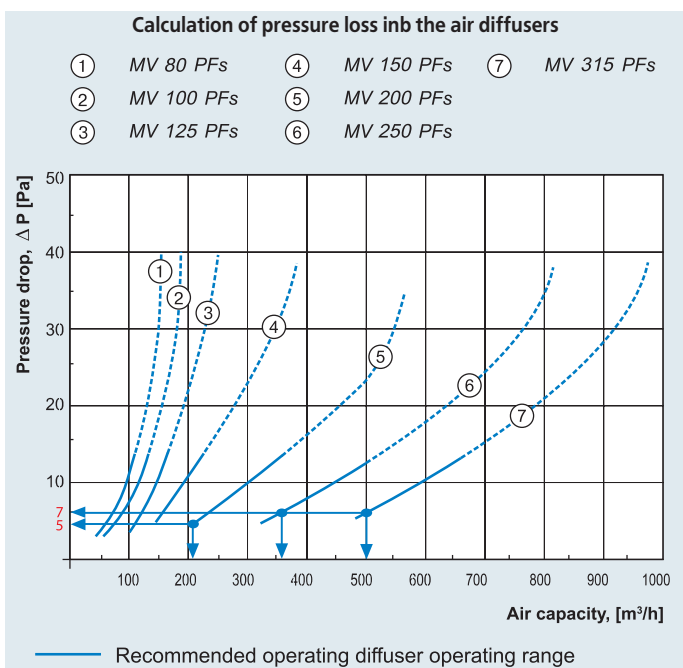
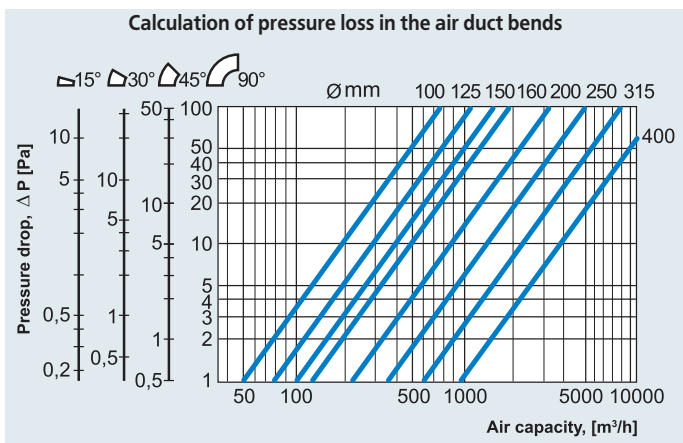
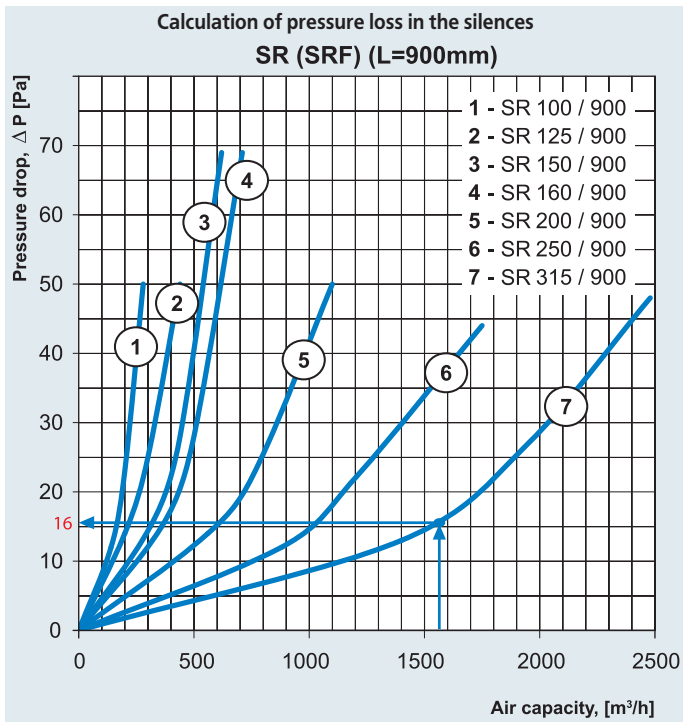

**Fan types:**

**Fans** are mechanical units designed for air transportation in the ducts, direct air supply or air exhaust from the premises. Air is moved due to pressure drop at the fan intake and exhaust.

**Axial-flow fan** has the form a cylindrical-cased wheel with the impeller fixed to a bushing at some angle to rotation plane. As the impeller blades rotate air is trapped between and is moved further axially. Air is not transferred in the radial direction. The axial fan blades are mostly set directly on the motor shaft.

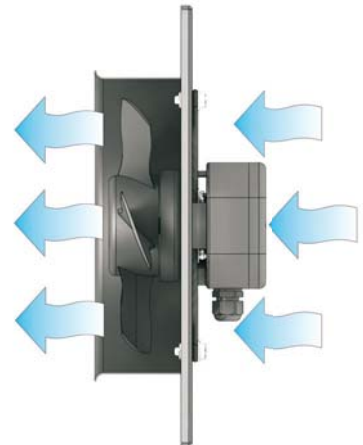

**Application:**

▶ air supply and exhaust through free entries or in one set with no more than 3 m air ducts placed horizontally with low aerodynamic resistance of the network.

**Mixed flow fans combining the features of centrifugal and axial fans** can transfer air in the motor axis direction. Such fans are widely applied in the ventilation systems with round air ducts.

Round duct fans are available in standard sizes ranging from 100 up to 450 mm with the capacity ranging from 250 to 5200 m<sup>3</sup>/h. The impellers with backward-curved blades are powered by the asynchronous external rotor motors. The ball bearings are applied for long service life. The fan casings are made of plastic, steel with polymeric coating or galvanized steel to ensure corrosion resistance and pleasant aesthetic look.

**Application:**

▶ air exhaust and supply in large ventilation systems with high air dynamic resistance.

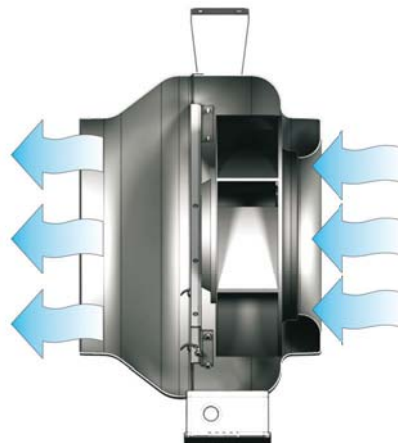

**Centrifugal fans** consist of two basic components - turbine and scroll casing. Impeller of centrifugal fan is a hollow cylinder with mounted blades inside, circumferentially fixed with disk plates. The hub for mounting the impeller on the shaft is located at the center of the strengthening ring.

During the impeller operation air is trapped between the blades and moves radially from the center compressed. Under centrifugal force air is transported to the scroll casing and then moved to the exhaust pipe. Centrifugal fans incorporate forward- or backward-curved blades. Use of centrifugal impellers with backward-curved blades allows up to 20% energy saving. Another important privilege of backward-curved blades is their high air overload capability. Centrifugal fans with forward-curved blades ensure the same air capacity and pressure characteristics



**Backward curved blades**

as the backward-curved blades do but they require smaller impeller diameter and lower speed. So they are able to attain the required result demanding less space and producing less noise.

**Application:**

▶ air exhaust and supply in ventilation systems with large-extensions ventilation systems and high air dynamic resistance.

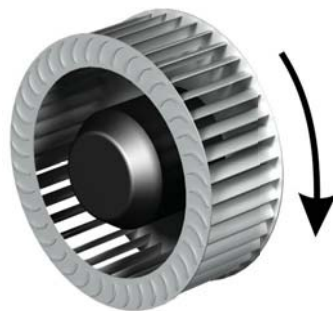

**Forward curved blades**

▶ **Fan speed control**

Speed control is effected by means of thyristor or transformer speed controllers.

**Thyristor speed control.**

Smooth speed controllers are designed for manual motor speed control and produces by this fans air flow capacity respectively. Speed controller operation is based on smooth voltage output by means of the thyristor.

Several motors can be controlled simultaneously if their total current does not exceed the maximum permissible value of the controller current.

Such controllers are featured with high control efficiency and accuracy. When operating in low-speed mode the fans can produce more noise. For that reason such fan is not recommended for low-noise application. Low-voltage motor application results in reducing bearings service life. The recommended control interval is 60-100% of the rated voltage.

**Transformer speed control.**

Transformer speed controller operation is based on five-staged autotransformer for control of motor power supply voltage. During the controller operation the frequency does not change.

Transformer controllers are designed for voltage-controlled motor speed control. One transformer can control several fans in case their total current does not exceed the controller rated current value.

During transformer speed controlling the motor does not produce more noise while operating in low-speed mode. However the motor bearings service life can be reduced as a result of continuous low-voltage operation mode (speed 1 or 2).

▶ **Fan motors**

**External rotor motors**

External rotor motor design is similar to asynchronous motor design but the motor rotor is located outside of the stator winding and the stator with the windings is located in the motor centre. Such original modification ensures the compact size of the unit. The motor shaft rotates on the ball bearings mounted inside the stator. The impeller is fixed on the rotor casing. Such design provides air cooling of the electric motor which allows using the fans in the wide temperature range. All the motors and impellers are statically and dynamically balanced at the manufacturing facility.



**EC-motor powered equipment**

EC motor is an electric motor driven by electronically commutated direct current controller that has no friction or wear parts such as commutator and brushes in standard direct current motors. This function is performed by maintenance-free EC-controller PCB. New electric motors are featured with high efficiency and the best control over the whole speed range. EC-motor electronic controller enables extra functions as speed control as a function of temperature sensor or pressure sensor reading or other parameters.

**EC-motor advantages:**

- ▶ efficient performance at any motor speed up to zero;
- ▶ lowered heat generation;
- ▶ fan overall dimensions can be reduced due to external rotor motor configuration;
- ▶ maximum motor speed does not depend on the mains power supply frequency and operation both at 50 and 60 Hz is possible;
- ▶ high efficiency at low speed;
- ▶ data exchange between PC and fan for setting and controlling the operating characteristics;
- ▶ centralized control of several fans integrated into a single system.

Custom designed software provides high accuracy control of the fans integrated into network.

The LED-display of the computer shows all the system parameters and the operation mode can be set individually for each fan in the network. Operating characteristics of a specific fan integrated into the network can be centrally corrected to match the ventilation system parameters. Such technology provides adjusting the ventilation system in compliance with the customer requirements.

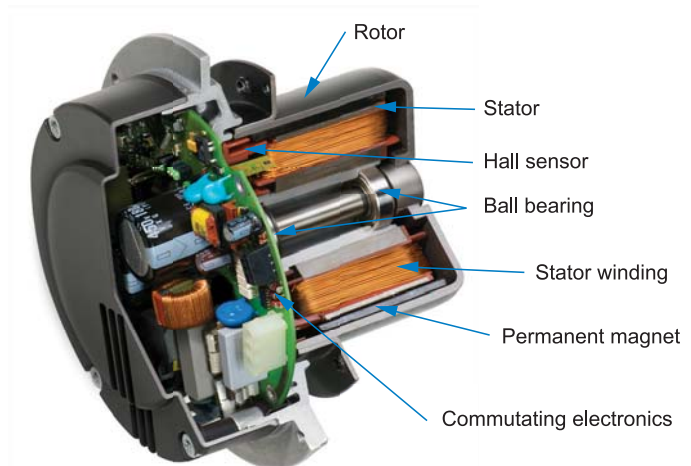

**▶ General mounting recommendations**

To reduce the airstream turbulence induced losses a straight air duct segment shall be laid at the fan inlet and outlet. The minimum straight segment length shall be at least 1 air duct diameter at inlet and 3 air duct diameters at outlet. These segments shall not incorporate filters or other similar equipment. For rectangular ducts the respective air duct diameter is calculated as follows:

$$D = \sqrt{\frac{4 \cdot H \cdot B}{\pi}}$$

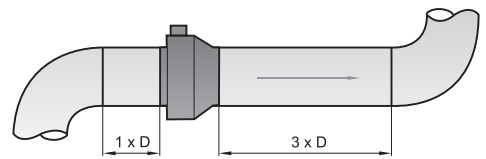

**D** = air duct diameter  
**H** = air duct height  
**W** = air duct width

**▶ Fan noise characteristics**

Noise characteristics of the equipment are shown in the tables indicating:  
 ▶ Sound-power level LWA in dBA i frequency bands to inlet, outlet and environment of the fan.

▶ The total sound power level dB(A) at 3 m distance.  
 The frequency band has eight wave groups. Each group has a definite medium frequency: 63 Hz, 125 Hz, 250 Hz, 500 Hz, 1000 Hz, 2 kHz, 4 kHz and 8 kHz. Any noise is distributed to definite frequency bands and the sound energy is dissipated to various frequency.

The sound produced by the operating fan is spread along the air duct, partially attenuates inside the unit and penetrates through the grilles inside the premise. Ventilation system design is based on acoustic calculation which is an integral part of any premise ventilation design. The calculation is aimed to define the octave-frequency band in the operating points and the required sound attenuation level by means of comparing this spectrum with the permissible values according to hygienic regulations. After selection of construction and acoustic means for sound attenuation the expected sound-pressure levels are tested to check the efficiency in the selected operating points.

dBa	Characteristics	Sound source
0	no noise	
5	almost not audible	
10		low leaves rustling
15		medium leaves rustling
20	hardly audible	human whisper (1 m distance)
25		human whisper (1 m distance)
30	quiet	whisper, wall clock ticking
35		standard sound level for residential premises from 23.00 till 07.00
40	quite audible	low speech
45		conventional speech
50		standard sound level for residential premises from 07.00 till 23.00
55	definitely audible	conventional conversation
60		conversation, typing
65	noisy	Norm for A office premises (EN)
70		office standard
75		loud conversation (1 m)
80		several loud conversations (1 m)
85		shout, laughter
90	very noisy	shouting, operating motorcycle with a silencer
95		loud shouting, operating motorcycle with a silencer
100		Loud shouts, freight car (7 m)
105	Extremely noisy	moving subway train (7 m)
110		Orchestra, subway car (abruptly), thunder
115		Maximum permissible sound pressure for headphones of a personal stereo (according to European norms)
120		inside the airplane (before 1980s)
125		helicopter
130	Almost unbearable	sandblaster (1 m)
135	Pain threshold	pneumatic hammer (1 m)
140		airplane at start

## ▶ What is IP?

During the equipment selection and installation location it is extremely important to ensure matching the protection rating to the equipment operating conditions. Any electrical appliance shall meet two protection requirements simultaneously, i.e. to ensure safety to the user and the maintenance staff and to protect the electrical components located inside the appliance against environmental impact, i.e. Ingress Protection (IP). IP rating refers to dust-proof and moisture protection of the equipment and its electrical safety.

Information regarding protection rating marked IP and two digits indicating protection degree is shown in the documentation and on casing of the equipment, i.e. IP20 or IP65. The first digit of IP designation shows the degree of protection against access to hazardous objects. Protection characteristics defined by the first digit is shown in the table 1. The second digit shows the degree of protection against water ingress and its characteristics are shown in the table 2.







**Table 1**

First digit	Protection characteristics	Description
x	Protection rating is not defined	Oped construction, no dust protection and protection against contact with current-carrying parts.
1	Large-scale objects protection	Protection from OBJECTS EQUAL TO OR GREATER THAN 50 mm and hand accidental touch to current-carrying parts.
2	Medium-size objects protection	Protection from OBJECTS EQUAL TO OR GREATER THAN 12 mm. and fingers touch to current-carrying parts.
3	Small-size objects protection	Protection from OBJECTS EQUAL TO OR GREATER THAN 2,5 mm and entry by tools, wires or fingers.
4	Sand protection	Protection from OBJECTS EQUAL TO OR GREATER THAN 1 mm and entry by tools, wires or fingers.
5	Dust protection	Significant dust quantity can be accumulated inside the casing which does not disturb the rated operation. Full protection against touch to current-carrying parts.
6	Dust-tight protection	No dust penetration inside the configuration

**Table 2**

Second digit	Protection characteristics	Description
x	Protection rating is not defined	Open construction with no protection against water
1	Protection against VERTICALLY DRIPPING WATER	Water drops dripping vertically do not damage equipment
2	Protection from vertically dripping water (15° tilted)	Water drops falling vertically at 15° do not damage equipment
3	Protection from sprayed water	Water falling as a spray at any angle up to 60° from the vertical shall have no harmful effect.
4	Protection from splashed water	Water splashing against the enclosure from any direction shall have no harmful effects for the equipment in the casing.
5	Protection from jetting water	Water projected by a nozzle against enclosure from any direction shall have no harmful effects for the equipment in the casing.
6	Protection from powerfully jetting water	Water projected in powerful jets against the enclosure from any direction shall have no harmful effects for the equipment in the casing.
7	Protection against temporary immersion	Ingress of water in harmful quantity shall not be possible when the equipment is immersed in water.
8	Protection against complete, continuous submersion in water	The equipment is suitable for continuous immersion in water under conditions which shall be specified by the manufacturer.

## Certification

	CE-marked equipment means that the goods are produced in compliance with the quality and safety standards provided by EU regulations for the current item (marked by the manufacturer).		Mark of conformity to the Ukrainian Quality Standards and electrical safety issued by Ukrtest.
	Mark of conformity to the European Quality Standards and electrical safety issued by Association for Technical Inspection (Technischer Überwachungsverein, Germany).		Mark of conformity of the goods subject to obligatory certification in DSTR system as well as technical norms and standards acting at Russian Federation.
	Mark of conformity to the Polish Quality Standards and electrical safety issued by PCBC (Polish center for testing and certification).		Insulation class: double insulation.
	Mark of conformity to the Slovak Quality Standards and electrical safety issued by EVPU (Slovakia).	<b>IP 34</b>	Appliance protection rating (refer to tables 1, 2).



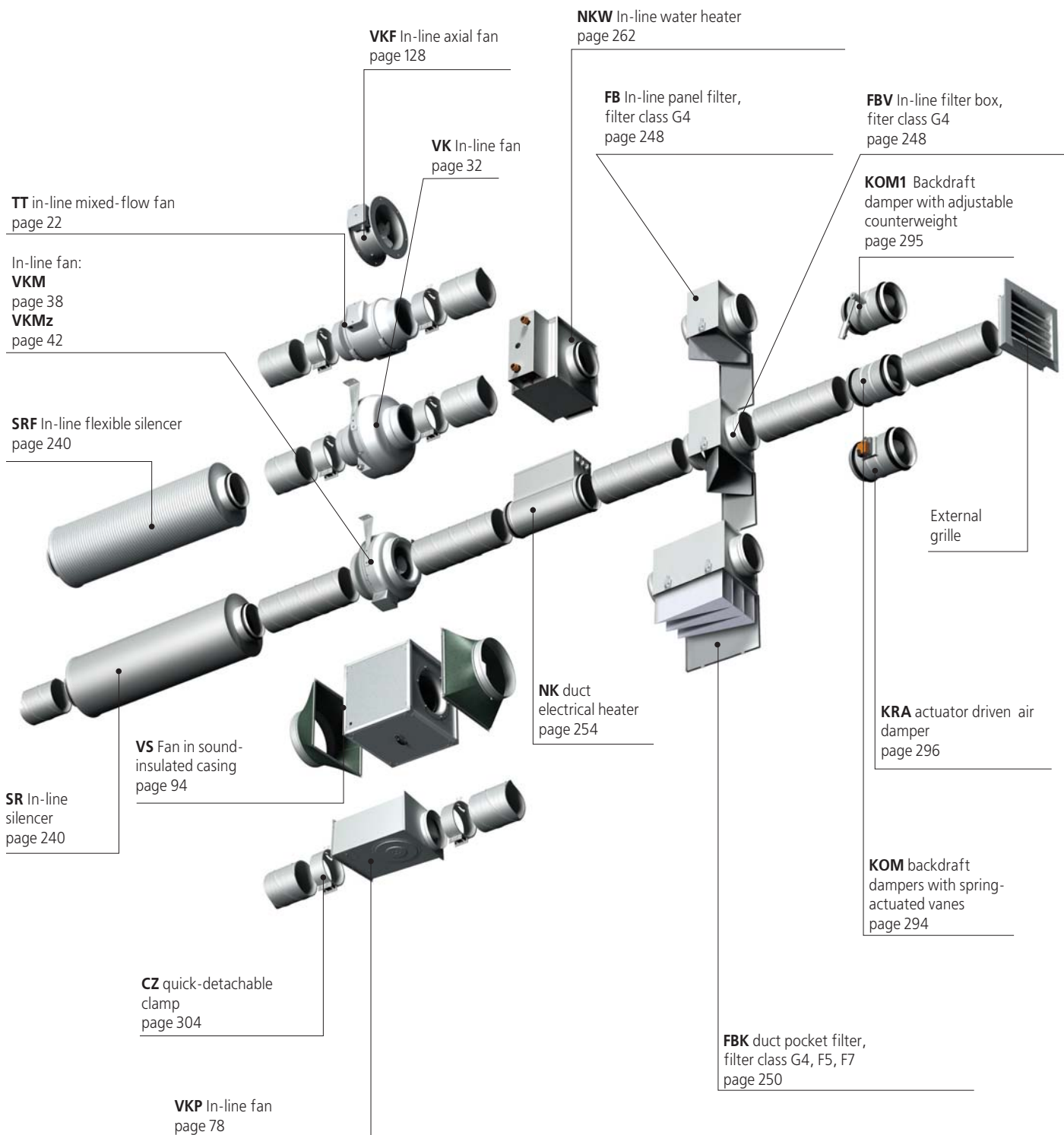

## SELECTION TABLE FOR ROUND ITEMS

	d=100 mm	d=125 mm	d=150 mm	d=160 mm	d=200 mm	d=250 mm	d=315 mm
<b>Fans</b>	TT 100	TT 125	TT 150	TT 160	TT 200	TT 250	TT 315
		TT 125 S					
	VK 100 Q	VK 125 Q			VK 200	VK 250 Q	VK 315
	VK 100	VK 125	VK 150	VK 160	VKS 200	VK 250	VKS 315
	VKM 100 Q	VKM 125 Q			VKM 200	VKM 250 Q	VKM 315
	VKM 100	VKM 125	VKM 150	VKM 160	VKMS 200	VKM 250	VKMS 315
	VKMz 100 Q	VKMz 125 Q			VKMz 200 Q	VKMz 250 Q	VKMz 315 Q
	VKMz 100	VKMz 125	VKMz 150	VKMz 160	VKMz 200	VKMz 250	VKMz 315
	VC 100 Q	VC 125 Q			VC 200	VC 250 Q	VC 315
	VC 100	VC 125	VC 150	VC 160	VCS 200	VC 250	VCS 315
	VCN 100	VCN 125	VCN 150	VCN 160	VCN 200		
	VKP 100 mini						
	VKP 100	VKP 125	VKP 150	VKP 160	KSB 200	KSB 250	KSB 315
	KSB 100	KSB 125	KSB 150	KSB 160	KSB 200 S		
					VKF 2E 200	VKF 2E 250	VKF 2E 300
						VKF 4E 250	VKF 4E 300
<b>Filters</b>	FB 100	FB 125	FB 150	FB 160	FB 200	FB 250	FB 315
	FBV 100	FBV 125	FBV 150	FBV 160	FBV 200	FBV 250	FBV 315
	FBK 100-4	FBK 125-4	FBK 150-4	FBK 160-4	FBK 200-4	FBK 250-4	FBK 315-4
	FBK 100-5	FBK 125-5	FBK 150-5	FBK 160-5	FBK 200-5	FBK 250-5	FBK 315-5
	FBK 100-7	FBK 125-7	FBK 150-7	FBK 160-7	FBK 200-7	FBK 250-7	FBK 315-7
<b>Heaters</b>							
electrical	NK 100 0,6-1	NK 125 0,6-1	NK 150 1,2-1	NK 160 1,2-1	NK 200 1,2-1	NK 250 1,2-1	NK 315 1,2-1
	NK 100 0,8-1	NK 125 0,8-1	NK 150 2,4-1	NK 160 2,4-1	NK 200 2,4-1	NK 250 2,4-1	NK 315 2,4-1
	NK 100 1,2-1	NK 125 1,2-1	NK 150 3,4-1	NK 160 3,4-1	NK 200 3,4-1	NK 250 3,0-1	NK 315 3,6-3
	NK 100 1,6-1	NK 125 1,6-1	NK 150 3,6-3	NK 160 3,6-3	NK 200 3,6-3	NK 250 3,6-3	NK 315 6,0-3
	NK 100-1,8-1	NK 125 2,4-1	NK 150 5,1-3	NK 160 5,1-3	NK 200 5,1-3	NK 250 6,0-3	NK 315 9,0-3
			NK 150 6,0-3	NK 160 6,0-3	NK 200 6,0-3	NK 250 9,0-3	
water heating coils	NKW 100-2	NKW 125-2	NKW 150-2	NKW 160-2	NKW 200-2	NKW 250-2	NKW 315-2
	NKW 100-4	NKW 125-4	NKW 150-4	NKW 160-4	NKW 200-4	NKW 250-4	NKW 315-4
<b>Silencers</b>	SR 100	SR 125	SR 150	SR 160	SR 200	SR 250	SR 315
	SRF 100	SRF 125	SRF 150	SRF 160	SRF 200	SRF 250	SRF 315
<b>Dampers, shutters</b>	KOM 100	KOM 125	KOM 150	KOM 160	KOM 200	KOM 250	KOM 315
	KOM1 100	KOM1 125	KOM1 150	KOM1 160	KOM1 200	KOM1 250	KOM1 315
	KR 100	KR 125	KR 150	KR 160	KR 200	KR 250	KR 315
	KRA 100	KRA 125	KRA 150	KRA 160	KRA 200	KRA 250	KRA 315
<b>Flexible connectors</b>	VVG 100	VVG 125	VVG 150	VVG 160	VVG 200	VVG 250	VVG 315
<b>Clamps</b>	CZK 100	CZK 125	CZK 150	CZK 160	CZK 200	CZK 250	CZK 315
	CZ 100	CZ 125	CZ 150	CZ 160	CZ 200	CZ 250	CZ 315
	C 100	C 125	C 150	C 160	C 200	C 250	C 315
	CB 100	CB 125	CB 150	CB 160	CB 200	CB 250	CB 315
<b>Speed controllers</b>							
thyristor speed controllers	RS series	RS series	RS series	RS series	RS series	RS series	RS series
transformer speed controllers	RSA series	RSA series	RSA series	RSA series	RSA series	RSA series	RSA series



# ROUND DUCT FANS

## ▶ VENTS TT series



- ▶ In-line mixed fans in the plastic casing with the air capacity up to 2350 m<sup>3</sup>/h. Designed for supply and exhaust ventilation.

## ▶ VENTS VK series



- ▶ In-line centrifugal fans in the plastic casing with the air capacity up to 1700 m<sup>3</sup>/h. Designed for supply and exhaust ventilation systems.

## ▶ VENTS VKM and VKMz series



- ▶ In-line centrifugal fans in the steel casing with polymeric coating (air capacity up to 5260 m<sup>3</sup>/h) or in casing made of galvanized steel (air capacity up to 1540 m<sup>3</sup>/h). Designed for supply and exhaust ventilation systems.

## ▶ VENTS VC series



- ▶ In-line centrifugal fans with the air capacity up to 1880 m<sup>3</sup>/h. Designed for supply and exhaust ventilation systems.

## ▶ VENTS VCN series

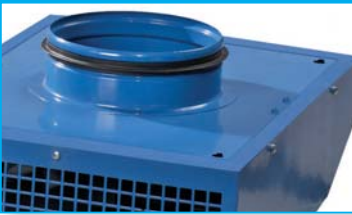

- ▶ In-line centrifugal fan in the steel casing with the air capacity up to 710 m<sup>3</sup>/h, for outdoor wall mounting. Designed for exhaust ventilation system.

## ▶ VENTS VKP and VKP mini series



- ▶ Compact centrifugal VKP fans for round ducts in steel casing with the air capacity up to 553 m<sup>3</sup>/h.
- ▶ Compact centrifugal VKP mini fans for round ducts in steel casing with the air capacity up to 176 m<sup>3</sup>/h supporting constant air flow at alternating pressure in the system. Designed for supply and exhaust ventilation systems.



**In-line mixed-flow fan  
VENTS TT**

Air capacity – up to 2350 m<sup>3</sup>/h

page  
22



**VENTS VK  
In-line centrifugal fan**

Air capacity – up to 1700 m<sup>3</sup>/h

page  
32



**VENTS VKM  
In-line centrifugal fan**

Air capacity – up to 5260 m<sup>3</sup>/h

page  
38



**VENTS VKMz  
In-line centrifugal fan**

Air capacity – up to 1540 m<sup>3</sup>/h

page  
42



**VENTS VC  
In-line centrifugal fan**

Air capacity – up to 1880 m<sup>3</sup>/h

page  
46



**VENTS VCN  
Exhaust centrifugal fan**

Air capacity – up to 710 m<sup>3</sup>/h

page  
50



**VENTS VKP  
In-line centrifugal fan**

Air capacity – up to 553 m<sup>3</sup>/h

page  
54



**VENTS VKP mini  
In-line centrifugal fan**

Air capacity – up to 176 m<sup>3</sup>/h

page  
56



Series  
**VENTS TT**



In-line mixed-flow fans in plastic casing with the air capacity up to **2350 m<sup>3</sup>/h.**

■ **Applications**

VENTS TT series full-featured fans combine manifold possibilities and high features of axial and centrifugal fans and applied for supply and exhaust ventilation systems that require high pressure, powerful airflow and low noise level and compatible with 100, 125, 150, 160, 200, 250, 315 mm round ducts. Fans of TT series are the best solution for air exhaust systems of premises with high humidity such as bathrooms or kitchens as well as for ventilation of flats, cottages, shops, cafés, cinemas etc. The wide model range and many options allows selecting the best suitable fan.

■ **Design**

The casing is made of high-quality durable ABS plastic (TT 100-200) or fire resistant polypropylene (TT 250-315). Motor with impeller and terminal box are fixed on the casing by means of special clamps with latches, designed in such a way as to ensure easy dismantling without any special skills or tools. Such design ensures easy service and maintenance access.

All the models can be fitted with adjustable timer with turn-off delay from 2 to 30 minutes (TT...T). Power cord with plug can be provided for easy connection and operation (TT...R).

■ **Motor**

One-phase motor with ball bearings has two speeds. Some standard sizes have motors with more powerful features (TT...S). The motors are equipped with built-in overheating protection with automatic restart. Motor protection rating IP X4.

■ **Speed control**

The two speed motor is controlled by means of the external speed control switch. For smooth speed control use symistor or autotransformer controller connected to the terminal for motor maximum speed.

■ **Mounting**

The fan can be mounted in any place of duct system and at any angle, vertically or horizontally. Several fans can be mounted in parallel to increase the air capacity or in series to increase the operating pressure. The casing is fitted with a mounting plate for wall mounting. Installation with special support bracket PTT 100...315 (not included in the equipment list) is also possible.

The mounting box can be installed in any position for easy installation and connection.



■ **TT Fan with TSC electronic speed control module with temperature sensor**

TT...U model fan with electronic temperature and speed module is the perfect solution for ventilation of greenhouses or any other premises requiring permanent temperature control. The fan is equipped with built-in TSC electronic speed control module with temperature sensor providing fan speed automatic control as a function of the air temperature.

The TSC front panel is equipped with two control knobs for presetting the minimum fan speed and the maximum indoor temperature level. The module is fitted with indoor temperature sensor located either remote (4 m long and protected against mechanical damages) or mounted inside the casing.

The LED indicator for thermostat switching on is placed at the front panel of the fan.

**Designation key:**

Fan series	Duct connection diameter	Options
<b>VENTS TT</b>	100; 125; 150; 160; 200; 250; 315	<p><b>S</b> – high-powered motor;  <b>T</b> – timer;  <b>U</b> – speed controller module with the built in temperature sensor;  <b>Un</b> – speed controller module with the external temperature sensor;  <b>U1</b> – speed controller with the built in timer and temperature sensor;  <b>U1n</b> – speed controller with the built in timer and external temperature sensor;  <b>V</b> – built-in three position switch (OFF-Min speed-Max speed);  <b>RV</b> – ON-OFF switch and power cord with C14 plug.</p>

**Accessories**



page 240    page 248    page 250    page 254    page 262    page 294    page 296    page 305    page 320    page 322    page 323

**■ TT operation pattern with electronic temperature and speed module**

Set the required air temperature with thermostat controller knob (thermostat operating threshold). Set the required rotation speed (air flow) with controller knob. As the air temperature rises and the thermostat operating threshold is exceeded, the motor switches automatically to the maximum rotation speed (maximum air flow). As the air temperature drops below the thermostat operating threshold the motor switches automatically to the preset rotation speed.

The switching delay disables frequent motor switching if the set ambient temperature is equal to the threshold temperature.

Two patterns of delay are applied for various cases:

1. Temperature sensor delay (TT...U): as the temperature rises at least by 2°C above the set threshold for thermostat switching, the motor switches to the increased rotation speed. The motor switches to the preset (low) speed as the temperature drops below the set threshold for thermostat switching. This pattern can be applied to keep air temperature to within 2°C. In this case

the fan switches are rare.

2. Timer delay (TT...U1): the motor sets to higher speed 5 min after the temperature exceeds the set threshold. The motor switches to the preset (low) speed 5 min. after the temperature drops below the set threshold.

This pattern can be used to keep the air temperature at a precise level. In this case the fan switches more frequently than in the pattern of temperature sensor delay, but the intervals do not exceed 5 minutes.

**■ Example for timer delay switches:**

Initial conditions:

- set rotation speed = 60% of maximum speed
- set operating threshold = 25°C
- air temperature in the duct = 20°C

motor operates with the motor speed =60%

- temperature in the duct rises

motor operates with the rotation speed =60%

- temperature in the duct reaches 27°C

motor switches to the rotation speed =100%

- temperature in the duct goes down motor operates with the rotation speed =100%

- temperature in the duct reaches 25°C

motor switches to the preset rotation speed =60%

**■ Example for timer delay switches:**

Initial conditions:

- set rotation speed = 60% of maximum speed
- set operating threshold =25°C
- air temperature in the duct =20°C

motor operates with the rotation speed =60%

- temperature in the duct rises, reaches 25°C and keeps rising

the motor switches to the rotation speed =100%, at the same moment the 5 minutes timer activates

- temperature in the duct goes down, motor operates with the rotation speed =100%

- temperature in the duct reaches 25°C and keeps going down

after the timer stops, the motor switches to the preset rated speed (=60%). After the speed switch the timer switches again for 5 minutes on.

- temperature in the duct rises, reaches 25°C and keeps rising

after the timer stops, the motor switches to the maximum speed (=100%). After the speed switch the timer switches again for 5 minutes on.

Thus, in timer delay pattern the delay timer activates every time the fan speed changes.

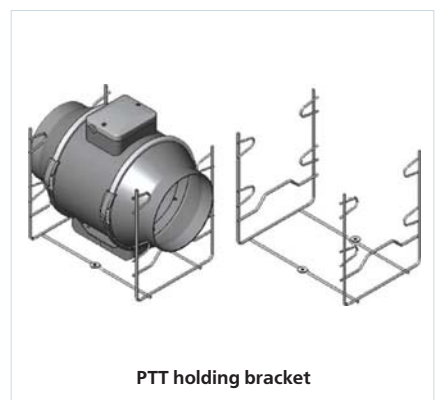
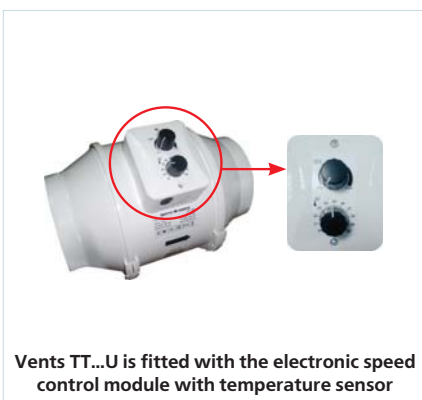

# FANS FOR ROUND DUCTS

## Technical data:

	TT 100		TT 125		TT 125 S		TT 150	
Speed	min.	max.	min.	max.	min.	max.	min.	max.
Voltage [V / 50 Hz]	1~ 230		1~ 230		1~ 230		1~ 230	
Power [W]	21	33	23	37	28	54	30	60
Current [A]	0,12	0,2	0,19	0,26	0,1	0,16	0,17	0,27
Maximum air flow [m³/h]	145	187	220	280	285	345	467	552
RPM [min <sup>-1</sup> ]	2450	2500	1960	2500	1875	2500	1670	2450
Noise level at 3 m [dBA]	28	35	29	36	31	42	33	44
Maximum operating temperature [°C]	60		60		60		60	
Protection rating	IP X4		IP X4		IP X4		IP X4	

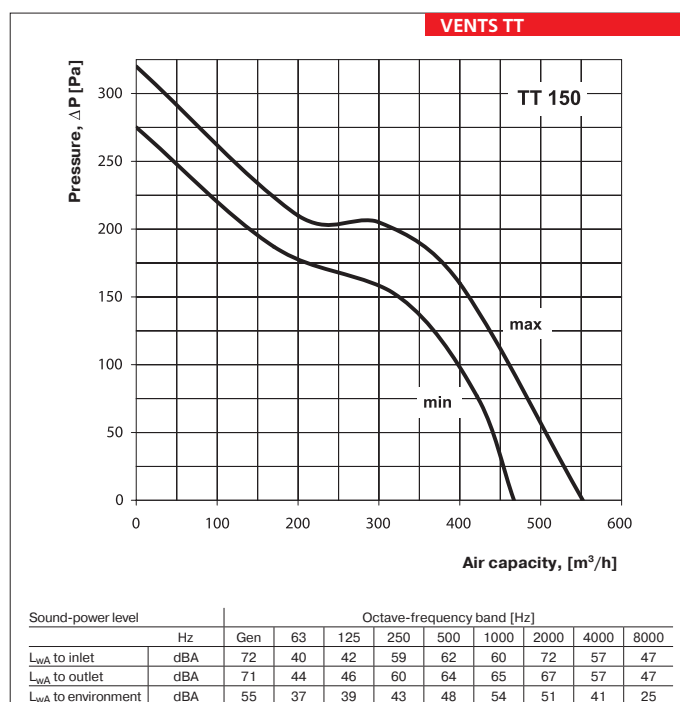
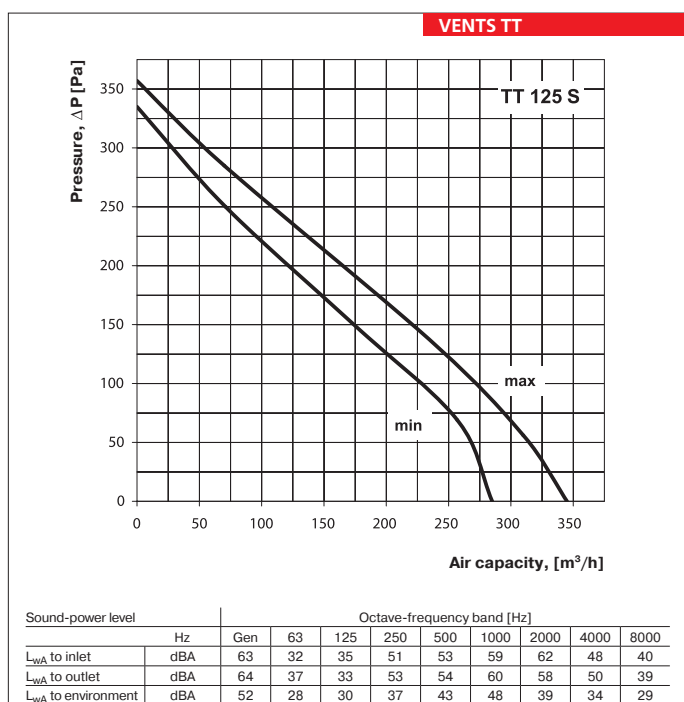
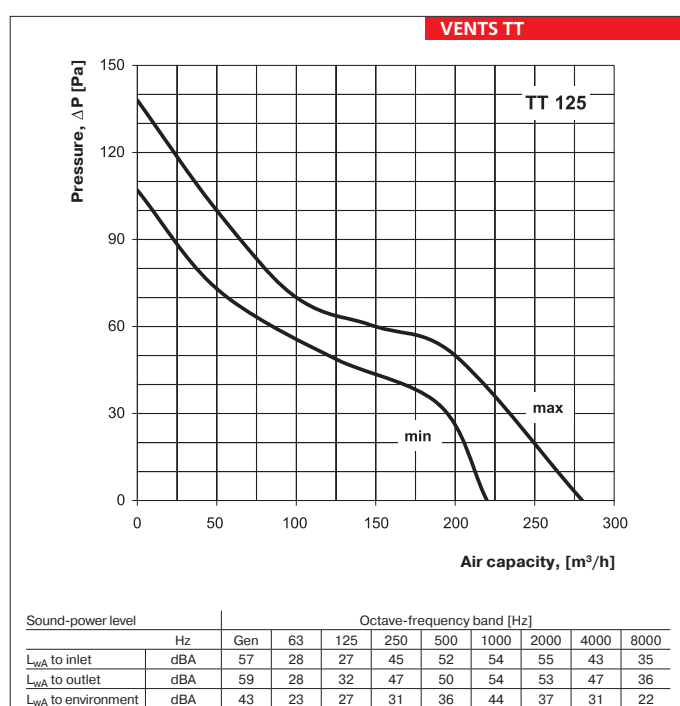
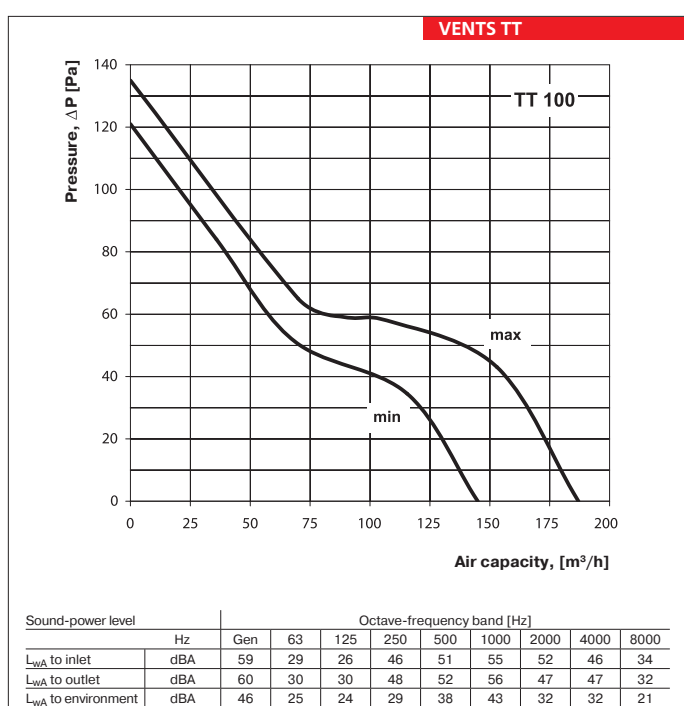

**Technical data:**

	TT 160		TT 200		TT 250		TT 315	
Speed	min.	max.	min.	max.	min.	max.	min.	max.
Voltage [V / 50 Hz]	1~ 230		1~ 230		1~ 230		1~ 230	
Power [W]	30	60	90	125	125	177	225	330
Current [A]	0,17	0,27	0,4	0,55	0,54	0,79	0,98	1,43
Maximum air flow [m³/h]	467	552	830	1040	1110	1400	1760	2350
RPM [min <sup>-1</sup> ]	1670	2450	2045	2510	1955	2440	1980	2660
Noise level at 3 m [dBA]	33	44	45	52	47	55	49	58
Maximum operating temperature [°C]	60		60		60		60	
Protection rating	IP X4		IP X4		IP X4		IP X4	

FAN SERIES VENTS TT

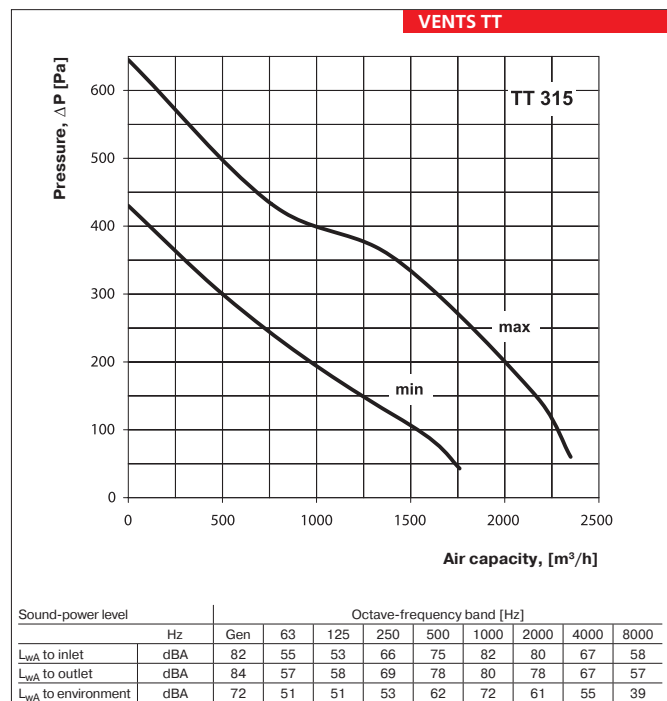
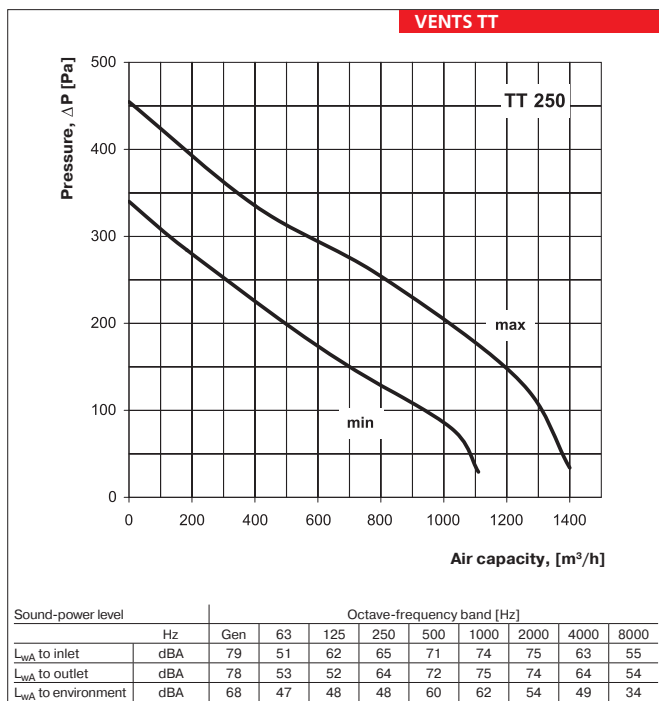
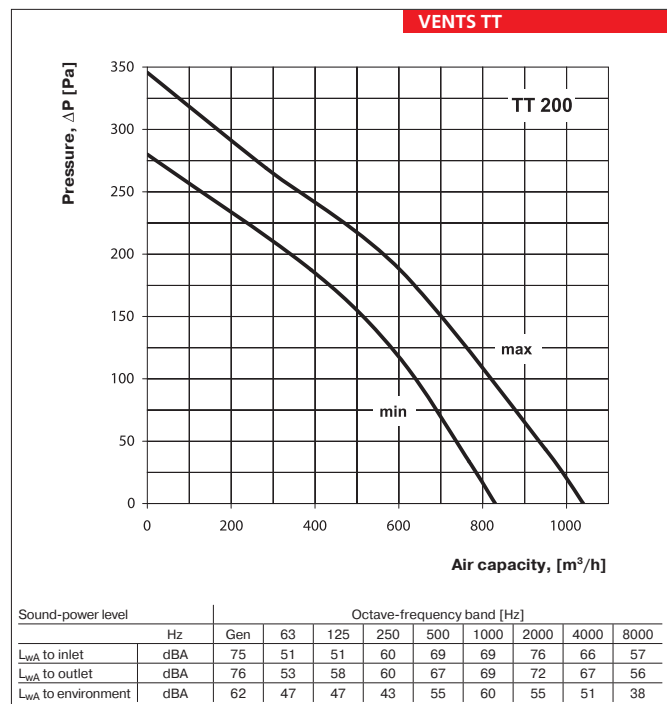
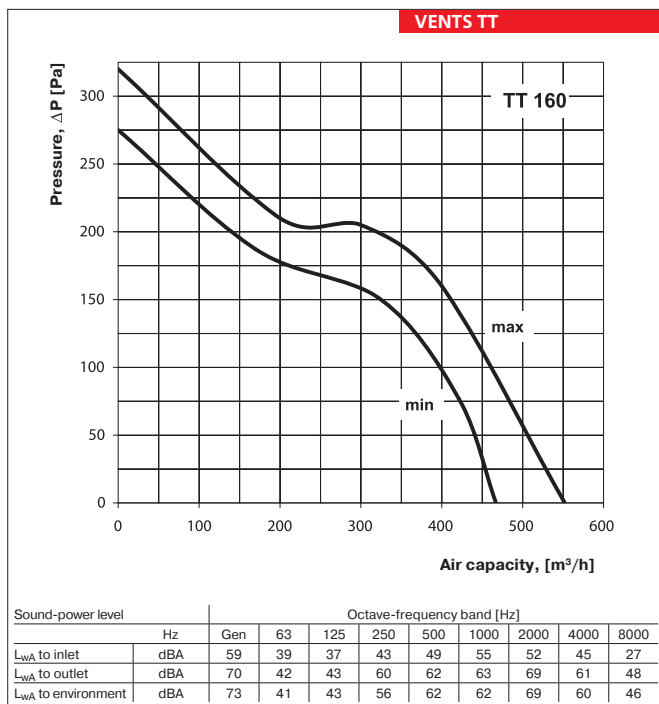



# FANS FOR ROUND DUCTS

## Technical data:

	TT 100 in series		TT 125 in series		TT 125 S in series		TT 150 in series	
Speed	min.	max.	min.	max.	min.	max.	min.	max.
Voltage [V / 50 Hz]	1~ 230		1~ 230		1~ 230		1~ 230	
Power [W]	42	66	46	74	56	108	60	120
Current [A]	0,24	0,40	0,38	0,52	0,20	0,32	0,34	0,54
Maximum air flow [m <sup>3</sup> /h]	145	187	220	280	285	345	467	552
RPM [min <sup>-1</sup> ]	2450	2500	1960	2500	1875	2500	1670	2450
Noise level at 3 m [dBA]	32	40	34	41	36	46	39	49
Maximum operating temperature [°C]	60		60		60		60	
Protection rating	IP X4		IP X4		IP X4		IP X4	

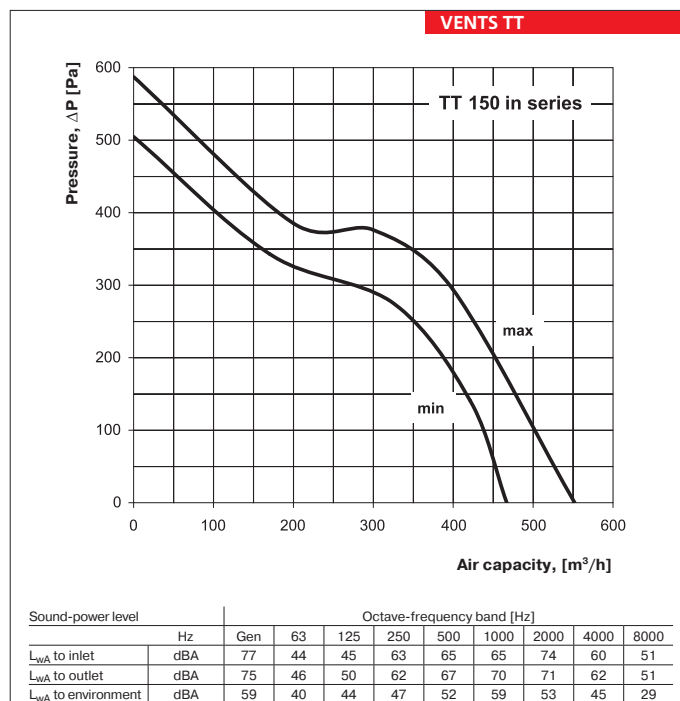
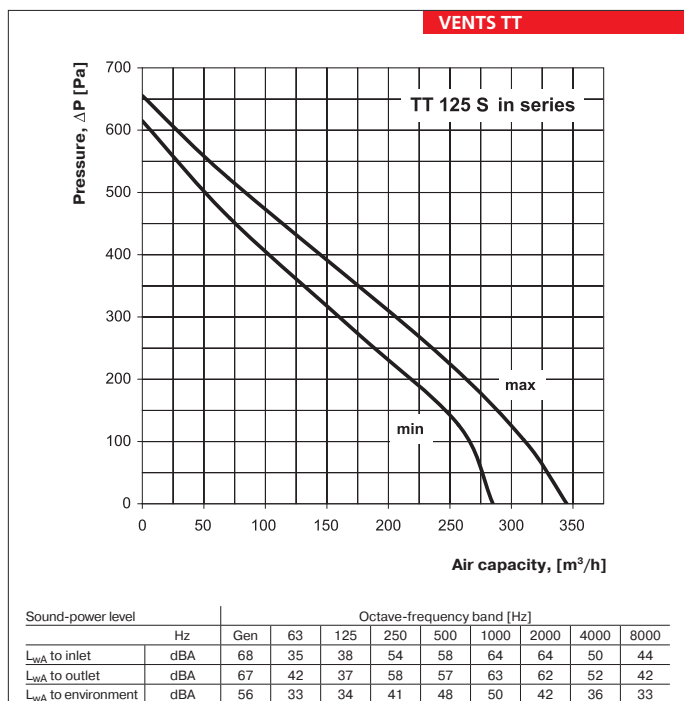
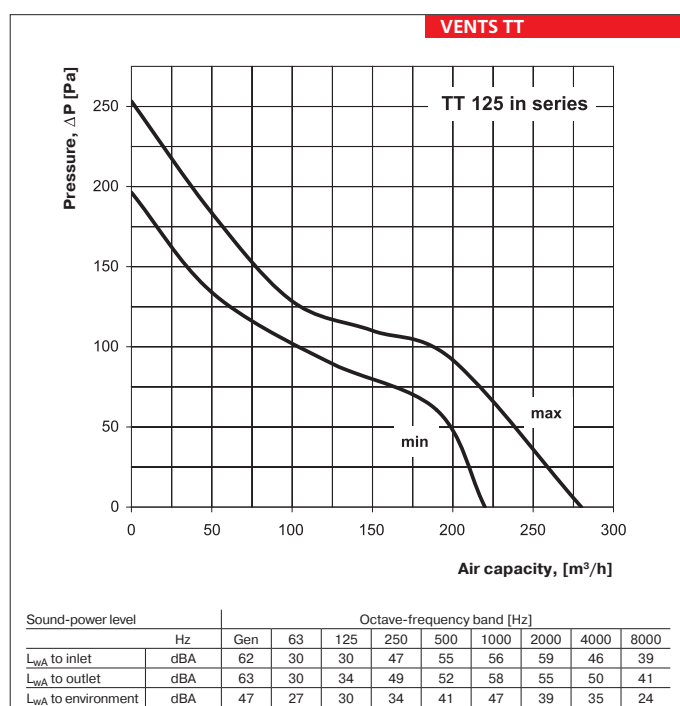
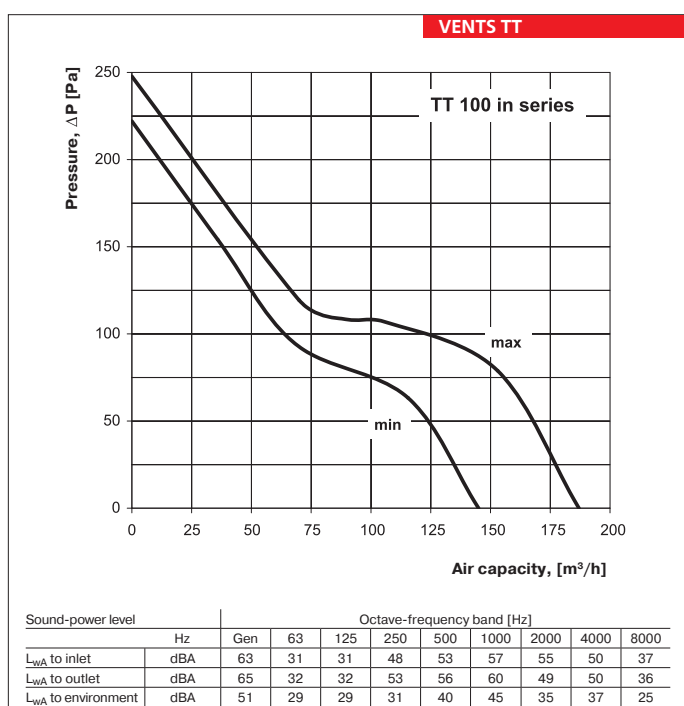

**Technical data:**

	TT 160 in series		TT 200 in series		TT 250 in series		TT 315 in series	
Speed	min.	max.	min.	max.	min.	max.	min.	max.
Voltage [V / 50 Hz]	1~ 230		1~ 230		1~ 230		1~ 230	
Power [W]	60	120	180	250	250	354	450	660
Current [A]	0,34	0,54	0,80	1,10	1,08	1,58	1,96	2,86
Maximum air flow [m³/h]	467	552	830	1040	1110	1400	1760	2350
RPM [min <sup>-1</sup> ]	1670	2450	2045	2510	1955	2440	1980	2660
Noise level at 3 m [dBA]	39	49	51	57	54	61	55	65
Maximum operating temperature [°C]	60		60		60		60	
Protection rating	IP X4		IP X4		IP X4		IP X4	

FAN SERIES VENTS TT

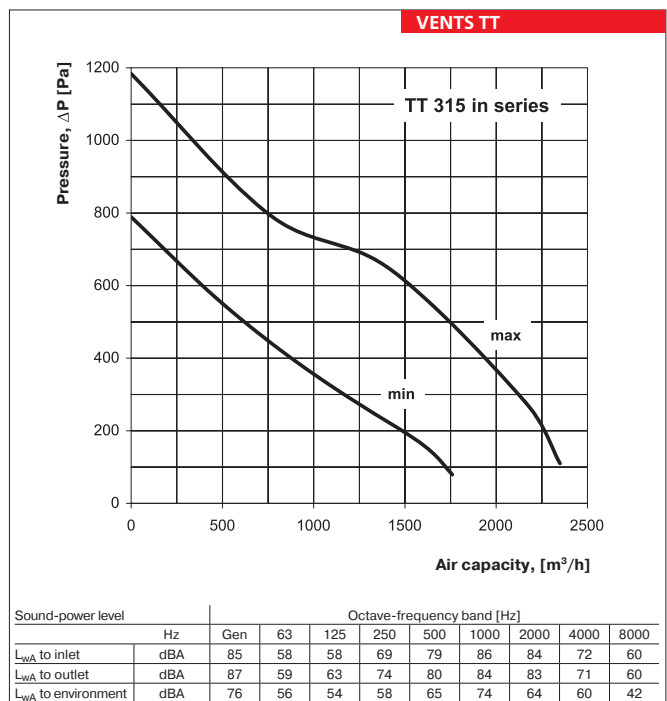
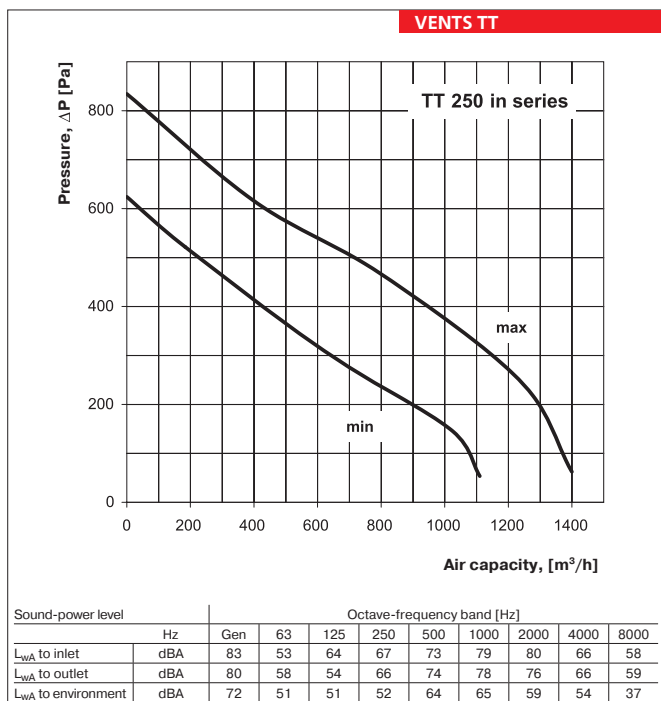
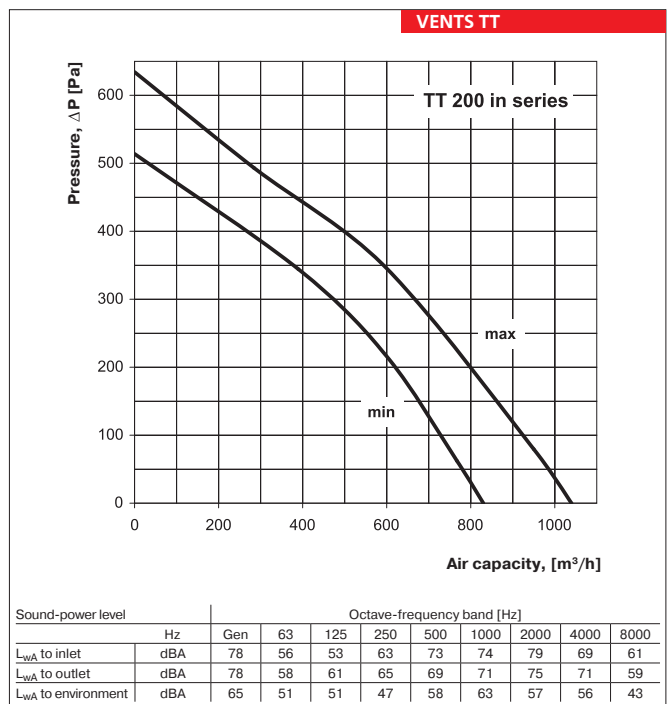
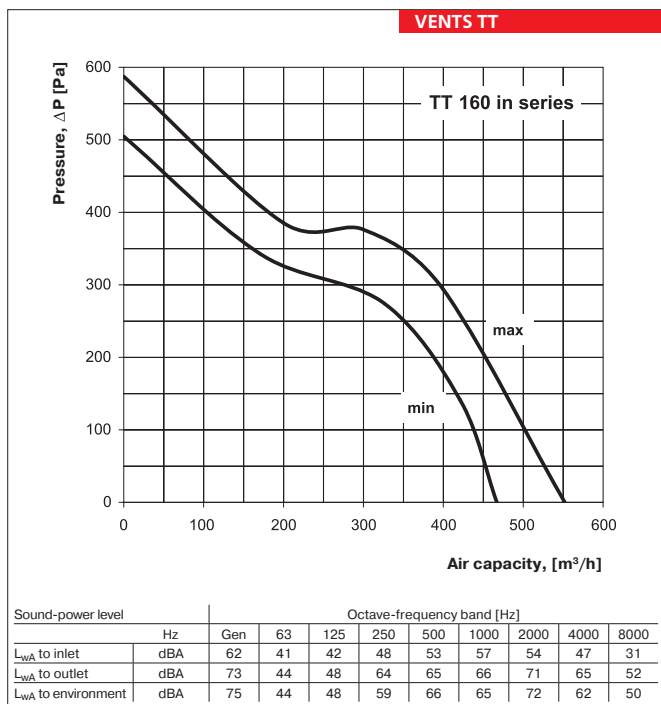

# FANS FOR ROUND DUCTS

## Technical data:

	TT 100 in parallel		TT 125 in parallel		TT 125 S in parallel		TT 150 in parallel	
Speed	min.	max.	min.	max.	min.	max.	min.	max.
Voltage [V / 50 Hz]	1~ 230		1~ 230		1~ 230		1~ 230	
Power [W]	42	66	46	74	56	108	60	120
Current [A]	0,24	0,40	0,38	0,52	0,20	0,32	0,34	0,54
Maximum air flow [m <sup>3</sup> /h]	290	374	440	560	570	690	934	1104
RPM [min <sup>-1</sup> ]	2450	2500	1960	2500	1875	2500	1670	2450
Noise level at 3 m [dBA]	32	40	34	41	36	46	39	49
Maximum operating temperature [°C]	60		60		60		60	
Protection rating	IP X4		IP X4		IP X4		IP X4	

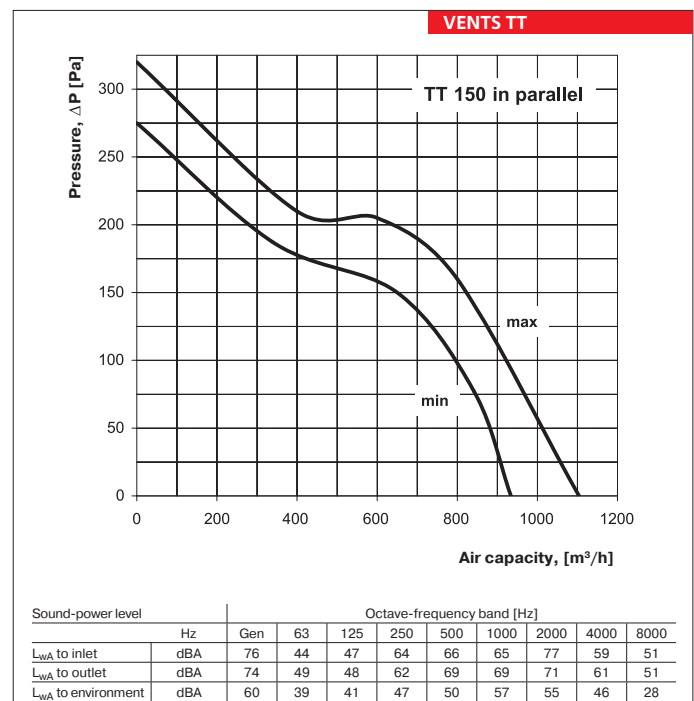
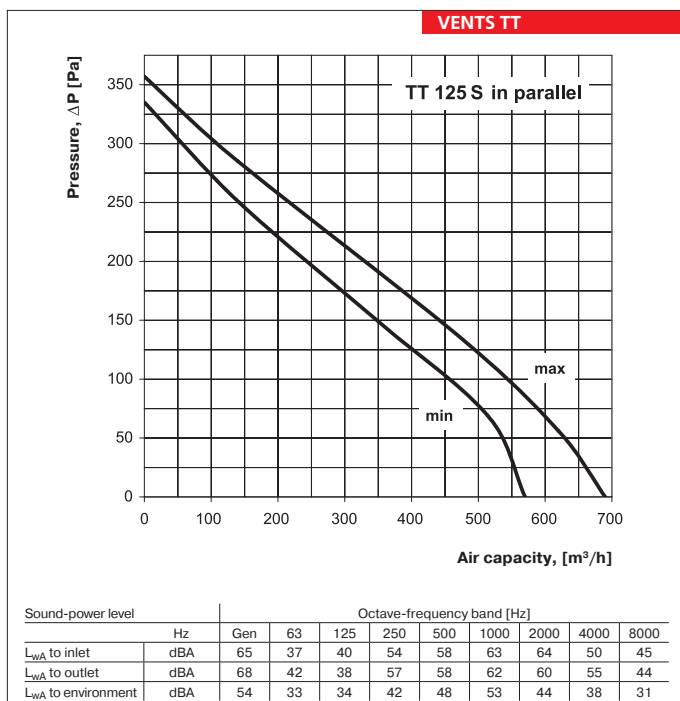
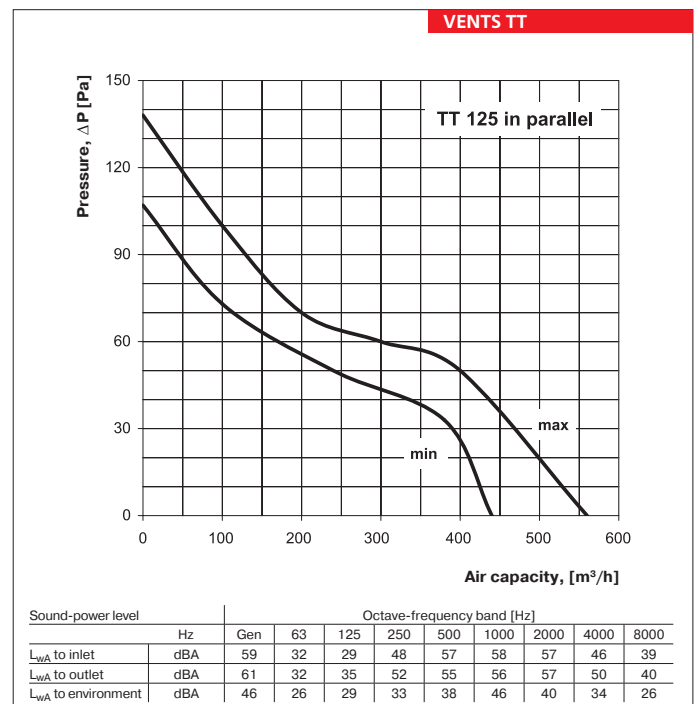
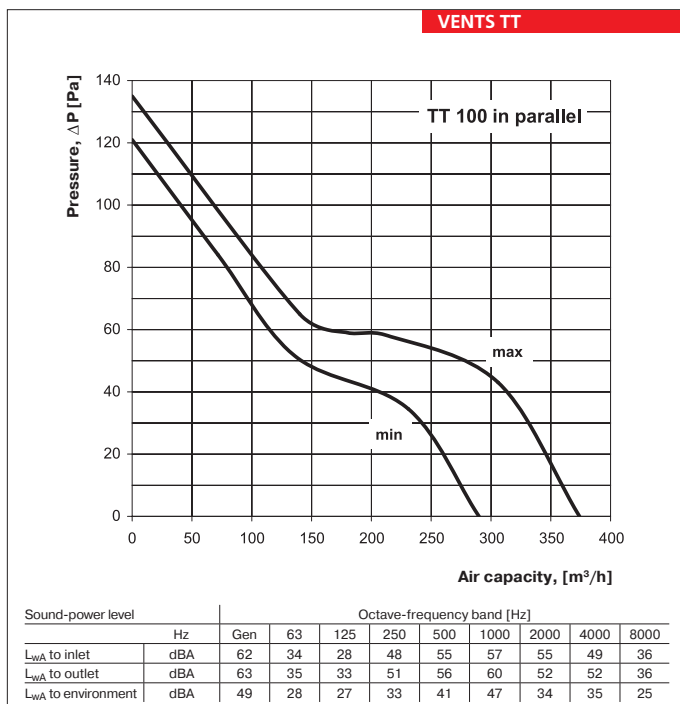

**Technical data:**

	TT 160 in parallel		TT 200 in parallel		TT 250 in parallel		TT 315 in parallel	
Speed	min.	max.	min.	max.	min.	max.	min.	max.
Voltage [V / 50 Hz]	1~ 230		1~ 230		1~ 230		1~ 230	
Power [W]	60	120	180	250	250	354	450	660
Current [A]	0,34	0,54	0,80	1,10	1,08	1,58	1,96	2,86
Maximum air flow [m <sup>3</sup> /h]	934	1104	1660	2080	2220	2800	3520	4700
RPM [min <sup>-1</sup> ]	1670	2450	2045	2510	1955	2440	1980	2660
Noise level at 3 m [dBA]	39	49	51	57	54	61	55	65
Maximum operating temperature [°C]	60		60		60		60	
Protection rating	IP X4		IP X4		IP X4		IP X4	

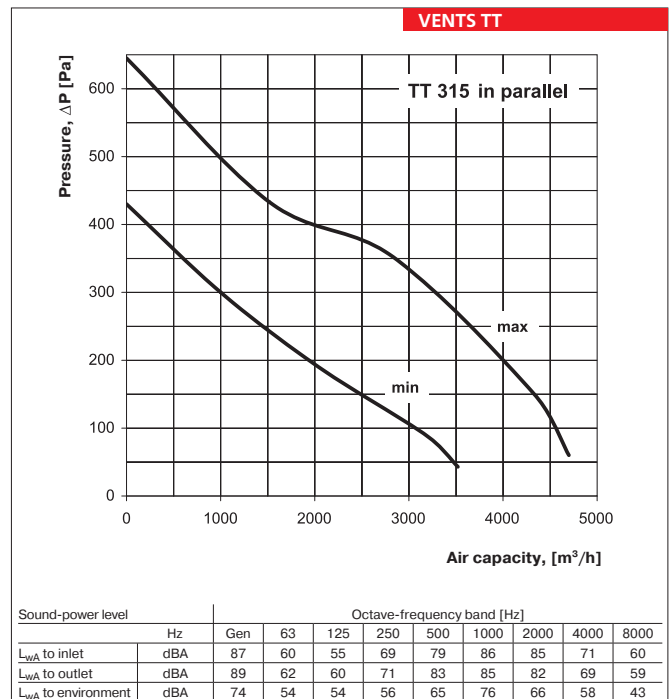
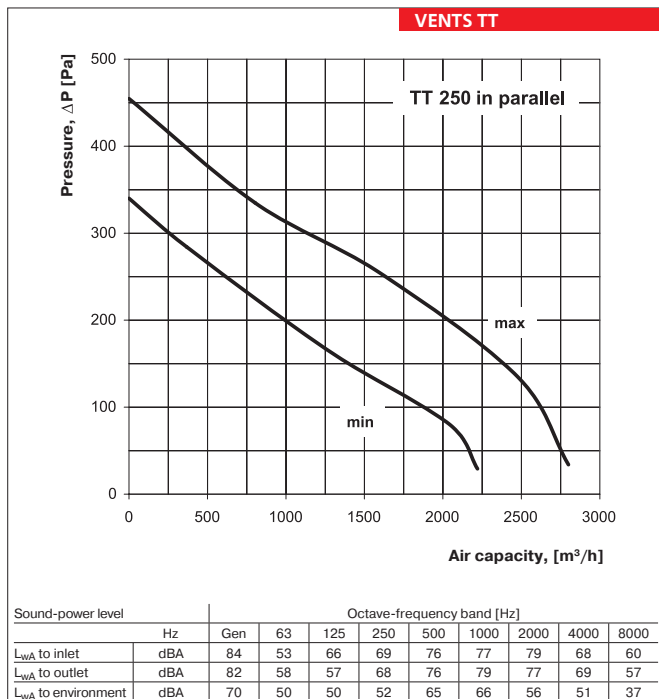
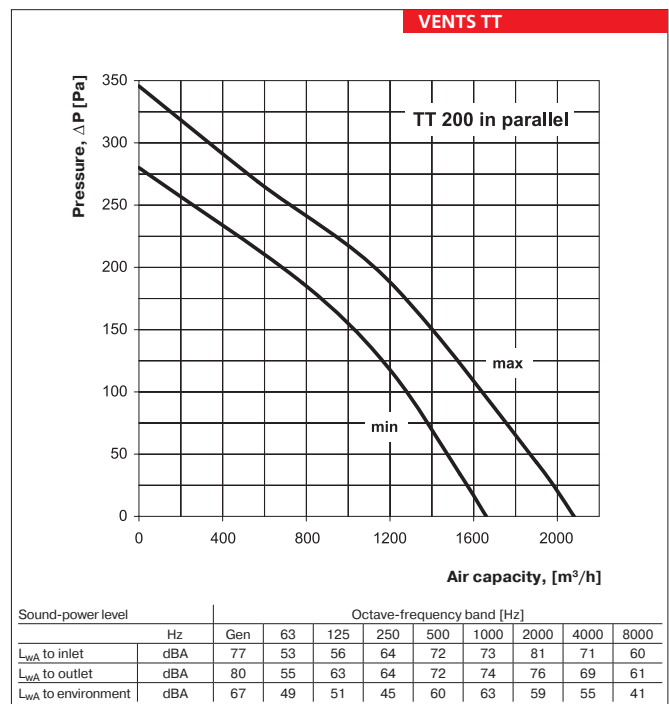
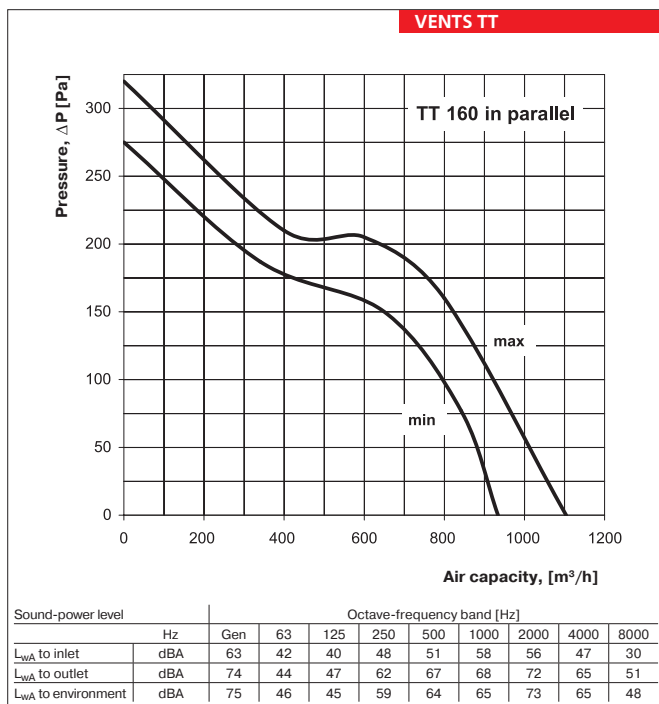



## FANS FOR ROUND DUCTS

### Fan overall dimensions:

Type	Dimensions [mm]					Mass [kg]
	∅D	∅D1	B	H	L	
TT 100	96	140	167	190	246	1,4
TT 125	123	140	167	190	246	1,4
TT 125 S	123	195	223	250	295	3,0
TT 150	146	195	223	250	295	3,0
TT 160	158	195	233	250	295	3,0
TT 200	199	209	239	261	295,5	6,4
TT 250	247	257	287	323	383	8,3
TT 315	310	323	362	408	445	11,4

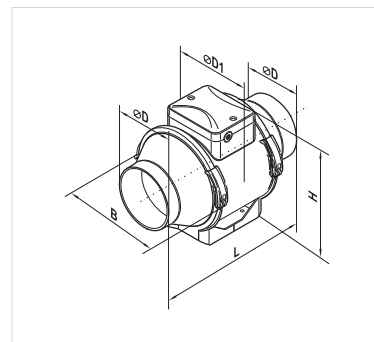

### Overall dimensions for fans connected in series:

Type	Dimensions [mm]							Mass [kg]
	∅D	∅D1	B	B1	H	L	L1	
TT 100 in series	96	140	167	140	196	492	372	3,3
TT 125 in series	123	140	167	140	196	492	372	3,3
TT 125 S in series	123	195	223	140	256	590	440	6,3
TT 150 in series	148	195	223	140	256	590	440	6,3
TT 160 in series	158	195	233	140	256	590	440	6,3
TT 200 in series	197	209	239	190	270	595	440	13,5
TT 250 in series	247	257	287	190	331	766	580	17,6
TT 315 in series	310	323	362	240	420	890	700	24,2

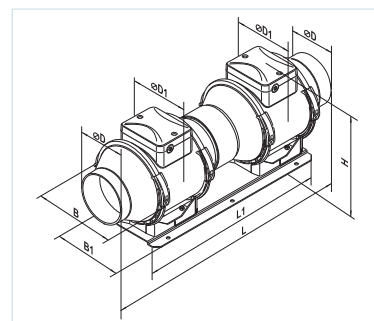

### Overall dimensions for fans connected in parallel:

Type	Dimensions [mm]										Mass [kg]
	∅D	∅D1	B	B1	B2	H	H1	H2	L	L1	
TT 100 in parallel	100	140	320	300	380	185	160	178	246	140	4
TT 125 in parallel	125	140	320	300	380	185	160	178	261	140	4
TT 125 S in parallel	125	195	395	375	430	228	200	220	295	180	7,5
TT 150 in parallel	150	195	395	375	430	228	200	220	310	180	7,5
TT 160 in parallel	160	195	395	375	430	228	200	220	310	180	7,6
TT 200 in parallel	200	209	450	420	492	225	220	240	306	190	15,2
TT 250 in parallel	250	257	580	520	625	287	270	290	398	240	22,5
TT 315 in parallel	315	323	690	670	740	366	335	355	465	340	28,4

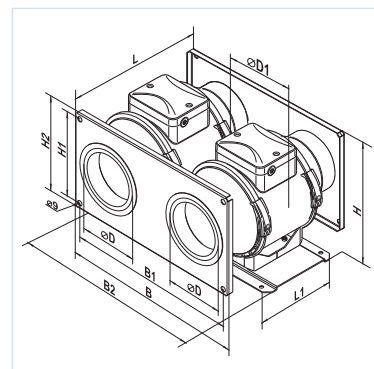

■ TT fans applications

▶ bathroom ventilation example



▶ office ventilation example



▶ Parallel installation of fans in the storehouse to increase the air capacity



Series  
**VENTS VK**



In-line centrifugal fans in plastic casing with the air capacity up to **1700 m<sup>3</sup>/h**

■ **Applications**

VK fans are applied for supply and exhaust ventilation systems of commercial, office and other premises. Compatible with Ø 100, 125, 150, 200, 250 and 315 mm round air ducts. Models marked VK...Q are supplied with quiet motors for low-noise applications. Due to the corrosion-resistant durable plastic casing, these models are the perfect solution for the installation in exhaust ventilation systems in humid premises such as bathrooms, kitchens etc.

■ **Design**

The casing is made of high-quality durable ABS plastic. The fans are equipped with waterproof terminal boxes. Models marked VK..R are supplied with the power cord and a plug.

■ **Motor**

The impeller with backward curved blades is powered by a single-phase asynchronous AC motor with external rotor including the following features:

- ▶ A dynamic balanced impeller with backward curved blades balanced in two planes.

- ▶ Overheating protection with automatic restart.
- ▶ Maintenance-free ball-bearings used with motors and designed for at least 40 000 hours operation. Models marked VKS are supplied with high-powered motors. Motor protection rating IP 44.

■ **Speed control**

Smooth or stepped speed control can be performed by external thymistor or transformer. Several fans can be connected to one speed controller if the total power and operating current of fans do not exceed the rated controller values.

■ **Mounting**

Installation to the wall or ceiling can be performed by means of mounting brackets (included in the delivery) or with additional PVK holders (available upon request). The fan can be mounted at any angle. Electric connection and installation shall be performed in compliance with the manual and the wiring diagram on the terminal box.

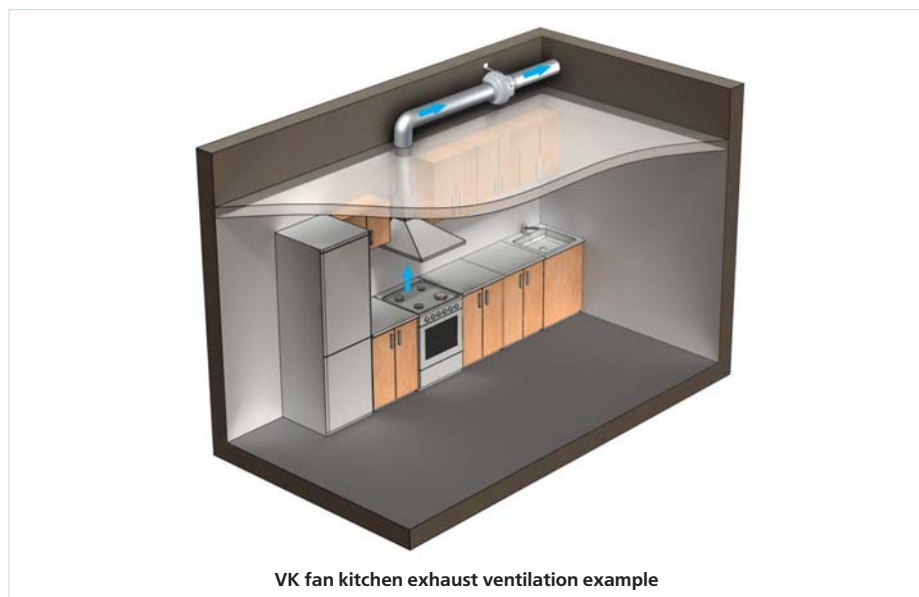

VK fan kitchen exhaust ventilation example

Designation key: \_\_\_\_\_

Fan series	
<b>VENTS VK</b>	<b>S</b> – high-powered motor

Duct diameter
100; 125; 150*; 200; 250; 315

Additional options
<b>Q</b> – low-noise application;
<b>U</b> – speed controller module with the built in temperature sensor;
<b>Un</b> – speed controller module with the external temperature sensor;
<b>U1</b> – speed controller with the built in timer and temperature sensor;
<b>U1n</b> – speed controller with the built in timer and external temperature sensor;
<b>R</b> – power cord and C14 plug.

\* VK 150 model is compatible with the air ducts both Ø 150 and 160 mm

Accessories



page 240    page 248    page 250    page 254    page 262    page 294    page 296    page 304    page 310    page 310    page 314    page 315

**Automatic speed control module**

VK..U1 and VK..U1n are the perfect solution for greenhouses and other premises requiring air temperature control. These models are fitted with an integrated electronic speed control module TSC with temperature sensor that provides automatic speed regulation as a function of air temperature in the duct (VK..U1 with integrated temperature sensor) or directly in the ventilated area (VK..U1n with external temperature sensor).

Temperature and minimum speed can be adjusted with two control knobs on the controller panel.

The external temperature sensor (in VK..Un and VK..U1n models) is supplied with 4 m cable and a protecting cover against mechanical damage. The LED indicator for thermostat operation is placed at the front panel of the fan.

**Automatic speed controller pattern for VK fans.**

Set points for the maximum air temperature and the fan speed are manually adjusted by the control knobs. Normally the fan operates with the speed which is set by the knob. If the temperature exceeds the set point, the fan boosts to the maximum speed. After that when the temperature drops down below the set point, the fan goes back to preset speed. The switching delay disables frequent motor switching if the set temperature in the duct is equal to the threshold temperature.

There are two patters of delay that may be used in various cases:

1. Temperature sensor delay (VK..U): if the temperature rises by 2°C above the set thermostat operating threshold the motor switches to the

increased speed. The motor switches to the preset (low) speed as the temperature drops below the set threshold. This pattern can be used to keep air temperature to within 2°C. In this case the fan switches are rare.

2. Timer delay (VK..U1): the motor sets to higher speed 5 min after the temperature exceeds the set threshold. The motor switches to the preset (low) speed 5 min. after the temperature drops below the set threshold.

This pattern can be used to keep the air temperature at a precise level. In this case the fan switches more frequently than in the pattern of temperature sensor delay, but the intervals do not exceed 5 minutes.

**Example for temperature sensor delay pattern:**

Initial conditions:

- rated speed is set as 60% of the maximum speed
- operating threshold is set as 25°C
- air temperature in the duct is 20°C

motor operates with the rated speed =60%

- air temperature in the duct rises

motor operates with the rated speed =60%

- air temperature in the duct reaches 27°C

motor switches to the speed =100%

air temperature in the duct goes down

mototr operates with the speed =100%

- temperature in the duct reaches 25°C again

motor switches to the preset rated speed =60%

**Example for timer delay pattern:**

Initial conditions:

- rated speed is set as 60% of maximum speed
- operating threshold is set as 25°C
- air temperature in the duct is 20°C

motor operates with the rated speed =60%

- the temperature in the duct rises, reaches 25°C and keeps rising

fan switches to the maximum speed =100% and the delay timer switches for 5 minutes again on

- the temperature in the duct goes down  
the motor operates with the maximum speed =100%

- the temperature in the duct reaches 25°C and keeps rising

after the timer stops, the motor switches to the preset rated speed (=60%). After the speed switch the timer switches again for 5 minutes on.

- the temperature in the duct rises, reaches 25°C and keeps rising

after the timer stops, the motor switches to the maximum speed (=100%). After the speed switch the delay timer switches again for 5 minutes on.

Thus, in timer delay pattern the delay timer activates every time the fan speed changes.

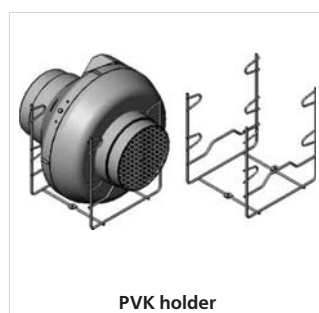



# FANS FOR ROUND DUCTS

## Technical data:

	VK 100 Q	VK 100	VK 125 Q	VK 125	VK 150	VK 200	VKS 200
Voltage [V / 50 Hz]	230	230	230	230	230	230	230
Power [W]	62	80	61	79	80	107	173
Current [A]	0,38	0,34	0,38	0,34	0,35	0,47	0,76
Maximum air flow [m <sup>3</sup> /h]	205	250	260	355	460	780	930
RPM [min <sup>-1</sup> ]	2650	2820	2610	2800	2725	2660	2125
Noise level at 3 m [dBA]	36	46	36	46	46	48	51
Maximum operating temperature [°C]	-25 +55	-25 +55	-25 +55	-25 +55	-25 +55	-25 +50	-25 +45
Protection rating	IP X4	IP X4	IP X4	IP X4	IP X4	IP X4	IP X4

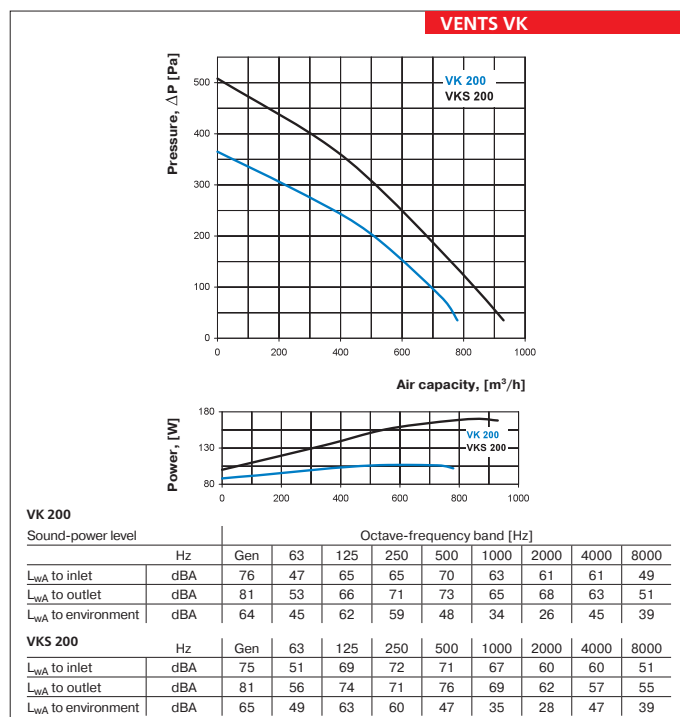
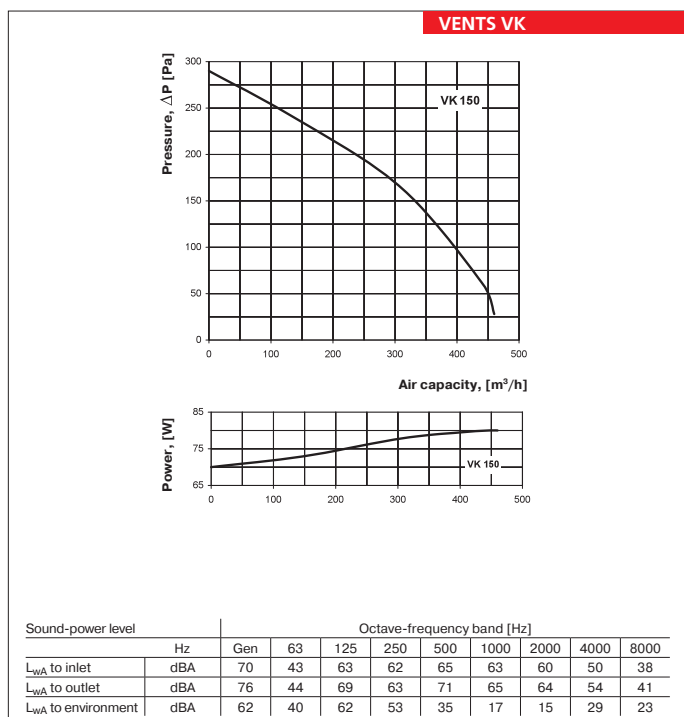
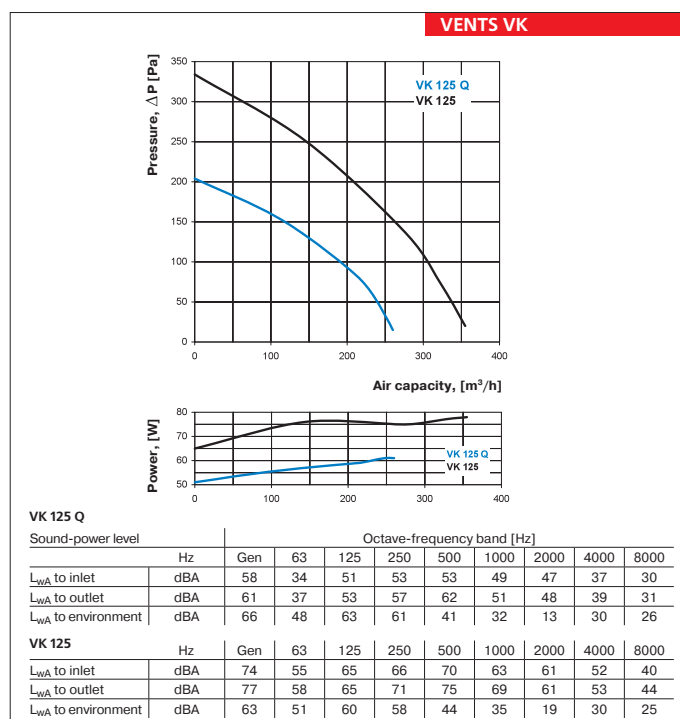
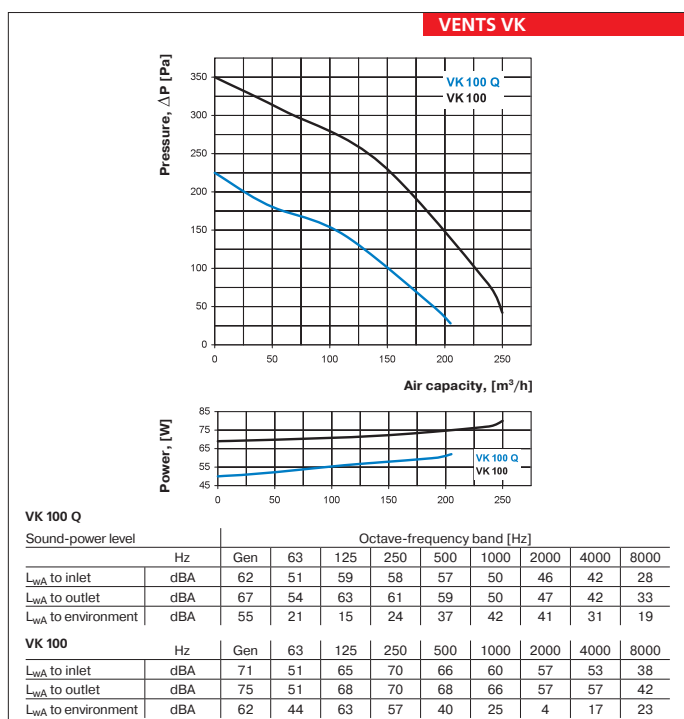

**Technical data:**

	VK 250 Q	VK 250	VK 315	VKS 315
Voltage [V / 50 Hz]	230	230	230	230
Power [W]	108	173	200	310
Current [A]	0,47	0,76	0,88	1,36
Maximum air flow [m <sup>3</sup> /h]	865	1080	1340	1700
RPM [min <sup>-1</sup> ]	2560	2090	2655	2590
Noise level at 3 m [dBA]	51	50	50	53
Maximum operating temperature [°C]	-25 +50	-25 +50	-25 +50	-25 +45
Protection rating	IP X4	IP X4	IP X4	IP X4

FAN SERIES VENTS VK

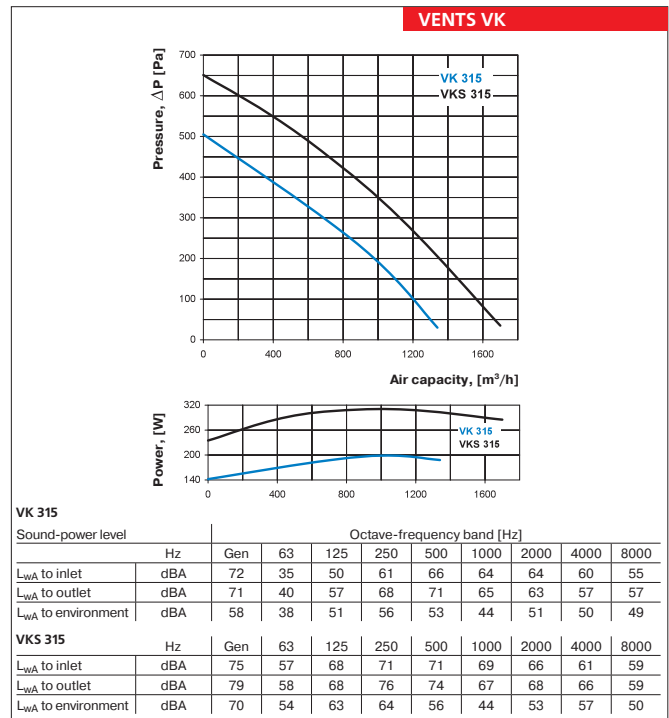
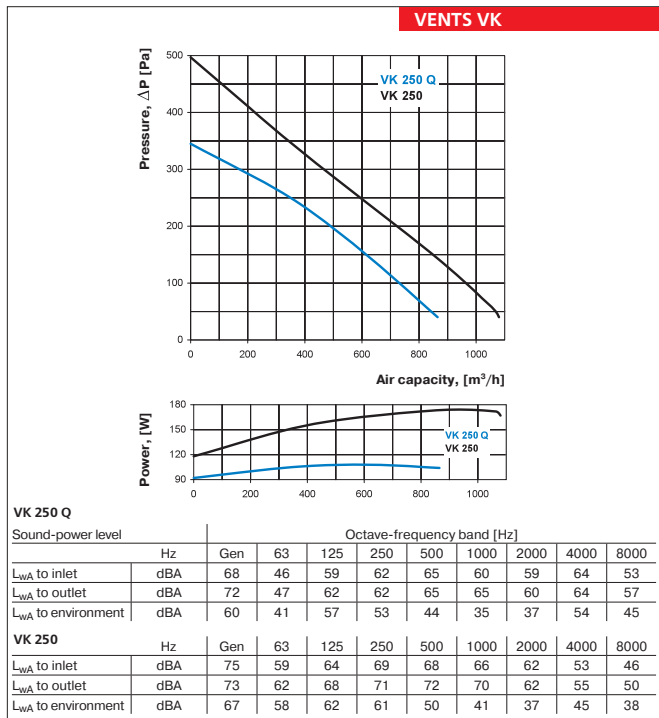

**Fan overall dimensions:**

Type	Dimensions [mm]								Mass [kg]
	∅D	∅D1	B	L	L1	L2	L3		
VK 100 Q / VK 100	100	250	270	230	30	27	30	2,15	
VK 125 Q / VK 125	125	250	270	220	30	27	30	2,2	
VK 150	150 / 160	300	310	286	30	30	30	2,6	
VK 200	200	340	354	276	30	30	40	4,0	
VKS 200	200	340	354	276	30	30	40	4,3	
VK 250 Q / VK 250	250	340	354	265	30	30	40	4,5	
VK 315	315	400	414	276	40	55	40	5,1	
VKS 315	315	400	414	276	40	55	40	5,2	

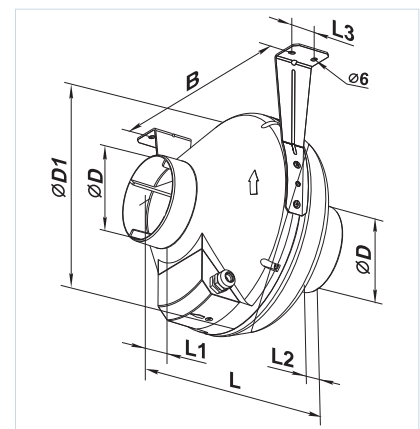

Series  
**VK VMS 125**



Multiple-inlet centrifugal fan in plastic casing with the air capacity up to **335 m<sup>3</sup>/h**

■ **Applications**

VK VMS 125 is a multiple-inlet fan designed for simultaneous air exhaust from up to 5 premises. It is a perfect solution for bathroom units, kitchens and other residential and small commercial premises requiring exhaust ventilation due to increased humidity. The fan is equipped with four Ø 80 mm inlet branch pipes and one Ø 125 mm intake branch pipe.

■ **Design**

The fan is equipped with a high-quality plastic casing and a waterproof terminal box. For easy connection and operation the power cord with a plug can be provided (VK VMS... R).

■ **Motor**

The impeller with backward curved blades is powered by single-phase motor with external rotor and overheating protection with automatic restart. The motor is equipped with ball bearings for long service life designed for at least 40 000 hours.

■ **Speed control**

Smooth or step speed control is performed with thyristor or autotransformer controller.

■ **Mounting**

Easy to mount. Mounting at any angle to wall or ceiling is performed by means of fastening brackets.



VK VMS 125 R model equipped with the power cord.

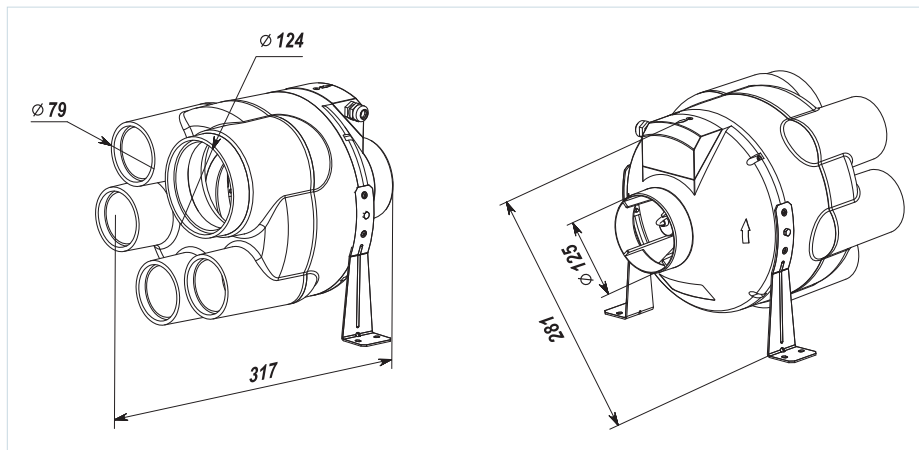

**Designation key:** \_\_\_\_\_

Fan series	Duct diameter	Additional options
<b>VK VMS</b>	125	<b>R</b> – power cord with a C14 plug.

**Accessories**



page 240    page 294    page 296    page 304    page 310    page 310    page 314    page 315

**Technical data:**

<b>VK VMS 125</b>	
Voltage [V / 50 Hz]	230
Power [W]	79
Current [A]	0,34
Maximum air flow [m <sup>3</sup> /h]	355
RPM [min <sup>-1</sup> ]	2800
Noise level at 3 m [dBA]	46
Maximum operating temperature [°C]	-25 +55
Protection rating	IP X4

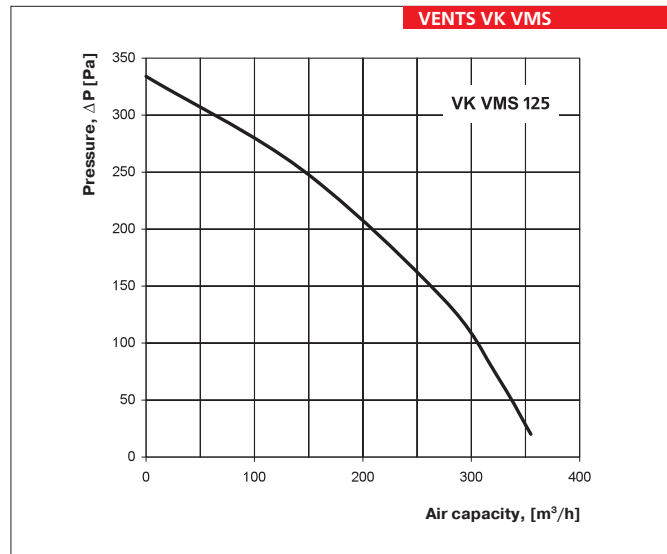

VENTS  
VK VMS  
FAN SERIES

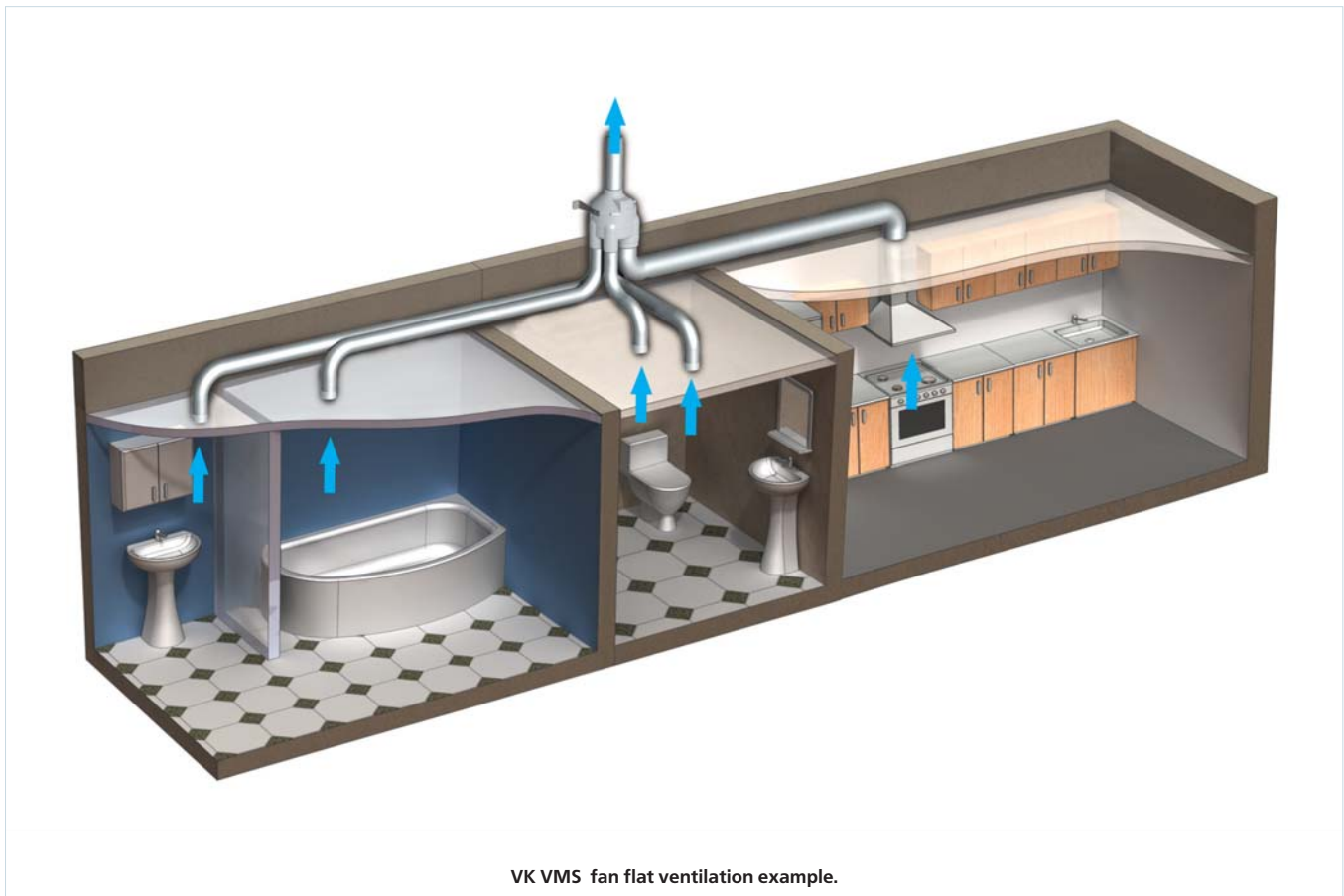



Series  
**VENTS VKM 100-315**



Series  
**VENTS VKM 355-450**



In-line centrifugal fans in steel casing with the air capacity up to **5260 m<sup>3</sup>/h**

■ **Applications**

Supply and exhaust systems for various premises. The steel casing provides reliable operation in case of outdoor installation. For premises with high requirements to the noise level we suggest units in low-noise modification (VKM...Q).

■ **Design**

The fan casing is made of steel with polymeric coating. For easy connection and operation the power cord with a plug can be provided (VKM...R).

■ **Motor**

The impeller with backward curved blades is powered by the single-phase motor with external rotor and overheating protection with automatic restart. Some standard sizes are available in high-powered modifications (VKMS). The motor is equipped with ball bearings for long service life designed for at least

40 000 hours. For precise features, safe operation and low noise, each turbine is dynamically balanced while assembly. Motor protection rating IP 44.

■ **Speed control**

Smooth or step speed control is performed with thyristor or autotransformer controller. Several fans can be connected to one controller in case the total power and operating current do not exceed the controller rated values.

■ **Mounting**

Mounting to wall or ceiling at any angle is performed with fastening brackets supplied with the unit. The fan is powered through the external terminal box. Electric connection and installation shall be performed in compliance with the manual and wiring diagram on the terminal box.

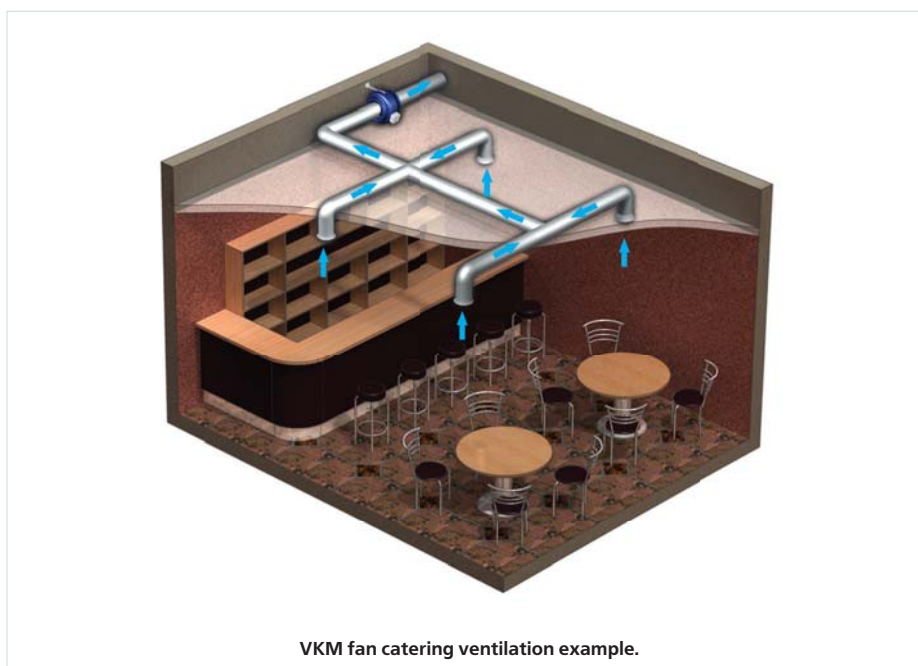

VKM fan catering ventilation example.

Designation key: \_\_\_\_\_

Fan series		Duct diameter	Additional options
<b>VENTS VKM</b>	<b>S</b> – high-powered motor	100; 125; 150; 160; 200; 250; 315; 355; 400; 450	<b>Q</b> – low-noise design; <b>P</b> – supply cable with a C14 plug

Accessories



page 240    page 248    page 250    page 254    page 262    page 294    page 296    page 304    page 310    page 310    page 314    page 315

**Fan overall dimensions:**

Type	Dimensions [mm]								Mass [kg]
	∅D	∅D1	B	B1	L	L1	L2	L3	
VKM 100 Q	98	254	298	258	205	20	25	30	4,2
VKM 100	98	254	298	258	205	20	25	30	4,4
VKM 125 Q	123	254	298	258	205	20	25	30	4,1
VKM 125	123	254	298	258	205	20	25	30	4,3
VKM 150	149	304	349	309	220	25	25	30	5,4
VKM 160	159	304	357	317	220	25	25	30	5,6
VKM 200	198	344	390	350	240	25	29	40	6,6
VKMS 200	198	344	390	350	250	25	29	40	6,7
VKM 250 Q	248	344	390	350	249	25	31	40	7,1
VKM 250	248	344	390	350	249	25	31	40	7,3
VKM 315	314	404	454	414	260	25	40	40	8,1
VKMS 315	314	404	454	414	288	25	40	40	8,2
VKM 355 B	353	460	522	522	506	60	60	70	12,8
VKM 400	398	570	663	634	570	60	60	70	20,0
VKM 450	448	608	700	670	644	60	60	80	30,0

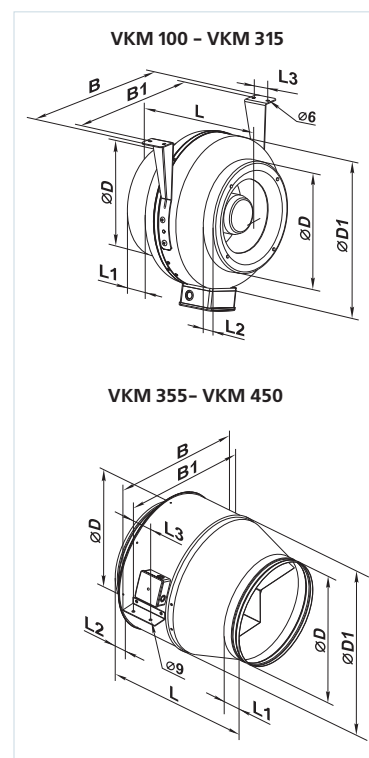

**Technical data:**

	VKM 100 Q	VKM 100	VKM 125 Q	VKM 125	VKM 150	VKM 160	VKM 200	VKMS 200
Voltage [V / 50 Hz]	230	230	230	230	230	230	230	230
Power [W]	60	73	60	75	98	98	154	193
Current [A]	0,37	0,32	0,37	0,33	0,43	0,43	0,67	0,84
Maximum air flow [m³/h]	210	270	255	355	555	555	950	1100
RPM [min <sup>-1</sup> ]	2620	2830	2535	2800	2705	2660	2375	2780
Noise level at 3 m [dBA]	36	47	36	47	47	47	48	51
Maximum operating temperature [°C]	-25 +55	-25 +55	-25 +55	-25 +55	-25 +55	-25 +55	-25 +50	-25 +45
Protection rating	IP X4	IP X4	IP X4	IP X4	IP X4	IP X4	IP X4	IP X4

**Technical data:**

	VKM 250 Q	VKM 250	VKM 315	VKMS 315	VKM 355 Q	VKM 400	VKM 450
Voltage [V / 50 Hz]	230	230	230	230	230	230	230
Power [W]	158	194	171	296	233	460	665
Current [A]	0,69	0,85	0,77	1,34	1,06	2,23	2,89
Maximum air flow [m³/h]	1190	1310	1400	1880	2210	3050	5260
RPM [min <sup>-1</sup> ]	2315	2790	2600	2720	1375	1370	1265
Noise level at 3 m [dBA]	52	52	52	54	58	61	65
Maximum operating temperature [°C]	-25 +50	-25 +50	-25 +50	-25 +45	-25 +45	-40 +80	-40 +70
Protection rating	IP X4	IP X4	IP X4	IP X4	IP X4	IP X4	IP X4

VENTS VKM

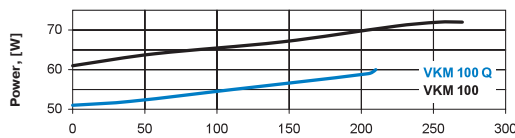
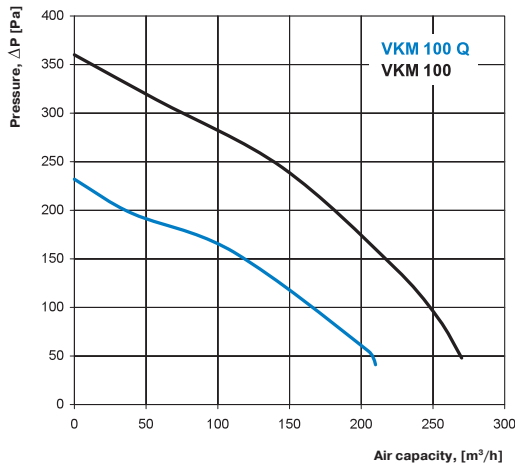

VKM 100 Q

Sound-power level	Hz	Gen	Octave-frequency band [Hz]							
			63	125	250	500	1000	2000	4000	8000
$L_{WA}$ to inlet	dBA	64	48	57	57	59	51	47	40	28
$L_{WA}$ to outlet	dBA	64	52	62	56	57	50	46	39	32
$L_{WA}$ to environment	dBA	57	23	13	23	38	42	42	31	15

VKM 100

Sound-power level	Hz	Gen	Octave-frequency band [Hz]							
			63	125	250	500	1000	2000	4000	8000
$L_{WA}$ to inlet	dBA	73	47	63	67	68	60	55	54	38
$L_{WA}$ to outlet	dBA	77	54	66	73	66	66	60	55	46
$L_{WA}$ to environment	dBA	63	45	60	55	41	25	7	18	22

VENTS VKM

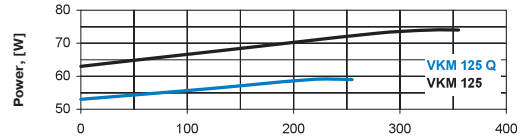
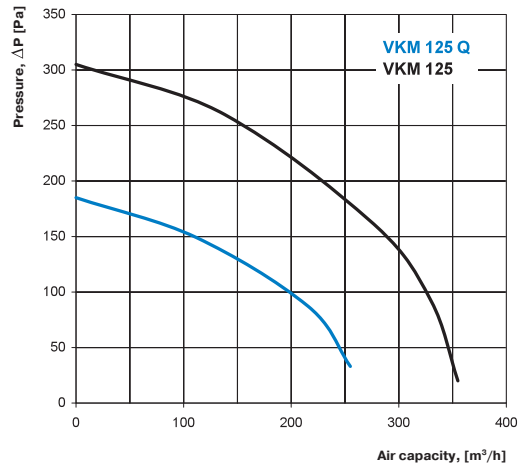

VKM 125 Q

Sound-power level	Hz	Gen	Octave-frequency band [Hz]							
			63	125	250	500	1000	2000	4000	8000
$L_{WA}$ to inlet	dBA	60	34	51	53	56	46	43	34	29
$L_{WA}$ to outlet	dBA	62	33	52	59	58	51	49	41	32
$L_{WA}$ to environment	dBA	65	44	61	59	43	30	17	30	28

VKM 125

Sound-power level	Hz	Gen	Octave-frequency band [Hz]							
			63	125	250	500	1000	2000	4000	8000
$L_{WA}$ to inlet	dBA	73	54	67	68	67	64	61	51	41
$L_{WA}$ to outlet	dBA	76	57	69	68	72	71	65	57	45
$L_{WA}$ to environment	dBA	62	51	61	60	46	36	22	31	27

VENTS VKM

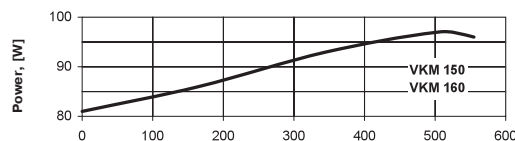
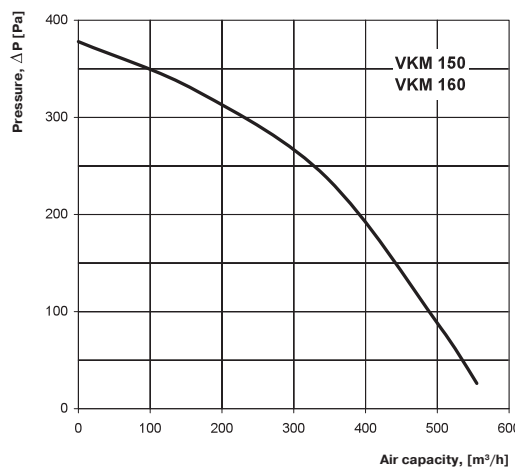

VKM 150

Sound-power level	Hz	Gen	Octave-frequency band [Hz]							
			63	125	250	500	1000	2000	4000	8000
$L_{WA}$ to inlet	dBA	72	45	65	62	67	59	59	49	38
$L_{WA}$ to outlet	dBA	74	42	69	63	71	63	59	50	37
$L_{WA}$ to environment	dBA	62	41	59	55	39	19	17	28	22

VKM 160

Sound-power level	Hz	Gen	Octave-frequency band [Hz]							
			63	125	250	500	1000	2000	4000	8000
$L_{WA}$ to inlet	dBA	68	41	65	64	63	61	57	47	35
$L_{WA}$ to outlet	dBA	70	47	67	68	66	64	60	51	41
$L_{WA}$ to environment	dBA	60	40	61	55	39	18	16	28	22

VENTS VKM

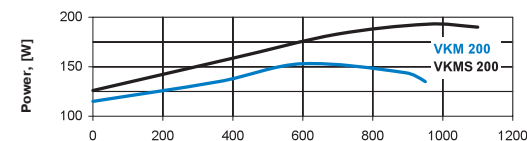
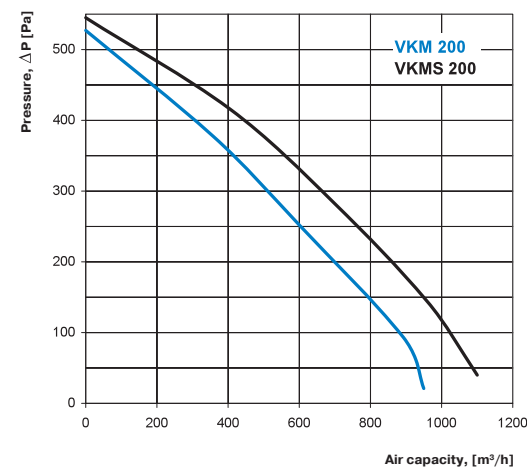

VKM 200

Sound-power level	Hz	Gen	Octave-frequency band [Hz]							
			63	125	250	500	1000	2000	4000	8000
$L_{WA}$ to inlet	dBA	75	47	68	65	72	65	61	59	49
$L_{WA}$ to outlet	dBA	75	51	72	68	75	67	65	59	50
$L_{WA}$ to environment	dBA	65	46	61	59	47	31	28	46	42

VKMS 200

Sound-power level	Hz	Gen	Octave-frequency band [Hz]							
			63	125	250	500	1000	2000	4000	8000
$L_{WA}$ to inlet	dBA	75	48	66	72	73	66	63	58	49
$L_{WA}$ to outlet	dBA	78	51	70	74	71	64	64	60	53
$L_{WA}$ to environment	dBA	66	49	64	60	45	35	28	46	41

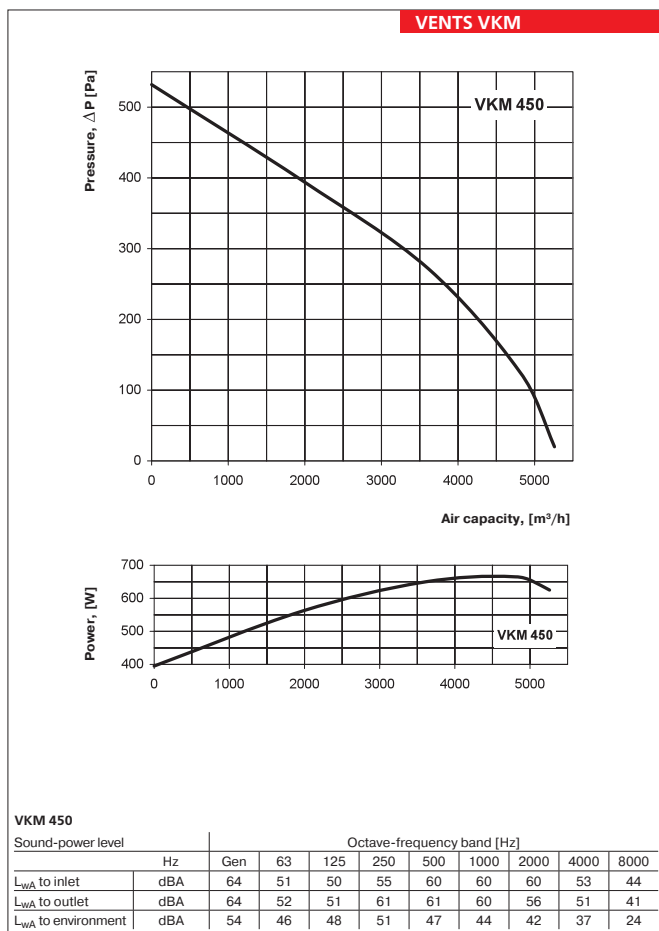
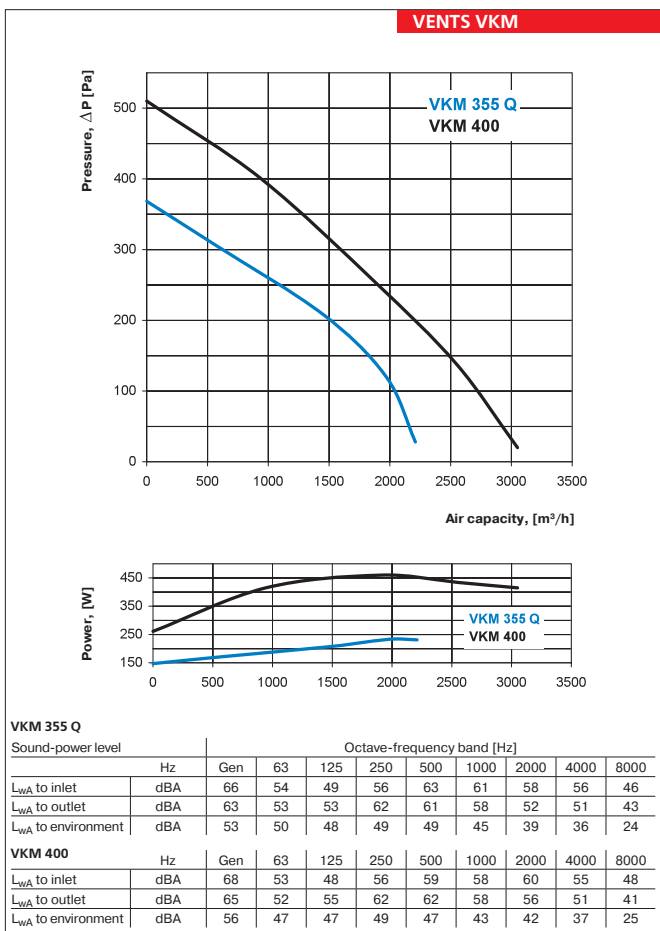
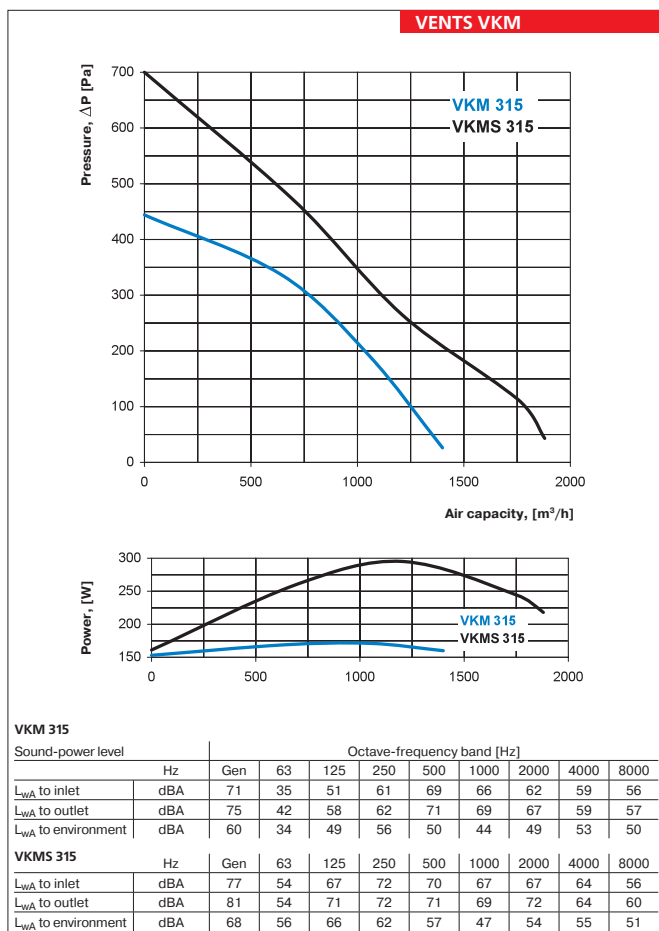
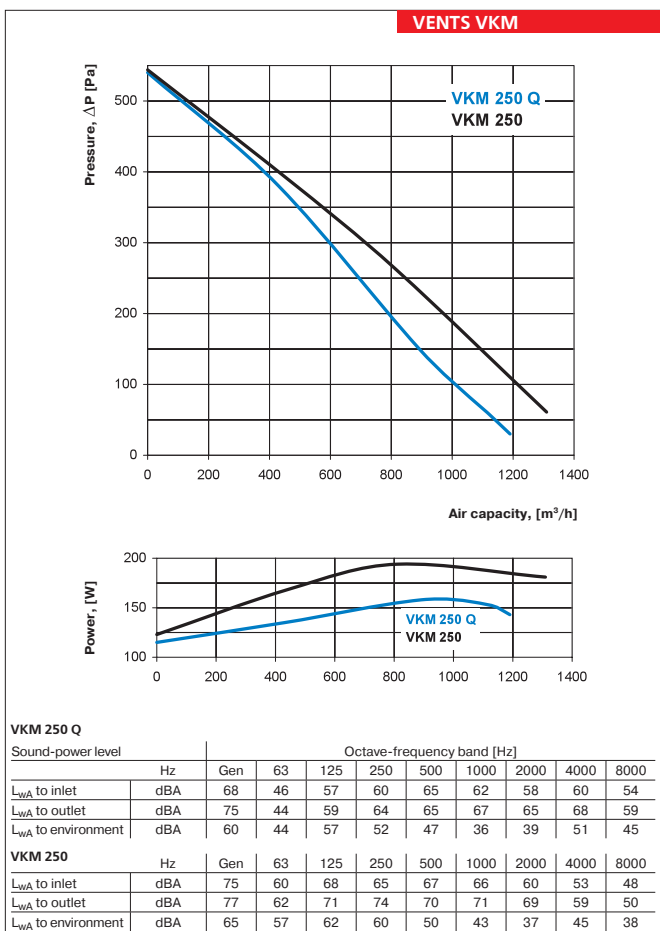



Series  
**VENTS VKMz**



In-line centrifugal fans in galvanized casing with the air capacity up to **1540 m<sup>3</sup>/h**

■ **Applications**

Supply and exhaust ventilation systems for various premises suitable for external surface mounting. For premises with high requirements to noise level we offer units in low-noise modification (VKMz..Q).

■ **Design**

The fan casing is made of galvanized steel. For easy connection and operation the fan can be equipped with the power cord with a plug (VKMz..R).

■ **Motor**

The impeller with backward blades is powered by the single-phase motor with external rotor and overheating protection with automatic restart. The motor is equipped with ball bearings for long service life designed for at least 40 000 hours. For precise features, safe operation and low noise, each impeller is dynamically balanced while assembly. Motor protection rating IP 44.

■ **Speed control**

Both smooth and step speed control is performed with the thyristor or autotransformer controller. Several fans can be connected to one controller in case the total power and operating current do not exceed the rated controller values.

■ **Mounting**

Mounting at any angle to wall or ceiling is performed with fastening brackets supplied with the unit. The fan is powered by means of the external terminal box. Electric connection and mounting shall be performed in compliance with the manual and wiring diagram on the terminal box.

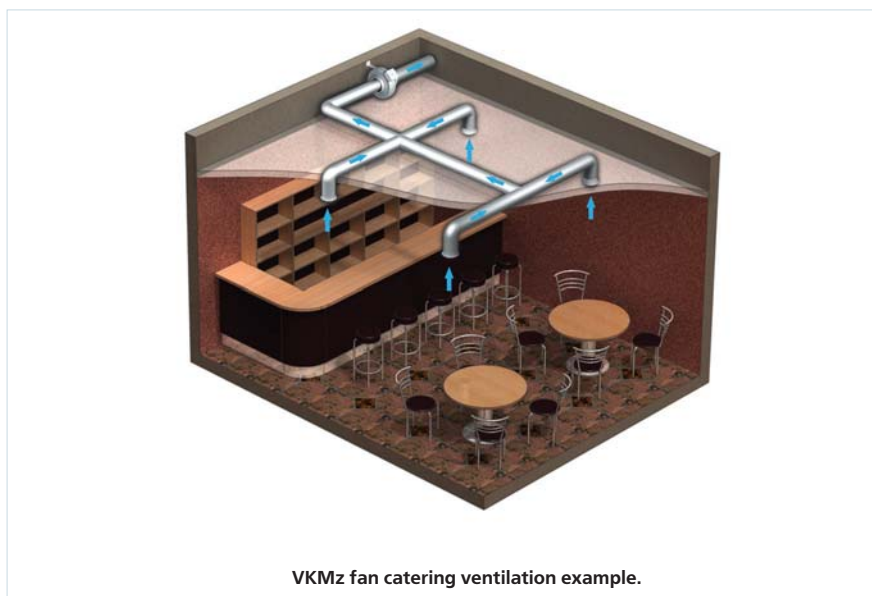

VKMz fan catering ventilation example.

Designation key: \_\_\_\_\_

Fan series	Flange diameter	Additional options
<b>VENTS VKMz</b>	100; 125; 150; 160; 200; 250; 315	<b>Q</b> – low-noise design; <b>R</b> – power cord with C14 plug.

Accessories



page 240    page 248    page 250    page 254    page 262    page 294    page 296    page 304    page 310    page 310    page 314    page 315

**Technical data:**

	VKMz 100 Q	VKMz 100	VKMz 125 Q	VKMz 125	VKMz 150	VKMz 160
Voltage [V / 50 Hz]	230	230	230	230	230	230
Power [W]	60	72	60	78	75	78
Current [A]	0,37	0,32	0,37	0,34	0,33	0,34
Maximum air flow [m³/h]	195	250	230	330	455	455
RPM [min <sup>-1</sup> ]	2670	2820	2605	2820	2770	2760
Noise level at 3 m [dBA]	35	46	35	46	46	46
Maximum operating temperature [°C]	-25 +55	-25 +55	-25 +55	-25 +55	-25 +55	-25 +55
Protection rating	IP X4	IP X4	IP X4	IP X4	IP X4	IP X4

**Technical data:**

	VKMz 200 Q	VKMz 200	VKMz 250 Q	VKMz 250	VKMz 315 Q	VKMz 315
Voltage [V / 50 Hz]	230	230	230	230	230	230
Power [W]	139	157	134	152	151	185
Current [A]	0,61	0,69	0,59	0,66	0,66	0,81
Maximum air flow [m³/h]	840	1000	980	1070	1330	1540
RPM [min <sup>-1</sup> ]	2790	2740	2785	2765	2680	2730
Noise level at 3 m [dBA]	48	50	51	52	52	53
Maximum operating temperature [°C]	-25 +50	-25 +45	-25 +50	-25 +50	-25 +50	-25 +45
Protection rating	IP X4	IP X4	IP X4	IP X4	IP X4	IP X4

**Fan overall dimensions:**

Type	Dimensions [mm]								Mass [kg]
	∅D	∅D1	B	B1	L	L1	L2	L3	
VKMz 100 Q	98	237	253	293	202	23	22	30	3,1
VKMz 100	98	237	253	293	202	23	22	30	3,2
VKMz 125 Q	123	237	253	293	202	23	22	30	3,1
VKMz 125	123	237	253	293	202	23	22	30	3,15
VKMz 150	148	278	294	334	200	25	23	30	3,8
VKMz 160	158	278	294	334	200	25	23	30	3,8
VKMz 200 Q	198	332	340	380	245	25	29	40	4,2
VKMz 200	198	332	340	380	245	25	29	40	4,4
VKMz 250 Q	249	332	340	380	213	25	29	40	4,1
VKMz 250	249	332	340	380	213	25	29	40	4,3
VKMz 315 Q	313	402	410	450	308	33	55	40	5,5
VKMz 315	313	402	410	450	308	33	55	40	5,7

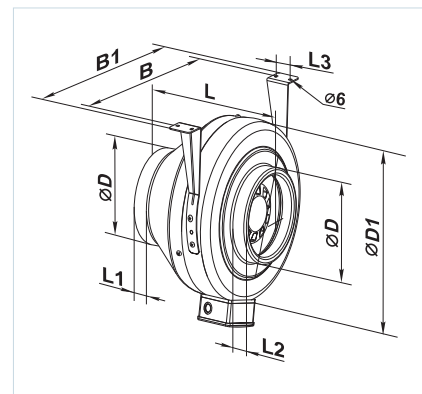

External terminal box for power supply



Fastening bracket for easy mounting supplied with the fan



VENTS VKMZ...R is equipped with the power cord

VENTS VKMz

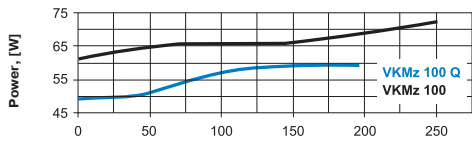
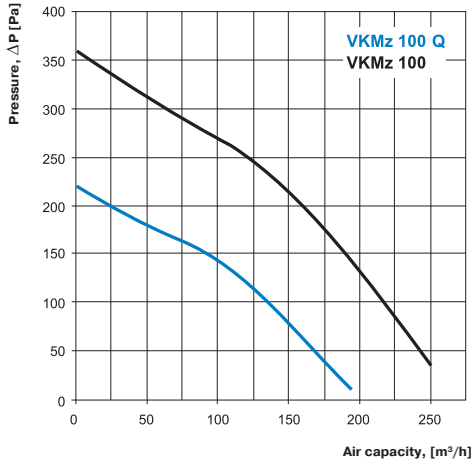

VKMz 100 Q

Sound-power level	Hz	Gen	Octave-frequency band [Hz]							
			63	125	250	500	1000	2000	4000	8000
L <sub>WA</sub> to inlet	dBA	63	51	57	56	57	51	46	40	29
L <sub>WA</sub> to outlet	dBA	65	54	62	58	61	57	50	45	33
L <sub>WA</sub> to environment	dBA	55	19	14	21	34	42	41	29	17

VKMz 100

Sound-power level	Hz	Gen	Octave-frequency band [Hz]							
			63	125	250	500	1000	2000	4000	8000
L <sub>WA</sub> to inlet	dBA	72	47	67	68	67	60	54	53	42
L <sub>WA</sub> to outlet	dBA	73	56	67	72	66	63	58	57	42
L <sub>WA</sub> to environment	dBA	64	43	60	57	41	24	6	17	24

VENTS VKMz

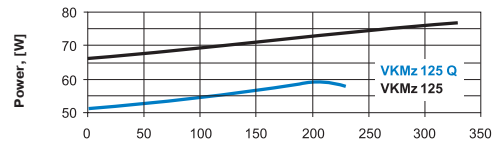
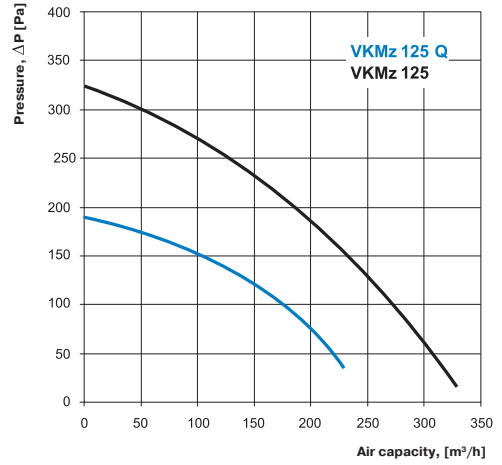

VKMz 125 Q

Sound-power level	Hz	Gen	Octave-frequency band [Hz]							
			63	125	250	500	1000	2000	4000	8000
L <sub>WA</sub> to inlet	dBA	59	31	52	54	53	49	46	35	30
L <sub>WA</sub> to outlet	dBA	61	35	53	56	60	51	49	35	34
L <sub>WA</sub> to environment	dBA	64	46	60	59	43	33	15	30	28

VKMz 125

Sound-power level	Hz	Gen	Octave-frequency band [Hz]							
			63	125	250	500	1000	2000	4000	8000
L <sub>WA</sub> to inlet	dBA	75	56	63	68	69	64	61	52	41
L <sub>WA</sub> to outlet	dBA	75	58	71	74	72	65	65	56	47
L <sub>WA</sub> to environment	dBA	64	52	64	59	48	36	23	30	27

VENTS VKMz

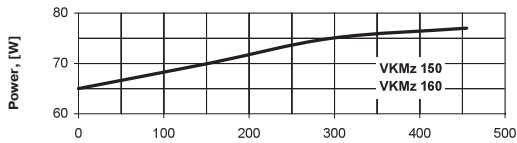
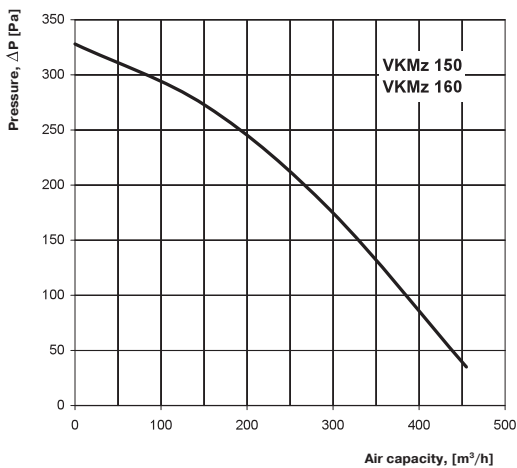

VKMz 150

Sound-power level	Hz	Gen	Octave-frequency band [Hz]							
			63	125	250	500	1000	2000	4000	8000
L <sub>WA</sub> to inlet	dBA	72	42	65	64	64	61	60	48	38
L <sub>WA</sub> to outlet	dBA	73	47	68	66	69	64	59	47	41
L <sub>WA</sub> to environment	dBA	63	41	59	54	37	18	17	29	22

VKMz 160

Sound-power level	Hz	Gen	Octave-frequency band [Hz]							
			63	125	250	500	1000	2000	4000	8000
L <sub>WA</sub> to inlet	dBA	69	42	67	66	63	61	58	48	35
L <sub>WA</sub> to outlet	dBA	72	46	69	65	68	64	63	50	40
L <sub>WA</sub> to environment	dBA	60	41	60	53	36	20	18	30	24

VENTS VKMz

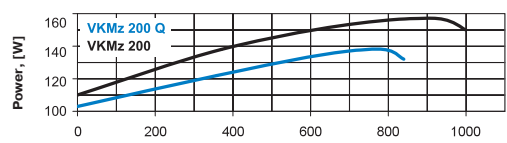
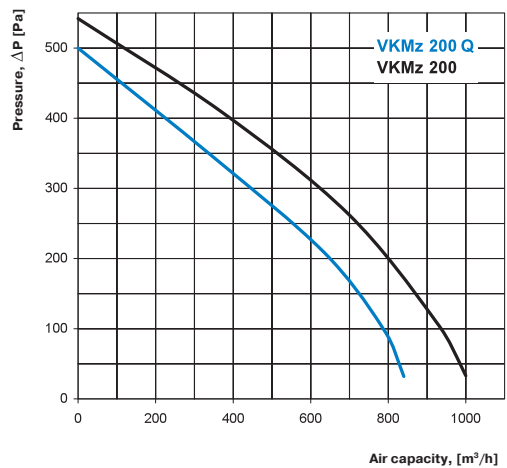

VKMz 200 Q

Sound-power level	Hz	Gen	Octave-frequency band [Hz]							
			63	125	250	500	1000	2000	4000	8000
L <sub>WA</sub> to inlet	dBA	76	47	68	65	70	67	59	58	50
L <sub>WA</sub> to outlet	dBA	76	49	71	69	72	63	63	60	53
L <sub>WA</sub> to environment	dBA	64	46	61	57	48	32	27	48	42

VKMz 200

Sound-power level	Hz	Gen	Octave-frequency band [Hz]							
			63	125	250	500	1000	2000	4000	8000
L <sub>WA</sub> to inlet	dBA	73	51	66	68	71	67	64	58	52
L <sub>WA</sub> to outlet	dBA	79	51	73	69	74	67	65	60	50
L <sub>WA</sub> to environment	dBA	68	47	64	64	46	32	30	44	42

**VENTS VKMZ**

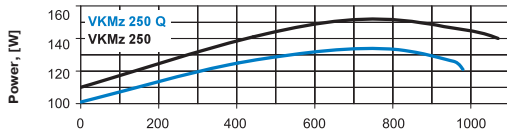
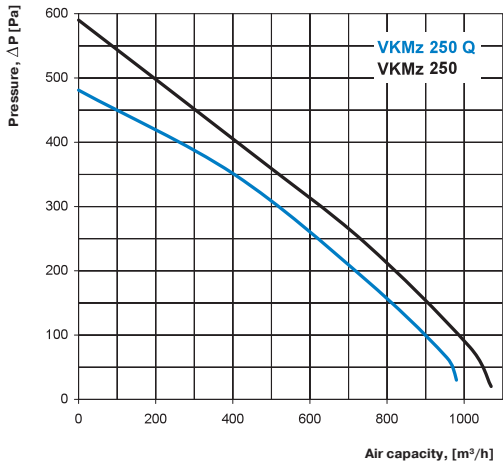

**VKMz 250 Q**

Sound-power level		Octave-frequency band [Hz]								
	Hz	Gen	63	125	250	500	1000	2000	4000	8000
$L_{WA}$ to inlet	dBA	69	46	59	61	65	62	58	60	54
$L_{WA}$ to outlet	dBA	74	49	59	63	66	67	62	64	56
$L_{WA}$ to environment	dBA	60	42	54	54	44	37	37	52	45

VKMz 250		Octave-frequency band [Hz]								
	Hz	Gen	63	125	250	500	1000	2000	4000	8000
$L_{WA}$ to inlet	dBA	75	60	66	67	67	67	63	56	45
$L_{WA}$ to outlet	dBA	76	60	73	71	69	65	66	59	46
$L_{WA}$ to environment	dBA	65	58	62	60	47	43	40	47	36

**VENTS VKMZ**

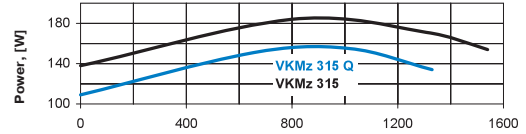
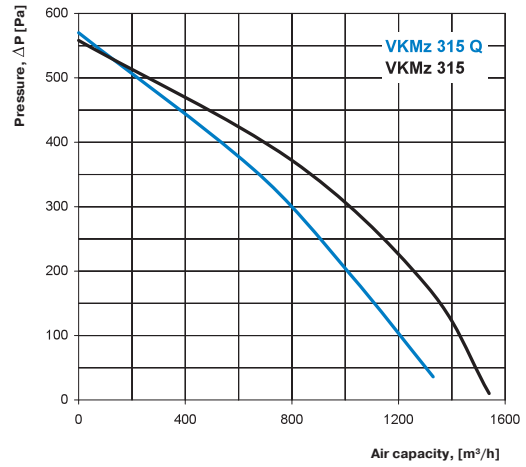

**VKMz 315 Q**

Sound-power level		Octave-frequency band [Hz]								
	Hz	Gen	63	125	250	500	1000	2000	4000	8000
$L_{WA}$ to inlet	dBA	70	35	53	61	65	67	61	58	56
$L_{WA}$ to outlet	dBA	74	41	54	64	73	70	65	62	60
$L_{WA}$ to environment	dBA	59	35	49	53	50	46	51	50	50

VKMz 315		Octave-frequency band [Hz]								
	Hz	Gen	63	125	250	500	1000	2000	4000	8000
$L_{WA}$ to inlet	dBA	77	53	66	71	69	68	66	63	60
$L_{WA}$ to outlet	dBA	78	58	71	74	72	71	71	63	63
$L_{WA}$ to environment	dBA	70	55	66	61	57	48	54	56	51



Series  
**VENTS VC**



In-line centrifugal duct fans with the air capacity up to **1880 m<sup>3</sup>/h**.

■ **Applications**

Supply and exhaust ventilation systems for various premises suitable for external surface mounting. For premises with high requirements to noise level, we offer units in low-noise modification (VC...Q).

■ **Design**

Fan casing is made of steel with polymeric coating. Various fan modifications for surface or flush mounting are available.

■ **Motor**

The plastic impeller with backward curved blades is powered by means of the single-phase motor with external rotor and overheating protection with automatic restart. For some dimension types high-powered motors are available (VC...S). Motor is equipped with ball bearings for longer service life designed for at least 40 000 hours. For precise features, safe operation and low noise, each turbine is dynamically balanced while assembly. Motor protection rating IP 44.

■ **Speed control**

Smooth or step speed control is performed with the thyristor or autotransformer controller. Several fans can be connected to one controller in case the total power and operating current do not exceed the controller rated values.

■ **Mounting**

Fan is designed for surface wall mounting (VC...PN and VC...VN models) or through-the-wall mounting (VC...PK and VC...VK) depending on design modification (see below). The fan is mounted to the wall with the mounting plate. The fan is powered through the external terminal box. Electric connection and installation shall be performed in compliance with the manual and wiring diagram on the terminal box.

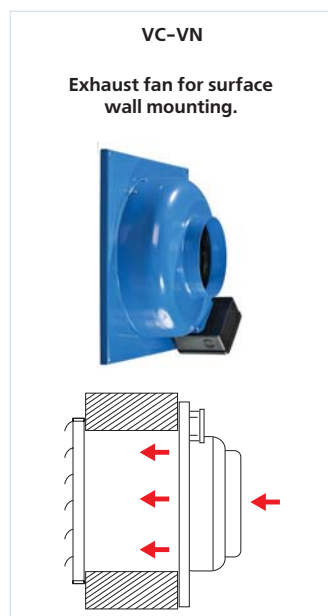
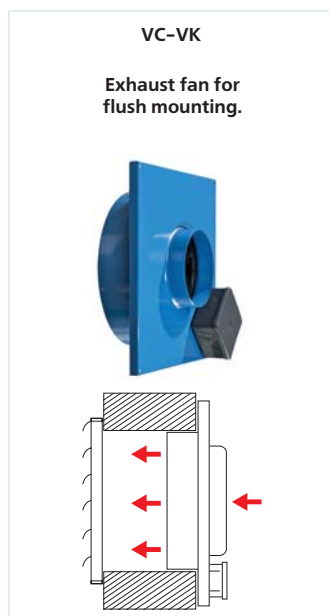
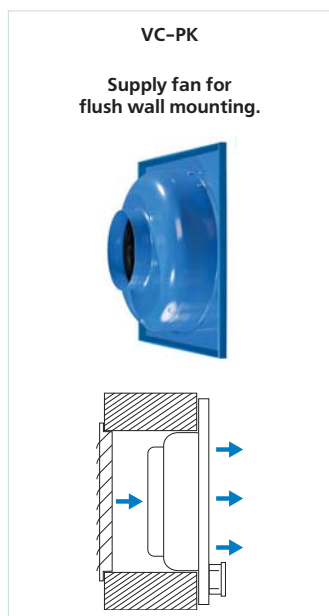

**Designation key:**

Fan series	*Option	Modification	Mounting options	Flange diameter	Additional options
<b>VENTS VC</b>	<b>S</b> – high-powered motor;	<b>V</b> - exhaust; <b>P</b> - supply	<b>N</b> - surface wall mounting; <b>K</b> - through-the-wall duct mounting	100; 125; 150; 160; 200; 250; 315	<b>Q</b> - low-noise application

**Accessories**



page 240    page 248    page 250    page 254    page 262    page 294    page 296    page 310    page 310    page 311    page 314    page 315

**Technical data:**

	VC 100 Q	VC 100	VC 125 Q	VC 125	VC 150	VC 160
Voltage [V / 50 Hz]	230	230	230	230	230	230
Power [W]	60	73	60	75	98	98
Current [A]	0,37	0,32	0,37	0,33	0,43	0,43
Maximum air flow [m³/h]	210	270	255	355	555	555
RPM [min <sup>-1</sup> ]	2620	2830	2535	2800	2705	2660
Noise level at 3 m [dBA]	36	47	36	47	47	47
Maximum operating temperature [°C]	-25 +55	-25 +55	-25 +55	-25 +55	-25 +55	-25 +55
Protection rating	IP X4	IP X4	IP X4	IP X4	IP X4	IP X4

**Technical data:**

	VC 200	VCS 200	VC 250 Q	VC 250	VC 315	VCS 315
Voltage [V / 50 Hz]	230	230	230	230	230	230
Power [W]	154	193	158	194	171	296
Current [A]	0,67	0,84	0,69	0,85	0,77	1,34
Maximum air flow [m³/h]	950	1100	1190	1310	1400	1880
RPM [min <sup>-1</sup> ]	2375	2780	2315	2790	2600	2720
Noise level at 3 m [dBA]	48	51	52	52	52	54
Maximum operating temperature [°C]	-25 +50	-25 +45	-25 +50	-25 +50	-25 +50	-25 +45
Protection rating	IP X4	IP X4	IP X4	IP X4	IP X4	IP X4

**Fan overall dimensions:**

Type	Dimensions [mm]						Mass [kg]
	∅D	∅D1	∅d	H	H1	L	
VC 100 Q	98	249	6,1	310	295	115	3,1
VC 100	98	249	6,1	310	295	115	3,2
VC 125 Q	123	249	6,1	310	295	115	3,1
VC 125	123	249	6,1	310	295	115	3,2
VC 150	149	300	6,1	400	385	115	4,8
VC 160	159	300	6,1	400	385	115	4,9
VC 200	198	339	6,1	400	385	138	6,1
VCS 200	198	339	6,1	400	385	138	6,1
VC 250 Q	248	339	6,1	400	385	138	7,1
VC 250	248	339	6,1	400	385	138	7,2
VC 315	315	399	6,1	460	445	146	7,8
VCS 315	315	399	6,1	460	445	180	7,8

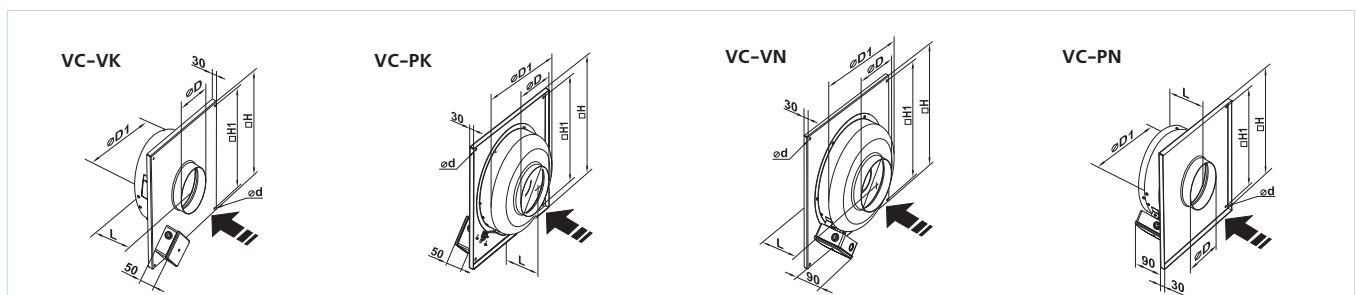

VENTS VC

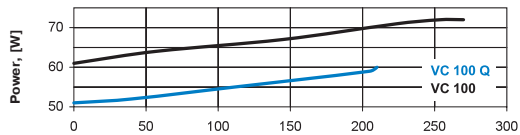
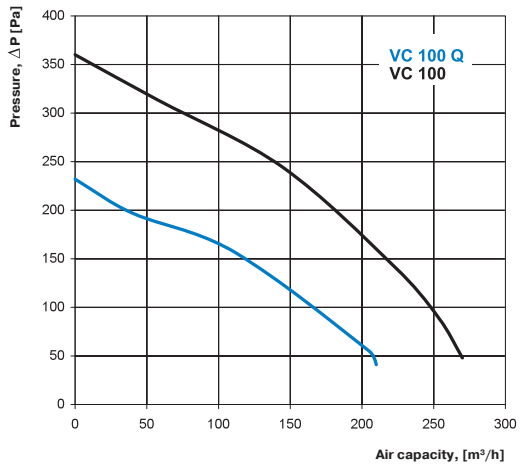

VC 100 Q

Sound-power level	Hz	Octave-frequency band [Hz]								
		Gen	63	125	250	500	1000	2000	4000	8000
L <sub>WA</sub> to inlet	dBA	62	52	60	56	60	48	48	41	28
L <sub>WA</sub> to outlet	dBA	67	49	57	58	60	54	52	45	30
L <sub>WA</sub> to environment	dBA	55	19	16	23	36	39	42	30	19

VC 100

Sound-power level	Hz	Octave-frequency band [Hz]								
		Gen	63	125	250	500	1000	2000	4000	8000
L <sub>WA</sub> to inlet	dBA	74	49	66	70	67	62	53	52	40
L <sub>WA</sub> to outlet	dBA	77	48	69	73	68	61	57	53	47
L <sub>WA</sub> to environment	dBA	63	43	63	57	40	27	6	20	25

VENTS VC

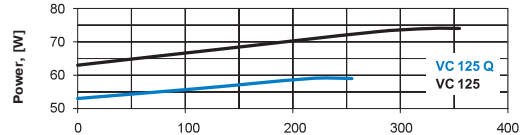
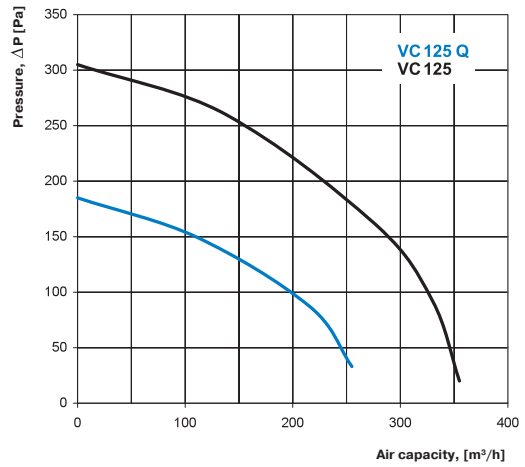

VC 125 Q

Sound-power level	Hz	Octave-frequency band [Hz]								
		Gen	63	125	250	500	1000	2000	4000	8000
L <sub>WA</sub> to inlet	dBA	61	32	53	55	55	49	45	36	30
L <sub>WA</sub> to outlet	dBA	58	37	54	57	54	52	50	36	34
L <sub>WA</sub> to environment	dBA	64	44	64	59	41	32	15	32	26

VC 125

Sound-power level	Hz	Octave-frequency band [Hz]								
		Gen	63	125	250	500	1000	2000	4000	8000
L <sub>WA</sub> to inlet	dBA	75	57	65	67	70	66	61	53	42
L <sub>WA</sub> to outlet	dBA	76	63	69	66	68	70	65	52	42
L <sub>WA</sub> to environment	dBA	65	54	60	59	46	36	21	29	25

VENTS VC

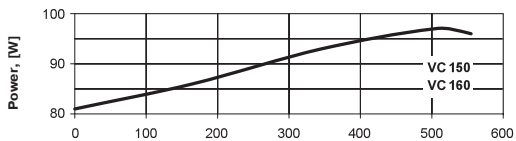
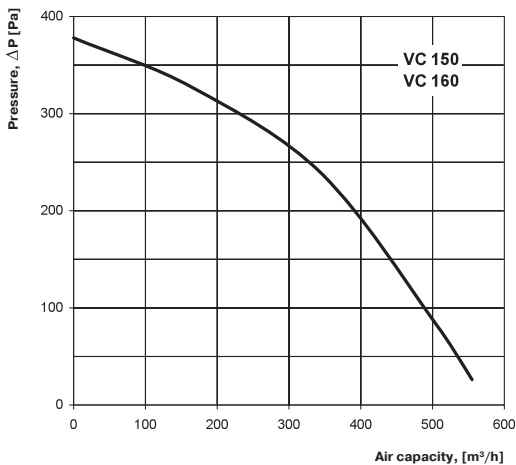

VC 150

Sound-power level	Hz	Octave-frequency band [Hz]								
		Gen	63	125	250	500	1000	2000	4000	8000
L <sub>WA</sub> to inlet	dBA	70	45	66	64	67	61	59	50	38
L <sub>WA</sub> to outlet	dBA	71	48	69	67	65	67	62	53	42
L <sub>WA</sub> to environment	dBA	62	39	62	54	39	19	17	28	20

VC 160

Sound-power level	Hz	Octave-frequency band [Hz]								
		Gen	63	125	250	500	1000	2000	4000	8000
L <sub>WA</sub> to inlet	dBA	72	44	64	64	63	61	59	48	35
L <sub>WA</sub> to outlet	dBA	72	43	66	68	66	65	63	50	42
L <sub>WA</sub> to environment	dBA	64	42	59	55	36	18	15	30	22

VENTS VC

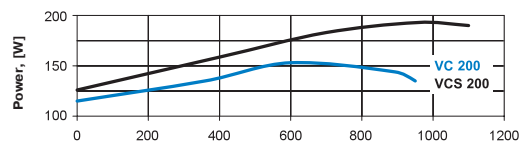
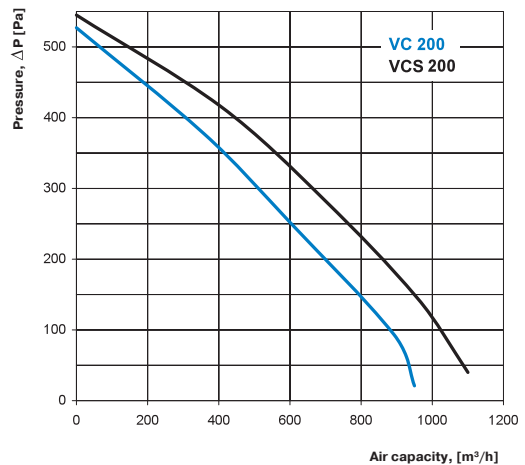

VC 200

Sound-power level	Hz	Octave-frequency band [Hz]								
		Gen	63	125	250	500	1000	2000	4000	8000
L <sub>WA</sub> to inlet	dBA	77	47	68	67	72	67	59	59	50
L <sub>WA</sub> to outlet	dBA	76	53	69	71	73	69	67	62	52
L <sub>WA</sub> to environment	dBA	64	46	61	57	50	33	26	44	39

VCS 200

Sound-power level	Hz	Octave-frequency band [Hz]								
		Gen	63	125	250	500	1000	2000	4000	8000
L <sub>WA</sub> to inlet	dBA	73	47	70	72	71	64	63	58	51
L <sub>WA</sub> to outlet	dBA	80	52	70	75	72	64	64	62	54
L <sub>WA</sub> to environment	dBA	64	49	66	61	47	33	29	45	42

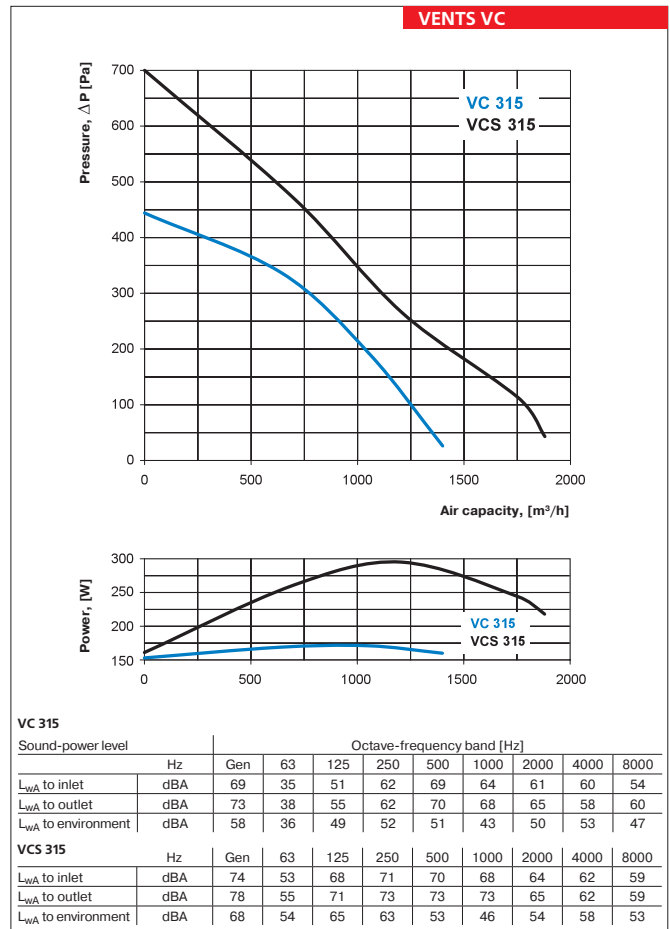
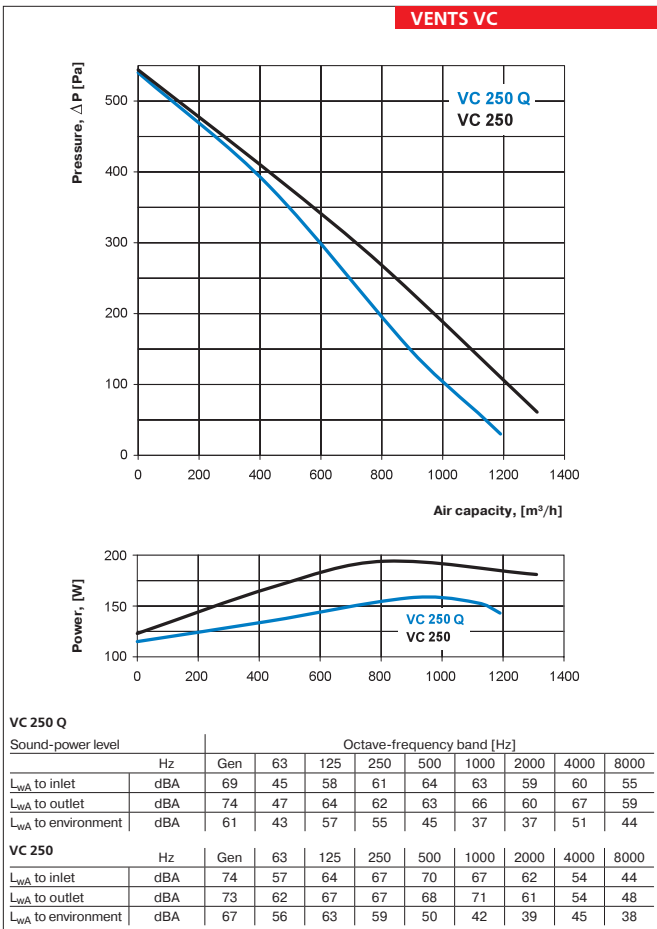



Series  
**VENTS VCN**



Exhaust centrifugal fans in steel casing with the air capacity up to **710 m<sup>3</sup>/h** for outdoor surface mounting.

■ **Applications**

Exhaust ventilation system for various premises designed for air exhaust with the temperature up to 55°C. Direct air exhaust is provided.

■ **Design**

Steel casing with polymeric coating ensures motor protection against direct humidity exposure in case of the unit outdoor mounting. The fan bottom has a bird and rodent proof guard. Air is exhausted vertically down.

■ **Motor**

The centrifugal impeller with backward curved blades is powered by the single-phase motor with external rotor and overheating protection with automatic restart. The motor is equipped with ball bearings for long service life designed for at least 40 000 hours. For precise features, safe operation and low noise, each turbine is dynamically balanced while assembly. Motor protection rating IP 44.

■ **Speed control**

Smooth or step speed control is performed with the thyristor or autotransformer controller. Several fans can be connected to one controller in case their total power and operating current do not exceed the rated controller values.

■ **Mounting**

The fan is designed for outdoor surface wall mounting and connection to round duct of the respective diameter. The fan is powered through the external terminals. Electric connection and mounting shall be performed in compliance with the manual and wiring diagram provided in unit operation manual.



The motor is protected against direct water drops and solid objects.



VCN fan WC ventilation example.

Designation key: \_\_\_\_\_

Fan series
<b>VENTS VCN</b>

Flange diameter
100; 125; 150; 160; 200

Accessories



page 240    page 294    page 295    page 296    page 305    page 310    page 310    page 311    page 311    page 314    page 315

**Technical data:**

	VCN 100	VCN 125	VCN 150	VCN 160	VCN 200
Voltage [V / 50 Hz]	230	230	230	230	230
Power [W]	58	60	100	102	104
Current [A]	0,26	0,27	0,43	0,44	0,45
Maximum air flow [m³/h]	280	390	600	650	710
RPM [min <sup>-1</sup> ]	2500	2500	2600	2600	2600
Noise level at 3 m [dBA]	54	54	58	60	62
Maximum operating temperature [°C]	55	55	55	55	55
Protection rating	IP X4	IP X4	IP X4	IP X4	IP X4

**Fan overall dimensions:**

Type	Dimensions [mm]				Mass [kg]
	∅D	B	H	L	
VCN 100	99	260	355	138	4,1
VCN 125	124	260	355	138	4,1
VCN 150	149	300	400	138,2	4,5
VCN 160	159	300	400	138,2	4,5
VCN 200	199	300	400	138,2	4,5

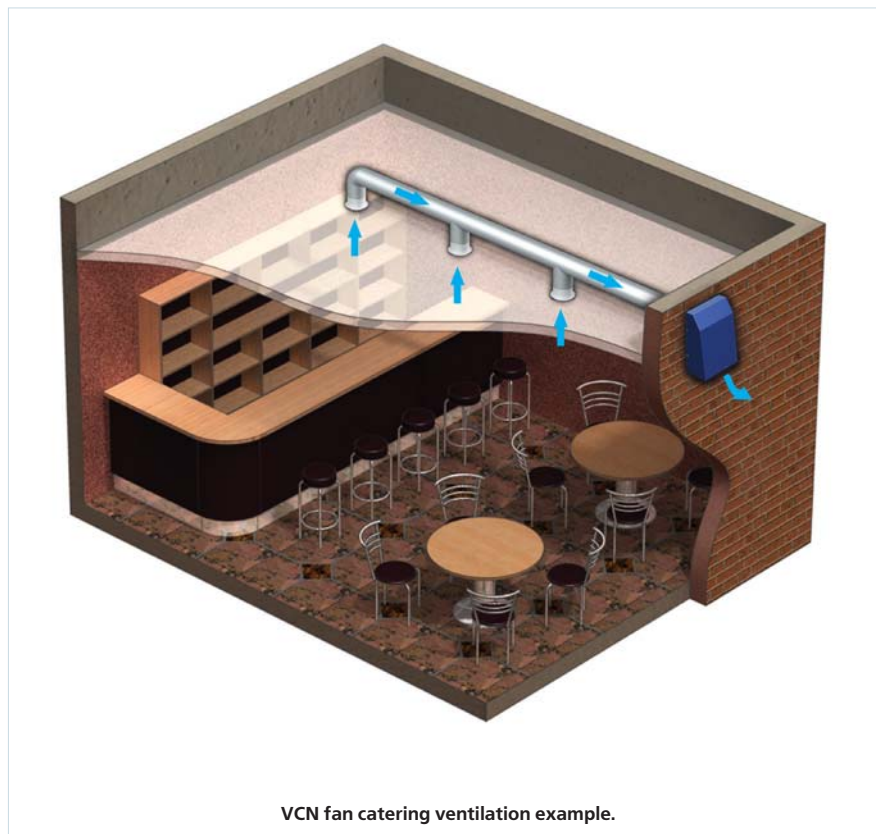
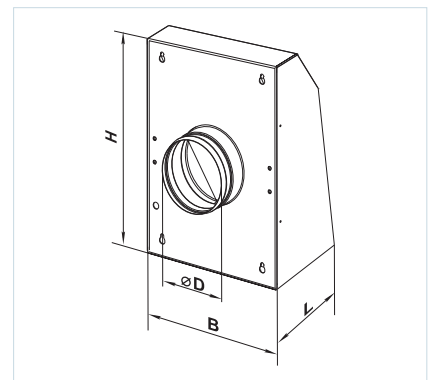

FAN SERIES VENTS VCN

VENTS VCN

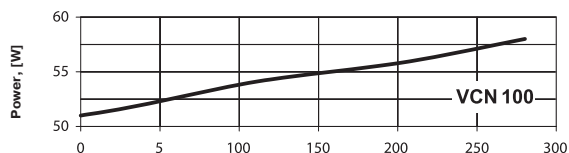
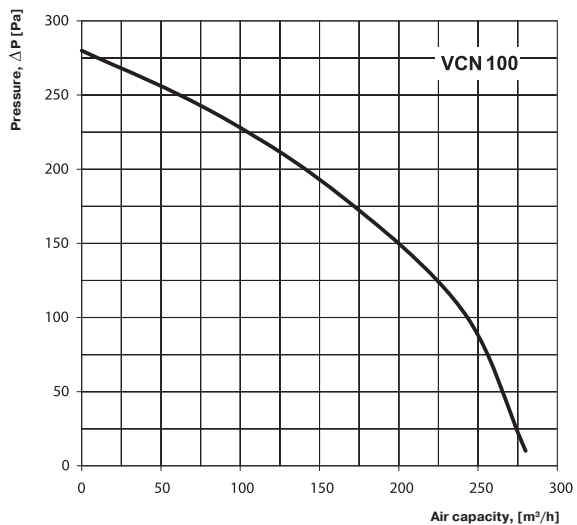

Sound-power level	Octave-frequency band [Hz]									
	Hz	Gen	63	125	250	500	1000	2000	4000	8000
$L_{WA}$ to inlet	dBA	60	46	52	58	58	58	51	40	28
$L_{WA}$ to environment	dBA	58	39	40	49	55	60	56	43	35

VENTS VCN

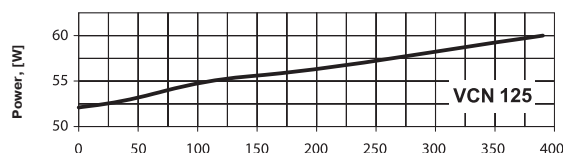
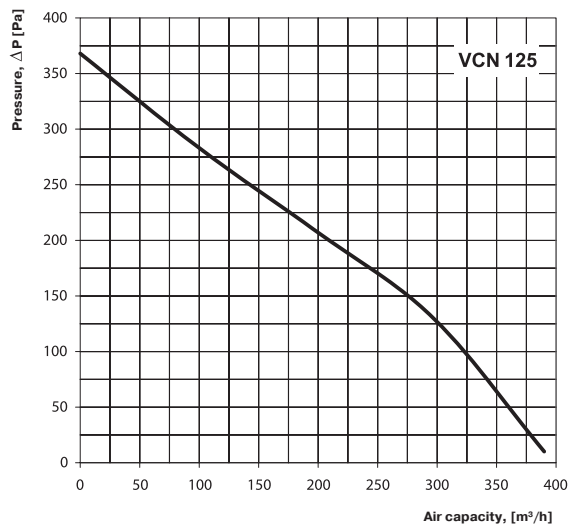

Sound-power level	Octave-frequency band [Hz]									
	Hz	Gen	63	125	250	500	1000	2000	4000	8000
$L_{WA}$ to inlet	dBA	58	48	54	59	56	57	52	42	29
$L_{WA}$ to environment	dBA	59	41	41	52	55	58	54	46	35

VENTS VCN

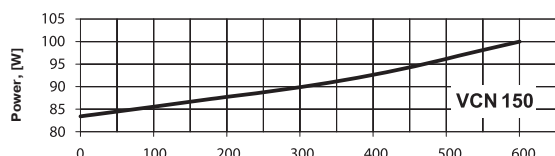
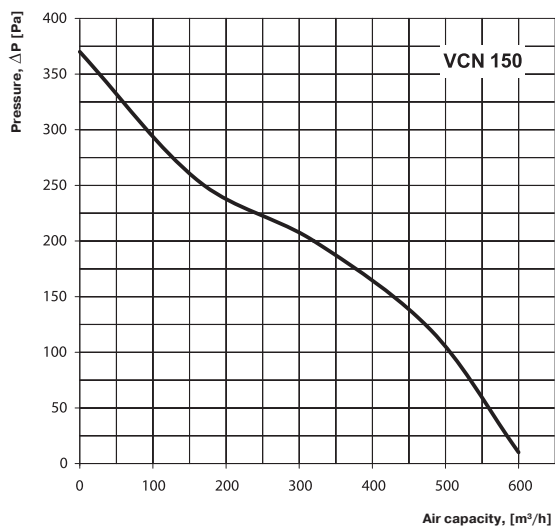

Sound-power level	Octave-frequency band [Hz]									
	Hz	Gen	63	125	250	500	1000	2000	4000	8000
$L_{WA}$ to inlet	dBA	57	45	53	54	57	56	46	38	19
$L_{WA}$ to environment	dBA	56	48	38	48	52	54	49	39	32

VENTS VCN

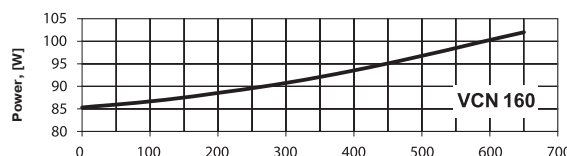
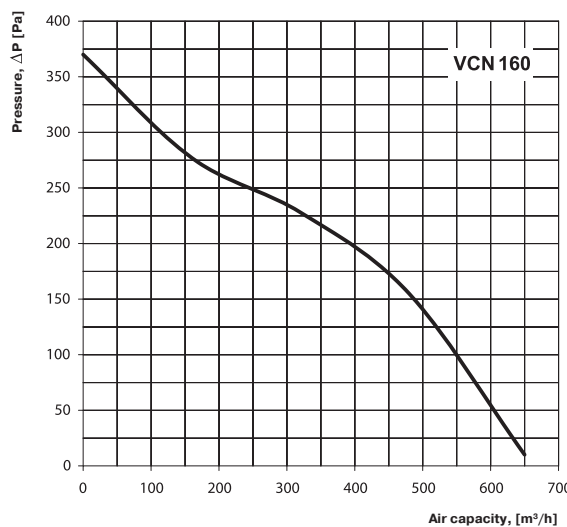

Sound-power level	Octave-frequency band [Hz]									
	Hz	Gen	63	125	250	500	1000	2000	4000	8000
$L_{WA}$ to inlet	dBA	55	44	54	55	58	54	46	36	18
$L_{WA}$ to environment	dBA	54	46	39	49	51	53	49	42	31

**VENTS VCN**

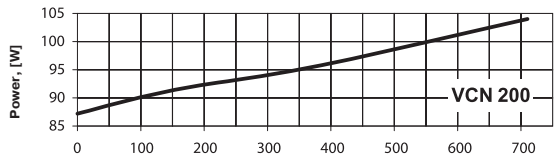
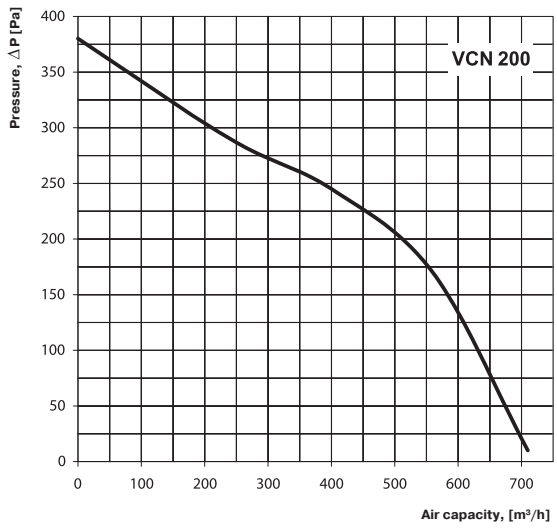

Sound-power level	Hz	Gen	Octave-frequency band [Hz]							
			63	125	250	500	1000	2000	4000	8000
$L_{WA}$ to inlet	dBA	59	48	55	50	58	58	48	41	23
$L_{WA}$ to environment	dBA	55	47	39	51	55	53	52	38	33

Series  
**VENTS VKP**

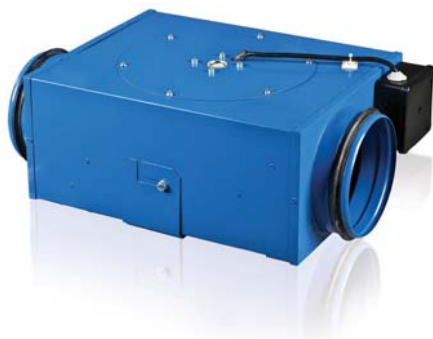

Centrifugal fans in the steel casing with the air capacity up to **553 m<sup>3</sup>/h** for round ducts

■ **Applications**

Supply and exhaust ventilation systems for various premises with the limited mounting space. Suitable for connection with Ø 100 and up to 160 mm round ducts.

■ **Design**

The fan casing is made of steel with polymeric coating. The removable cover provides easy access to the motor, thus ensuring easy mounting as well as the fan and the air ducts maintenance without dismounting.

■ **Motor**

The centrifugal impeller with backward curved blades is powered by means of the single-phase motor with external rotor and overheating protection with automatic restart. The motor is equipped with ball bearings for long service life designed for at least

40 000 hours. For precise features, safe operation and low noise, each turbine is dynamically balanced while assembly. Motor protection rating IP 44.

■ **Speed control**

Smooth or step speed control is performed with the thyristor or autotransformer controller. Several fans can be connected to one controller in case the total power and operating current do not exceed the rated controller values.

■ **Mounting**

Mounting at any angle to wall is performed with fastening bracket supplied with the unit. The fan is powered through the external terminal box. Electric supply and mounting shall be performed in compliance with the manual and wiring diagram on the terminal box.



External terminal box for power supply



Easy access to motor without fan dismounting.

**Technical data:**

	VKP 100	VKP 125	VKP 150	VKP 160
Voltage [V / 50 Hz]	230	230	230	230
Power [W]	58	58	85	85
Current [A]	0,26	0,26	0,38	0,38
Maximum air flow [m <sup>3</sup> /h]	240	340	553	553
RPM [min <sup>-1</sup> ]	2500	2500	2600	2600
Noise level at 3 m [dBA]	47	48	50	50
Maximum operating temperature [°C]	-25 +50	-25 +50	-25 +40	-25 +40
Protection rating	IP X4	IP X4	IP X4	IP X4

**Designation key:**

Fan series	Flange diameter
<b>VENTS VKP</b>	100; 125; 150; 160

**Accessories**



page 240

page 248

page 250

page 254

page 262

page 294

page 296

page 310

page 310

page 311

page 314

page 315



**Fan overall dimensions:**

Type	Dimensions [mm]					Mass [kg]
	∅D	B	H	L	L2	
VKP 100	99	260	110	352	253	3,2
VKP 125	124	255	145	420	322	4,5
VKP 150	149	305	175	480	382	5,4
VKP 160	159	305	175	480	382	5,5

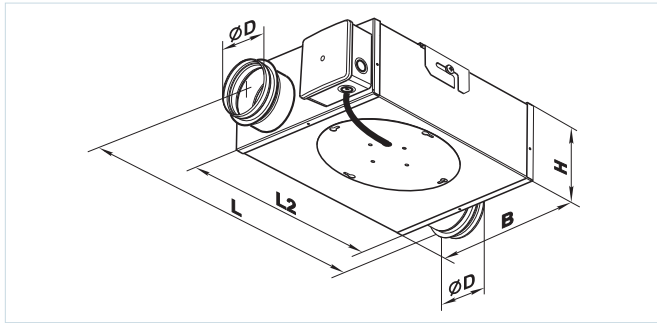

VKP fan office ventilation example

FAN SERIES VENTS VKP

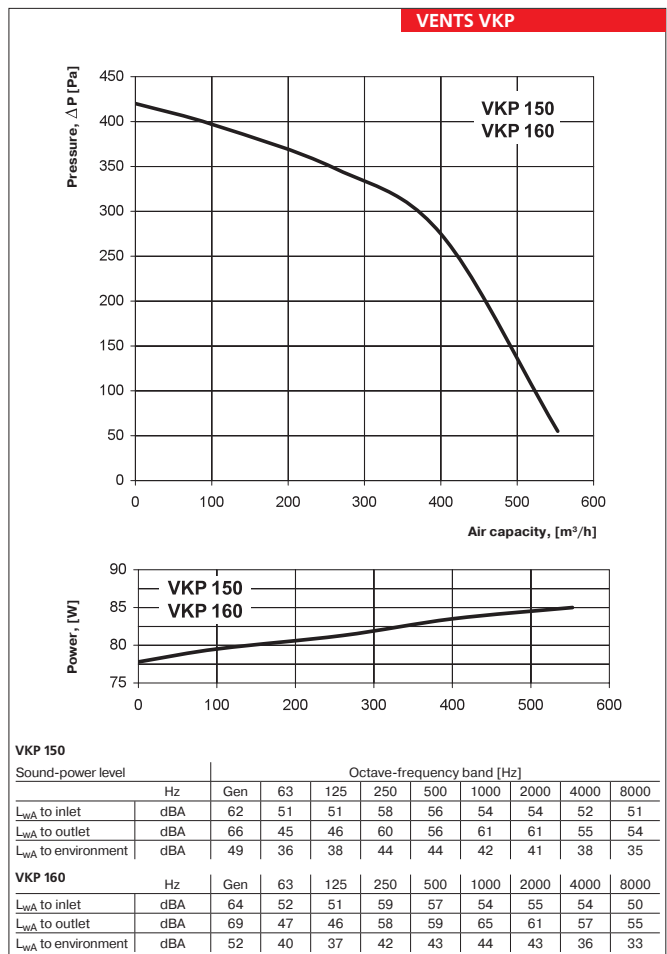
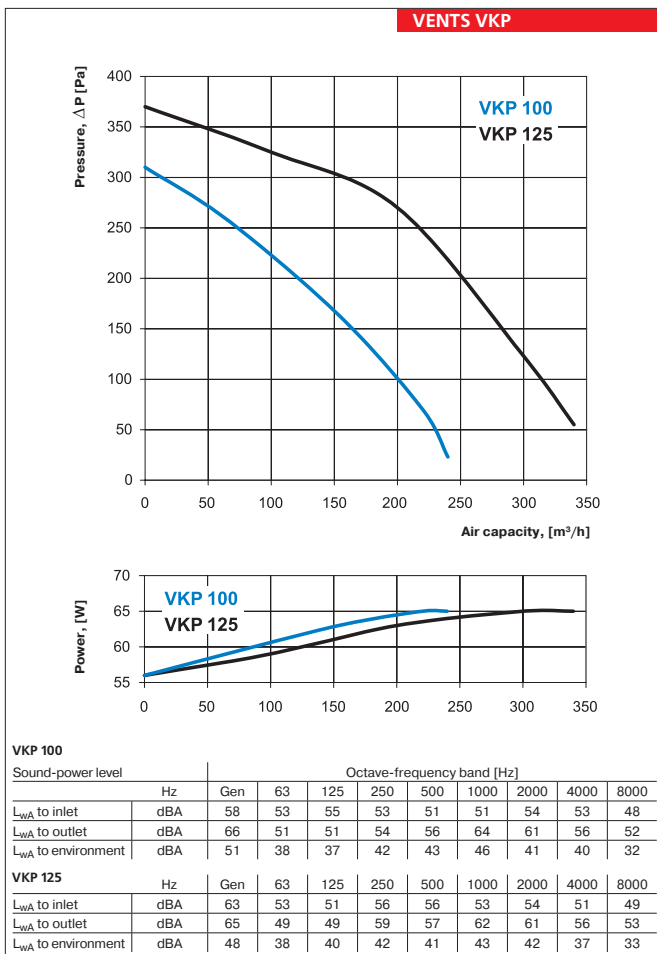

Series  
**VENTS VKP mini**



Compact centrifugal fans in steel casing with the air capacity up to **176 m<sup>3</sup>/h** with permanent airflow maintaining at alternating pressure in the system.

■ **Applications**

Supply and exhaust ventilation systems for various small premises with a limited mounting space. For connection with Ø 80 and 100 mm round ducts. Various casing modifications with the number of inlets from 1 to 6 enable using one fan for air exhaust from several premises simultaneously. This makes ventilation system mounting much easier.

■ **Design**

The fan casing is made of steel with polymeric coating. The casing height is only 94 mm for VKP..80 model and 112 mm for VKP..100 model that enables fan mounting in a limited space. The removable cover provides free access to the motor, ensures easy mounting and enables the fan and air ducts maintenance without dismounting.

■ **Motor**

The centrifugal impeller with backward curved blades for high pressure is powered by means of the single-phase three-speed motor with external rotor. The custom designed «SMART» turbine construction (motor and impeller) provides constant airflow support in the premise and simultaneous motor speed control as a function of air resistance in the duct. Motor is equipped with incorporated overheating

protection with automatic restart and ball bearings for long service life designed for at least 40 000 hours. For precise features, safe operation and low noise, each turbine is dynamically balanced while assembly. Motor protection rating IP 44.

■ **Speed control**

The motor speed changes automatically as a function of ventilation system resistance thus ensuring the constant air flow. For smooth or step speed control a thyristor or autotransformer controller can be applied. Motor speed changes automatically as a function of the ventilation system resistance. This ensures constant airflow. If a three-position switch is additionally installed, three speeds of motor can be controlled manually.

Several fans can be connected to one controller in case the total power and operating current do not exceed the controller rated values.

■ **Mounting**

Mounting at any angle to the wall is performed with the fastening bracket supplied with the unit. The fan is powered through the external terminal box. Electric connection and mounting shall be performed in compliance with the manual and wiring diagram on the terminal box.

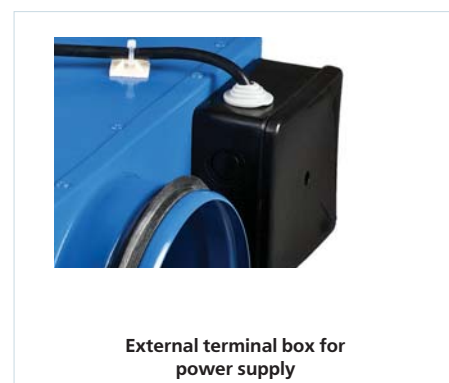

**Designation key:** \_\_\_\_\_

Series	Flange diameter	Flange number	Type
<b>VENTS VKP</b>	80; 100	1 / 2 / 4 / 6	<b>mini</b>

**Accessories** \_\_\_\_\_



page 294    page 296    page 305    page 320    page 322    page 323

VKP mini fan modifications

VENTS  
VKP mini  
FAN SERIES

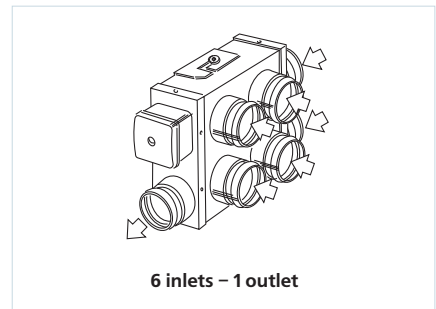
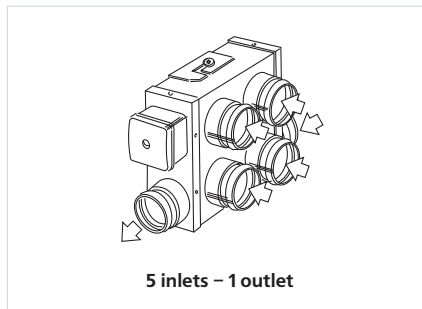
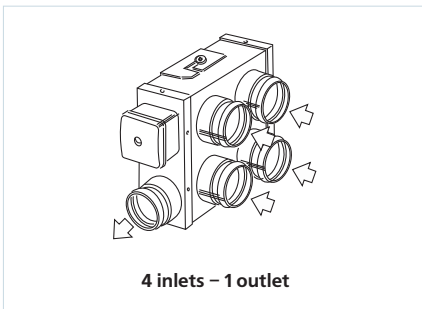
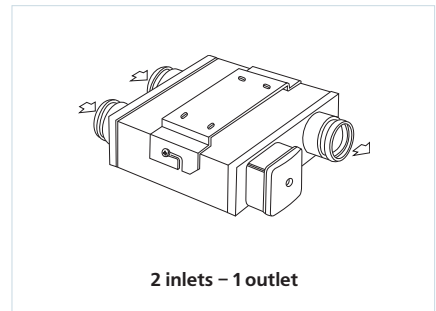
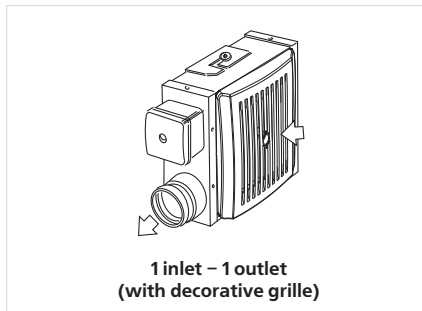
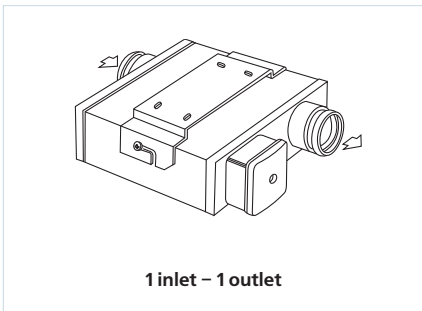

Technical data:

	VKP 80 mini			VKP 100 mini		
Speed	1	2	3	1	2	3
Voltage [V / 50 Hz]	230	230	230	230	230	230
Power [W]	20	26	45	20	26	45
Current [A]	0,32	0,34	0,4	0,32	0,34	0,4
Maximum air flow [m <sup>3</sup> /h]	88	130	162	97	138	176
RPM [min <sup>-1</sup> ]	1400	1800	2600	1400	1800	2600
Noise level at 3 m [dBA]	32	35	43	33	36	44
Maximum operating temperature [°C]	50	50	50	50	50	50
Protection rating	IP X4	IP X4	IP X4	IP X4	IP X4	IP X4

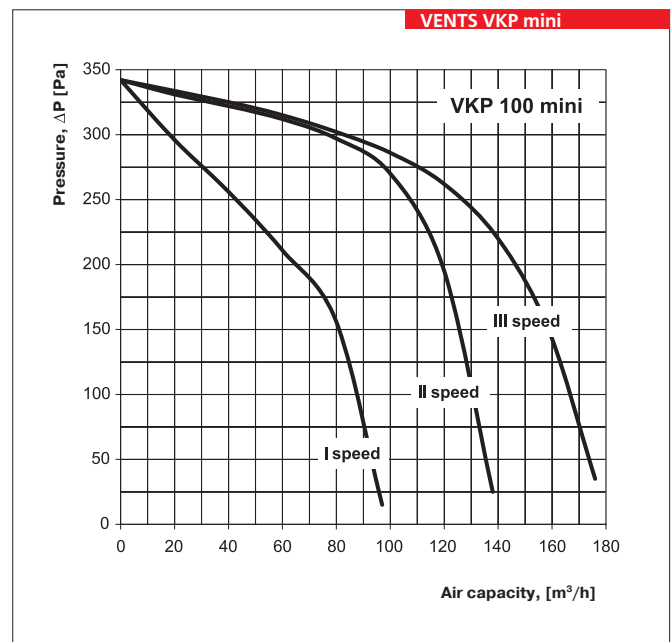
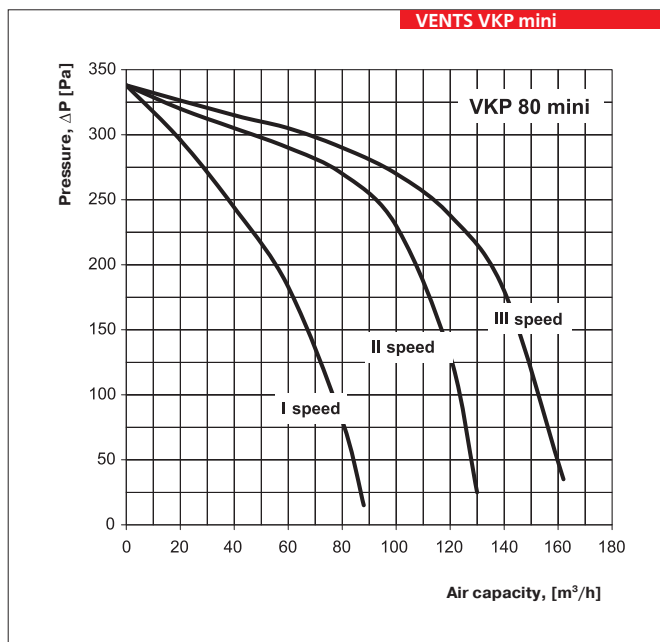

## Fan overall dimensions:

Type	Dimensions [mm]								Mass [kg]	Figure no.
	∅D	∅D1	B	H	H1	L	L1	L2		
VKP 80 mini	79	79	260	90	-	352	-	253	3,2	3
VKP 100 mini	99	99	260	110	-	352	-	253	3,2	3
VKP 80 R mini	79	-	260	90	126	-	302	253	3,1	1
VKP 100 R mini	99	-	260	110	146	-	302	253	3,1	1
VKP 80/80*2 mini	79	79	260	90	-	352	-	253	3,1	5
VKP 100/100*2 mini	99	99	260	110	-	352	-	253	3,1	5
VKP 80/80*4 mini	79	79	260	90	150	-	302	253	3,4	2
VKP 100/100*4 mini	99	99	260	110	170	-	302	253	3,4	2
VKP 100/80*2 mini	99	79	260	110	-	352	-	253	3,1	5
VKP 100/80*4 mini	99	79	260	110	170	-	302	253	3,1	2
VKP 80/80*5 mini	79	79	260	90	150	352	-	253	3,5	4
VKP 80/80*6 mini	79	79	260	90	150	352	-	253	3,6	6
VKP 100/80*6 mini	99	79	260	110	150	352	-	253	3,6	6
VKP 100/80*5 mini	99	79	260	110	170	352	-	253	3,7	4
VKP 100/100*5 mini	99	99	260	110	170	352	-	253	3,5	4
VKP 100/100*6 mini	99	99	260	110	170	352	-	253	3,5	6

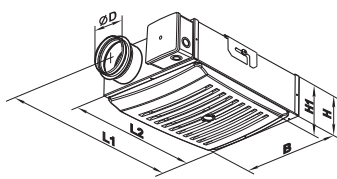

Fig. 1

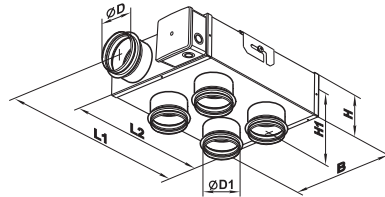

Fig. 2

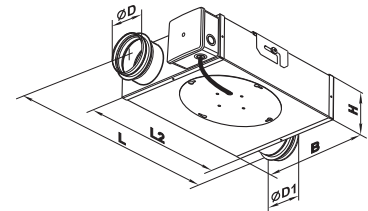

Fig. 3

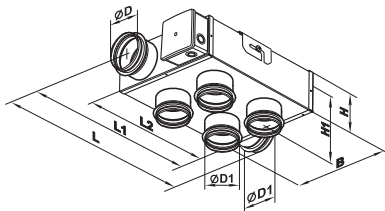

Fig. 4

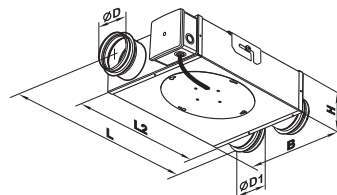

Fig. 5

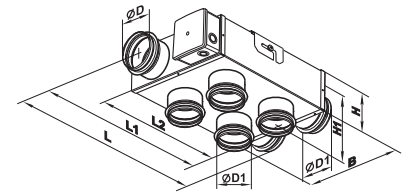

Fig. 6

■ VKP mini ventilation examples

▶ 1 inlet – 1 outlet



▶ 2 inlets – 1 outlet



▶ 4 inlets – 1 outlet

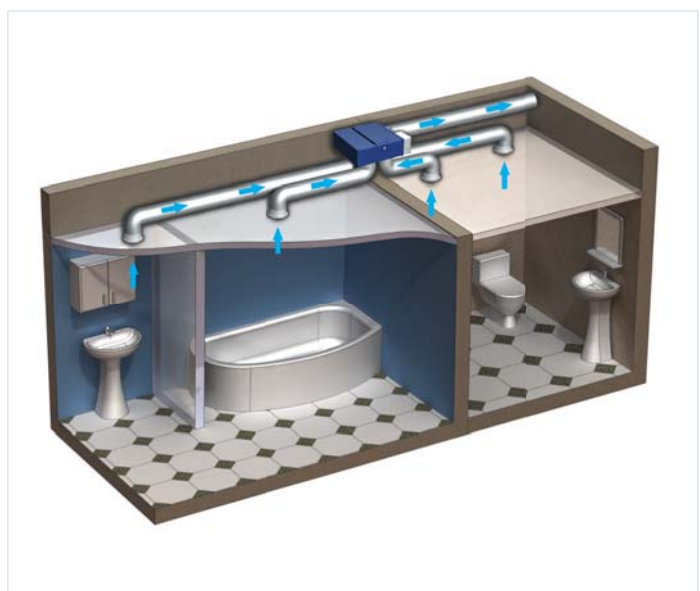







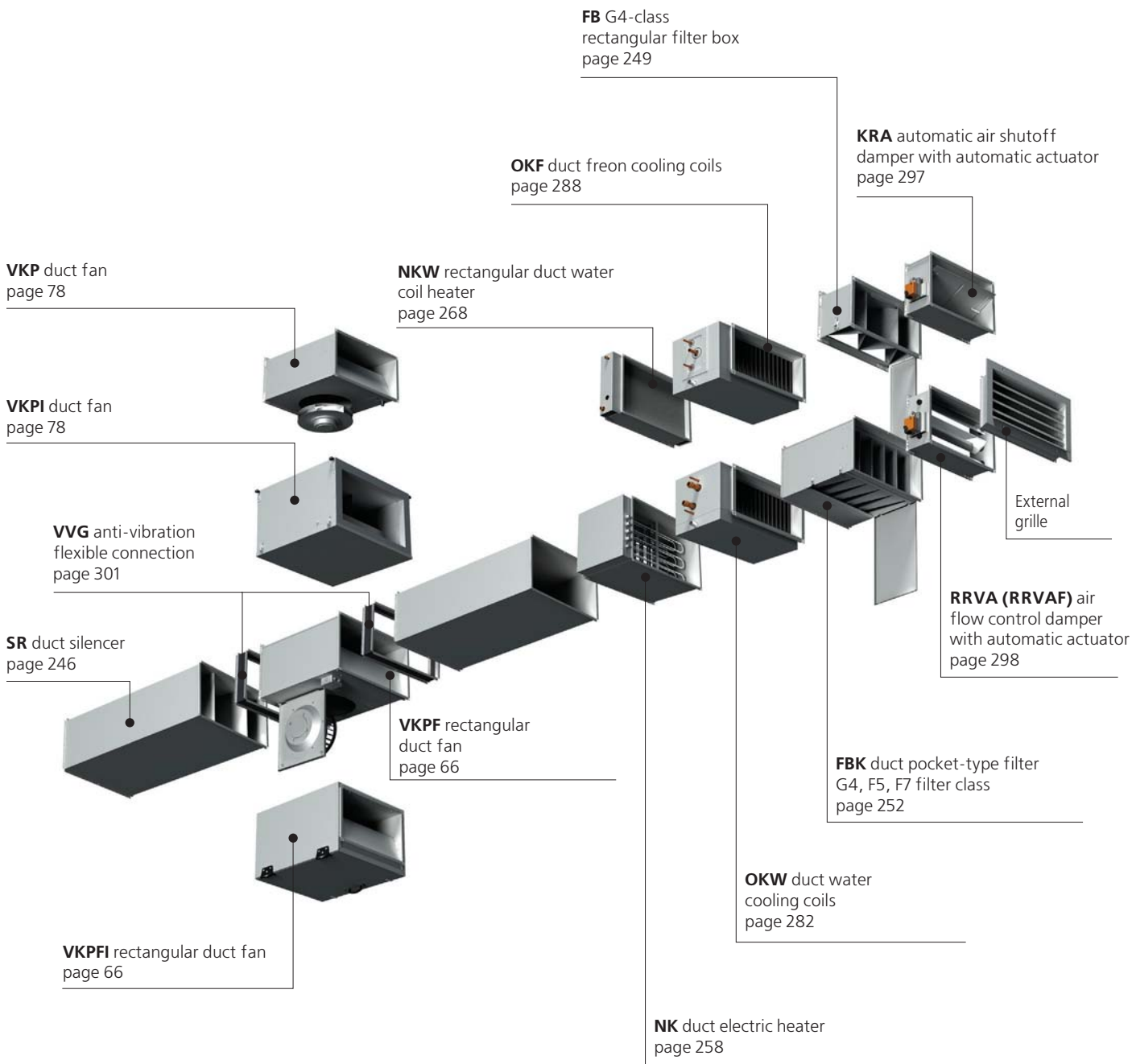

**SELECTION TABLE FOR RECTANGULAR ITEMS**

	400x200	500x250	500x300	600x300	600x350	700x400	800x500	900x500	1000x500
<b>Fans</b>	VKPF 4E 400x200	VKPF 4E 500x250	VKPF 4E 500x300	VKPF 4E 600x300	VKPF 4E 600x350	VKPF 4D 700x400	VKPF 6D 800x500	VKPF 6D 900x500	VKPF 6D 1000x500
	VKPF 4D 400x200	VKPF 4D 500x250	VKPF 4D 500x300	VKPF 4D 600x300	VKPF 4D 600x350		VKPF 4D 800x500		
	VKPI 4E 400x200	VKPI 4E 500x250	VKPI 4E 500x300	VKPI 4E 600x300	VKPI 4E 600x350	VKPI 4D 700x400	VKPI 6D 800x500	VKPI 6D 900x500	VKPI 6D 1000x500
	VKPI 4D 400x200	VKPI 4D 500x250	VKPI 4D 500x300	VKPI 4D 600x300	VKPI 4D 600x350		VKPI 4D 800x500		
				VKP 600x300 EC	VKP 600x350 EC	VKP 700x400 EC	VKP 800x500 EC		VKP 1000x500 EC
	VKP 2E 400x200	VKP 2E 500x250	VKP 4E 500x300	VKP 4E 600x300	VKP 4E 600x350				
			VKP 4D 500x300	VKP 4D 600x300	VKP 4D 600x350				
	VKPI 2E 400x200	VKPI 2E 500x250	VKPI 4E 500x300	VKPI 4E 600x300	VKPI 4E 600x350				
			VKPI 4D 500x300	VKPI 4D 600x300	VKPI 4D 600x350				
<b>Filters</b>	FB 400x200	FB 500x250	FB 500x300	FB 600x300	FB 600x350	FB 700x400	FB 800x500	FB 900x500	FB 1000x500
	FBK 400x200-4	FBK 500x250-4	FBK 500x300-4	FBK 600x300-4	FBK 600x350-4	FBK 700x400-4	FBK 800x500-4	FBK 900x500-4	FBK 1000x500-4
	FBK 400x200-5	FBK 500x250-5	FBK 500x300-5	FBK 600x300-5	FBK 600x350-5	FBK 700x400-5	FBK 800x500-5	FBK 900x500-5	FBK 1000x500-5
	FBK 400x200-7	FBK 500x250-7	FBK 500x300-7	FBK 600x300-7	FBK 600x350-7	FBK 700x400-7	FBK 800x500-7	FBK 900x500-7	FBK 1000x500-7
<b>Heaters</b>									
<b>electrical heaters</b>	NK 400x200-4,5-3	NK 500x250-6,0-3	NK 500x300-6,0-3	NK 600x300-9,0-3	NK 600x350-9,0-3	NK 700x400-18-3	NK 800x500-27-3	NK 900x500-45-3	NK 1000x500-45-3
	NK 400x200-6,0-3	NK 500x250-7,5-3	NK 500x300-7,5-3	NK 600x300-12,0-3	NK 600x350-12,0-3	NK 700x400-27-3	NK 800x500-36-3	NK 900x500-54-3	NK 1000x500-54-3
	NK 400x200-7,5-3	NK 500x250-9,0-3	NK 500x300-9,0-3	NK 600x300-15,0-3	NK 600x350-15,0-3	NK 700x400-36-3	NK 800x500-54-3		
	NK 400x200-9,0-3	NK 500x250-10,5-3	NK 500x300-10,5-3	NK 600x300-18,0-3	NK 600x350-18,0-3				
	NK 400x200-10,5-3	NK 500x250-12,0-3	NK 500x300-12,0-3	NK 600x300-21,0-3	NK 600x350-21,0-3				
	NK 400x200-12,0-3	NK 500x250-15,0-3	NK 500x300-15,0-3	NK 600x300-24,0-3	NK 600x350-24,0-3				
	NK 400x200-15,0-3	NK 500x250-18,0-3	NK 500x300-18,0-3						
		NK 500x250-21,0-3	NK 500x300-21,0-3						
<b>water coils</b>	NKW 400x200-2	NKW 500x250-2	NKW 500x300-2	NKW 600x300-2	NKW 600x350-2	NKW 700x400-2	NKW 800x500-2	NKW 900x500-2	NKW 1000x500-2
	NKW 400x200-4	NKW 500x250-4	NKW 500x300-4	NKW 600x300-4	NKW 600x350-4	NKW 700x400-3	NKW 800x500-3	NKW 900x500-3	NKW 1000x500-3
<b>Cooling coils</b>									
<b>water cooling coils</b>	OKW 400C200-3	OKW 500C250-3	OKW 500C300-3	OKW 600C300-3	OKW 600C350-3	OKW 700x400-3	OKW 800x500-3	OKW 900x500-3	OKW 1000x500-3
<b>freon cooling coils</b>	OKF 400C200-3	OKF 500C250-3	OKF 500C300-3	OKF 600C300-3	OKF 600C350-3	OKF 700x400-3	OKF 800x500-3	OKF 900x500-3	OKF 1000x500-3
<b>Silencers</b>	SR 400x200	SR 500x250	SR 500x300	SR 600x300	SR 600x350	SR 700x400	SR 800x500	SR 900x500	SR 1000x500
<b>Dampers and shutters</b>	KR 400x200	KR 500x250	KR 500x300	KR 600x300	KR 600x350				
	KRA 400x200	KRA 500x250	KRA 500x300	KRA 600x300	KRA 600x350				
	KOM1 400x200	KOM1 500x250	KOM1 500x300	KOM1 600x300	KOM1 600x350				
	RRV 400x200	RRV 500x250	RRV 500x300	RRV 600x300	RRV 600x350	RRV 700x400	RRV 800x500	RRV 900x500	RRV 1000x500
	RRVA 400x200	RRVA 500x250	RRVA 500x300	RRVA 600x300	RRVA 600x350	RRVA 700x400	RRVA 800x500	RRVA 900x500	RRVA 1000x500
	RRVAF 400x200	RRVAF 500x250	RRVAF 500x300	RRVAF 600x300	RRVAF 600x350	RRVAF 700x400	RRVAF 800x500	RRVAF 900x500	RRVAF 1000x500
	KG 400x200	KG 500x250	KG 500x300	KG 600x300	KG 600x350	KG 700x400	KG 800x500	KG 900x500	KG 1000x500
<b>Flexible connectors</b>	VVG 400x200	VVG 500x250	VVG 500x300	VVG 600x300	VVG 600x350	VVG 700x400	VVG 800x500	VVG 900x500	VVG 1000x500
<b>Plate heat exchangers</b>	PR 400x200	PR 500x250	PR 500x300	PR 600x300	PR 600x350	PR 700x400	PR 800x500	PR 900x500	PR 1000x500
<b>Mixing chambers</b>	SKRA 400x200	SKRA 500x250	SKRA 500x300	SKRA 600x300	SKRA 600x350	SKRA 700x400	SKRA 800x500		
<b>Speed controllers</b>									
<b>thyristor type</b>	RS series	RS series	RS series	RS series	RS series	RS series	RS series	RS series	RS series
<b>transformer type</b>	RSA series	RSA series	RSA series	RSA series	RSA series	RSA series	RSA series	RSA series	RSA series
<b>frequency type</b>	VFED series	VFED series	VFED series	VFED series	VFED series	VFED series	VFED series	VFED series	VFED series

# RECTANGULAR DUCT FANS

## ▶ VENTS VKPF and VKPFI Series



▶ In-line centrifugal fans with forward-curved blades and the air capacity up to 9540 m<sup>3</sup>/h designed for supply and exhaust ventilation systems. VKPFI models are sound- and heat-insulated. Compatible with 400x200, 500x250, 500x300, 600x300, 600x350, 700x400, 800x500, 900x500, 1000x500 mm rectangular air ducts.

## ▶ VENTS VKP...EC Series



▶ In-line centrifugal duct fans equipped with EC-motors and forward-curved blades with the air capacity up to 10850 m<sup>3</sup>/h. Designed for supply and exhaust ventilation and conditioning systems for various premises requiring cost-effective solution and controllable ventilation system. Compatible with 600x300, 600x350, 700x400, 800x500, 1000x500 mm rectangular air ducts.

## ▶ VENTS VKP and VKPI Series



▶ In-line centrifugal duct fans with forward-curved blades and the air capacity up to 2970 m<sup>3</sup>/h. Designed for supply and exhaust ventilation systems. VKPI models are sound- and heat-insulated. Compatible with 400x200, 500x250, 500x300, 600x300, 600x350 mm rectangular air ducts.





**VENTS VKPF**  
in-line centrifugal fan

Air capacity – up to 9540 m<sup>3</sup>/h

page  
66



**VENTS VKPFI**  
in-line sound- and heat-insulated centrifugal fan

Air capacity – up to 9540 m<sup>3</sup>/h

page  
66



**VENTS VKP EC**  
in-line centrifugal fan with EC-motor

Air capacity – up to 10850 m<sup>3</sup>/h

page  
74



**VENTS VKP**  
in-line centrifugal fan

Air capacity – up to 2970 m<sup>3</sup>/h

page  
78



**VENTS VKPI**  
in-line sound- and heat-insulated centrifugal fan

Air capacity – up to 2970 m<sup>3</sup>/h

page  
78

Series  
**VENTS VKPF**



in-line centrifugal fans with the air capacity up to **9540 m<sup>3</sup>/h** for rectangular ducts

Series  
**VENTS VKPFI**



in-line sound- and heat-insulated centrifugal fans with the air capacity up to **9540 m<sup>3</sup>/h** for rectangular ducts

■ **Applications**

Supply and exhaust ventilation systems for various premises with a limited mounting space. Designed for connection with 400x200, 500x250, 500x300, 600x300, 600x350, 700x400, 800x500, 900x500, 1000x500 mm rectangular air ducts.

■ **Design**

The fan casing is made of galvanized steel. VKPFI models are heat- and sound-insulated with 50 mm layer of mineral wool.

■ **Motor**

The impeller made of galvanized steel with forward curved blades is powered by means of 4- or

6-pole external rotor asynchronous motor. Such modification ensures high airflow capacity and relatively significant differential pressure. For thermal overheating protection the thermal contacts with leaded outside terminals are incorporated in the motor winding for connection with the external protection devices. The motor is equipped with the ball bearings for long service life. For precise features, safe operation and low noise, each impeller is dynamically balanced while assembly. Motor protection rating IP 44.

■ **Speed control**

Both smooth or step speed control is performed with thyristor or autotransformer controller. Several fans can be connected to one controller in case their

total power and operating current do not exceed the controller rated values.

■ **Mounting**

The fans are designed for in-line rectangular air duct mounting and require no special fixing in case of direct connection. In case of connection through the flexible connectors the fan is fixed to a building by means of supports, suspension brackets or fixation brackets. The fans can be mounted in any position with respect to the pointer direction on the casing. Access for the fan maintenance shall be provided. The fan is powered through the external terminals. The casing is provided with the removable access door for maintenance.

**Designation key:** \_\_\_\_\_

Fan series		Motor modification		Flange diameter [WxH]	
<b>VENTS VKPF</b>	I – modification with sound-insulated casing	Number of poles		Phase	
		4	E – single phase	400x200, 500x250, 500x300, 600x300, 600x350, 700x400, 800x500, 900x500, 1000x500	
		6	D – three phases		

**Accessories**



page 238    page 246    page 249    page 252    page 258    page 268    page 298    page 300    page 301    page 302    page 314    page 315

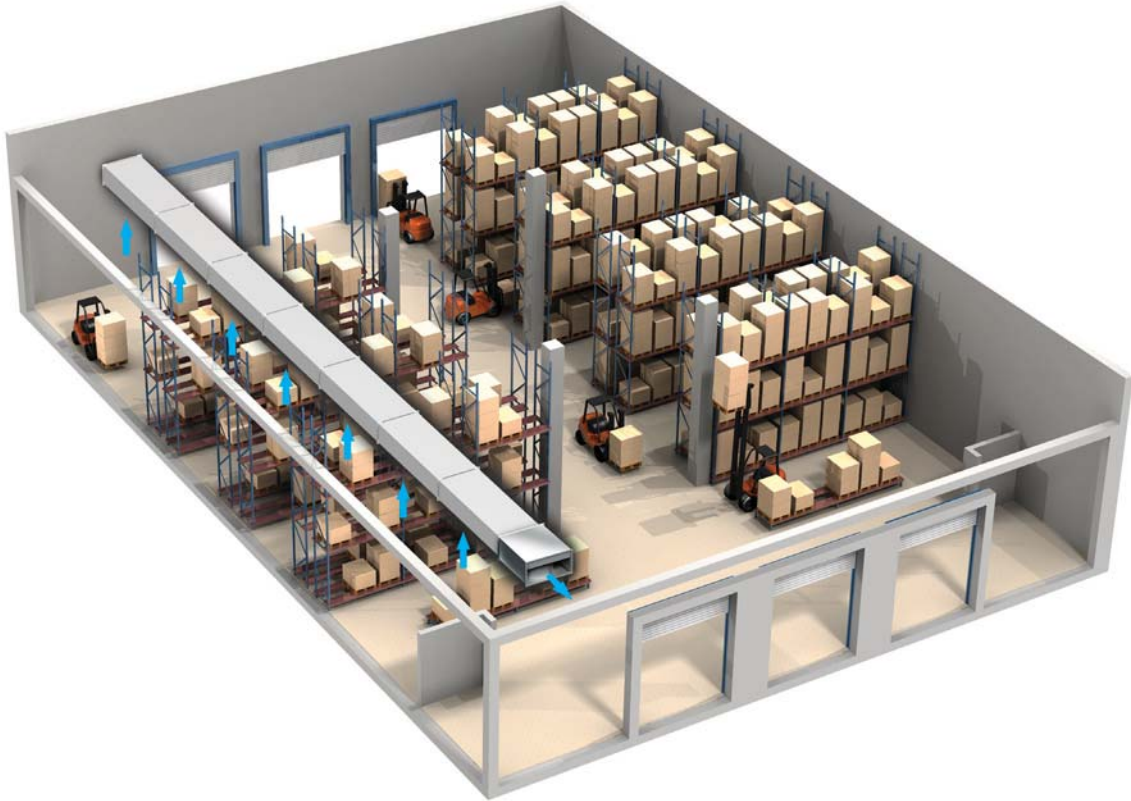

VKPF fan warehouse ventilation example

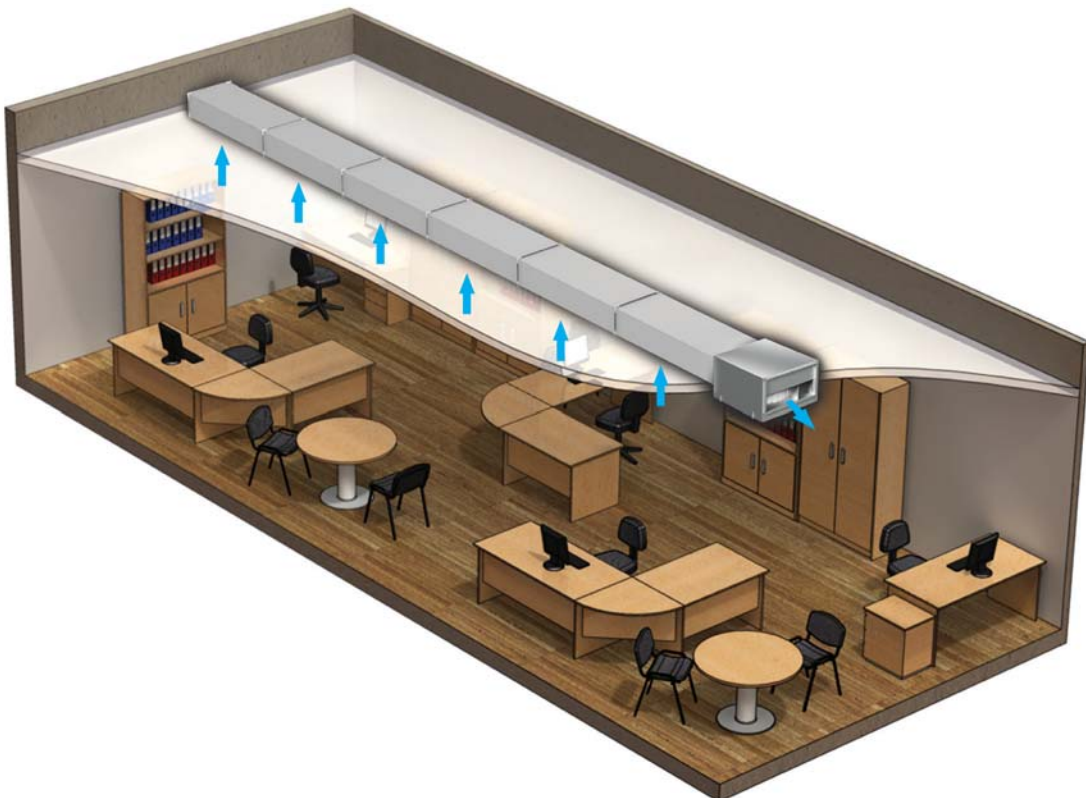

VKPFI fan office ventilation example

## RECTANGULAR DUCT FANS

### Technical data:

	VKPF / VKPFI 4E 400x200	VKPF / VKPFI 4D 400x200	VKPF / VKPFI 4E 500x250	VKPF / VKPFI 4D 500x250
Voltage [V / 50 Hz]	230	400	230	400
Power [W]	295	282	535	570
Current [A]	1,32	0,60	2,49	0,94
Maximum air flow [m <sup>3</sup> /h]	1440	1470	1750	1850
RPM [min <sup>-1</sup> ]	1350	1300	1250	1270
Noise level at 3 m [dBA]	50 / 42*	52 / 43*	53 / 44*	54 / 44*
Maximum operating temperature [°C]	-25 +40	-25 +45	-20 +40	-20 +40
Protection rating	IP X4	IP X4	IP X4	IP X4

\* parameter for VKPFI model

### Technical data:

	VKPF / VKPFI 4E 500x300	VKPF / VKPFI 4D 500x300	VKPF / VKPFI 4E 600x300	VKPF / VKPFI 4D 600x300
Voltage [V / 50 Hz]	230	400	230	400
Power [W]	710	855	1240	1560
Current [A]	3,10	1,70	6,45	2,73
Maximum air flow [m <sup>3</sup> /h]	2350	2350	2950	3740
RPM [min <sup>-1</sup> ]	1230	1300	1210	1310
Noise level at 3 m [dBA]	57 / 47*	56 / 47*	59 / 51*	57 / 50*
Maximum operating temperature [°C]	-25 +70	-20 +50	-25 +50	-25 +65
Protection rating	IP X4	IP X4	IP X4	IP X4

\* parameter for VKPFI model

### Fan overall dimensions:

Type	Dimensions [mm]								Mass [kg]
	B	B1	B2	H	H1	H2	H3	L	
VKPF 4E 400x200	400	420	440	200	220	240	255	500	17,5
VKPF 4D 400x200	400	420	440	200	220	240	255	500	17,5
VKPF 4E 500x250	500	520	540	250	270	290	335	640	24,0
VKPF 4D 500x250	500	520	540	250	270	290	335	640	24,0
VKPF 4E 500x300	500	520	540	300	320	340	365	680	33,0
VKPF 4D 500x300	500	520	540	300	320	340	365	680	33,0
VKPF 4E 600x300	600	620	640	300	320	340	375	680	35,0
VKPF 4D 600x300	600	620	640	300	320	340	375	680	35,0
VKPF 4E 600x350	600	620	640	350	370	390	425	735	49,5
VKPF 4D 600x350	600	620	640	350	370	390	425	735	49,5
VKPF 4D 700x400	700	720	740	400	420	440	480	780	60,0
VKPF 6D 800x500	800	820	840	500	520	540	580	820	70,0
VKPF 4D 800x500	800	820	840	500	520	540	580	820	74,0
VKPF 6D 900x500	900	920	940	500	520	540	580	954	90,0
VKPF 6D 1000x500	1000	1020	1040	500	520	540	580	954	95,0

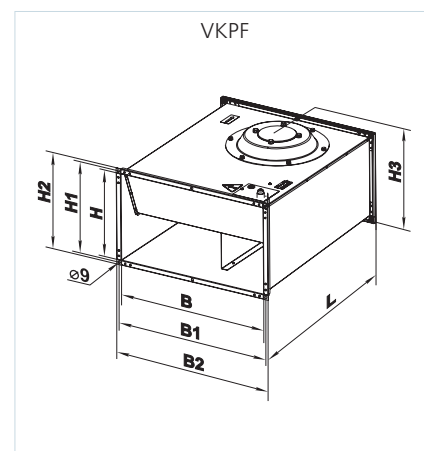



**Technical data:**

	VKPF / VKPFI 4E 600x350	VKPF / VKPFI 4D 600x350	VKPF / VKPFI 4D 700x400	VKPF / VKPFI 6D 800x500
Voltage [V / 50 Hz]	230	400	400	400
Power [W]	2840	2460	3630	2790
Current [A]	13,90	3,93	6,00	5,18
Maximum air flow [m <sup>3</sup> /h]	4260	5020	6450	7610
RPM [min <sup>-1</sup> ]	1260	1300	1320	830
Noise level at 3 m [dBA]	59 / 51*	60 / 52*	65 / 56*	59 / 53*
Maximum operating temperature [°C]	-20 +40	-20 +40	-25 +40	-20 +50
Protection rating	IP X4	IP X4	IP X4	IP X4

\* parameter for VKPFI model

**Technical data:**

	VKPF / VKPFI 4D 800x500	VKPF / VKPFI 6D 900x500	VKPF / VKPFI 6D 1000x500
Voltage [V / 50 Hz]	400	400	400
Power [W]	5850	3870	3870
Current [A]	9,35	7,0	7,0
Maximum air flow [m <sup>3</sup> /h]	8120	9540	9540
RPM [min <sup>-1</sup> ]	1140	930	930
Noise level at 3 m [dBA]	67 / 61*	61 / 55*	61 / 55*
Maximum operating temperature [°C]	-25 +40	-20 +55	-20 +55
Protection rating	IP X4	IP X4	IP X4

\* parameter for VKPFI model

**Fan overall dimensions:**

Type	Dimensions [mm]									Mass [kg]
	B	B1	B2	B3	H	H1	H2	H3	L	
VKPFI 4E 400x200	400	420	440	470	200	220	240	360	500	29,0
VKPFI 4D 400x200	400	420	440	470	200	220	240	360	500	29,0
VKPFI 4E 500x250	500	520	540	570	250	270	290	410	640	40,5
VKPFI 4D 500x250	500	520	540	570	250	270	290	410	640	40,5
VKPFI 4E 500x300	500	520	540	570	300	320	340	460	680	52,5
VKPFI 4D 500x300	500	520	540	570	300	320	340	460	680	52,5
VKPFI 4E 600x300	600	620	640	670	300	320	340	480	680	56,0
VKPFI 4D 600x300	600	620	640	670	300	320	340	480	680	56,0
VKPFI 4E 600x350	600	620	640	670	350	370	390	530	735	72,0
VKPFI 4D 600x350	600	620	640	670	350	370	390	530	735	72,0
VKPFI 4D 700x400	700	720	740	800	400	420	440	620	880	103,0
VKPFI 6D 800x500	800	820	840	900	500	520	540	720	935	120,0
VKPFI 4D 800x500	800	820	840	900	500	520	540	720	935	127,0
VKPFI 6D 900x500	900	920	940	1000	500	520	540	720	1000	142,0
VKPFI 6D 1000x500	1000	1020	1040	1100	500	520	540	720	1000	150,0

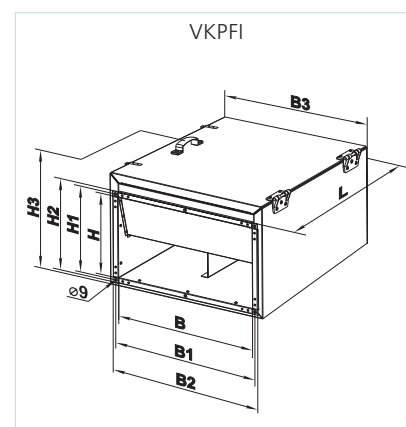

VENTS  
VKPF /  
VKPFI  
FAN SERIES



# RECTANGULAR DUCT FANS

## VENTS VKPF / VKPFI

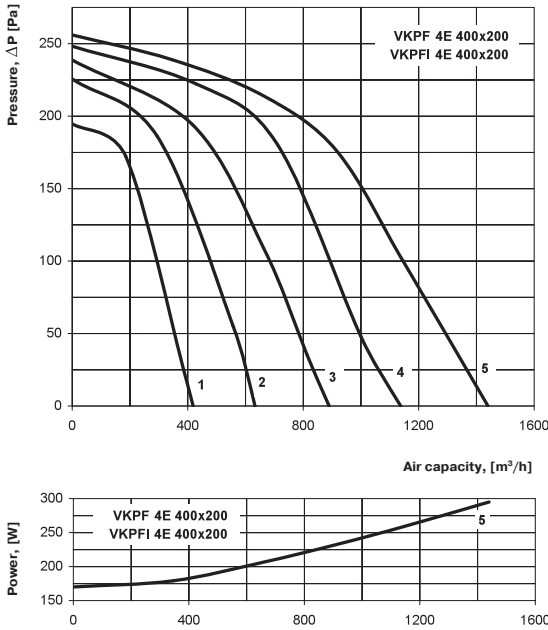

**VKPF 4E 400x200**

Sound-power level		Octave-frequency band [Hz]									
		Hz	Gen	63	125	250	500	1000	2000	4000	8000
$L_{WA}$ to inlet	dBA	69	58	68	63	59	56	53	53	45	
$L_{WA}$ to outlet	dBA	70	53	63	67	62	65	63	58	55	
$L_{WA}$ to environment	dBA	59	34	46	57	52	49	43	40	36	

**VKPF 4E 400x200**

		Hz	Gen	63	125	250	500	1000	2000	4000	8000
$L_{WA}$ to inlet	dBA	66	50	60	58	54	50	49	46	39	
$L_{WA}$ to outlet	dBA	67	48	60	62	58	60	57	54	49	
$L_{WA}$ to environment	dBA	43	24	35	45	41	36	34	29	22	

## VENTS VKPF / VKPFI

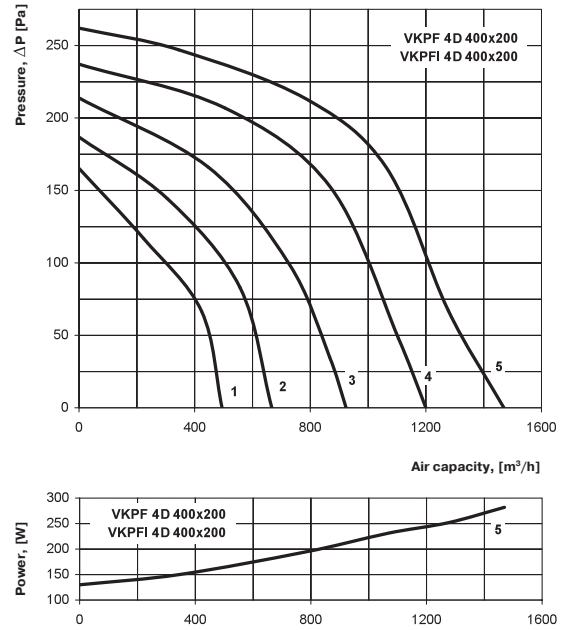

**VKPF 4D 400x200**

Sound-power level		Octave-frequency band [Hz]									
		Hz	Gen	63	125	250	500	1000	2000	4000	8000
$L_{WA}$ to inlet	dBA	72	56	69	65	57	58	57	53	48	
$L_{WA}$ to outlet	dBA	74	54	65	66	61	63	60	61	55	
$L_{WA}$ to environment	dBA	61	34	44	56	52	50	44	40	33	

**VKPF 4D 400x200**

		Hz	Gen	63	125	250	500	1000	2000	4000	8000
$L_{WA}$ to inlet	dBA	65	53	62	60	54	52	50	46	41	
$L_{WA}$ to outlet	dBA	66	48	59	62	58	58	58	53	47	
$L_{WA}$ to environment	dBA	47	24	36	45	38	36	30	29	22	

## VENTS VKPF / VKPFI

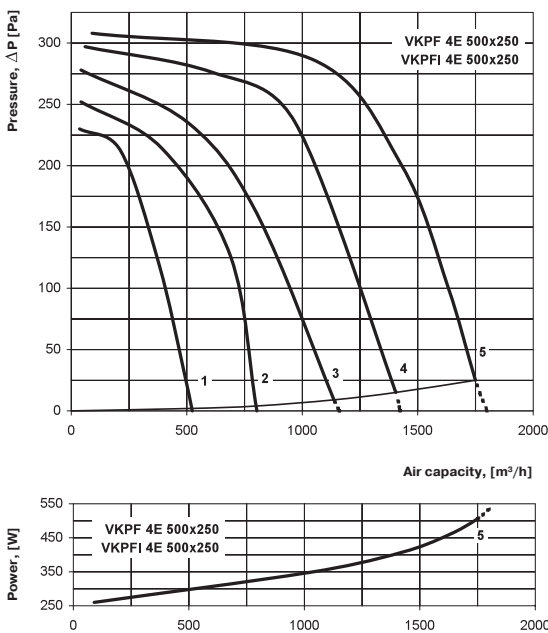

**VKPF 4E 500x250**

Sound-power level		Octave-frequency band [Hz]									
		Hz	Gen	63	125	250	500	1000	2000	4000	8000
$L_{WA}$ to inlet	dBA	72	58	67	62	57	62	64	62	60	
$L_{WA}$ to outlet	dBA	77	57	63	62	66	72	69	68	63	
$L_{WA}$ to environment	dBA	62	41	49	54	53	56	52	51	53	

**VKPF 4E 500x250**

		Hz	Gen	63	125	250	500	1000	2000	4000	8000
$L_{WA}$ to inlet	dBA	68	57	62	58	54	57	58	59	53	
$L_{WA}$ to outlet	dBA	72	50	60	61	60	66	66	61	62	
$L_{WA}$ to environment	dBA	51	29	36	39	43	44	38	37	43	

## VENTS VKPF / VKPFI

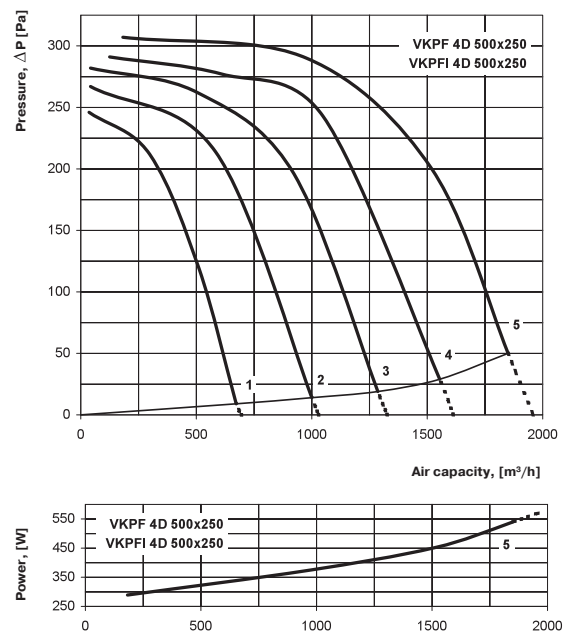

**VKPF 4D 500x250**

Sound-power level		Octave-frequency band [Hz]									
		Hz	Gen	63	125	250	500	1000	2000	4000	8000
$L_{WA}$ to inlet	dBA	74	60	67	64	61	64	62	60	58	
$L_{WA}$ to outlet	dBA	76	57	65	65	67	69	69	68	63	
$L_{WA}$ to environment	dBA	61	41	48	53	53	56	52	50	53	

**VKPF 4D 500x250**

		Hz	Gen	63	125	250	500	1000	2000	4000	8000
$L_{WA}$ to inlet	dBA	67	55	61	57	52	61	58	57	54	
$L_{WA}$ to outlet	dBA	71	49	58	60	62	67	66	61	60	
$L_{WA}$ to environment	dBA	50	27	38	41	44	45	42	40	43	

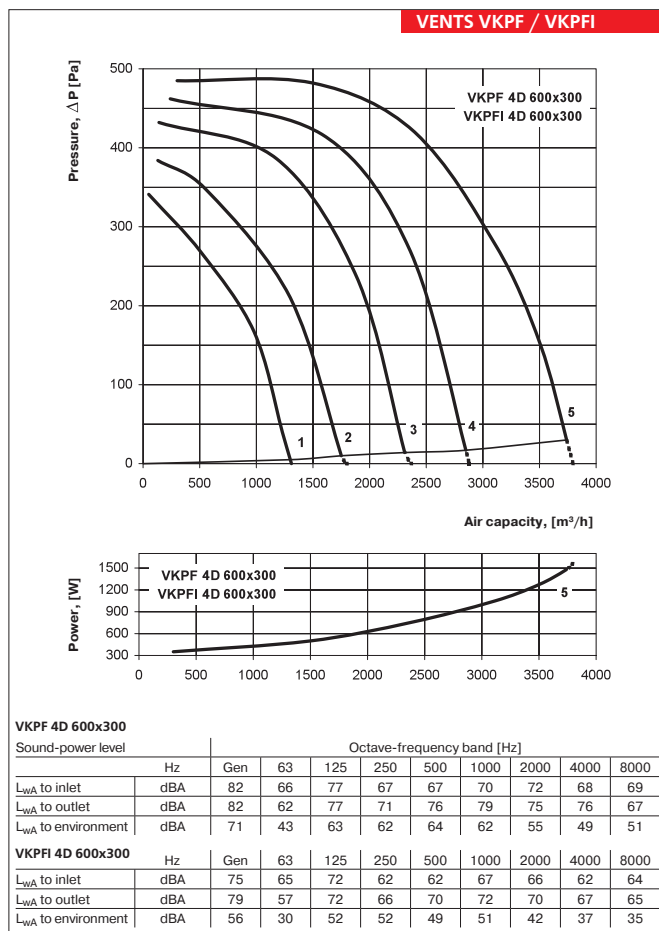
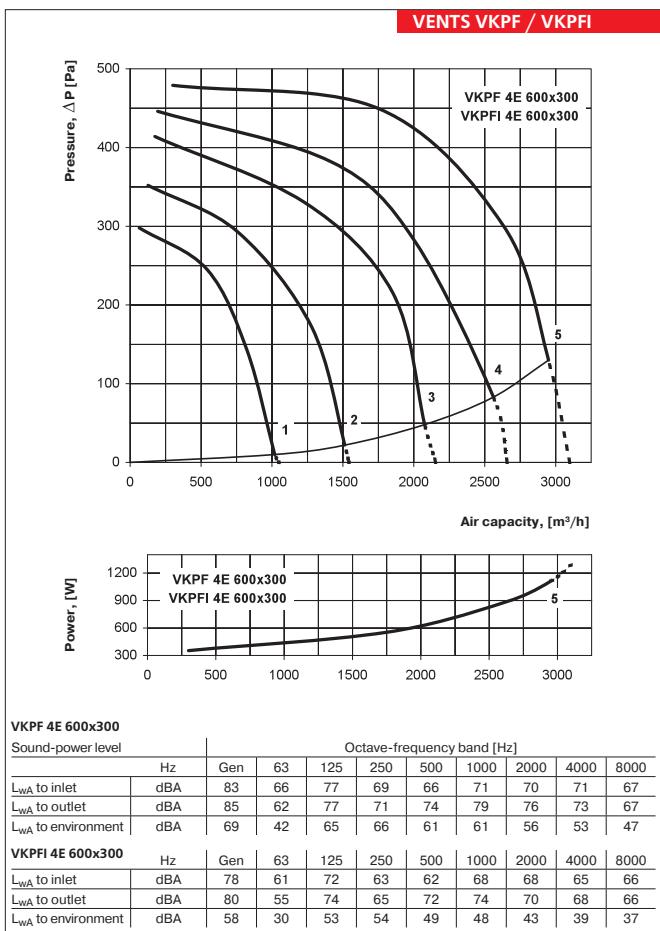
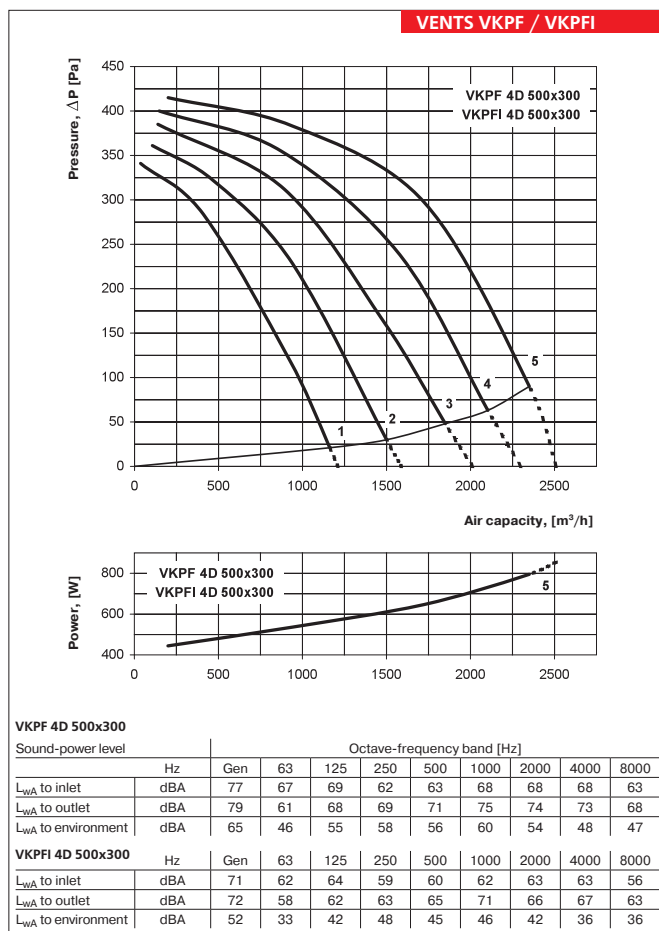
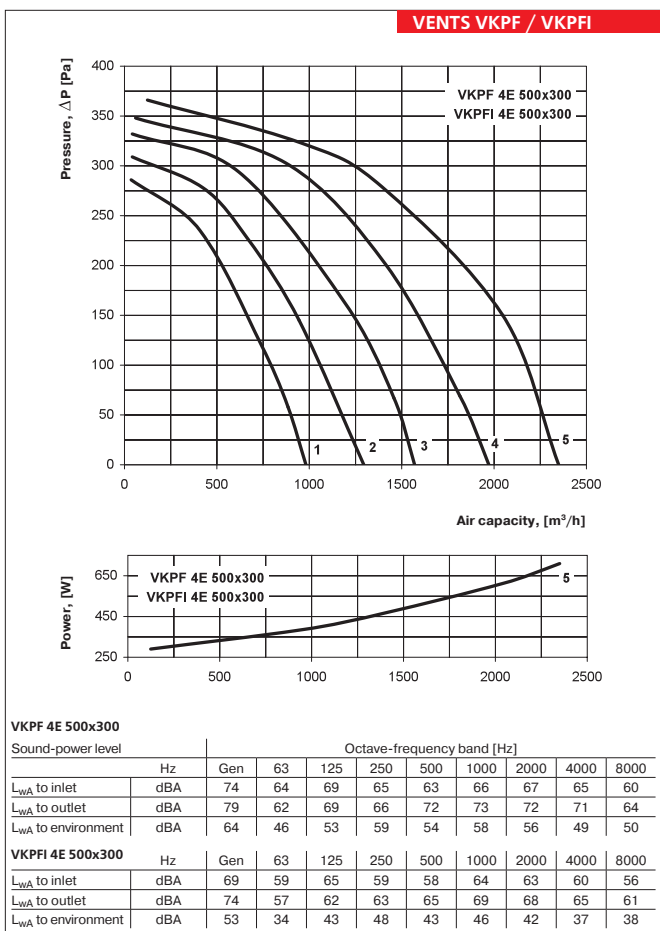

VENTS VKPF / VKPFI

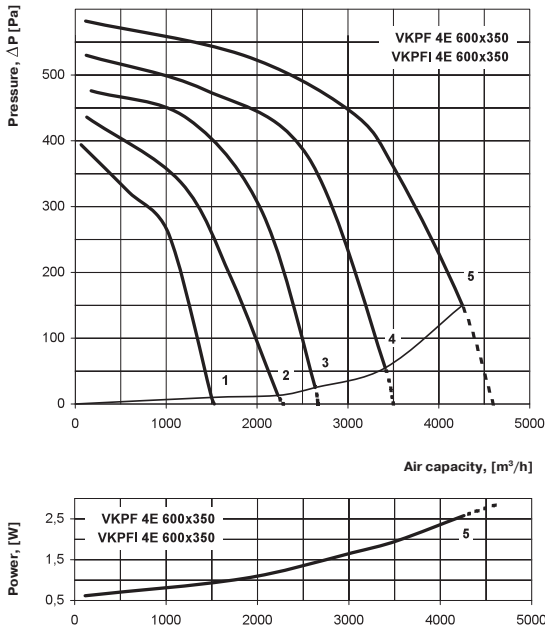

VKPF 4E 600x350

Sound-power level	Hz	Gen	Octave-frequency band [Hz]							
			63	125	250	500	1000	2000	4000	8000
L <sub>WA</sub> to inlet	dBA	78	71	74	65	66	75	72	70	64
L <sub>WA</sub> to outlet	dBA	86	69	73	74	74	78	76	77	68
L <sub>WA</sub> to environment	dBA	67	54	60	63	58	62	55	51	48

VKPF 4E 600x350

Sound-power level	Hz	Gen	Octave-frequency band [Hz]							
			63	125	250	500	1000	2000	4000	8000
L <sub>WA</sub> to inlet	dBA	75	69	69	62	63	70	65	64	62
L <sub>WA</sub> to outlet	dBA	78	62	68	67	71	76	73	69	66
L <sub>WA</sub> to environment	dBA	54	40	51	51	48	48	43	40	35

VENTS VKPF / VKPFI

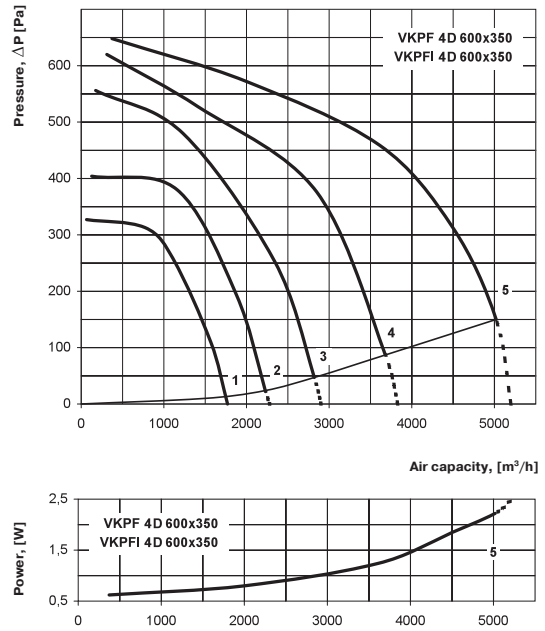

VKPF 4D 600x350

Sound-power level	Hz	Gen	Octave-frequency band [Hz]							
			63	125	250	500	1000	2000	4000	8000
L <sub>WA</sub> to inlet	dBA	80	72	75	69	67	73	71	69	67
L <sub>WA</sub> to outlet	dBA	84	66	74	70	76	79	76	74	68
L <sub>WA</sub> to environment	dBA	68	52	62	65	61	58	56	52	48

VKPF 4D 600x350

Sound-power level	Hz	Gen	Octave-frequency band [Hz]							
			63	125	250	500	1000	2000	4000	8000
L <sub>WA</sub> to inlet	dBA	73	66	72	64	63	69	67	63	59
L <sub>WA</sub> to outlet	dBA	80	64	67	67	69	76	71	69	65
L <sub>WA</sub> to environment	dBA	56	40	48	49	49	48	43	41	38

VENTS VKPF / VKPFI

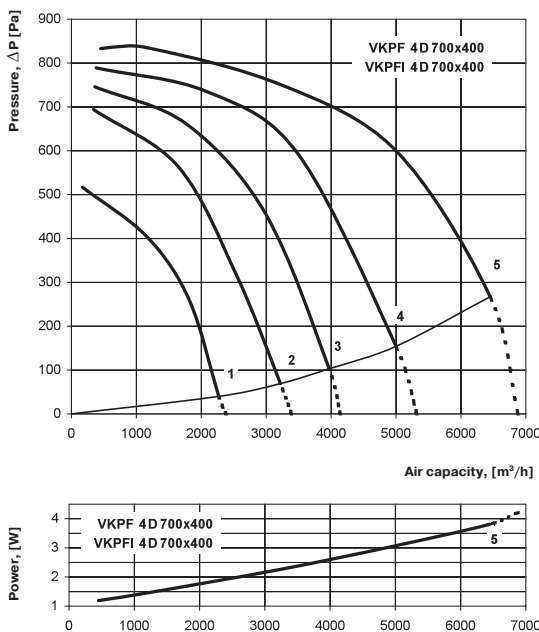

VKPF 4D 700x400

Sound-power level	Hz	Gen	Octave-frequency band [Hz]							
			63	125	250	500	1000	2000	4000	8000
L <sub>WA</sub> to inlet	dBA	82	80	77	70	71	75	73	71	68
L <sub>WA</sub> to outlet	dBA	86	74	77	75	78	83	81	77	71
L <sub>WA</sub> to environment	dBA	71	55	64	69	67	70	63	62	59

VKPF 4D 700x400

Sound-power level	Hz	Gen	Octave-frequency band [Hz]							
			63	125	250	500	1000	2000	4000	8000
L <sub>WA</sub> to inlet	dBA	77	75	70	64	62	73	71	66	64
L <sub>WA</sub> to outlet	dBA	79	68	70	70	72	76	72	74	67
L <sub>WA</sub> to environment	dBA	61	41	54	57	53	56	52	53	47

VENTS VKPF / VKPFI

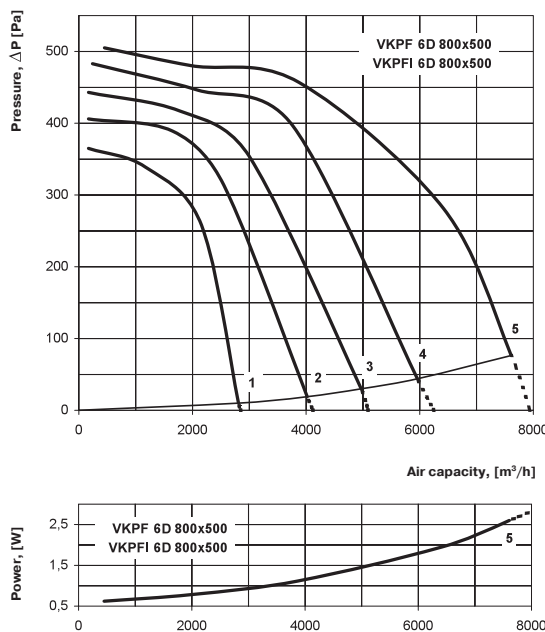

VKPF 6D 800x500

Sound-power level	Hz	Gen	Octave-frequency band [Hz]							
			63	125	250	500	1000	2000	4000	8000
L <sub>WA</sub> to inlet	dBA	77	64	66	66	70	71	70	66	62
L <sub>WA</sub> to outlet	dBA	82	64	66	69	76	74	73	73	64
L <sub>WA</sub> to environment	dBA	64	51	59	58	61	60	55	50	49

VKPF 6D 800x500

Sound-power level	Hz	Gen	Octave-frequency band [Hz]							
			63	125	250	500	1000	2000	4000	8000
L <sub>WA</sub> to inlet	dBA	70	61	60	60	64	67	66	63	58
L <sub>WA</sub> to outlet	dBA	79	58	63	64	72	73	70	69	62
L <sub>WA</sub> to environment	dBA	54	37	45	45	50	48	41	37	39

**VENTS VKPF / VKPFI**

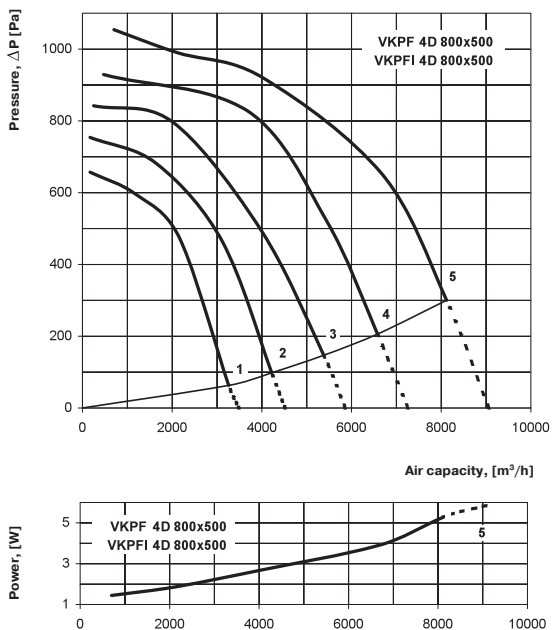

**VKPF 4D 800x500**

Sound-power level	Hz	Octave-frequency band [Hz]								
		Gen	63	125	250	500	1000	2000	4000	8000
$L_{WA}$ to inlet	dBA	82	71	74	75	70	75	75	70	67
$L_{WA}$ to outlet	dBA	90	72	77	76	82	86	85	80	78
$L_{WA}$ to environment	dBA	73	61	68	67	65	70	66	61	60

**VKPFI 4D 800x500**

Sound-power level	Hz	Octave-frequency band [Hz]								
		Gen	63	125	250	500	1000	2000	4000	8000
$L_{WA}$ to inlet	dBA	79	68	68	70	65	71	71	66	62
$L_{WA}$ to outlet	dBA	84	65	72	73	77	81	80	75	71
$L_{WA}$ to environment	dBA	64	49	56	55	53	59	50	48	48

**VENTS VKPF / VKPFI**

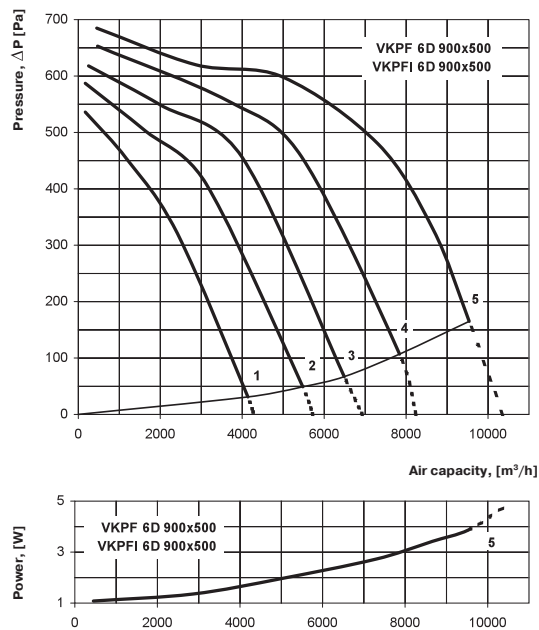

**VKPF 6D 900x500**

Sound-power level	Hz	Octave-frequency band [Hz]								
		Gen	63	125	250	500	1000	2000	4000	8000
$L_{WA}$ to inlet	dBA	78	70	68	63	72	69	71	68	64
$L_{WA}$ to outlet	dBA	83	71	70	70	80	78	79	74	68
$L_{WA}$ to environment	dBA	65	56	64	60	63	58	56	52	51

**VKPFI 6D 900x500**

Sound-power level	Hz	Octave-frequency band [Hz]								
		Gen	63	125	250	500	1000	2000	4000	8000
$L_{WA}$ to inlet	dBA	73	65	64	57	66	68	68	62	57
$L_{WA}$ to outlet	dBA	80	62	66	66	71	74	72	69	65
$L_{WA}$ to environment	dBA	55	45	51	46	52	48	47	41	43

**VENTS VKPF / VKPFI**

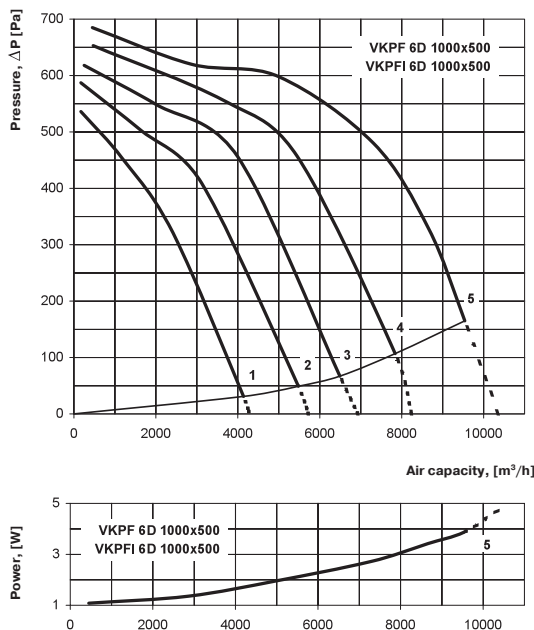

**VKPF 6D 1000x500**

Sound-power level	Hz	Octave-frequency band [Hz]								
		Gen	63	125	250	500	1000	2000	4000	8000
$L_{WA}$ to inlet	dBA	80	73	68	64	74	71	72	69	66
$L_{WA}$ to outlet	dBA	86	70	71	71	78	78	78	75	71
$L_{WA}$ to environment	dBA	69	59	61	59	65	61	58	53	53

**VKPFI 6D 1000x500**

Sound-power level	Hz	Octave-frequency band [Hz]								
		Gen	63	125	250	500	1000	2000	4000	8000
$L_{WA}$ to inlet	dBA	76	68	62	58	66	66	67	64	60
$L_{WA}$ to outlet	dBA	80	64	64	67	74	75	73	67	67
$L_{WA}$ to environment	dBA	59	46	51	50	53	48	46	42	40

Series  
**VENTS VKP EC**



centrifugal fans with the air capacity up to **10850 m<sup>3</sup>/h** for rectangular ducts

■ **Applications**

Supply and exhaust ventilation and air conditioning systems for various premises requiring cost-effective solution and controlled ventilation. EC motors in VKP fan reduce energy consumption by 1, 5-3 times and ensure high performance and low noise level. Such characteristics are of special importance for ventilation of banks, supermarkets, restaurants, hotels and other public facilities including swimming pool ventilation. The fans are compatible with 600x300, 600x350, 700x400, 800x500, 1000x500 mm rectangular ducts.

■ **Design**

Fan casing is made of galvanized steel. All inner components are interconnected by means of rivets. The fan is equipped with 20 mm standard flanges.

■ **Motor**

The impellers with backward-curved blades are powered with high efficient electronically commutated (EC) direct current motors with external rotor. As of today, such motor type is the most advanced solution for energy saving. EC-motors are featured by high performance and the optimal control over the whole range of fan speeds. Premium efficiency reaching up to 90% is an absolute advantage of electronically commutated motors.

■ **Build-in functions and control**

The fan is controlled with the external control signal 0-10 V (air capacity as a function of temperature level, pressure and smoke conditions etc). Should the control value factor get changed the EC-motor changes its speed and the fan boosts as much air capacity to the ventilation system as required. Maximum speed of the fan does not depend on the current frequency and it can operate at 50 or 60 Hz mains supply. The fans can be integrated to the unified PC control system. The respective software allows controlling all the fan units with high accuracy and setting particular operation mode for each fan.

■ **Mounting**

The fans are mounted into the rectangular ducts and require no special fixing in case of direct connection. In case of connection through the flexible connectors the fan is fixed to a building by means of supports, suspension brackets or fixation brackets. The fans can be mounted in any position with respect to the airflow direction which is indicated with a pointer on the casing. Access for the fan maintenance shall be provided. The casing is provided with the removable access door for inspection and maintenance purposes.

Designation key: \_\_\_\_\_

Fan series	Flange diameter [WxH]	Motor
<b>VENTS VKP</b>	600x300, 600x350, 700x400, 800x500, 1000x500	<b>EC</b> – synchronous electronically commutated motor

Accessories



page 238    page 246    page 249    page 252    page 258    page 268    page 295    page 298    page 300    page 301    page 302    page 324



**Technical data:**

	VKP 600x300 EC	VKP 600x350 EC	VKP 700x400 EC	VKP 800x500 EC	VKP 1000x500 EC
Voltage [V / 50/60 Hz]	1~ 200-277	3~ 380-480	3~ 380-480	3~ 380-480	3~ 380-480
Power [kW]	0,48	0,99	1,70	2,95	2,98
Current [A]	3,10	1,70	2,60	4,60	4,60
Maximum air flow [m³/h]	3350	4550	6300	8900	10850
RPM [min <sup>-1</sup> ]	2300	2580	2600	2500	2040
Noise level at 3 m [dBA]	58	60	63	65	69
Maximum operating temperature [°C]	-25 +60	-25 +50	-25 +40	-25 +40	-25 +40
Protection rating	IP X4	IP X4	IP X4	IP X4	IP X4

**Fan overall dimensions:**

Type	Dimensions [mm]								Mass [kg]
	B	B1	B2	H	H1	H2	H3	L	
VKP 600x300 EC	600	620	640	300	320	340	430	680	35,0
VKP 600x350 EC	600	620	640	350	370	390	480	735	49,5
VKP 700x400 EC	700	720	740	400	420	440	540	780	60,0
VKP 800x500 EC	800	820	840	500	520	540	640	880	70,0
VKP 1000x500 EC	1000	1020	1040	500	520	540	640	954	95,0

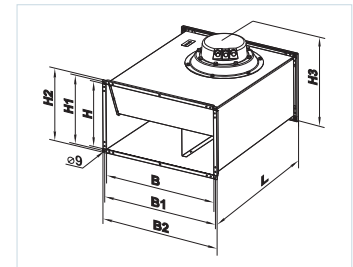

VENTS  
FAN SERIES  
VKP EC



VKP EC fan school class ventilation example



VKP EC fan car parking stand ventilation example

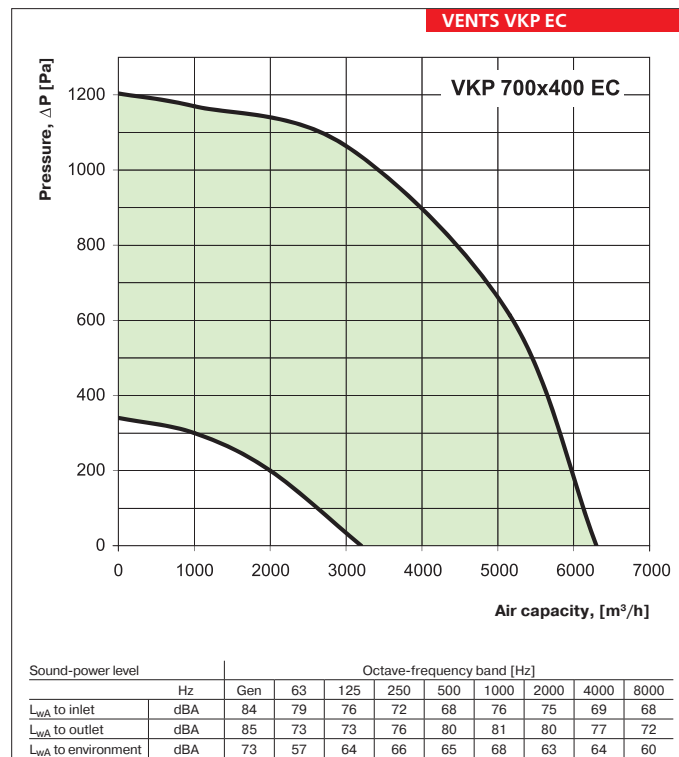
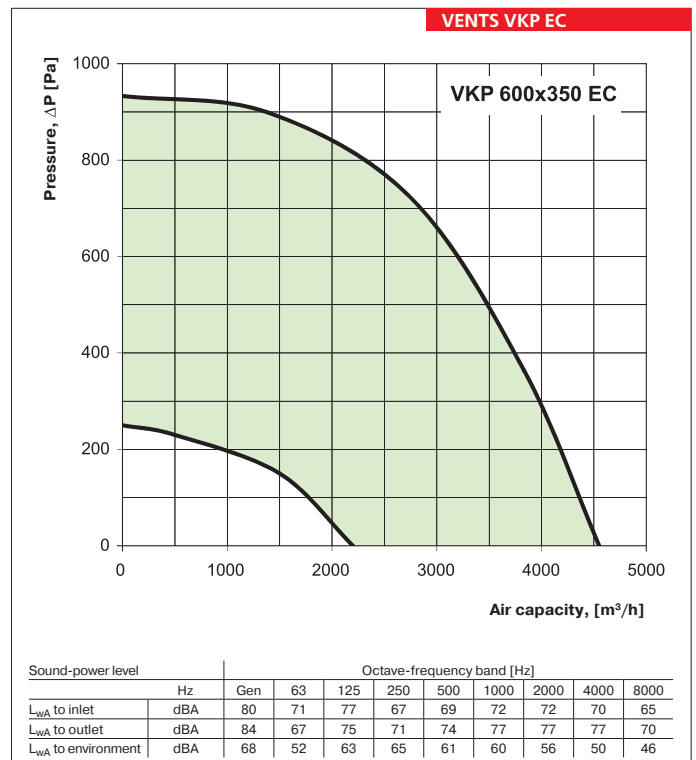
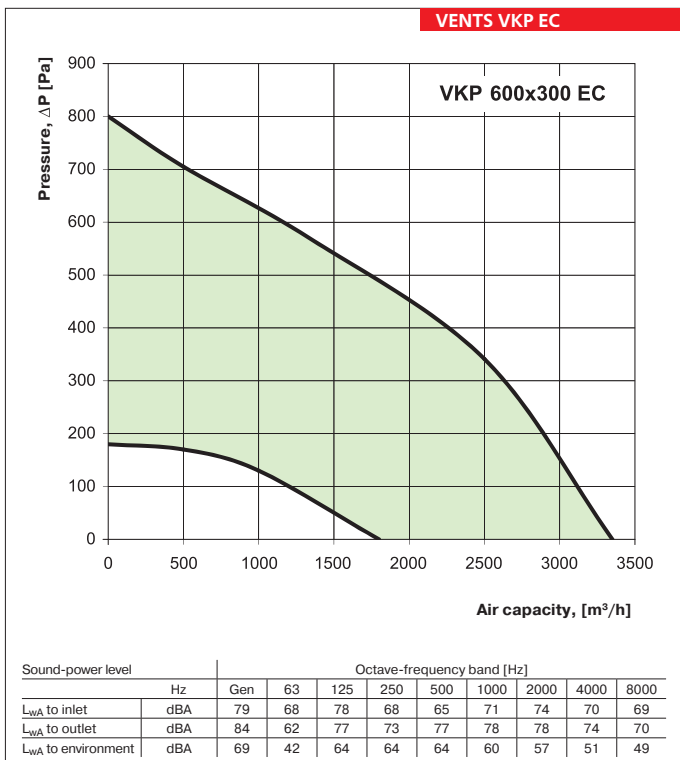

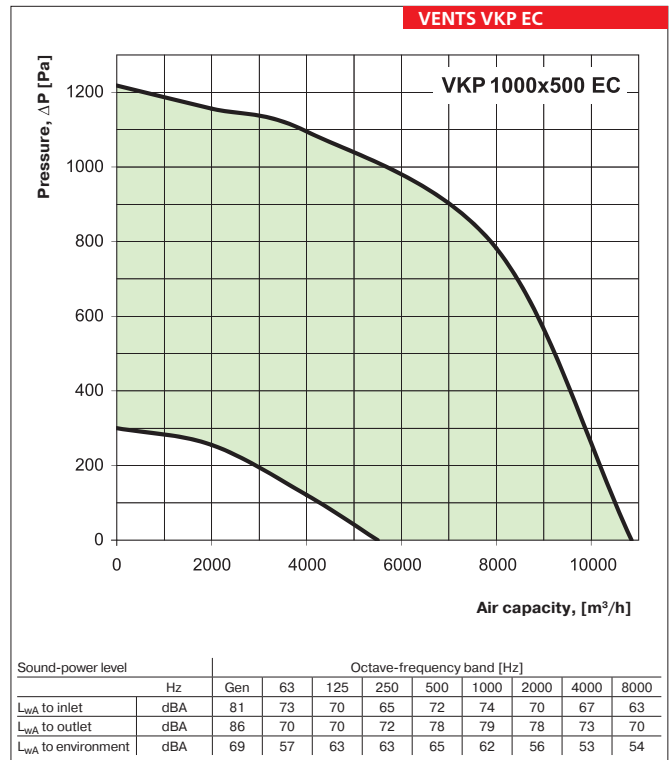
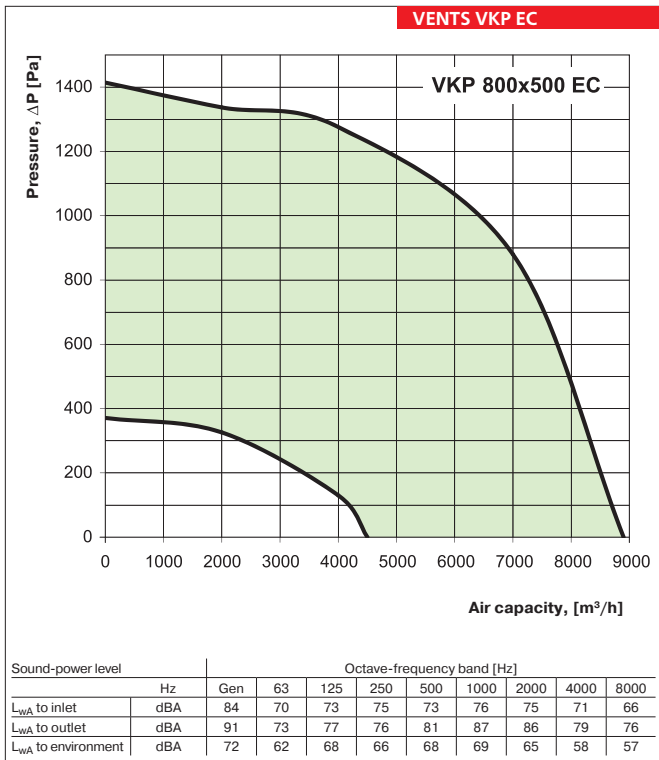

VENTS  
VKP EC

FAN SERIES

Series  
**VENTS VKP**



Centrifugal fans with the air capacity up to **2970 m<sup>3</sup>/h** for rectangular ducts

Series  
**VENTS VKPI**



Centrifugal sound- and heat-insulated fans with the air capacity up to **2970 m<sup>3</sup>/h** for rectangular ducts

■ **Applications**

Supply and exhaust ventilation systems for various premises with a limited mounting space. For connection with 400x200, 500x250, 500x300, 600x300, 600x350 mm the rectangular ducts.

■ **Design**

Fan casing is made of galvanized steel. VKPI models are heat- and sound-insulated with 50 mm mineral wool layer.

■ **Motor**

Impellers with backward-curved impeller blades made of galvanized steel are powered by means of the 2- or 4-pole asynchronous motors with external rotor. Motors are supplied with incorporated overheating

protection with automatic restart or the thermal protection terminals leaded outside for connection to the external protection devices depending on the model, see the wiring diagram. motor is equipped with ball bearings for long service life. For precise features, safe operation and low noise, each impeller is dynamically balanced while assembly. Motor protection rating IP 44.

■ **Speed control**

Both smooth or step speed control is performed with the thyristor or autotransformer controller. Several fans can be connected to one controller in case the total power and operating current do not exceed the controller rated values.

■ **Mounting**

The fans are mounted into the rectangular ducts and require no special fixing in case of direct connection. In case of connection through the flexible connectors the fan is fixed to a building by means of supports, suspension brackets or fixation brackets. Fans can be mounted in any position with respect to the airflow direction (indicated with an arrow on the casing). Access for the fan maintenance shall be provided. The fan is powered through the external terminals. The casing is equipped with the removable access cover for maintenance purposes.

**Designation key:** \_\_\_\_\_

Fan series		Motor modification		Flange diameter [WxH]
<b>VENTS VKP</b>	I – modification in sound- and heat-insulated casing	Number of poles	Phase	400x200, 500x250, 500x300, 600x300, 600x350
		4 2	E – single phase D – three phases	

**Accessories**



page 238   page 246   page 249   page 252   page 258   page 268   page 298   page 300   page 301   page 302   page 314   page 315

**Technical data:**

	VKP / VKPI 2E 400x200	VKP / VKPI 2E 500x250	VKP / VKPI 4E 500x300	VKP / VKPI 4D 500x300
Voltage [V / 50 Hz]	230	230	230	400
Power [W]	138	305	140	136
Current [A]	0,60	1,32	0,57	0,34
Maximum air flow [m <sup>3</sup> /h]	930	1720	1700	1380
RPM [min <sup>-1</sup> ]	2600	2550	1390	1360
Noise level at 3 m [dBA]	59 / 51*	61 / 53*	53 / 45*	53 / 45*
Maximum operating temperature [°C]	-25 +45	-25 +45	-25 +45	-25 +65
Protection rating	IPX4	IPX4	IPX4	IPX4

\* parameter for VKPI fan

**Technical data:**

	VKP / VKPI 4E 600x300	VKP / VKPI 4D 600x300	VKP / VKPI 4E 600x350	VKP / VKPI 4D 600x350	
Voltage [V / 50 Hz]	230	400	230	400Δ	400Y
Power [W]	220	230	470	510	380
Current [A]	0,90	0,52	2,37	1,41	0,70
Maximum air flow [m <sup>3</sup> /h]	2470	2530	2950	2970	2660
RPM [min <sup>-1</sup> ]	1400	1360	1370	1415	1235
Noise level at 3 m [dBA]	55 / 47*	53 / 46*	67 / 59*	64 / 55*	63 / 55*
Maximum operating temperature [°C]	-25 +45	-25 +70	-40 +80	-40 +60	-40 +80
Protection rating	IPX4	IPX4	IPX4	IPX4	

\* parameter for VKPI fan

**Fan overall dimensions:**

Type	Dimensions [mm]								Mass [kg]
	B	B1	B2	H	H1	H2	H3	L	
VKP 2E 400x200	400	420	440	200	220	240	240	500	13,6
VKP 2E 500x250	500	520	540	250	270	290	290	640	17,7
VKP 4E 500x300	500	520	540	300	320	340	340	680	25,5
VKP 4D 500x300	500	520	540	300	320	340	340	680	25,5
VKP 4E 600x300	600	620	640	300	320	340	342	680	31,5
VKP 4D 600x300	600	620	640	300	320	340	342	680	32,5
VKP 4E 600x350	600	620	640	350	370	390	390	735	41,5
VKP 4D 600x350	600	620	640	350	370	390	390	735	41,5

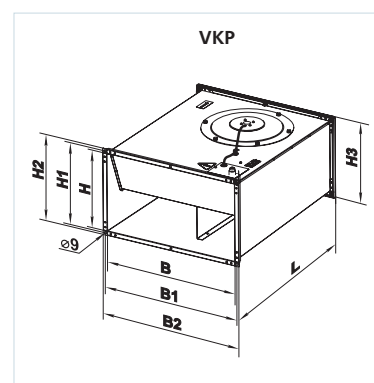

**Fan overall dimensions:**

Type	Dimensions [mm]									Mass [kg]
	B	B1	B2	B3	H	H1	H2	H3	L	
VKPI 2E 400x200	400	420	440	500	200	220	240	360	500	24,4
VKPI 2E 500x250	500	520	540	600	250	270	290	410	640	34,0
VKPI 4E 500x300	500	520	540	600	300	320	340	460	680	45,0
VKPI 4D 500x300	500	520	540	600	300	320	340	460	680	45,0
VKPI 4E 600x300	600	620	640	700	300	320	340	460	680	52,5
VKPI 4D 600x300	600	620	640	700	300	320	340	460	680	53,0
VKPI 4E 600x350	600	620	640	700	350	370	390	530	735	64,0
VKPI 4D 600x350	600	620	640	700	350	370	390	530	735	64,0

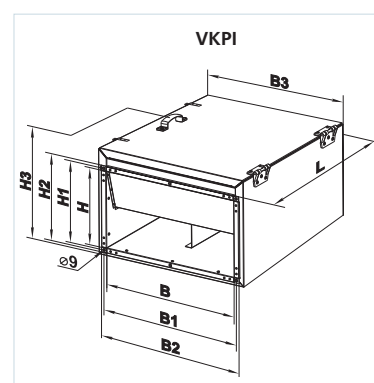

VENTS VKP /  
VKPI  
FAN SERIES



VENTS VKP / VKPI

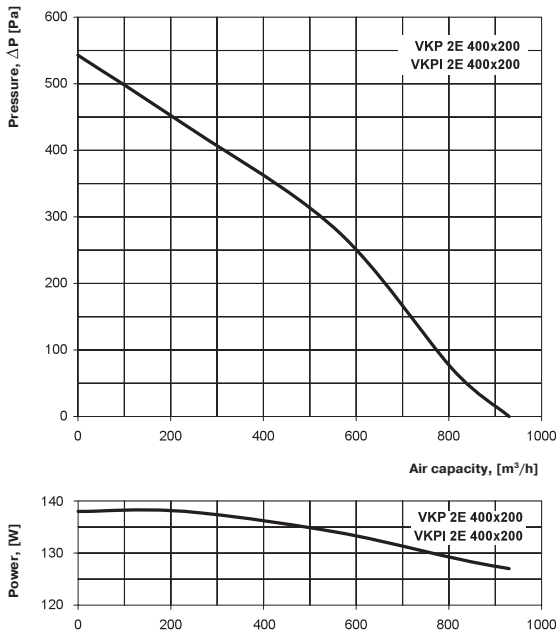

VKP 2E 400x200

Sound-power level	Hz	Gen	Octave-frequency band [Hz]							
			63	125	250	500	1000	2000	4000	8000
L <sub>WA</sub> to inlet	dBA	71	54	63	68	64	64	58	54	45
L <sub>WA</sub> to outlet	dBA	75	53	62	66	68	69	66	60	48
L <sub>WA</sub> to environment	dBA	58	36	48	56	54	50	46	41	32

VKPI 2E 400x200

Sound-power level	Hz	Gen	Octave-frequency band [Hz]							
			63	125	250	500	1000	2000	4000	8000
L <sub>WA</sub> to inlet	dBA	65	45	57	60	60	57	53	49	43
L <sub>WA</sub> to outlet	dBA	70	47	59	61	66	64	60	55	43
L <sub>WA</sub> to environment	dBA	48	26	37	45	43	35	32	29	22

VENTS VKP / VKPI

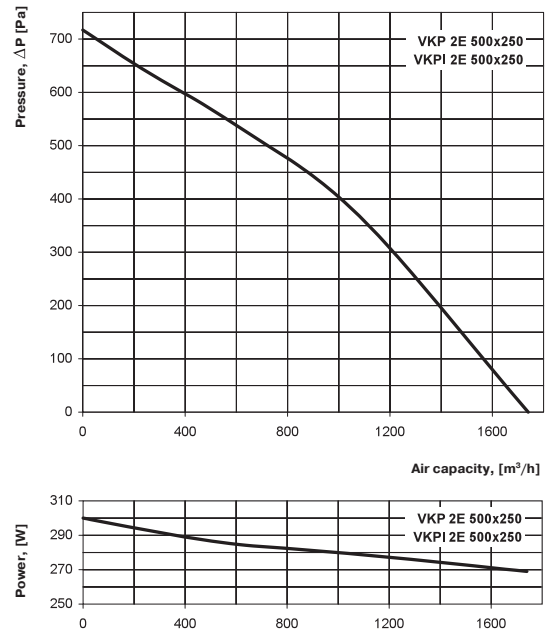

VKP 2E 500x250

Sound-power level	Hz	Gen	Octave-frequency band [Hz]							
			63	125	250	500	1000	2000	4000	8000
L <sub>WA</sub> to inlet	dBA	69	60	68	60	56	56	49	46	46
L <sub>WA</sub> to outlet	dBA	70	54	65	64	63	60	56	49	44
L <sub>WA</sub> to environment	dBA	53	41	48	47	44	40	38	33	35

VKPI 2E 500x250

Sound-power level	Hz	Gen	Octave-frequency band [Hz]							
			63	125	250	500	1000	2000	4000	8000
L <sub>WA</sub> to inlet	dBA	62	52	60	56	51	50	43	42	40
L <sub>WA</sub> to outlet	dBA	63	48	59	60	55	57	53	45	39
L <sub>WA</sub> to environment	dBA	41	27	35	37	31	29	27	25	27

VENTS VKP / VKPI

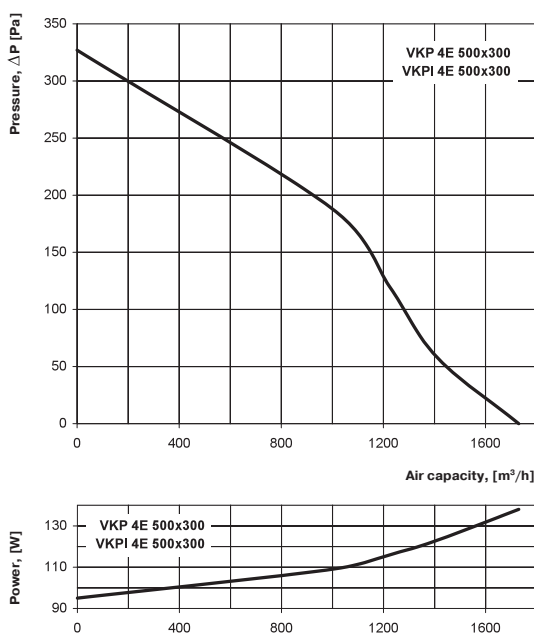

VKP 4E 500x300

Sound-power level	Hz	Gen	Octave-frequency band [Hz]							
			63	125	250	500	1000	2000	4000	8000
L <sub>WA</sub> to inlet	dBA	69	58	63	64	55	57	58	51	46
L <sub>WA</sub> to outlet	dBA	73	57	60	72	65	65	64	57	48
L <sub>WA</sub> to environment	dBA	56	44	52	51	51	49	48	43	33

VKPI 4E 500x300

Sound-power level	Hz	Gen	Octave-frequency band [Hz]							
			63	125	250	500	1000	2000	4000	8000
L <sub>WA</sub> to inlet	dBA	64	51	59	60	48	55	51	49	40
L <sub>WA</sub> to outlet	dBA	70	50	55	64	59	62	59	50	43
L <sub>WA</sub> to environment	dBA	44	31	37	40	39	38	35	32	20

VENTS VKP / VKPI

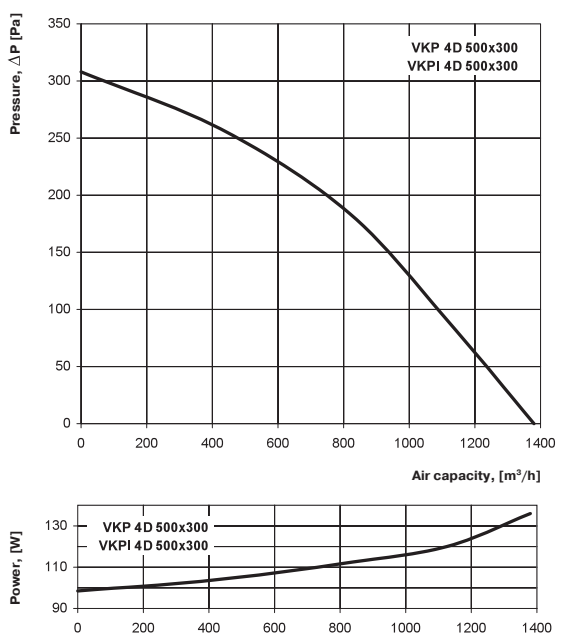

VKP 4D 500x300

Sound-power level	Hz	Gen	Octave-frequency band [Hz]							
			63	125	250	500	1000	2000	4000	8000
L <sub>WA</sub> to inlet	dBA	69	58	62	65	55	58	58	55	45
L <sub>WA</sub> to outlet	dBA	71	56	62	69	64	66	63	59	50
L <sub>WA</sub> to environment	dBA	55	42	51	51	52	52	48	43	32

VKPI 4D 500x300

Sound-power level	Hz	Gen	Octave-frequency band [Hz]							
			63	125	250	500	1000	2000	4000	8000
L <sub>WA</sub> to inlet	dBA	62	51	59	63	49	55	54	49	39
L <sub>WA</sub> to outlet	dBA	66	51	57	67	59	63	60	50	42
L <sub>WA</sub> to environment	dBA	44	31	38	38	38	36	38	31	22

**VENTS VKP / VKPI**

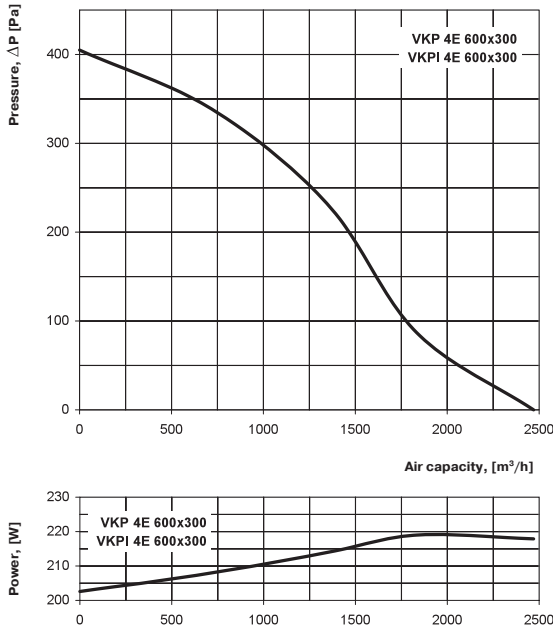

**VKP 4E 600x300**

Sound-power level	Hz	Octave-frequency band [Hz]								
		Gen	63	125	250	500	1000	2000	4000	8000
$L_{WA}$ to inlet	dBA	72	63	67	69	56	61	61	54	48
$L_{WA}$ to outlet	dBA	78	57	65	73	68	69	69	61	54
$L_{WA}$ to environment	dBA	61	43	55	54	55	53	49	48	35

Sound-power level	Hz	Octave-frequency band [Hz]								
		Gen	63	125	250	500	1000	2000	4000	8000
$L_{WA}$ to inlet	dBA	68	58	62	64	55	55	53	51	42
$L_{WA}$ to outlet	dBA	71	54	60	67	62	64	61	54	49
$L_{WA}$ to environment	dBA	48	34	42	43	41	40	37	36	23

**VENTS VKP / VKPI**

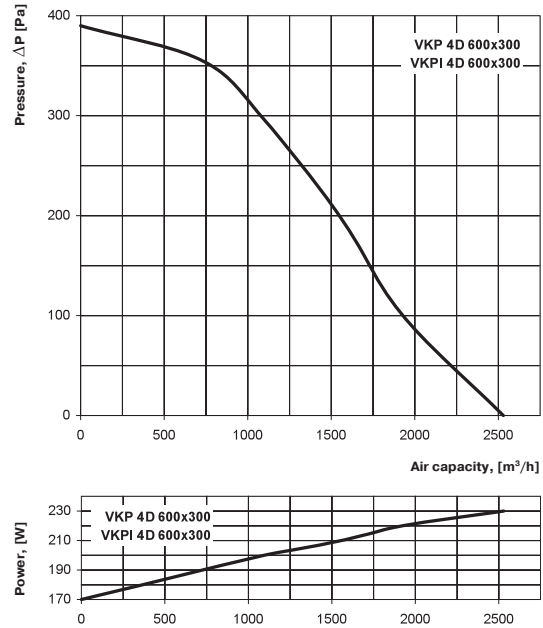

**VKP 4D 600x300**

Sound-power level	Hz	Octave-frequency band [Hz]								
		Gen	63	125	250	500	1000	2000	4000	8000
$L_{WA}$ to inlet	dBA	72	61	69	67	60	62	58	56	50
$L_{WA}$ to outlet	dBA	76	59	66	73	68	69	66	58	51
$L_{WA}$ to environment	dBA	59	45	53	56	54	54	53	47	38

Sound-power level	Hz	Octave-frequency band [Hz]								
		Gen	63	125	250	500	1000	2000	4000	8000
$L_{WA}$ to inlet	dBA	69	55	60	66	53	55	56	52	43
$L_{WA}$ to outlet	dBA	71	56	61	70	62	65	60	55	45
$L_{WA}$ to environment	dBA	46	31	43	41	40	41	40	35	23

**VENTS VKP / VKPI**

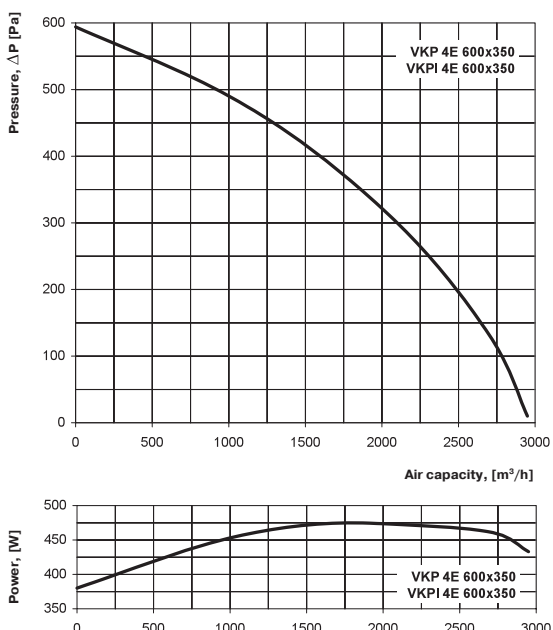

**VKP 4E 600x350**

Sound-power level	Hz	Octave-frequency band [Hz]								
		Gen	63	125	250	500	1000	2000	4000	8000
$L_{WA}$ to inlet	dBA	78	58	78	75	60	64	65	67	55
$L_{WA}$ to outlet	dBA	79	58	69	75	67	70	69	69	56
$L_{WA}$ to environment	dBA	64	37	61	55	51	54	49	43	35

Sound-power level	Hz	Octave-frequency band [Hz]								
		Gen	63	125	250	500	1000	2000	4000	8000
$L_{WA}$ to inlet	dBA	75	53	72	71	54	58	63	60	52
$L_{WA}$ to outlet	dBA	74	52	62	69	62	67	65	64	54
$L_{WA}$ to environment	dBA	51	25	51	44	40	42	38	34	23

**VENTS VKP / VKPI**



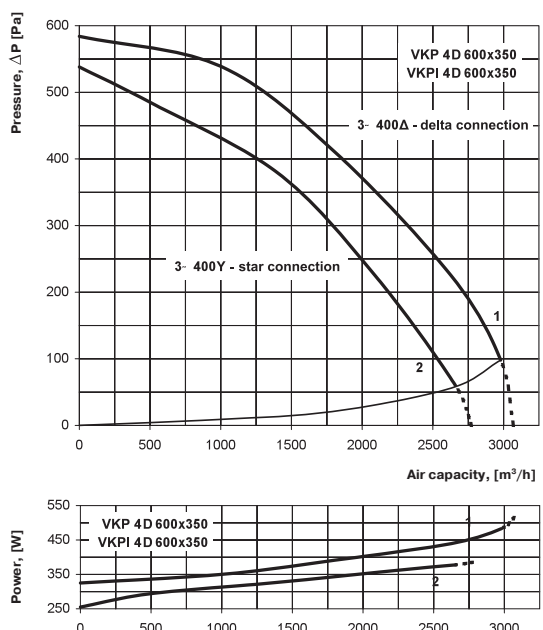



















































**VKP 4D 600x350**

Sound-power level	Hz	Octave-frequency band [Hz]								
		Gen	63	125	250	500	1000	2000	4000	8000
$L_{WA}$ to inlet	dBA	72	57	59	72	66	64	65	58	47
$L_{WA}$ to outlet	dBA	81	60	67	76	74	74	69	59	50
$L_{WA}$ to environment	dBA	65	40	53	61	57	55	54	47	38

Sound-power level	Hz	Octave-frequency band [Hz]								
		Gen	63	125	250	500	1000	2000	4000	8000
$L_{WA}$ to inlet	dBA	70	54	56	65	62	60	58	49	40
$L_{WA}$ to outlet	dBA	74	57	63	73	70	68	65	57	47
$L_{WA}$ to environment	dBA	52	27	41	50	43	45	41	35	26

# ELECTRICAL ACCESSORIES COMPATIBILITY

																	
		VKPF 4E 400x200 VKPFI 4E 400x200	VKPF 4D 400x200 VKPFI 4D 400x200	VKPF 4E 500x250 VKPFI 4E 500x250	VKPF 4D 500x250 VKPFI 4D 500x250	VKPF 4E 500x300 VKPFI 4E 500x300	VKPF 4D 500x300 VKPFI 4D 500x300	VKPF 4E 600x300 VKPFI 4E 600x300	VKPF 4D 600x300 VKPFI 4D 600x300	VKPF 4E 600x350 VKPFI 4E 600x350	VKPF 4D 600x350 VKPFI 4D 600x350	VKPF 4D 700x400 VKPFI 4D 700x400	VKPF 6D 800x500 VKPFI 6D 800x500	VKPF 4D 800x500 VKPFI 4D 800x500	VKPF 6D 900x500 VKPFI 6D 900x500	VKPF 6D 1000x500 VKPFI 6D 1000x500	
<b>Thyristor speed controllers</b>																	
	RS-1-300	•															
	RS-1-400	•															
	RS-1 N (V)	•															
	RS-1,5 N (V)	•															
	RS-2 N (V)	•															
	RS-2,5 N (V)	•		•													
	RS-0,5-PS	•															
	RS-1,5-PS	•															
	RS-2,5-PS	•		•													
	RS-4,0-PS	•		•		•											
	RS-1,5-T	•															
	RS-3,0-T	•		•													
	RS-5,0-T	•		•		•											
	RS-10,0-T	•		•		•		•									
	RS-1,5-TA	•															
	RS-3,0-TA	•		•													
	RS-5,0-TA	•		•		•											
	RS-10,0-TA	•		•		•		•									
<b>Transformer speed controllers</b>																	
	RSA5E-2-P	•															
	RSA5E-2-M	•															
	RSA5E-3-M	•		•													
	RSA5E-4-M	•		•		•											
	RSA5E-12-M	•		•		•		•									
	RSA5E-1,5-T	•															
	RSA5E-3,5-T	•		•		•											
	RSA5E-5,0-T	•		•		•		•									
	RSA5E-8,0-T	•		•		•		•									
	RSA5E-10,0-T	•		•		•		•									
	RSA5D-1,5-T		•		•												
	RSA5D-3,5-T		•		•		•		•								
	RSA5D-5-M		•		•		•		•		•						
	RSA5D-8-M		•		•		•		•		•	•	•			•	•
	RSA5D-10-M		•		•		•		•		•	•	•	•		•	•
	RSA5D-12-M		•		•		•		•		•	•	•	•		•	•
<b>Frequency speed controllers</b>																	
	VFED-200-TA		•		•												
	VFED-400-TA		•		•		•										
	VFED-750-TA		•		•		•		•								
	VFED-1100-TA		•		•		•		•		•		•				
	VFED-1500-TA		•		•		•		•		•	•	•			•	•
<b>Temperature regulators</b>																	
	RTS-1-400																
	RTSD-1-400																
	RT-10	•															
<b>Multi-speed fan switches</b>																	
	P2-5,0																
	P3-5,0																
	P5-5,0																
	P2-1-300																
	P3-1-300																
<b>EC-motors controllers</b>																	
	R-1/010																
<b>Sensors</b>																	
	T-1,5 N	•															
	TH-1,5 N	•															
	TF-1,5 N	•															
	TP-1,5 N	•															

• recommended

• suitable

		VKP 600x300 EC	VKP 600x350 EC	VKP 700x400 EC	VKP 800x500 EC	VKP 1000x500 EC	VKP 2E 400x200 VKP12E 400x200	VKP 2E 500x250 VKP12E 500x250	VKP 4E 500x300 VKP14E 500x300	VKP 4D 500x300 VKP14D 500x300	VKP 4E 600x300 VKP14E 600x300	VKP 4D 600x300 VKP14D 600x300	VKP 4E 600x350 VKP14E 600x350	VKP 4D 600x350 VKP14D 600x350	
<b>Thyristor speed controllers</b>															
	RS-1-300						•	•	•			•			
	RS-1-400						•	•	•			•			
	RS-1 N (V)						•		•			•			
	RS-1,5 N (V)						•	•	•			•			
	RS-2 N (V)						•	•	•			•			
	RS-2,5 N (V)						•	•	•			•			
	RS-0,5-PS												•		
	RS-1,5-PS						•	•	•			•			
	RS-2,5-PS						•	•	•			•			
	RS-4,0-PS						•	•	•			•			
	RS-1,5-T						•	•	•			•			
	RS-3,0-T						•	•	•			•			
	RS-5,0-T						•	•	•			•			
	RS-10,0-T							•				•			
	RS-1,5-TA						•	•	•			•			
	RS-3,0-TA						•	•	•			•			
	RS-5,0-TA						•	•	•			•			
	RS-10,0-TA							•				•			
<b>Transformer speed controllers</b>															
	RSA5E-2-P						•	•	•			•			
	RSA5E-2-M						•	•	•			•			
	RSA5E-3-M						•	•	•			•			
	RSA5E-4-M						•	•	•			•			
	RSA5E-12-M						•	•	•			•			
	RSA5E-1,5-T						•	•	•			•			
	RSA5E-3,5-T						•	•	•			•			
	RSA5E-5,0-T						•	•	•			•			
	RSA5E-8,0-T						•	•	•			•			
	RSA5E-10,0-T						•	•	•			•			
	RSA5D-1,5-T								•			•		•	
	RSA5D-3,5-T								•			•		•	
	RSA5D-5-M								•			•		•	
	RSA5D-8-M								•			•		•	
	RSA5D-10-M								•			•		•	
	RSA5D-12-M								•			•		•	
<b>Frequency speed controllers</b>															
	VFED-200-TA								•			•		•	
	VFED-400-TA								•			•		•	
	VFED-750-TA								•			•		•	
	VFED-1100-TA								•			•		•	
	VFED-1500-TA								•			•		•	
<b>Temperature regulators</b>															
	RTS-1-400														
	RTSD-1-400														
	RT-10						•	•	•			•			
<b>Multi-speed fan switches</b>															
	P2-5,0														
	P3-5,0														
	P5-5,0														
	P2-1-300														
	P3-1-300														
<b>EC-motors controllers</b>															
	R-1/010	•	•	•	•	•									
<b>Sensors</b>															
	T-1,5 N						•	•	•			•			
	TH-1,5 N						•	•	•			•			
	TF-1,5 N						•	•	•			•			
	TP-1,5 N						•	•	•			•			

• recommended

• suitable

# CHIMNEY CENTRIFUGAL FANS

## IT'S NOT ONLY FIREPLACE THAT MAKES YOU FEEL WARM

A fireplace in the country house brings comfort and romance; it is a unique energy of country life. The warmth of fireplace recovers serenity of mind, calms and harmonizes our thoughts in a philosophical manner. And, of course, it makes us feel warm.

Chimney fans designed for hot air distribution allow creating fully-featured air heating system based on a fireplace. Such system is the perfect solution for heating of seasonal houses that serve as a secondary residence during winter time and provide fast and efficient hot air distribution from chimney to other premises.

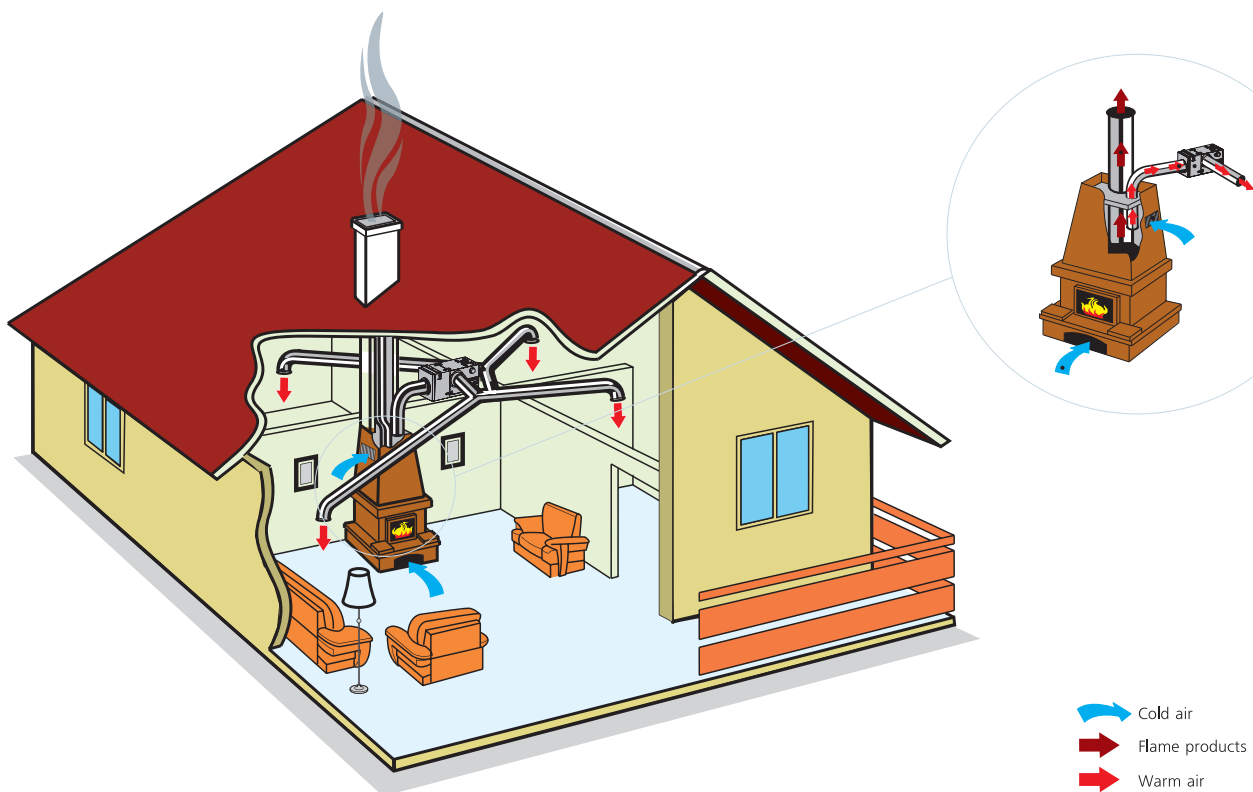

### ▶ VENTS KAM Series



- ▶ Chimney fan is designed for house heating system management using heat of chimney or fireplace. It can be also used as a base for backup heating source. Air capacity of the fan is up to 540 m<sup>3</sup>/h. The fans are compatible with Ø 125, 140, 150 and 160 mm round ducts.





**Chimney centrifugal fan  
VENTS KAM**

Air capacity – up to 540 m<sup>3</sup>/h

page  
86



**Chimney centrifugal fan  
VENTS KAM Eco**

Air capacity – up to 470 m<sup>3</sup>/h

page  
86



**Chimney centrifugal fan  
VENTS KAM EcoDuo**

Air capacity – up to 470 m<sup>3</sup>/h

page  
86

Series  
**VENTS KAM**



Chimney centrifugal fan for house heating system management using heat of chimney or fireplace. It can be also used as a base for backup heating source.

■ **Applications**

Chimney fans for hot air distribution allow creating fully-featured air heating system based on a fireplace. Such system is the perfect solution for heating of seasonal houses that serve as a second residence during winter time and provides fast and efficient hot air distribution from chimney to other premises. Used for air distribution with the air temperature range 0°C to +150°C.

■ **Design**

The fan casing is made of galvanized steel and equipped with heat- and sound insulation of fire-resistant mineral wool. The casing is perforated for the internal air circulation and motor cooling. The temperature regulator is used for setting the temperature level for the fan switching on and off. Fan startup is effected within the range of 0 °C to +90°C depending on the air temperature generated inside the fireplace heat-exchanger.

■ **Motor**

The fans are supplied with single-phase motors for operation in 230/50Hz power supply network. Insulation Class F. The motors have built-in overheating protection with automatic restart. The motor is placed off-airflow and is equipped with forward-curved impeller blades as well as ball bearings for long service life. The fan models marked KAM are equipped with asynchronous motors and extra impeller for air blowing-off and cooling. The fan motors models marked KAM Eco are equipped with the external rotor. The fan motors models marked KAM EcoDuo have two speeds and equipped with the external rotor.

■ **Speed control**

Both smooth and step fan control is performed by means of the thyristor or autotransformer (Models KAM, KAM Eco). The fan speed is controlled within the range of 0 to 100%. KAM EcoDuo fan speed is controlled by means of the speed switch.

■ **Mounting**

The fireplace fans are designed for connection with round air ducts. The fans can be mounted in any

position with respect to the airflow direction indicated with a pointer on the casing. Access for the fan maintenance shall be reserved. Warm air feed ducts shall be laid between the fan and each of the heated rooms. Concealed air ducts system with forced warm air circulation allows saving useful space in the house and fits to the house design.

■ **Accessories**

**FFK** – removable G3 metal filter for boosted air purification. The filter is connected to the fan casing by lock-latches to provide easy removal of the filter for cleaning.

**KFK** – removable metal mixing chamber with incorporated thermal control damper and G3 filter for boosted air purification. The mixing set is fixed to the fan casing by means of lock-latches to ensure easy removal for cleaning. Fan configuration with KFK mixing chamber provides cool air supply into the mixing chamber when the operating temperature exceeds 90°C. Such configuration also allows hot air withdrawal while the fan motor is not running.

**GFK** – gravitation backdraft damper to prevent air back draft in the system. Such fan configuration that includes KFK mixing set and GFK backdraft damper ensures fan motor overheating protection based on BY-PASS actuation, in particular when the motor is not running due to no power supply. The fans with such configuration enable backdraft damper shutting and hot air distribution to other premises through ventilation ducts when the motor is not running.

Designation key: \_\_\_\_\_

Fan series	Duct connection diameter	Motor	Modifications
<b>VENTS KAM</b>	125; 140; 150; 160	<b>Eco</b> – with external rotor; <b>EcoDuo</b> – two-speed with external rotor	_ – is equipped with temperature regulator by default; T1 – without temperature regulator

Accessories



page 305    page 305

Accessories



MKF    FFK    KFK    GFK    TS-1-90

1

**KAM, KAM Eco and KAM EcoDuo fans operation principle.**



**KAM, KAM Eco,  
KAM EcoDuo**

When the temperature in the fireplace hood reaches the set value the fan turns automatically on and distributes hot air from the fire hood place to other premises. It turns off when the temperature falls down below the set value.

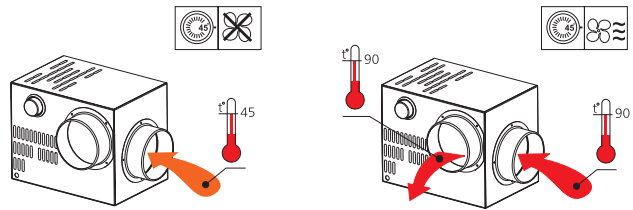

2

**Operation principle of KAM fan with FFK box filter**



**KAM**

**FFK**

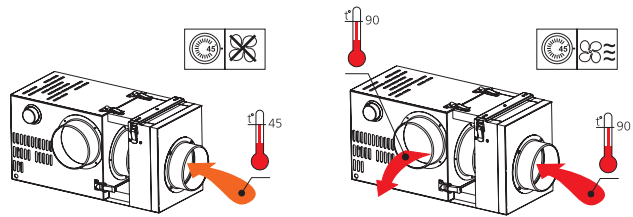

When the temperature in the fireplace hood reaches the set value the fan turns automatically on and distributes the hot air purified by FFK filter from the fire hood to other rooms. It turns off when the temperature falls down below the set value.

3

**Operation principle of KAM fan with KFK damper**

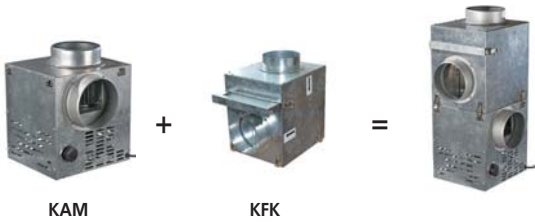

**KAM**

**KFK**

When the temperature in the fireplace hood reaches the set value the fan turns automatically on and distributes hot air from the fire hood place to other rooms. It turns off when the temperature falls below the set value. The fan with KFK mixing set provides additional hot air supply of hot air to the mixing chamber when the temperature of distributed air exceeds 90°C and as well as the withdrawal of the hot air when the motor is not running.

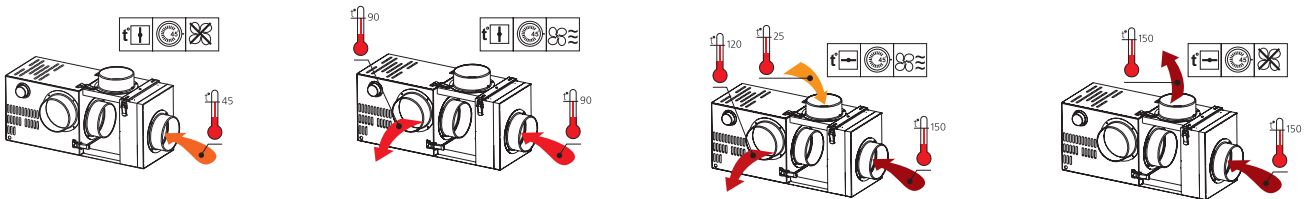

4

**Operation principle of KAM fan with KFK damper and GFK backdraft damper with BY-PASS system**



**KAM**

**KFK**

**GFK**

When the temperature in the fireplace hood reaches the set value the fan turns automatically on and distributes hot air from the fire hood place to other premises. It turns off when the temperature falls below the set value. **BY-PASS** system ensures overheating protection, i.e. the fan does not operate at no power supply. It closes the damper and boosts hot air through the opened gap to other premises. BY-PASS regulates the temperature by mixing chamber damper opening providing the cold air supply if the air supplied to the fan is too hot.

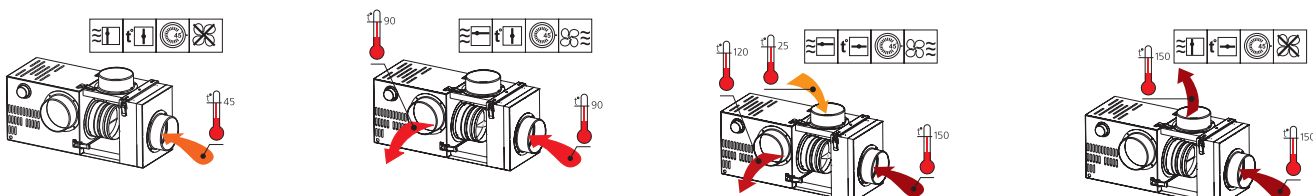

# CHIMNEY CENTRIFUGAL FANS

Installation and operation of KAM fans, KAM fans with FFK filter in the chimney system.

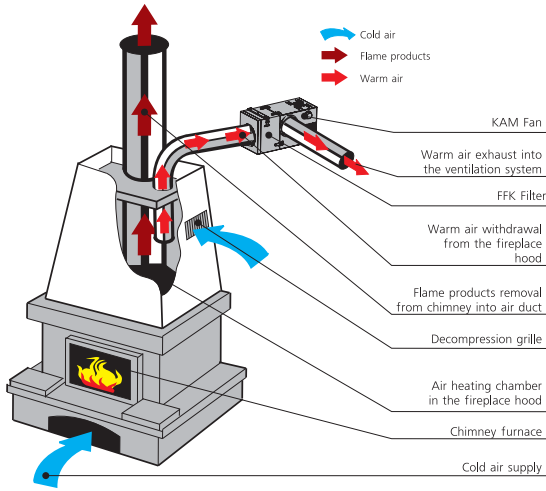

Installation and operation of KAM fans with KFK damper, KAM fans with KFK and GFK dampers with BY-PASS system in the chimney system

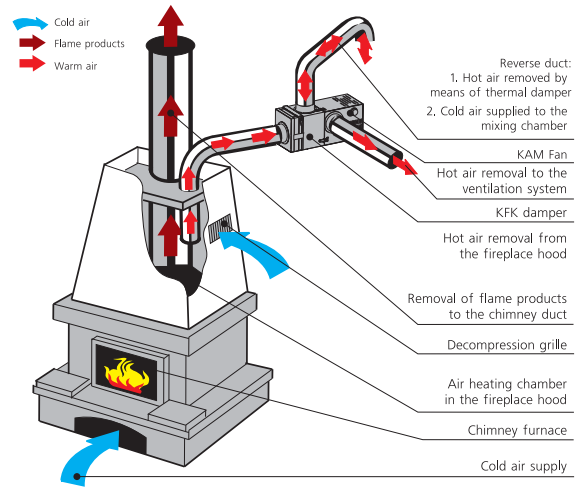

## Fan overall dimensions:

Type	Dimensions [mm]						Mass [kg]
	∅D	B	H	H1	L	P	
KAM 125	124	245	350	300	260	50	4,5
KAM 140	139	285	350	300	300	50	5,7
KAM 150	149	285	350	300	300	50	5,7
KAM 160	159	285	350	300	300	50	5,7
KAM 125 Eco KAM 125 EcoDuo	124	245	320	270	260	50	5,6
KAM 140 Eco KAM 140 EcoDuo	139	285	320	270	300	50	6,8
KAM 150 Eco KAM 150 EcoDuo	149	285	320	270	300	50	6,8
KAM 160 Eco KAM 160 EcoDuo	159	285	320	270	300	50	6,8

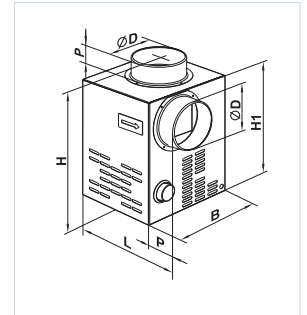

## Overall dimensions of fans with additional equipment:

Fan type	Additional equipment	Dimensions [mm]						Mass [kg]
		∅D	B	H	H1	L	P	
KAM 125	FFK	124	245	530	480	260	50	6,7
KAM 140	FFK	139	285	540	490	300	50	8,7
KAM 150	FFK	149	285	540	490	300	50	8,7
KAM 160	FFK	159	285	540	490	300	50	8,7
KAM 125 Eco KAM 125 EcoDuo	FFK	124	245	500	450	260	50	7,8
KAM 140 Eco KAM 140 EcoDuo	FFK	139	285	510	460	300	50	9,8
KAM 150 Eco KAM 150 EcoDuo	FFK	149	285	510	460	300	50	9,8
KAM 160 Eco KAM 160 EcoDuo	FFK	159	285	510	460	300	50	9,8

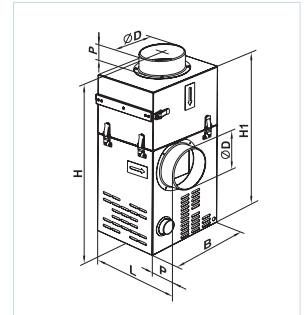

Type	Additional equipment	Dimensions [mm]						Mass [kg]
		∅D	B	H	H1	L	P	
KAM 125	KFK / KFK+GFK	124	245	610	560	260	50	8,3
KAM 140	KFK / KFK+GFK	139	285	650	600	300	50	9,7
KAM 150	KFK / KFK+GFK	149	285	650	600	300	50	9,7
KAM 160	KFK / KFK+GFK	159	285	650	600	300	50	9,7
KAM 125 Eco KAM 125 EcoDuo	KFK / KFK+GFK	124	245	580	530	260	50	9,4
KAM 140 Eco KAM 140 EcoDuo	KFK / KFK+GFK	139	285	620	570	300	50	10,8
KAM 150 Eco KAM 150 EcoDuo	KFK / KFK+GFK	149	285	620	570	300	50	10,8
KAM 160 Eco KAM 160 EcoDuo	KFK / KFK+GFK	159	285	620	570	300	50	10,8

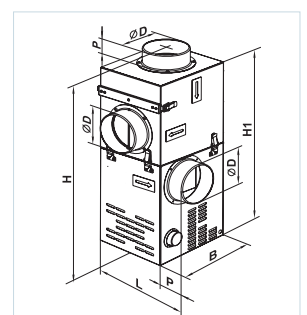



**Technical data:**

	KAM 125	KAM 140	KAM 150	KAM 160
Voltage [V / 50 Hz]	1~ 230	1~ 230	1~ 230	1~ 230
Power [W]	108	110	115	116
Current [A]	0,81	0,82	0,84	0,86
Maximum air flow [m³/h]	400	480	520	540
RPM [min <sup>-1</sup> ]	1300	1290	1280	1270
Noise level at 3 m [dBA]	42	42	42	42
Maximum operating temperature [°C]	150	150	150	150
Protection rating	IP X2	IP X2	IP X2	IP X2

**Technical data:**

	KAM 125 Eco	KAM 140 Eco	KAM 150 Eco	KAM 160 Eco
Voltage [V / 50 Hz]	1~ 230	1~ 230	1~ 230	1~ 230
Power [W]	32	41	43	44
Current [A]	0,14	0,18	0,19	0,19
Maximum air flow [m³/h]	350	420	450	470
RPM [min <sup>-1</sup> ]	1335	1250	1165	1110
Noise level at 3 m [dBA]	37	38	39	39
Maximum operating temperature [°C]	150	150	150	150
Protection rating	IP X2	IP X2	IP X2	IP X2

**Technical data:**

	KAM 125 EcoDuo		KAM 140 EcoDuo		KAM 150 EcoDuo		KAM 160 EcoDuo	
	min.	max.	min.	max.	min.	max.	min.	max.
Speed	1~ 230		1~ 230		1~ 230		1~ 230	
Voltage [V / 50 Hz]	1~ 230		1~ 230		1~ 230		1~ 230	
Power [W]	26	32	32	41	34	43	35	44
Current [A]	0.12	0.14	0.14	0.18	0.15	0.19	0.15	0.19
Maximum air flow [m³/h]	265	350	340	420	360	450	375	470
RPM [min <sup>-1</sup> ]	1210	1335	1180	1250	1075	1165	1040	1110
Noise level at 3 m [dBA]	29	37	31	38	31	39	32	39
Maximum operating temperature [°C]	150		150		150		150	
Protection rating	IP X2		IP X2		IP X2		IP X2	

**External temperature regulator TS-1-90**  
for chimney fans VENTS KAM T1,  
VENTS KAM Eco T1, VENTS KAM  
EcoDuo T1

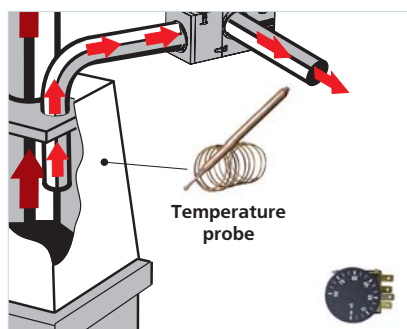

**Applications**

The temperature regulator is designed for chimney fan control and applied for hot air distribution from chimney to the premises.

**Design and control**

The temperature regulator casing is made of metal and equipped with the temperature control knob. The casing is connected with the temperature probe by means of a capillary tube of 1 m length. The temperature level is followed by the temperature probe which is installed directly inside the fireplace heat-exchanger. The temperature regulator controls

the fan operation and switches the chimney fan on or off depending on the set temperature increase or decrease.

**Mounting**

The temperature regulator is mounted in the concealed or external mounting box. The temperature probe is installed inside the fireplace heat-exchanger. The temperature regulator shall be installed away from the source of air heating. The wiring diagram for the controller is no. 31, 32 (refer the section «Wiring Diagrams»).

**Technical data:**

	TS-1-90
Voltage [V/50/60 Hz]	1~ 230
Maximum load current [A]	2,2 A
Maximum fan power [W]	500
Range of controllable temperatures [°C]	0...+90
Overall dimensions of the thermostat casing, [mm]	55 x 56 x 56
Capillary tube length [mm]	1000
Temperature probe	Ø 6,5 x 95 mm
Maximum ambient temperature for the casing [°C]	+80
Maximum temperature for the temperature probe and capillary tube [°C]	+150° C
Protection rating	IP40



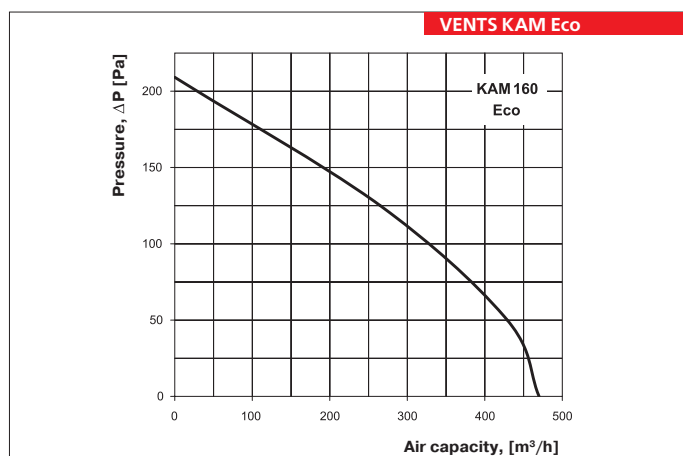
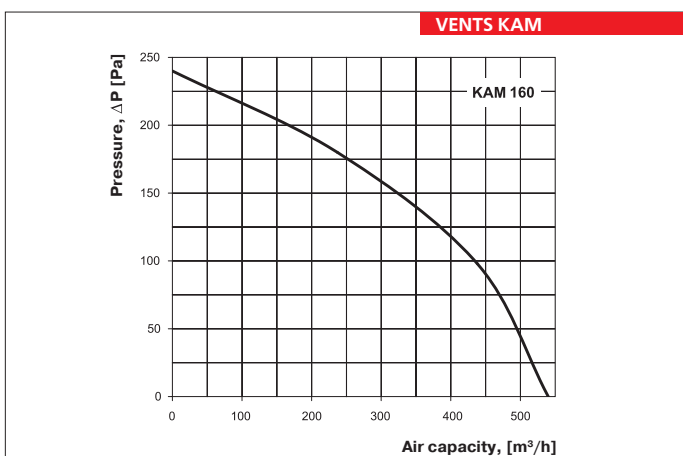
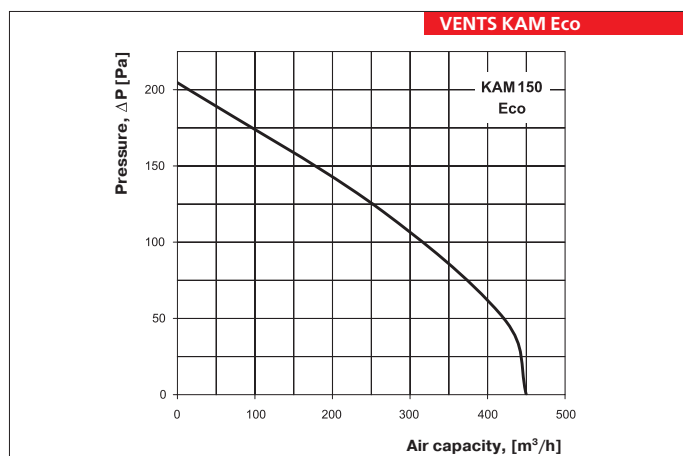
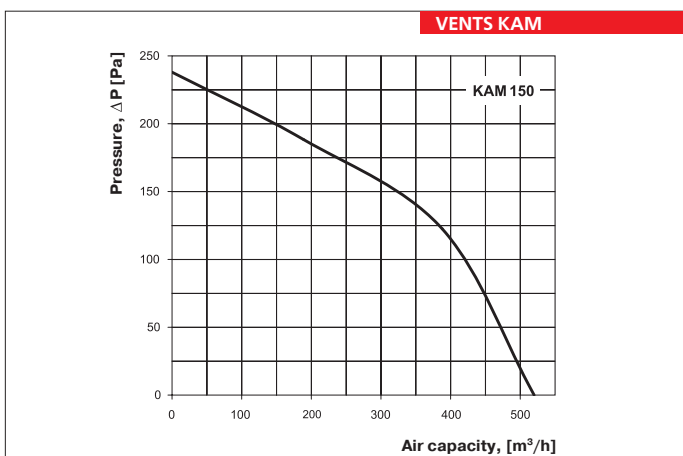
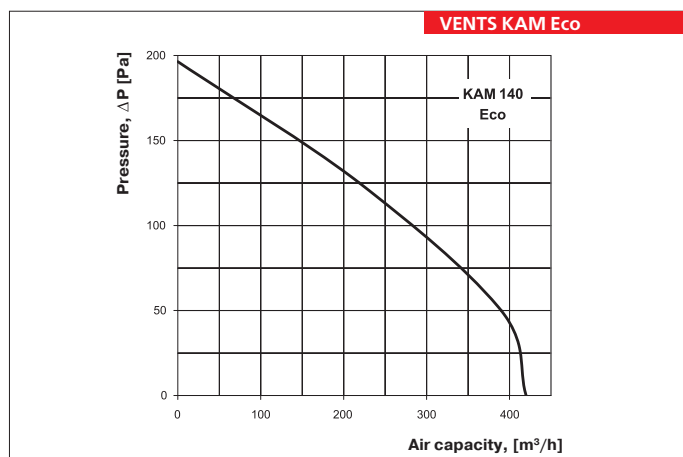
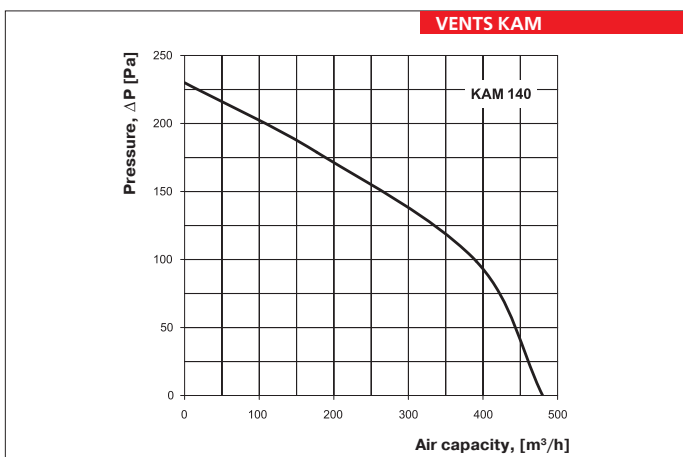
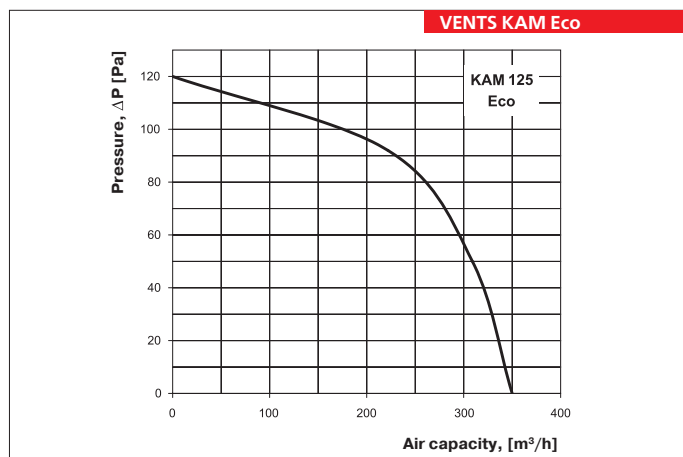
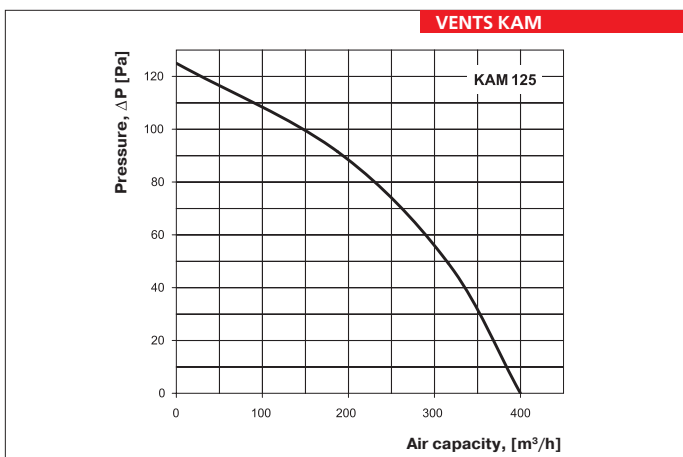

ELECTRICAL ACCESSORIES COMPATIBILITY

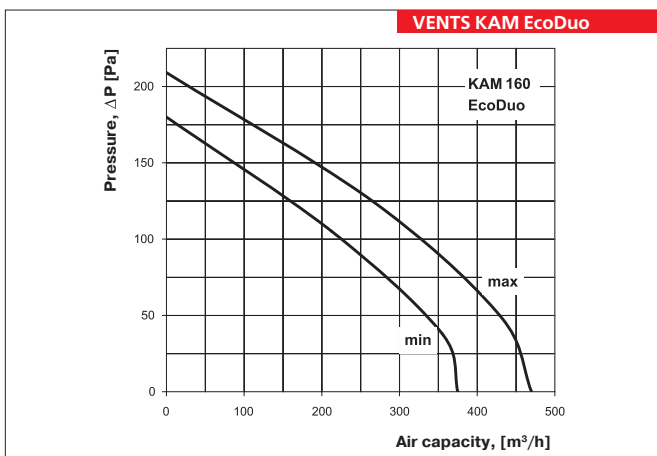
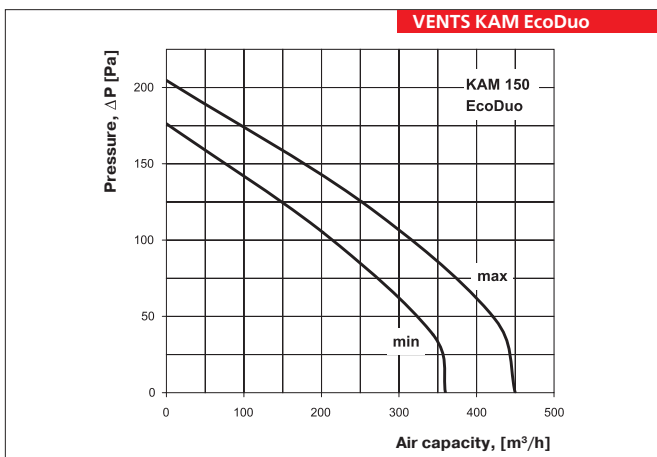
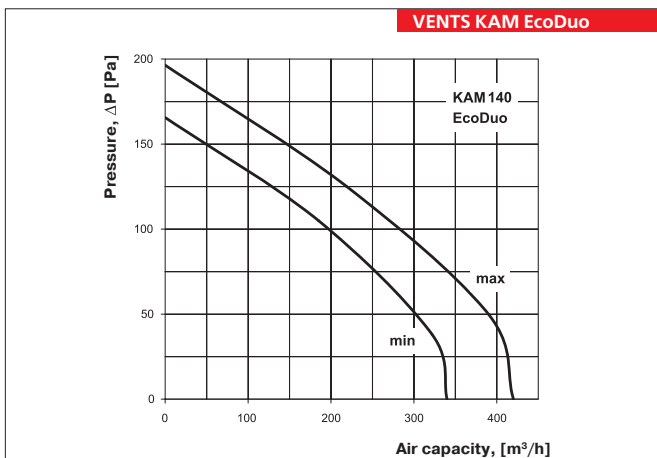
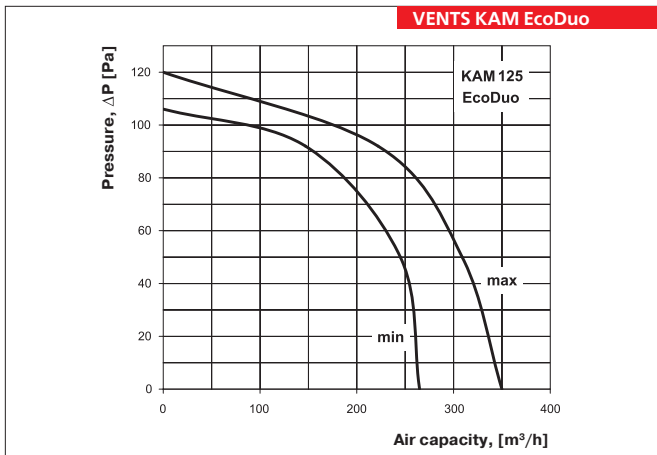

		KAM 125	KAM 140	KAM 150	KAM 160	KAM 125 Eco	KAM 140 Eco	KAM 150 Eco	KAM 160 Eco	KAM 125 EcoDuo	KAM 140 EcoDuo	KAM 150 EcoDuo	KAM 160 EcoDuo
<b>Thyristor speed controllers</b>													
	RS-1-300	•	•	•	•	•	•	•	•				
	RS-1-400	•	•	•	•	•	•	•	•				
	RS-1 N (V)	•	•	•	•	•	•	•	•				
	RS-1,5 N (V)	•	•	•	•	•	•	•	•				
	RS-2 N (V)	•	•	•	•	•	•	•	•				
	RS-2,5 N (V)	•	•	•	•	•	•	•	•				
	RS-0,5-PS					•	•	•	•				
	RS-1,5-PS	•	•	•	•								
	RS-2,5-PS	•	•	•	•								
	RS-4,0-PS	•	•	•	•								
	RS-1,5-T	•	•	•	•								
	RS-3,0-T	•	•	•	•								
	RS-5,0-T	•	•	•	•								
	RS-10,0-T												
	RS-1,5-TA	•	•	•	•								
	RS-3,0-TA	•	•	•	•								
	RS-5,0-TA	•	•	•	•								
	RS-10,0-TA												
<b>Transformer speed controllers</b>													
	RSA5E-2-P	•	•	•	•	•	•	•	•				
	RSA5E-2-M	•	•	•	•	•	•	•	•				
	RSA5E-3-M	•	•	•	•	•	•	•	•				
	RSA5E-4-M	•	•	•	•	•	•	•	•				
	RSA5E-12-M	•	•	•	•	•	•	•	•				
	RSA5E-1,5-T	•	•	•	•	•	•	•	•				
	RSA5E-3,5-T	•	•	•	•	•	•	•	•				
	RSA5E-5,0-T	•	•	•	•	•	•	•	•				
	RSA5E-8,0-T	•	•	•	•	•	•	•	•				
	RSA5E-10,0-T	•	•	•	•	•	•	•	•				
	RSA5D-1,5-T												
	RSA5D-3,5-T												
	RSA5D-5-M												
	RSA5D-8-M												
	RSA5D-10-M												
	RSA5D-12-M												
<b>Frequency speed controllers</b>													
	VFED-200-TA												
	VFED-400-TA												
	VFED-750-TA												
	VFED-1100-TA												
	VFED-1500-TA												
<b>Temperature regulators</b>													
	RTS-1-400									•	•	•	•
	RTSD-1-400									•	•	•	•
	RT-10	•	•	•	•	•	•	•	•	•	•	•	•
<b>Multi-speed fan switches</b>													
	P2-5,0									•	•	•	•
	P3-5,0												
	P5-5,0												
	P2-1-300									•	•	•	•
	P3-1-300												
<b>EC-motors controllers</b>													
	R-1/010												
<b>Sensors</b>													
	T-1,5 N	•	•	•	•	•	•	•	•	•	•	•	•
	TH-1,5 N	•	•	•	•	•	•	•	•	•	•	•	•
	TF-1,5 N	•	•	•	•	•	•	•	•	•	•	•	•
	TP-1,5 N	•	•	•	•	•	•	•	•	•	•	•	•

• recommended  
• suitable

FAN SERIES VENTS KAM

# SOUND-INSULATED FANS

## ▶ VENTS VS



- ▶ In-line centrifugal sound- and heat-insulated duct fans with back-curved impeller blades and the air capacity up to 16870 m<sup>3</sup>/h. Applied for supply and exhaust ventilation systems for premises with high requirements to noise level. Compatible with round and rectangular air ducts.

## ▶ VENTS KSA



- ▶ Compact sound- and heat-insulated centrifugal fans with forward-curved impeller blades and the air capacity up to 1500 m<sup>3</sup>/h. Applied in supply and exhaust ventilation systems for premises with high requirements to noise level. Compatible with Ø 100, 125, 150, 160, 200 and 250 mm round ducts.

## ▶ VENTS KSB



- ▶ Compact in-line sound- and heat-insulated centrifugal fans with back-curved impeller blades and the air capacity up to 2150 m<sup>3</sup>/h. Designed for supply and exhaust ventilation systems for premises with high requirements to noise level. Compatible with Ø 100, 125, 150, 160, 200, 250 and 315 mm round ducts.

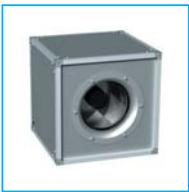

**VENTS VS**  
**sound-insulated fan**

Air capacity – up to 16870 m<sup>3</sup>/h

page  
94

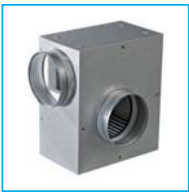

**VENTS KSA**  
**sound-insulated fan**

Air capacity – up to 1500 m<sup>3</sup>/h

page  
100



**VENTS KSB**  
**sound-insulated fan**

Air capacity – up to 2150 m<sup>3</sup>/h

page  
104

Series  
**VENTS VS**



Inline centrifugal duct fans in heat- and sound-insulated casing with the air capacity up to **16 870 m<sup>3</sup>/h**

■ **Applications**

Supply and exhaust ventilation systems for various premises with high noise level requirements. The unique fan design ensures changing the position of the side panels as well the position of the panel with the exhaust branch pipe that supplies air in all directions both linearly and at the angle of 90°. Such design enables assembling various ventilation system configurations depending on a project. VS fans can be used as a separate part of an assembled supply unit. Due to the galvanized-steel casing and heat insulation the fans are suitable for outdoor mounting.

■ **Design**

The fan casing is made of aluminum frame fixed with angles and removable heat- and sound-insulated double layer panels of galvanized steel. 25 mm noncombustible mineral wool layer is applied for the panel insulation. Round connecting pipes are equipped with rubber seals. **Connecting air ducts are not included into delivery set and are ordered separately!**

■ **Motor**

The centrifugal impeller with galvanized steel back-curved blades is powered by means of 2-, 4- or 6-pole asynchronous motor with external rotor. For thermal

overheating protection thermal contacts with leaded outside terminals are built in the motor for connection to the external protection devices and VS 355-4E model is equipped with overheating protection with automatic restart. Due to the motor ball bearings with selective lubricating the fan operation is low-noise and maintenance-free.

■ **Speed control**

Both smooth or step speed control is performed with the thyristor or autotransformer controller. Speed is controlled by means of power voltage decrease. Air capacity as a function of motor speed. Several fans can be connected to one controller in case their total power and operating current do not exceed the controller rated values.

■ **Mounting**

In-line fans are designed for mounting into rectangular ducts. In case of connection through the flexible connectors the fan is fixed to a building by means of supports, suspension brackets or fixation brackets. The fans can be mounted in any position with respect to the airflow direction which is indicated with a pointer on the casing. Access for the fan maintenance shall be provided.



VS series fan with VPG connecting reducers.

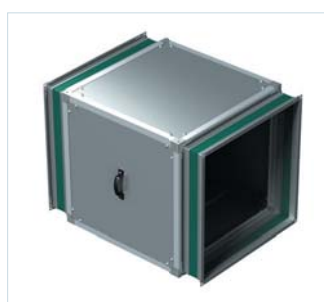

VS fan with VVG flexible ant-vibration flexible connectors



Designation key: \_\_\_\_\_

Fan series
<b>VENTS VS</b>

Impeller diameter	
355; 400; 450; 500; 560; 630; 710	S - high-powered motor

Motor	
Polarity	Phase
4, 6	E - single phase D - three phases

Accessories



page 311

page 312

page 313

page 315

page 316

page 317

page 318

page 319

Offered options for fans

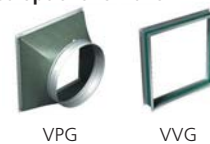

VPG

VVG



**Technical data:**

	VS 355-4E	VS 355-4D	VS 400-4E	VS 400-4D	
Voltage [V/50/60 Hz]	1~ 230	3~ 400	1~ 230	3~ 400 Δ	3~ 400 Y
Power [W]	245	230	480	515	385
Current [A]	1,12	0,52	2,40	1,41	0,70
Max. air capacity [m <sup>3</sup> /h] with the air flow:	2890	2660	3750	3950	3340
- straight forward	2650	2380	3535	3740	3110
RPM [min <sup>-1</sup> ]	1420	1400	1370	1415	1235
Noise level at 3 m [dBA]	54	53	51	51	47
Maximum operating temperature [°C]	-25 +50	-25 +70	-40 +80	-40 +60	-40 +80
Protection rating	IP X4	IP X4	IP X4	IP X4	

**Technical data:**

	VS 450-4E	VS 450-4D	VS 500-4E	VS 500-4D	VS 560-4D
Voltage [V/50/60 Hz]	1~ 230	3~ 400	1~ 230	3~ 400	3~ 400
Power [W]	680	740	1300	1430	2380
Current [A]	3,00	1,50	5,70	3,00	5,00
Max. air capacity [m <sup>3</sup> /h] with the air flow:	5630	5700	7330	7940	11340
- straight forward	4930	5080	6680	7200	10490
RPM [min <sup>-1</sup> ]	1250	1350	1320	1375	1365
Noise level at 3 m [dBA]	53	54	55	58	56
Maximum operating temperature [°C]	-40 +70	-40 +80	-20 +50	-40 +80	-40 +60
Protection rating	IP X4	IP X4	IP X4	IP X4	IP X4

**Technical data:**

	VS 560-6D	VS 630-4D	VS 630C-4D	VS 630-6D	VS 710-6D
Voltage [V/50/60 Hz]	3~ 400	3~ 400	3~ 400	3~ 400	3~ 400
Power [W]	780	3310	4250	1310	2000
Current [A]	1,70	6,20	7,55	2,80	3,90
Max. air capacity [m <sup>3</sup> /h] with the air flow:	7970	15170	16870	12030	15830
- straight forward	7330	13740	14930	10440	14880
RPM [min <sup>-1</sup> ]	885	1170	1300	880	890
Noise level at 3 m [dBA]	49	67	69	55	59
Maximum operating temperature [°C]	-40 +55	-40 +35	-40 +60	-40 +60	-20 +40
Protection rating	IP X4	IP X4	IP X4	IP X4	IP X4

**Fan and additional equipment overall dimensions:**

Type	Dimensions [mm]		Mass [kg]	Offered options for fans		Dimensions [mm]			
	A			VPG	VVG	A	B	C	∅D
VS 355-4E	500		25	VPG 500/355	VVG 500x500	490	470	445	355
VS 355-4D	500		25						
VS 400-4E	670		39	VPG 670/400	VVG 670x670	660	640	615	400
VS 400-4D	670		39						
VS 450-4E	670		43	VPG 670/450	VVG 670x670	660	640	615	450
VS 450-4D	670		43						
VS 500-4E	670		52	VPG 670/500	VVG 670x670	660	640	615	500
VS 500-4D	670		56						
VS 560-4D	800		99	VPG 800/560	VVG 800x800	790	770	745	560
VS 560-6D	800		86						
VS 630-4D	800		102	VPG 800/630	VVG 800x800	790	770	745	630
VS 630C-4D	800		100						
VS 630-6D	800		98						
VS 710-6D	1000		136	VPG 1000/710	VVG 1000x1000	990	970	945	710

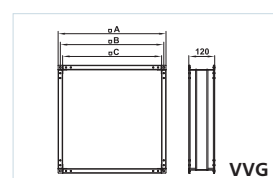
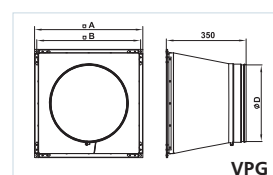
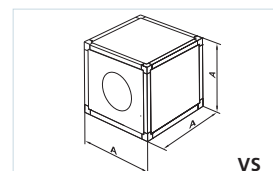

VENTS VS

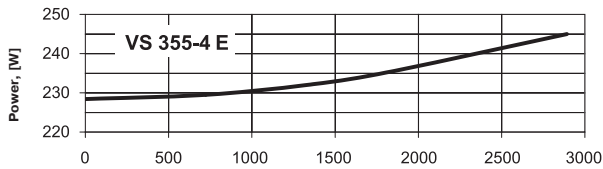
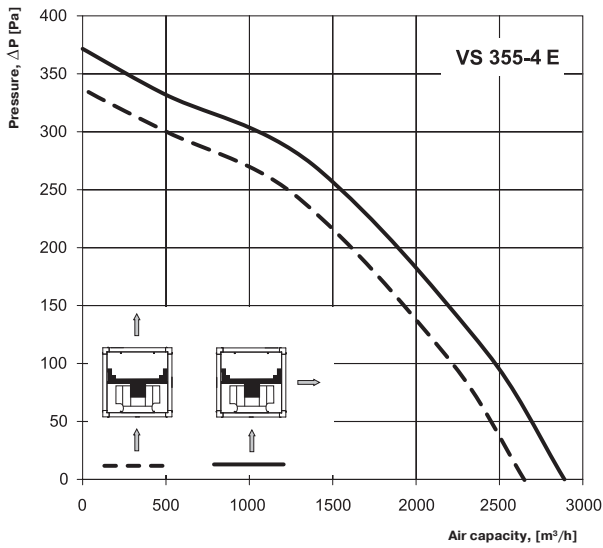

Sound-power level	Hz	Gen	Octave-frequency band [Hz]							
			63	125	250	500	1000	2000	4000	8000
$L_{WA}$ to inlet	dBA	70	55	58	61	63	62	60	52	47
$L_{WA}$ to outlet	dBA	68	57	59	62	65	63	62	55	47
$L_{WA}$ to environment	dBA	62	51	51	54	58	55	55	48	40

VENTS VS

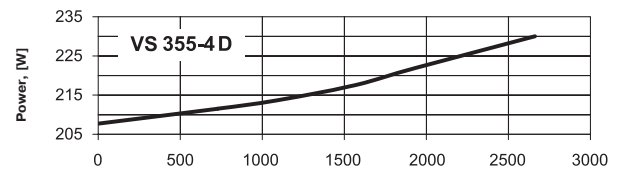
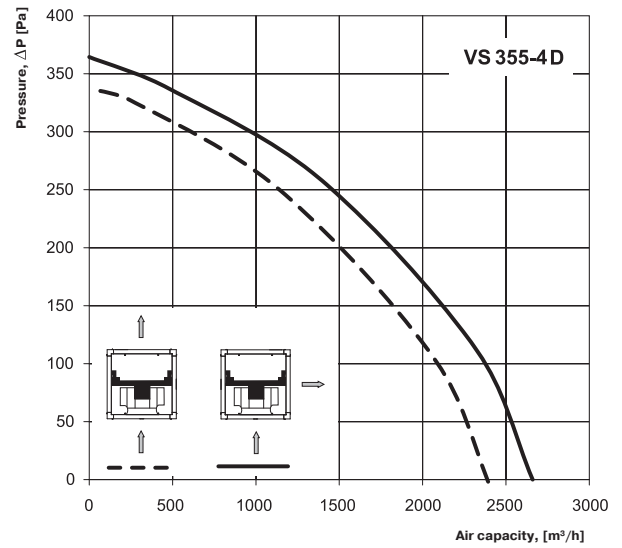

Sound-power level	Hz	Gen	Octave-frequency band [Hz]							
			63	125	250	500	1000	2000	4000	8000
$L_{WA}$ to inlet	dBA	68	54	57	61	63	62	59	52	46
$L_{WA}$ to outlet	dBA	70	55	61	61	65	66	59	54	47
$L_{WA}$ to environment	dBA	64	49	50	55	59	56	52	49	39

VENTS VS

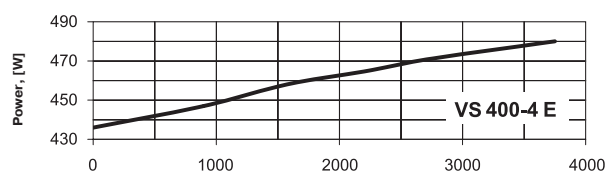
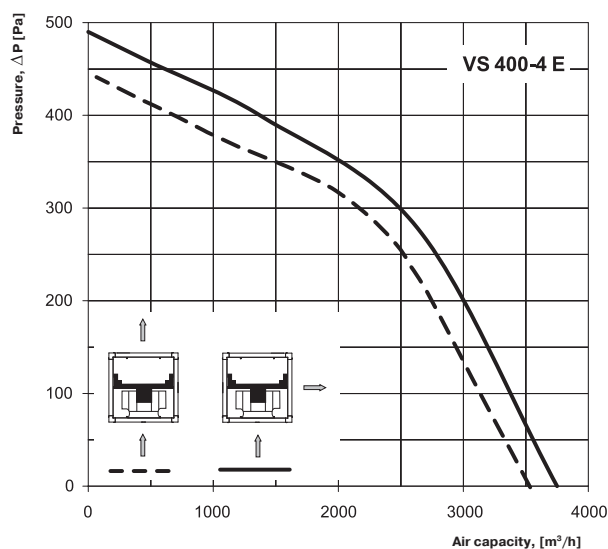

Sound-power level	Hz	Gen	Octave-frequency band [Hz]							
			63	125	250	500	1000	2000	4000	8000
$L_{WA}$ to inlet	dBA	72	60	62	66	66	64	65	58	51
$L_{WA}$ to outlet	dBA	74	61	63	68	71	68	67	58	53
$L_{WA}$ to environment	dBA	56	43	47	47	52	49	48	42	33

VENTS VS

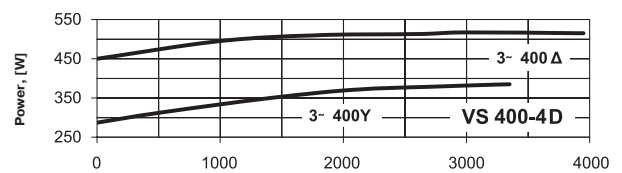
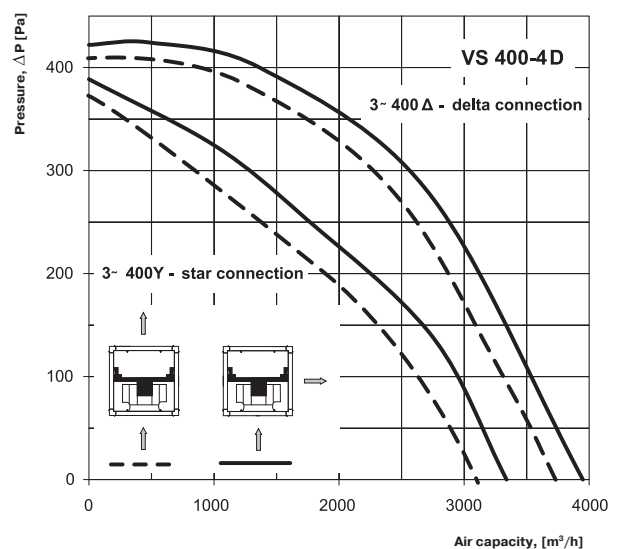

Sound-power level	Hz	Gen	Octave-frequency band [Hz]							
			63	125	250	500	1000	2000	4000	8000
$L_{WA}$ to inlet	dBA	73	57	63	64	67	68	62	59	52
$L_{WA}$ to outlet	dBA	74	60	63	65	69	66	67	61	51
$L_{WA}$ to environment	dBA	54	43	44	49	50	51	47	42	36

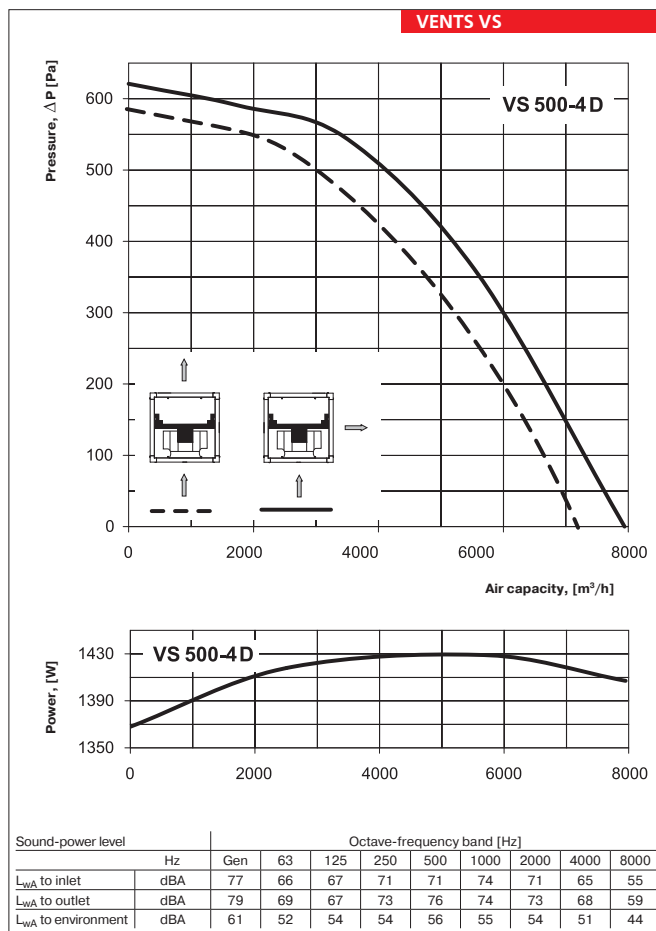
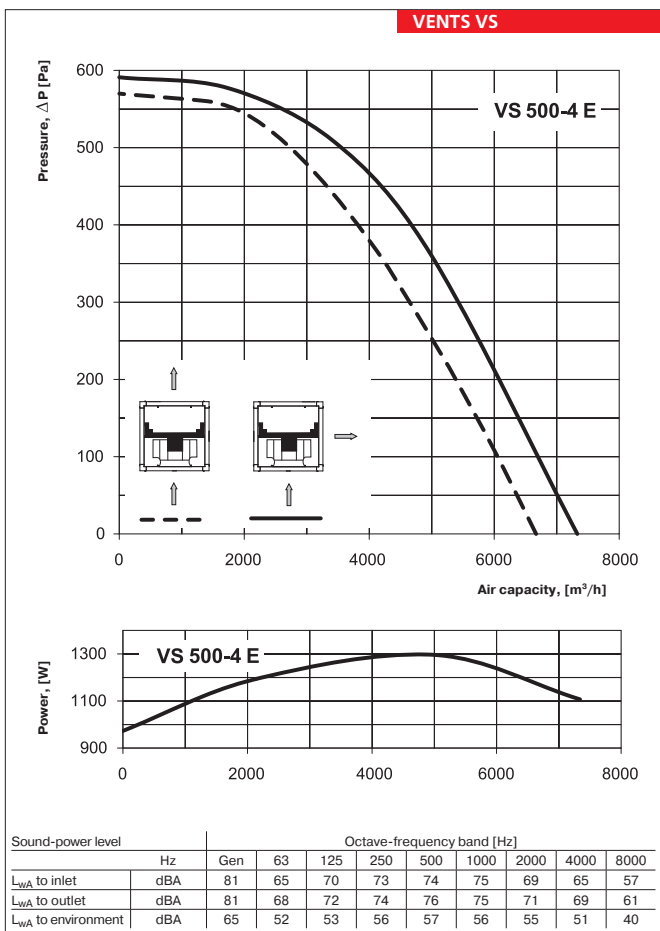
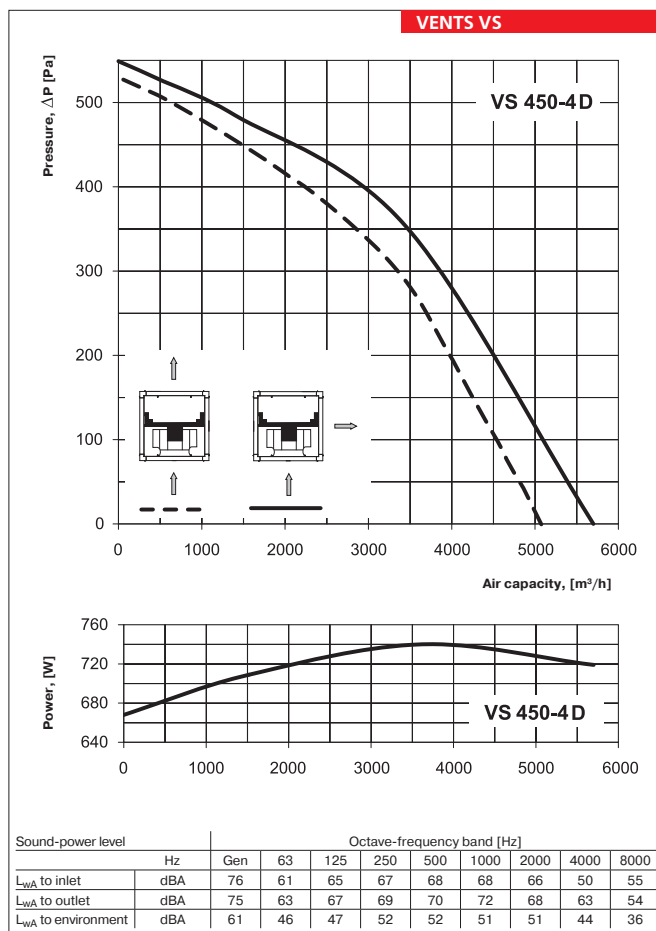
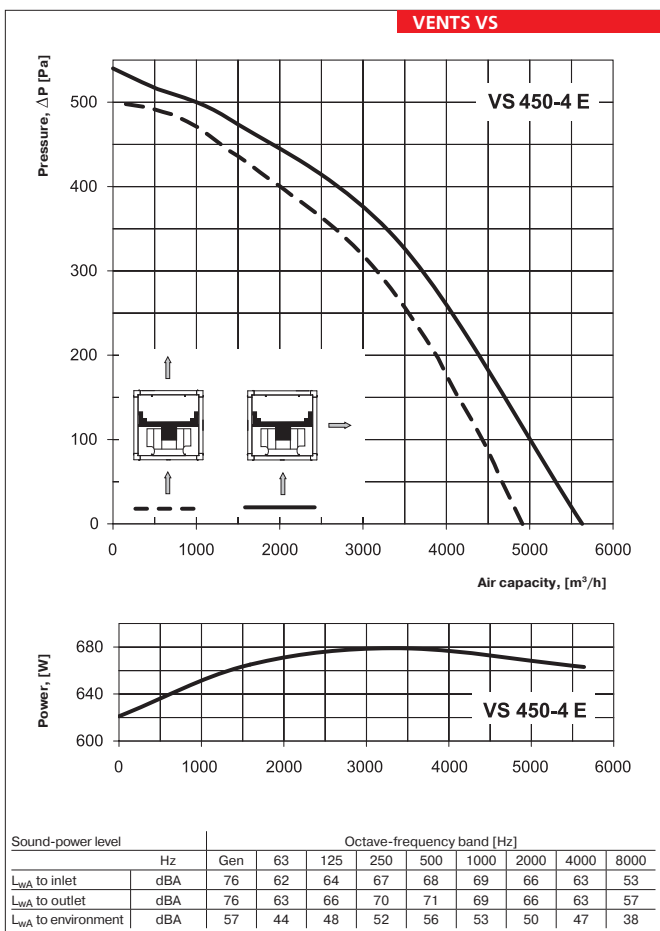

FAN SERIES VENTS VS

VENTS VS

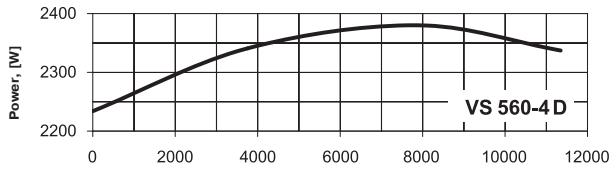
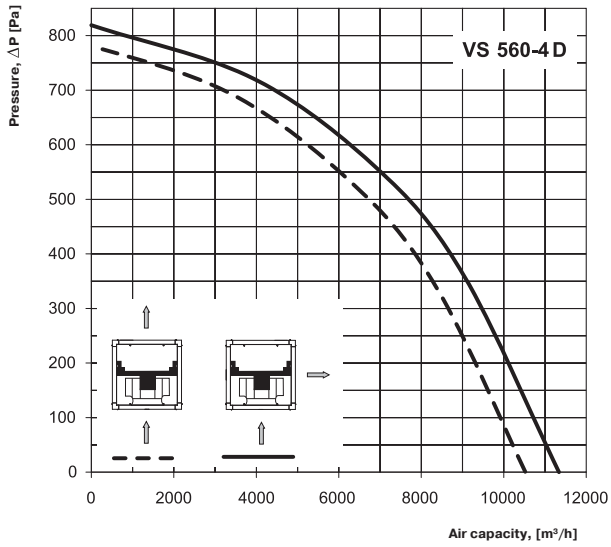

Sound-power level	Hz	Gen	Octave-frequency band [Hz]							
			63	125	250	500	1000	2000	4000	8000
$L_{WA}$ to inlet	dBA	80	66	67	73	75	73	69	67	58
$L_{WA}$ to outlet	dBA	80	67	71	73	77	74	73	65	61
$L_{WA}$ to environment	dBA	63	53	55	59	57	60	53	49	41

VENTS VS

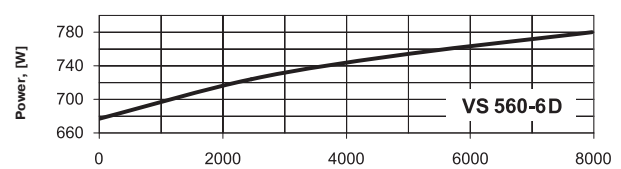
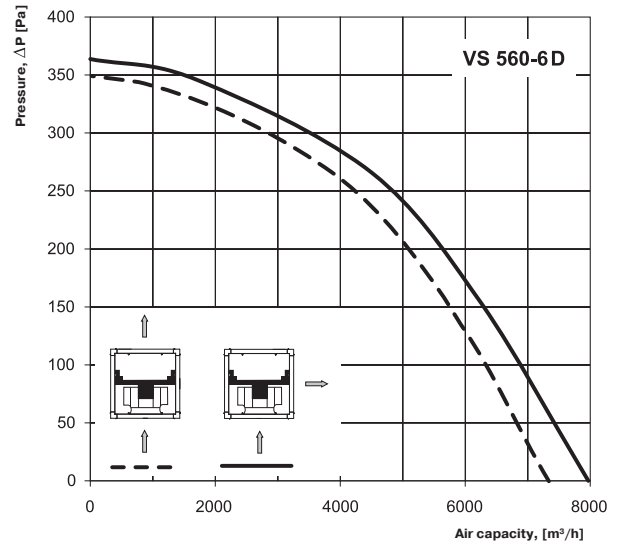

Sound-power level	Hz	Gen	Octave-frequency band [Hz]							
			63	125	250	500	1000	2000	4000	8000
$L_{WA}$ to inlet	dBA	72	59	57	64	67	67	62	56	49
$L_{WA}$ to outlet	dBA	70	58	61	66	68	65	65	60	51
$L_{WA}$ to environment	dBA	56	44	43	48	52	50	46	41	33

VENTS VS

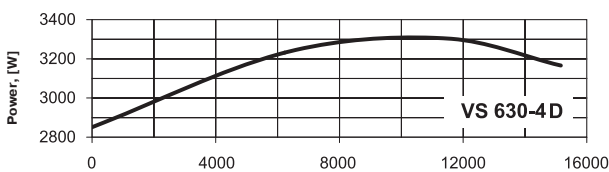
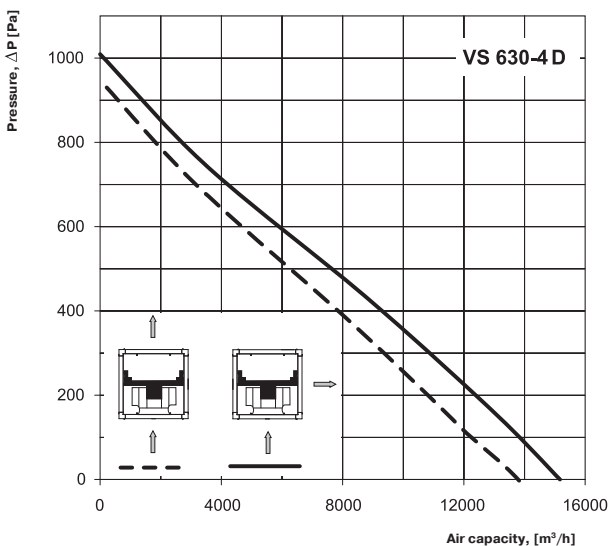

Sound-power level	Hz	Gen	Octave-frequency band [Hz]							
			63	125	250	500	1000	2000	4000	8000
$L_{WA}$ to inlet	dBA	85	76	78	80	80	83	78	75	68
$L_{WA}$ to outlet	dBA	88	76	76	84	86	82	78	67	67
$L_{WA}$ to environment	dBA	76	64	65	67	73	68	69	62	53

VENTS VS

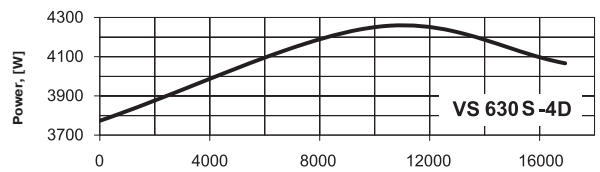
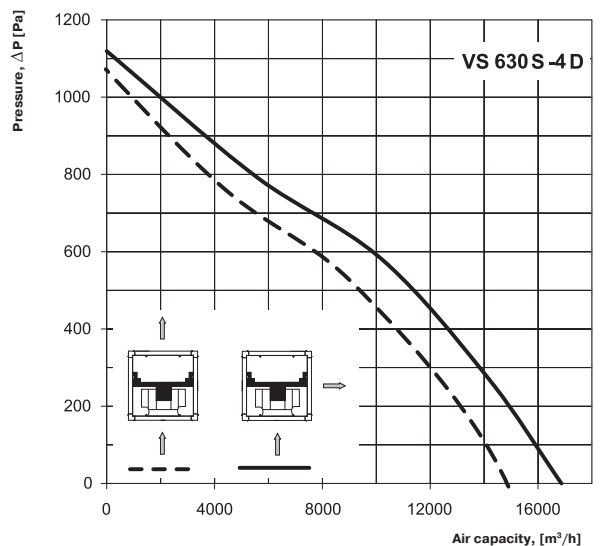

Sound-power level	Hz	Gen	Octave-frequency band [Hz]							
			63	125	250	500	1000	2000	4000	8000
$L_{WA}$ to inlet	dBA	85	76	77	81	83	82	77	72	68
$L_{WA}$ to outlet	dBA	89	77	78	81	85	84	80	73	68
$L_{WA}$ to environment	dBA	78	65	65	70	71	70	69	62	54

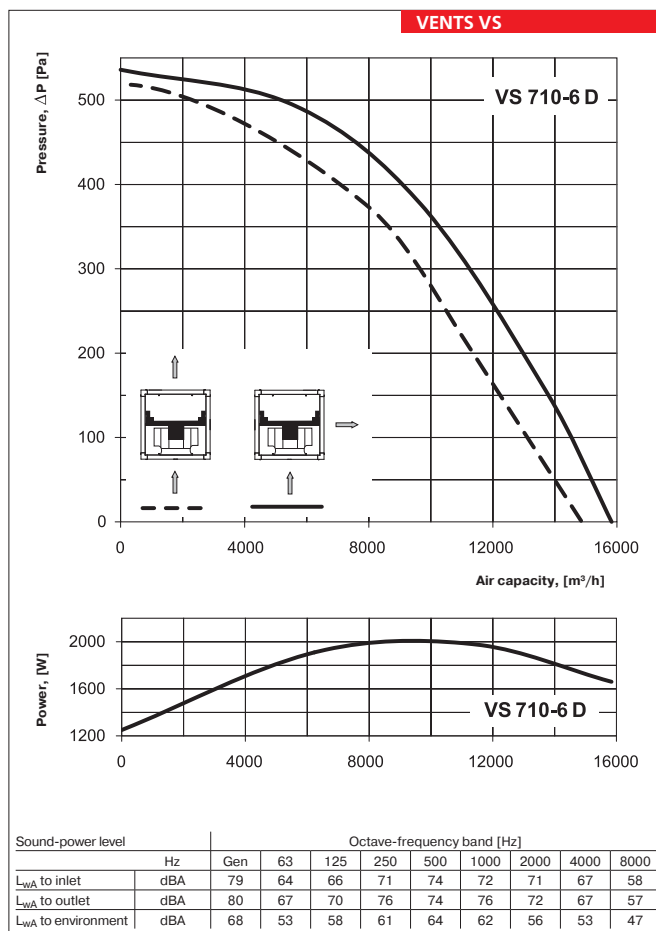
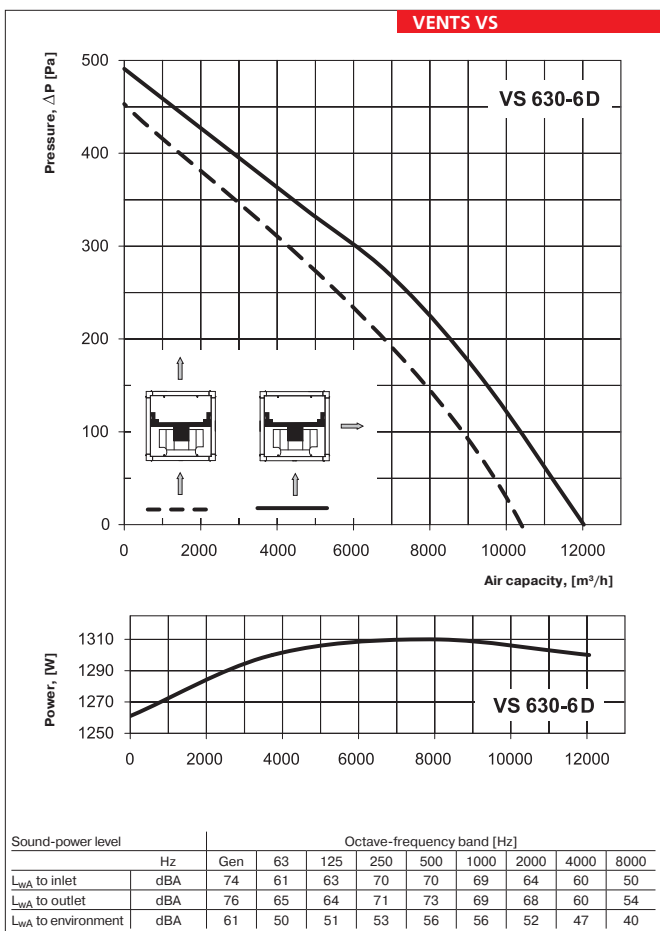

FAN SERIES

VENTS VS



VS fan gym ventilation example.



VS fan office ventilation example.



Series  
**VENTS KSA**



Centrifugal fans in heat- and sound-insulated casing with the air capacity up to **1500 m<sup>3</sup>/h**

■ **Applications**

KSA fan design enables their application in supply and exhaust ventilation systems for the premises with high noise level requirements. Suitable for connection with Ø 100, 125, 150, 160, 200 and 250 mm round ducts.

■ **Design**

The fan casing is made of aluzink. Heat- and sound-insulating layer is made of polystyrene foam.

■ **Motor**

The impeller made of galvanized steel and forward curved blades is powered by means of the 2- or 4-pole asynchronous motor with external rotor. The motor is equipped with the ball bearings for long service life. For precise features, safe operation and low noise, each impeller is dynamically balanced while assembly. Motor protection rating IP 44.

■ **Speed control**

Both smooth or step speed control is performed with the symistor or autotransformer controller. Several fans can be connected to one controller in case their total power and operating current do not exceed the controller rated values.

■ **Mounting**

Connection pipes have round section. The basic version of the fan includes the power cord with no plug. The power cord and C14 (KSA...R) plug can be supplied. Electric connection and mounting shall be performed in compliance with the operation manual and wiring diagram.

■ **KSA fan with electronic module for speed control with temperature sensor**

KSA fan with electronic module for temperature and speed is the perfect solution for greenhouses and other premises requiring air temperature control. Fans marked KSA...U fitted with TSC electronic speed control module with temperature sensor provide automatic

speed regulation as a function of air temperature in the duct. Temperature and minimum speed can be adjusted with two control knobs on the controller panel. The fan can be supplied with the external duct temperature sensor with 4 m cable and a cover for mechanical damage protection. The LED indicator for thermostat switching on is placed at the front panel of the fan.

■ **Automatic speed controller pattern for KSA fans.**

Set the desirable threshold temperature value for thermostat switching on by means of rotating the control knob. Normally the fan operates with the speed which is set with the knob. If the temperature exceeds the set point, the fan boosts to the maximum speed producing maximum air capacity. After that when the temperature drops down below the set point, the fan goes back to preset speed. The switching delay disables frequent motor switching (if the set temperature in the duct is equal to the threshold temperature).

There are two patterns of delay that may be used in various cases:

1. Temperature sensor delay (KSA...U): if the temperature rises by 2°C above the set threshold of thermostat actuation, the motor switches to the increased rotation speed. The motor switches to the preset (low) speed as the temperature drops below the set threshold of thermostat switching on. This pattern may be used to keep air temperature to within 2°C. In this case fan switches are rare.

2. Timer delay (KSA...U1): the motor sets to higher speed 5 min after the temperature exceeds the set threshold. The motor switches to the preset (low) speed 5 min. after the temperature drops below the set threshold.

This pattern can be used to keep the air temperature at a precise level. In this case the fan switches more frequently than in the pattern of temperature sensor delay, but the intervals do not exceed 5 minutes.

**Designation key:**

Fan series	Connecting pipe diameter	Motor		Options
		Polarity	Phase	
<b>VENTS KSA</b>	100; 125; 150; 160; 200; 250; 315	2, 4	E – single-phase	<b>R</b> – equipped with the power cord and plug; <b>U</b> – speed controller module with the built in temperature sensor; <b>Un</b> – speed controller module with the external temperature sensor; <b>U1</b> – speed controller with the built in timer and temperature sensor; <b>U1n</b> – speed controller with the built in timer and external temperature sensor.

**Accessories**



page 240   page 248   page 250   page 254   page 262   page 294   page 296   page 310   page 310   page 311   page 315   page 318

**Technical data:**

	KSA 100-2E	KSA 125-2E	KSA 150-2E
Voltage [V / 50 Hz]	230	230	230
Power [W]	115	120	260
Current [A]	0,51	0,52	1,16
Maximum air flow [m <sup>3</sup> /h]	400	530	730
RPM [min <sup>-1</sup> ]	2650	2650	2600
Noise level at 3 m [dBA]	36,1	38,3	39,4
Maximum operating temperature [°C]	-25 +40	-25 +40	-25 +40
Protection rating	IPX4	IPX4	IPX4

**Technical data:**

	KSA 160-2E	KSA 200-4E	KSA 250-4E	KSA 315-4E
Voltage [V / 50 Hz]	230	230	230	230
Power [W]	260	110	395	570
Current [A]	1,16	0,45	1,98	2,48
Maximum air flow [m <sup>3</sup> /h]	730	850	1500	2140
RPM [min <sup>-1</sup> ]	2600	1300	1330	1325
Noise level at 3 m [dBA]	37,9	29,1	35,5	43,7
Maximum operating temperature [°C]	-25 +40	-25 +40	-25 +40	-40 +55
Protection rating	IPX4	IPX4	IPX4	IPX4

**Fan overall dimensions:**

Type	Dimensions [mm]					Mass [kg]
	∅D	B	H	L	P	
KSA 100-2E	99	184	308	310	48	4,22
KSA 125-2E	123	204	308	310	48	4,57
KSA 150-2E	148	231	343	358	48	6,28
KSA 160-2E	158	231	343	358	48	6,28
KSA 200-4E	198	282	408	445	48	8,25
KSA 250-4E	248	330	500	525	48	10,50
KSA 315-4E	314	392	495	535	48	17,0

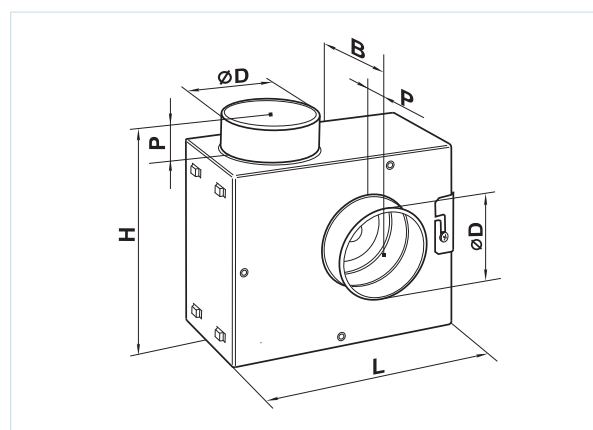

VENTS KSA

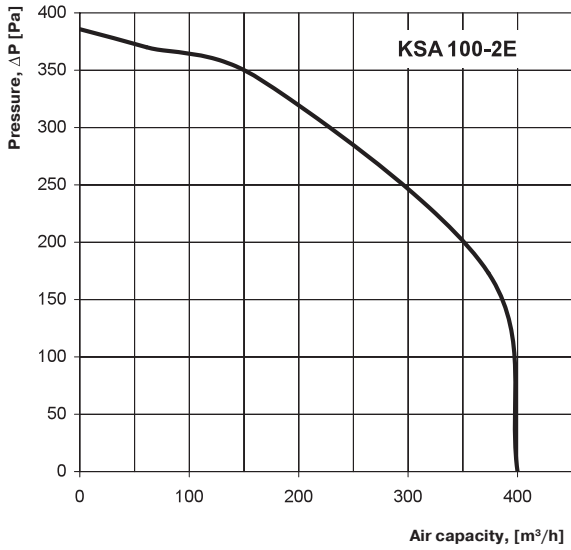

Sound-power level	Hz	Octave-frequency band [Hz]								
		Gen	63	125	250	500	1000	2000	4000	8000
$L_{WA}$ to inlet	dBA	47	44	41	42	37	35	35	30	29
$L_{WA}$ to outlet	dBA	50	45	41	41	37	35	31	30	28
$L_{WA}$ to environment	dBA	43	39	36	37	31	30	28	25	22

VENTS KSA

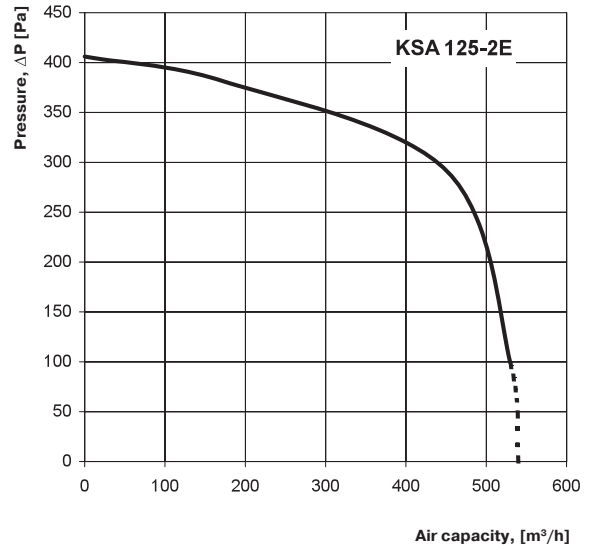

Sound-power level	Hz	Octave-frequency band [Hz]								
		Gen	63	125	250	500	1000	2000	4000	8000
$L_{WA}$ to inlet	dBA	48	45	44	46	37	39	33	30	25
$L_{WA}$ to outlet	dBA	50	45	43	47	39	39	33	29	27
$L_{WA}$ to environment	dBA	45	40	39	41	34	33	27	23	22

VENTS KSA

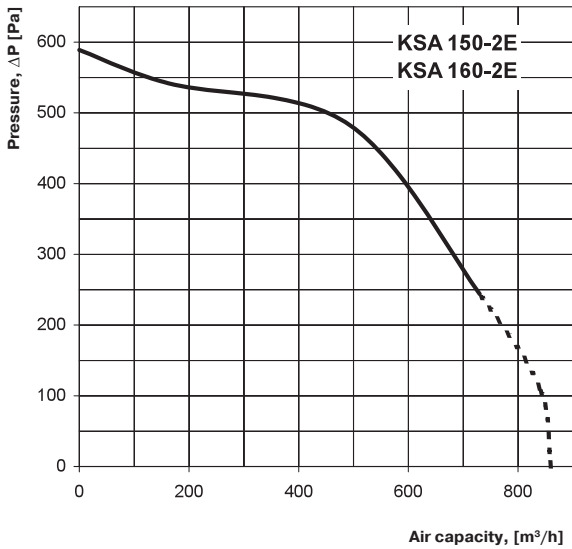

Sound-power level	Hz	Octave-frequency band [Hz]								
		Gen	63	125	250	500	1000	2000	4000	8000
$L_{WA}$ to inlet	dBA	55	42	52	50	40	35	28	25	21
$L_{WA}$ to outlet	dBA	55	43	51	48	40	34	29	23	23
$L_{WA}$ to environment	dBA	50	39	48	44	35	30	25	20	17

Sound-power level	Hz	Octave-frequency band [Hz]								
		Gen	63	125	250	500	1000	2000	4000	8000
$L_{WA}$ to inlet	dBA	56	44	51	48	38	33	29	24	22
$L_{WA}$ to outlet	dBA	54	42	51	50	37	31	30	25	25
$L_{WA}$ to environment	dBA	49	37	47	43	34	28	25	20	18

VENTS KSA

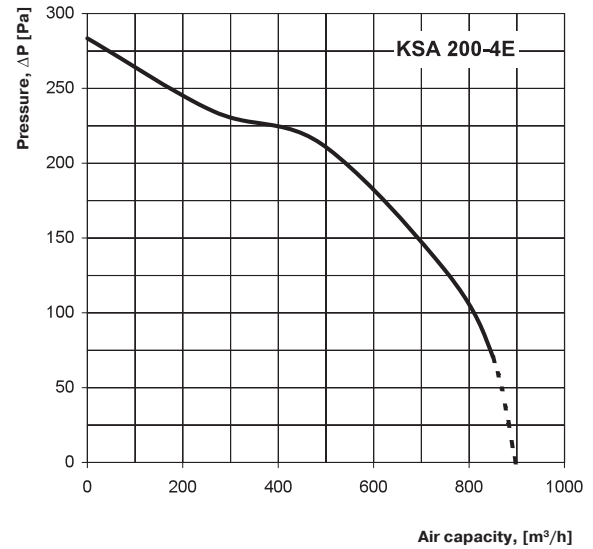

Sound-power level	Hz	Octave-frequency band [Hz]								
		Gen	63	125	250	500	1000	2000	4000	8000
$L_{WA}$ to inlet	dBA	43	39	38	38	31	29	20	17	14
$L_{WA}$ to outlet	dBA	43	36	38	34	34	27	23	18	18
$L_{WA}$ to environment	dBA	38	33	35	31	27	22	16	13	11

**VENTS KSA**

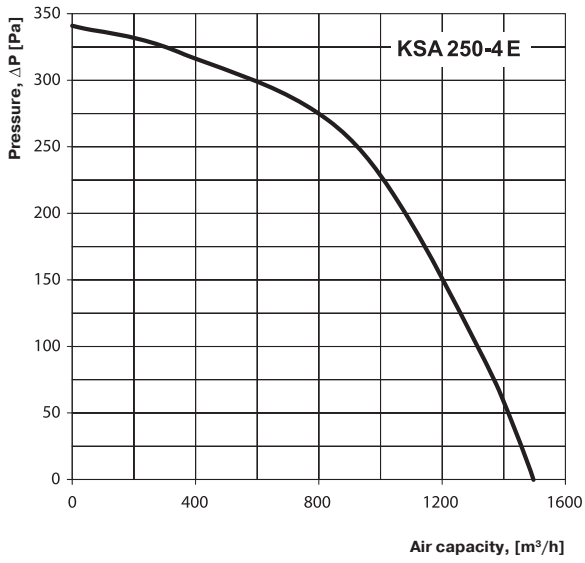

Sound-power level	Hz	Octave-frequency band [Hz]								
		Gen	63	125	250	500	1000	2000	4000	8000
$L_{WA}$ to inlet	dBA	44	41	43	40	32	24	27	24	21
$L_{WA}$ to outlet	dBA	46	41	45	38	32	26	29	22	18
$L_{WA}$ to environment	dBA	41	35	38	33	27	21	24	18	15

**VENTS KSA**

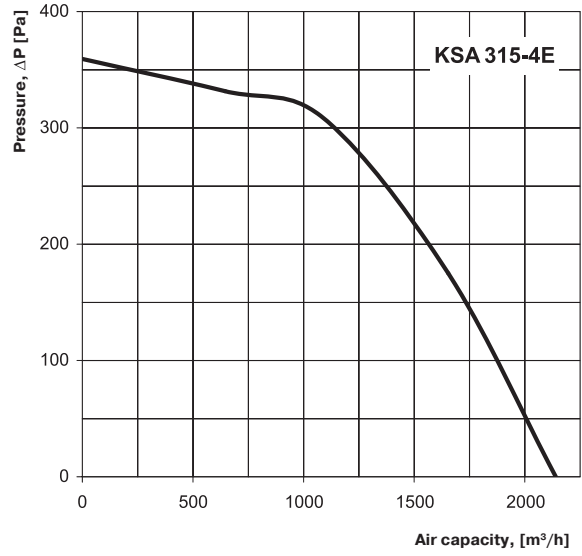

Sound-power level	Hz	Octave-frequency band [Hz]								
		Gen	63	125	250	500	1000	2000	4000	8000
$L_{WA}$ to inlet	dBA	45	41	42	39	29	25	25	27	25
$L_{WA}$ to outlet	dBA	48	43	46	40	35	26	30	20	19
$L_{WA}$ to environment	dBA	44	36	39	31	25	22	25	18	17

FAN SERIES VENTS KSA

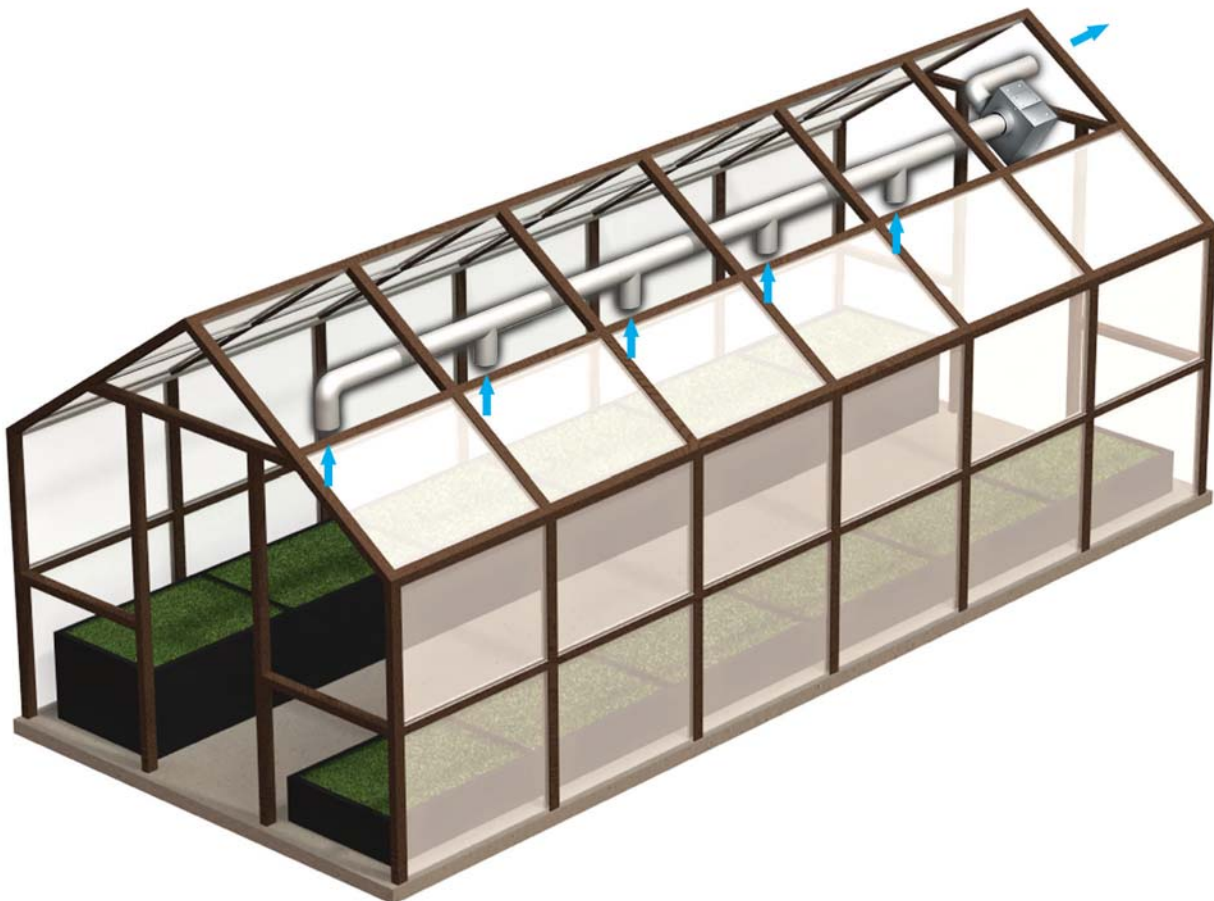

**KSA fan greenhouse ventilation example**

Series  
**VENTS KSB**



In-line centrifugal fans in heat- and sound-insulated casing with the air capacity up to **2150 m<sup>3</sup>/h**

■ **Applications**

KSB fan design enables its application in supply and exhaust ventilation systems for the premises with high requirements to noise level and limited mounting space. Provision is made for installation in a premise above the suspended ceiling. Suitable for connection with 100, 125, 150, 160, 200 and 250 mm round ducts.

■ **Design**

The fan casing is made of galvanized steel sheet and provided with heat- and sound-insulating material. Round connecting pipes are fitted with rubber seals.

■ **Motor**

The centrifugal impeller with back-curved blades is powered by means of 2-pole asynchronous motor with external rotor. The motors are equipped with built-in thermal overheating protection with automatic restart. Motor ball bearings with selective lubricating oil ensure low-noise and maintenance-free fan operation. KSB...M model motor is installed onto the rubber anti-vibration mounts to reduce vibration and noise. Models marked KSB...S are featured with the high-powered motors.

■ **Speed control**

Both smooth or step speed control is performed with the thyristor or autotransformer controller. The motor speed is controlled by means of power voltage decrease. Air capacity as a function of motor speed accordingly. Several fans can be connected to one controller in case their total power and operating current do not exceed the controller rated values.

■ **Mounting**

In-line fans designed for mounting inside the round ducts. The fan shall be fixed to a building by means of supports, suspension brackets or fixation brackets in case of flexible connectors application. The fan can be mounted in any position with respect to the air flow direction indicated with a pointer on the fan casing. Access to the fan maintenance shall be provided.

Designation key: \_\_\_\_\_

Fan series	Connecting pipe diameter	Options
<b>VENTS KSB</b>	100; 125; 150; 160; 200; 250; 315	<b>R</b> – equipped with the power cord and plug; <b>C</b> – equipped with high-power motor; <b>M</b> – Motor on rubber anti-vibration mounts; <b>U</b> – speed controller module with the built in temperature sensor; <b>Un</b> – speed controller module with the external temperature sensor; <b>U1</b> – speed controller with the built in timer and temperature sensor; <b>U1n</b> – speed controller with the built in timer and external temperature sensor.

Accessories



page 240    page 248    page 250    page 254    page 262    page 294    page 296    page 310    page 310    page 311    page 314    page 315



**■ KSB fan with electronic temperature and speed module**

KSB fan with electronic speed control module with temperature sensor is the perfect solution for greenhouse and other premises requiring air temperature control. Fans marked KSB...U fitted with TSC electronic speed control module with temperature sensor provide automatic speed regulation as a function of air temperature in the duct. Temperature and minimum speed can be adjusted with two control knobs on the controller panel. The fan can be supplied either with built-in temperature sensor or external one with 4 m cable and a cover for mechanical damage protection. The LED indicator for thermostat operation is placed at the front panel of the fan.

**■ KSB operation pattern with electronic speed module with temperature sensor**

The set points for the maximum air temperature and the fan speed are manually adjusted by control knobs. Normally the fan operates with the speed which is set by the knob. If the temperature exceeds the set point, the fan boosts to the maximum speed. After that when the temperature drops down below the set point, the fan goes back to preset speed. The switching delay disables frequent motor switching (if the set temperature in the duct is equal to the threshold temperature).

There are two patterns of delay that may be used in various cases:

Temperature sensor delay (KSB...U): if the temperature rises by 2°C above the set temperature,

the motor switches to the increased rotation speed. The motor switches to the preset (low) speed as the temperature drops below the set temperature threshold. This pattern can be used to keep air temperature to within 2°C. In this case fan switches are rare.

2. Timer delay (KSB...U1): the motor sets to higher speed 5 min after the temperature exceeds the set threshold. The motor switches to the preset (low) speed 5 min. after the temperature drops below the set threshold.

This pattern can be used to keep the air temperature at a precise level. In this case the fan switches more frequently than in the pattern of temperature sensor delay, but the intervals do not exceed 5 minutes.

**■ Example for temperature sensor delay:**

Initial conditions:

- rated speed is set as 60% of the maximum speed
- operating threshold is set as 25°C
- air temperature in the duct is 20°C

Fan operates with the rated speed =60%

- air temperature in the duct rises  
fan operates with the rated speed =60%

- air temperature in the duct reaches 27°C  
Fan switches to the speed =100%

- air temperature in the duct goes down  
fan operates with the speed =100%

- temperature in the duct reaches 25°C again  
fan switches to the preset rated speed =60%

motor operates with the motor speed =60%

- the temperature in the duct rises, reaches 25°C and keeps rising

fan switches to the maximum speed =100% and the delay timer switches for 5 minutes on

- the temperature in the duct goes down  
the fan operates with the maximum speed =100%

- the temperature in the duct reaches 25°C and keeps going down

after the timer stops, the motor switches to the preset rated speed (=60%). After the speed switch the timer switches again for 5 minutes on.

- the temperature in the duct rises, reaches 25°C and keeps rising

after the timer stops, the motor switches to the maximum speed (=100%). After the speed switch the timer switches again for 5 minutes on.

Thus, in timer delay pattern the delay timer activates every time the fan speed changes.

**■ Example for timer delay:**

Initial conditions:

- set rotation speed = 60% of maximum speed
- set operating threshold =25°C
- air temperature in the duct =20°C

**Fan overall dimensions:**

Type	Dimensions [mm]							Mass [kg]
	∅D	B	B1	H	L	L1	L2	
KSB 100	99	322	280	192	447	380	350	5,4
KSB 125	124	322	280	192	447	380	350	5,4
KSB 150	149	352	310	212	477	410	380	6,4
KSB 160	159	352	310	212	477	410	380	6,4
KSB 200	199	432	368	287	588	506	480	10,0
KSB 200 S	199	432	368	287	588	506	480	12,0
KSB 250	249	432	368	287	588	506	480	12,5
KSB 315	314	502	438	397	648	566	540	15,5

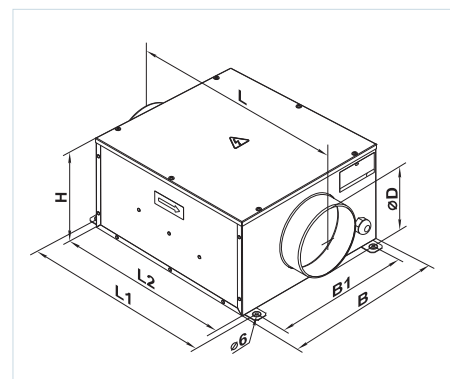

## Technical data:

	KSB 100	KSB 125	KSB 150	KSB 160
Voltage [V / 50 Hz]	230	230	230	230
Power [W]	73	73	72	75
Current [A]	0,32	0,32	0,32	0,33
Maximum air flow [m <sup>3</sup> /h]	240	330	420	420
RPM [min <sup>-1</sup> ]	2560	2590	2600	2690
Noise level at 3 m [dBA]	33	35	36	36
Maximum operating temperature [°C]	-25 +55	-25 +55	-25 +55	-25 +55
Protection rating	IP X4	IP X4	IP X4	IP X4

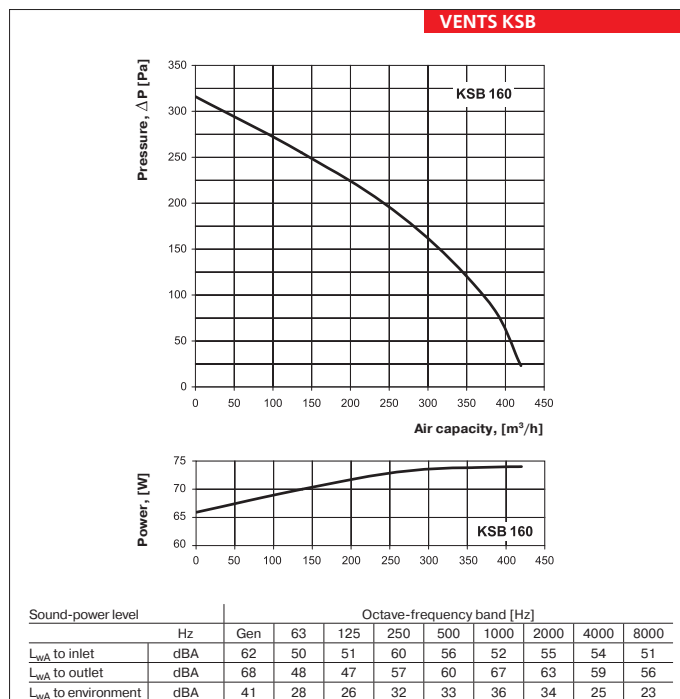
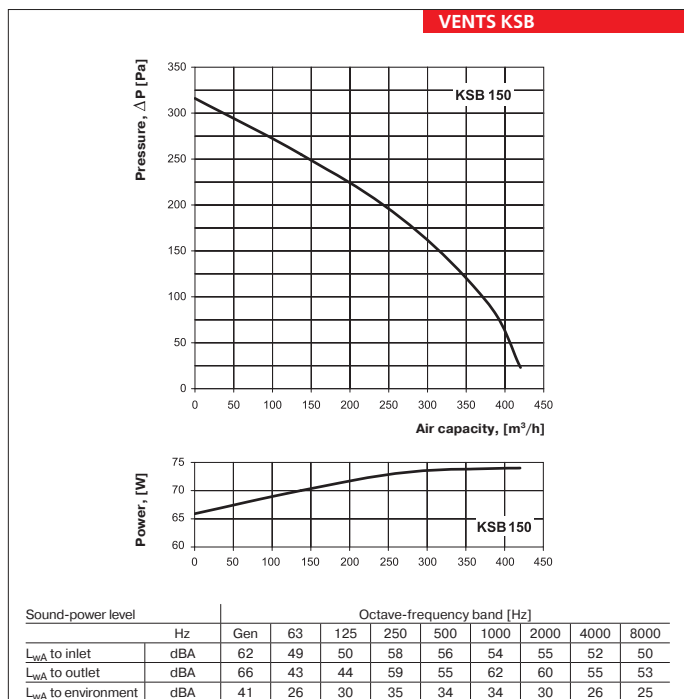
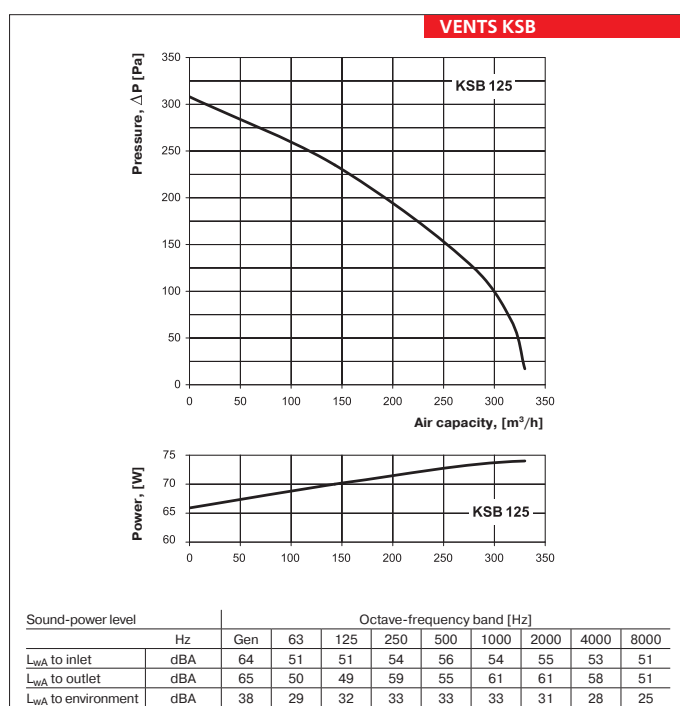
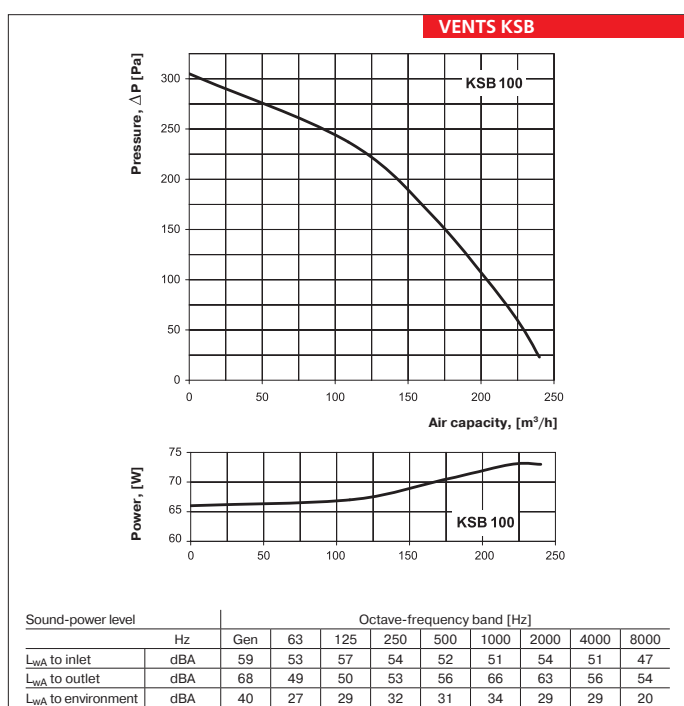





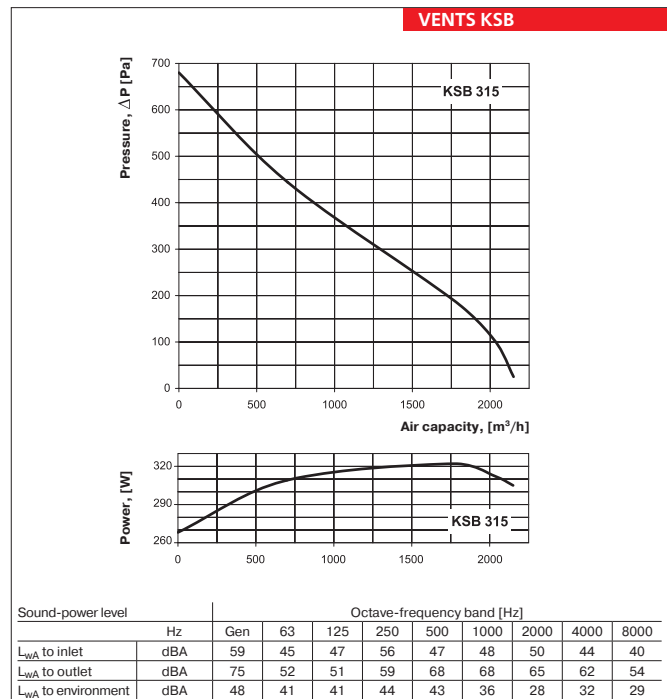
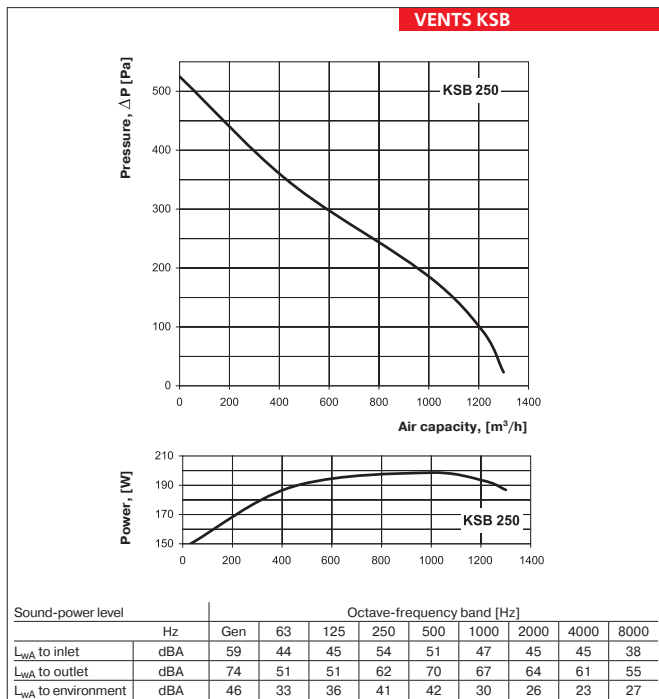
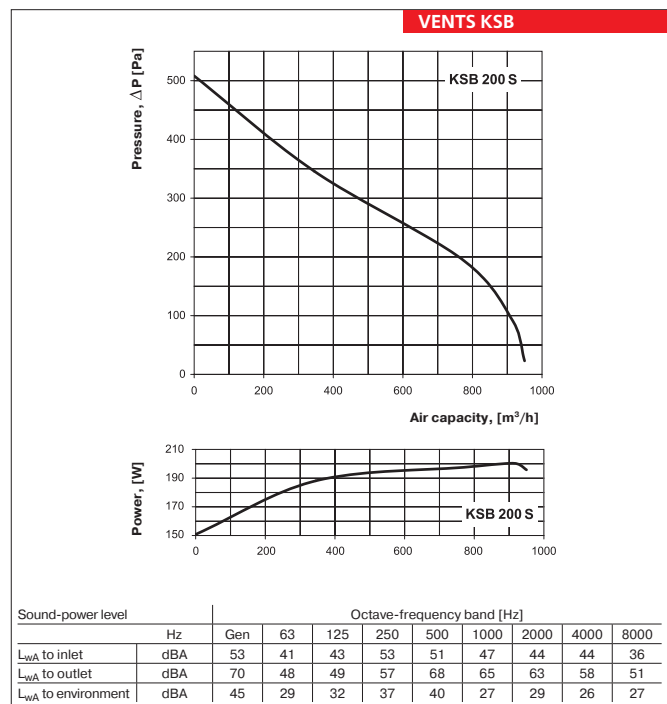
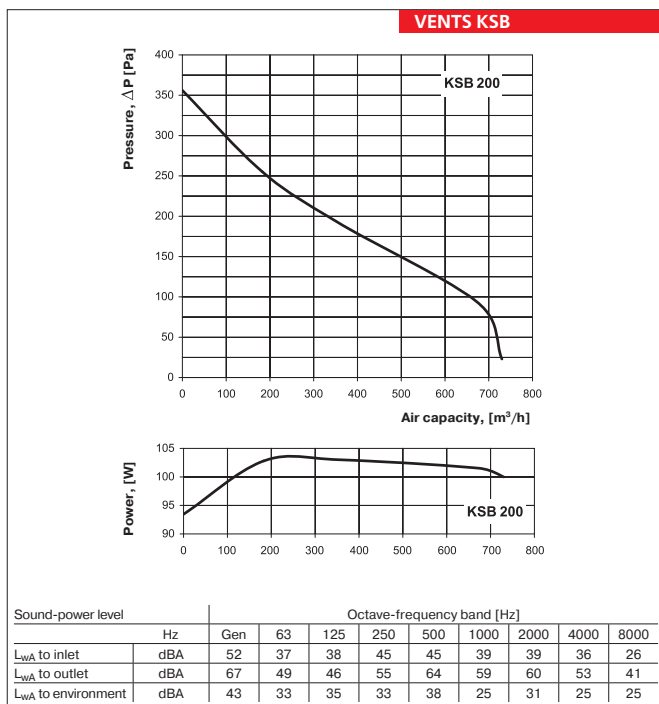















**Technical data:**

	KSB 200	KSB 200 S	KSB 250	KSB 315
Voltage [V / 50 Hz]	230	230	230	230
Power [W]	103	195	198	322
Current [A]	0,45	0,85	0,87	1,40
Maximum air flow [m <sup>3</sup> /h]	730	950	1300	2150
RPM [min <sup>-1</sup> ]	2550	2570	2420	2670
Noise level at 3 m [dBA]	38	41	41	43
Maximum operating temperature [°C]	-25 +50	-25 +45	-25 +50	-25 +45
Protection rating	IP X4	IP X4	IP X4	IP X4



FAN SERIES VENTS KSB

# ELECTRICAL ACCESSORIES COMPATIBILITY

																															
		VS-355-4E	VS-355-4D	VS-400-4E	VS-400-4D	VS-450-4E	VS-450-4D	VS-500-4E	VS-500-4D	VS-560-4D	VS-560-6D	VS-630-4D	VS-630C-4D	VS-630-6D	VS-710-6D	KSA 100-2E	KSA 125-2E	KSA 150-2E	KSA 160-2E	KSA 200-4E	KSA 250-4E	KSB 100	KSB 125	KSB 150	KSB 160	KSB 200	KSB 200 S	KSB 250	KSB 315		
<b>Thyristor speed controllers</b>																															
	RS-1-300	•														•	•	•	•	•		•	•	•	•	•	•	•	•	•	
	RS-1-400	•														•	•	•	•	•		•	•	•	•	•	•	•	•		
	RS-1 N (V)															•	•			•		•	•	•	•	•	•	•	•		
	RS-1,5 N (V)	•														•	•	•	•	•		•	•	•	•	•	•	•	•		
	RS-2 N (V)	•														•	•	•	•	•		•	•	•	•	•	•	•	•		
	RS-2,5 N (V)	•	•													•	•	•	•	•		•	•	•	•	•	•	•	•		
	RS-0,5-PS																			•		•	•	•	•	•	•	•	•		
	RS-1,5-PS	•														•	•	•	•	•		•	•	•	•	•	•	•	•		
	RS-2,5-PS	•	•													•	•	•	•	•		•	•	•	•	•	•	•	•		
	RS-4,0-PS	•	•			•										•	•	•	•	•		•	•	•	•	•	•	•	•		
	RS-1,5-T	•														•	•	•	•	•		•	•	•	•	•	•	•	•		
	RS-3,0-T	•	•													•	•	•	•	•		•	•	•	•	•	•	•	•		
	RS-5,0-T	•	•			•										•	•	•	•	•		•	•	•	•	•	•	•	•		
	RS-10,0-T	•	•			•		•								•	•	•	•	•		•	•	•	•	•	•	•	•		
	RS-1,5-TA	•														•	•	•	•	•		•	•	•	•	•	•	•	•		
	RS-3,0-TA	•	•													•	•	•	•	•		•	•	•	•	•	•	•	•		
	RS-5,0-TA	•	•			•										•	•	•	•	•		•	•	•	•	•	•	•	•		
	RS-10,0-TA	•	•			•		•								•	•	•	•	•		•	•	•	•	•	•	•	•		
<b>Transformer speed controllers</b>																															
	RSA5E-2-P	•														•	•	•	•	•		•	•	•	•	•	•	•	•		
	RSA5E-2-M	•														•	•	•	•	•		•	•	•	•	•	•	•	•		
	RSA5E-3-M	•	•													•	•	•	•	•		•	•	•	•	•	•	•	•		
	RSA5E-4-M	•	•			•										•	•	•	•	•		•	•	•	•	•	•	•	•		
	RSA5E-12-M	•	•			•		•								•	•	•	•	•		•	•	•	•	•	•	•	•		
	RSA5E-1,5-T	•														•	•	•	•	•		•	•	•	•	•	•	•	•		
	RSA5E-3,5-T	•	•			•										•	•	•	•	•		•	•	•	•	•	•	•	•		
	RSA5E-5,0-T	•	•			•										•	•	•	•	•		•	•	•	•	•	•	•	•		
	RSA5E-8,0-T	•	•			•		•								•	•	•	•	•		•	•	•	•	•	•	•	•		
	RSA5E-10,0-T	•	•			•		•								•	•	•	•	•		•	•	•	•	•	•	•	•		
	RSA5D-1,5-T		•		•	•																									
	RSA5D-3,5-T	•	•	•	•																										
	RSA5D-5-M	•	•	•	•	•		•																							
	RSA5D-8-M	•	•	•	•	•		•	•	•	•	•	•	•	•																
	RSA5D-10-M	•	•	•	•	•		•	•	•	•	•	•	•	•																
	RSA5D-12-M	•	•	•	•	•		•	•	•	•	•	•	•	•																
<b>Frequency speed controllers</b>																															
	VFED-200-TA	•			•																										
	VFED-400-TA	•			•	•		•																							
	VFED-750-TA	•			•	•		•																							
	VFED-1100-TA	•			•	•		•	•	•	•	•	•	•	•																
	VFED-1500-TA	•			•	•		•	•	•	•	•	•	•	•																
<b>Temperature regulators</b>																															
	RTS-1-400																														
	RTSD-1-400																														
	RT-10	•														•	•	•	•	•		•	•	•	•	•	•	•	•		
<b>Multi-speed fan switches</b>																															
	P2-5,0																														
	P3-5,0																														
	P5-5,0																														
	P2-1-300																														
	P3-1-300																														
<b>EC-motors controllers</b>																															
	R-1/010																														
<b>Sensors</b>																															
	T-1,5 N	•														•	•	•	•	•		•	•	•	•	•	•	•	•		
	TH-1,5 N	•														•	•	•	•	•		•	•	•	•	•	•	•	•		
	TF-1,5 N	•														•	•	•	•	•		•	•	•	•	•	•	•	•		
	TP-1,5 N	•														•	•	•	•	•		•	•	•	•	•	•	•	•		

• recommended

• suitable





# CENTRIFUGAL FANS

## ▶ VENTS VCU Series



- ▶ Single-inlet scroll-type centrifugal fans with external rotor motor and the air capacity up to 2000 m<sup>3</sup>/h. The fan is designed for the supply and exhaust ventilation systems.

## ▶ VENTS VCUN Series

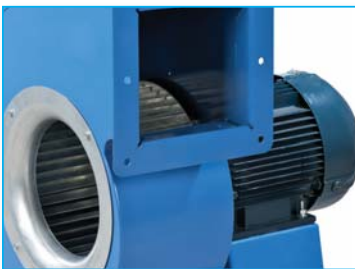

- ▶ Single-inlet scroll-type centrifugal fans with the impeller mounted on the three-phase asynchronous motor shaft. The air capacity is up to 19 000 m<sup>3</sup>/h. The fan is designed for supply and exhaust ventilation systems.



**VENTS VCU**  
centrifugal fan in scroll casing  
Air capacity – up to 2000 m<sup>3</sup>/h

page  
112

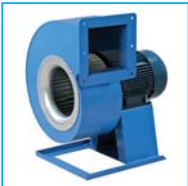

**VENTS VCUN**  
centrifugal fan in scroll casing  
Air capacity – up to 19 000 m<sup>3</sup>/h

page  
116

Series  
**VENTS VCU**



Scroll-type single-inlet centrifugal fans powered by the motors with external rotor. The air capacity up to **2000 m<sup>3</sup>/h**. The fan is designed for supply and exhaust ventilation systems.

■ **Applications**

Designed for supply and exhaust ventilation of various premises. The fan can be used as a components for ventilation and air conditioning systems and is suitable for outside mounting.

■ **Design**

The fan casing is made of steel with polymeric coating.

■ **Motor**

The impeller with forward-curved blades of galvanized steel is powered by 2- and 4-pole asynchronous motor with external rotor. The motors are equipped with incorporated thermal overheating protection with automatic restart as well as ball bearings for long service life. For precise features, safe operation and low noise, each turbine is dynamically balanced while assembling. Motor protection rating IP 44.

■ **Speed control**

Both smooth and step speed control is performed with the symistor or autotransformer controller. Several fans can be connected to one controller in case the total power and operating current do not exceed the controller rated values.

■ **Mounting**

The fan is suitable for installation in ventilating chambers, air conditioning units or can be used separately. In case of independent operation it can be connected to air ducts by means of either both exhaust and inlet branch pipes or exhaust branch pipe only. The exhaust and intake branch pipes have rectangular or circular sections accordingly. Power is supplied by means of the external terminals.

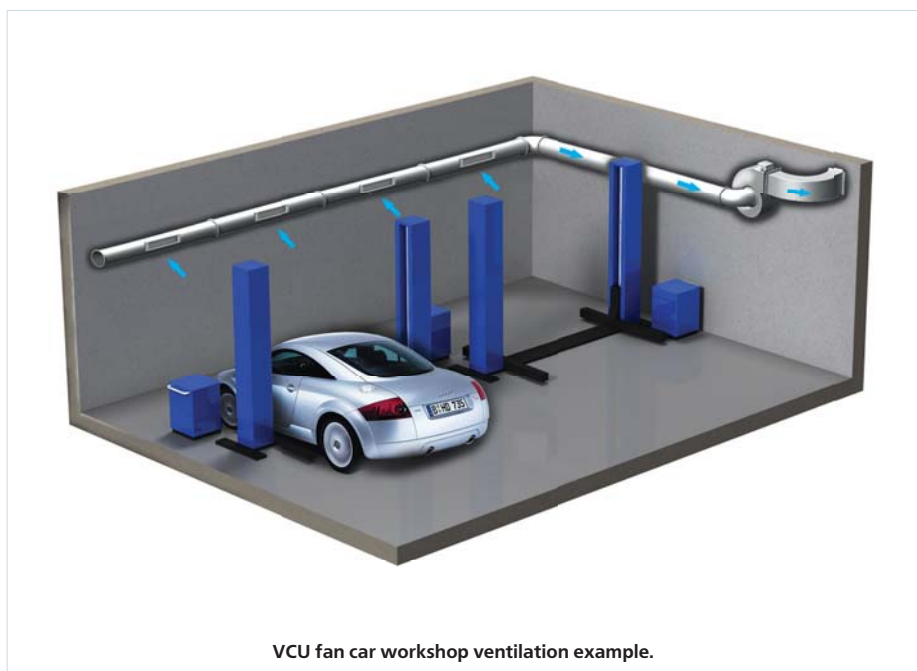

VCU fan car workshop ventilation example.

**Designation key:** \_\_\_\_\_

Series	Motor modification		Impeller diameter, mm	Impeller width, mm
<b>VENTS VCU</b>	Number of poles	Phase	140; 160; 180; 200; 225; 250	60; 62; 80; 90; 92; 102; 140
	2 4	<b>E</b> – single phase		

**Accessories**



page 240    page 248    page 250    page 254    page 262    page 294    page 296    page 310    page 310    page 311    page 314    page 315

**Technical data:**

	VCU 2E 140x60	VCU 2E 160x62	VCU 2E 160x90	VCU 4E 180x92
Voltage [V / 50 Hz]	230	230	230	230
Power [W]	148	240	320	160
Current [A]	0,64	1,05	1,48	0,7
Maximum air flow [m <sup>3</sup> /h]	515	600	730	800
RPM [min <sup>-1</sup> ]	2820	2100	2745	1465
Noise level at 3 m [dBA]	68	68	70	62
Maximum operating temperature [°C]	-25 +45	-25 +50	-25 +45	-25 +45
Protection rating	IP X4	IP X4	IP X4	IP X4

**Technical data:**

	VCU 4E 200x80	VCU 4E 200x102	VCU 4E 225x102	VCU 4E 250x140
Voltage [V / 50 Hz]	230	230	230	230
Power [W]	125	280	395	570
Current [A]	0,55	1,25	1,98	2,48
Maximum air flow [m <sup>3</sup> /h]	730	1350	1480	2000
RPM [min <sup>-1</sup> ]	1430	1475	1330	1310
Noise level at 3 m [dBA]	63	65	69	60
Maximum operating temperature [°C]	-25 +45	-25 +40	-40 +70	-40 +70
Protection rating	IP X4	IP X4	IP X4	IP X4

**Fan overall dimensions:**

Type	Dimensions [mm]								Mass [kg]
	∅D	B	H	H1	H2	L	L1	L2	
VCU 2E 140x60	140	243	287	125	93	85	107	75	3,2
VCU 2E 160x62	160	277	324	136	106	89	112	82	4,2
VCU 2E 160x90	160	277	324	136	106	136	158	127	5,1
VCU 4E 180x92	180	311	360	150	120	145	166	137	6,5
VCU 4E 200x80	200	335	398	165	134	121	140	113	6,8
VCU 4E 200x102	200	335	398	165	134	157	175	148	7,3

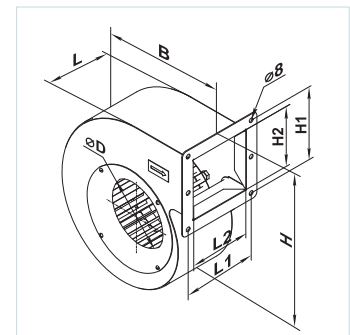
**Fan overall dimensions:**

Type	Dimensions [mm]										Mass [kg]
	∅D	B	H	H1	H2	L	L1	L2	P	M	
VCU 4E 225x102	225	365	441	210	171	145	170	137	178	250	11,2
VCU 4E 250x140	250	410	485	230	191	205	230	197	238	270	15,5

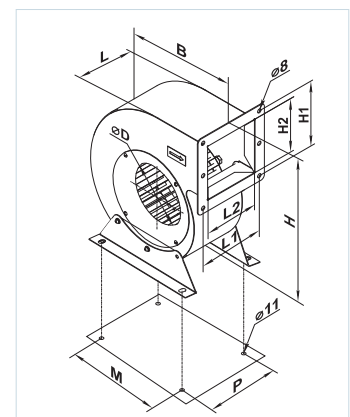

VENTS VCU

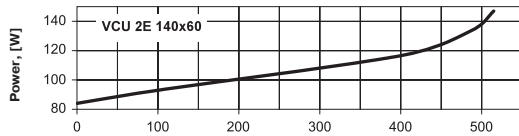
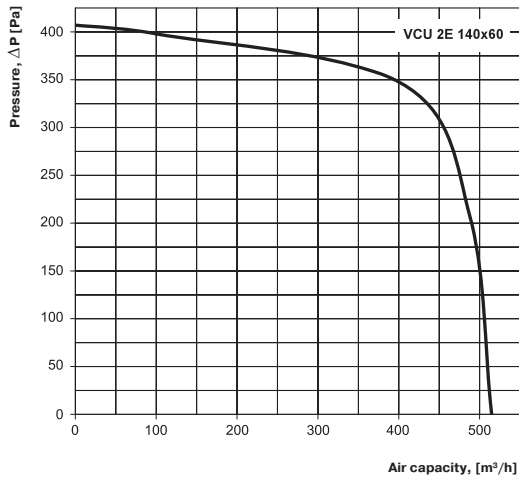

Sound-power level	Hz	Octave-frequency band [Hz]								
		Gen	63	125	250	500	1000	2000	4000	8000
$L_{WA}$ to inlet	dBA	60	44	51	50	37	33	31	27	17
$L_{WA}$ to outlet	dBA	58	45	53	44	43	38	31	26	19
$L_{WA}$ to environment	dBA	50	41	48	44	35	31	24	20	15

VENTS VCU

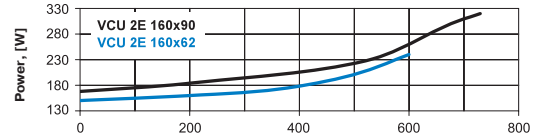
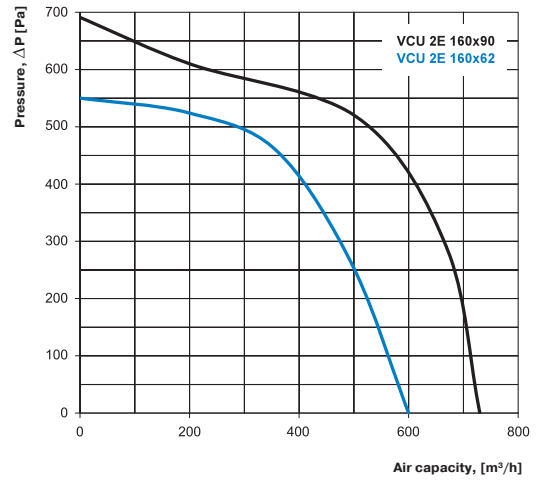

VCU 2E 160x90

Sound-power level	Hz	Octave-frequency band [Hz]								
		Gen	63	125	250	500	1000	2000	4000	8000
$L_{WA}$ to inlet	dBA	58	41	55	53	40	33	33	25	21
$L_{WA}$ to outlet	dBA	57	45	56	46	43	36	30	26	21
$L_{WA}$ to environment	dBA	51	39	48	45	36	32	25	20	17

VCU 2E 160x62

Sound-power level	Hz	Octave-frequency band [Hz]								
		Gen	63	125	250	500	1000	2000	4000	8000
$L_{WA}$ to inlet	dBA	57	42	54	54	38	34	31	28	21
$L_{WA}$ to outlet	dBA	57	46	57	45	42	38	31	26	20
$L_{WA}$ to environment	dBA	49	37	48	42	33	29	25	19	16

VENTS VCU

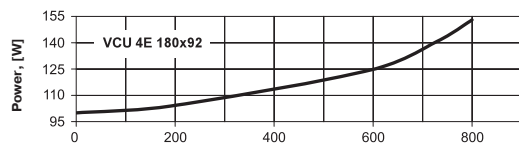
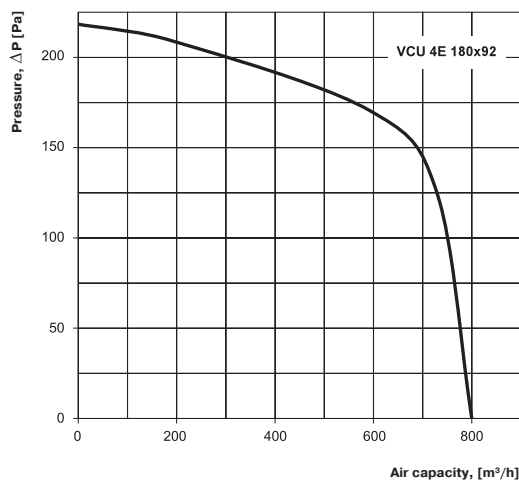

Sound-power level	Hz	Octave-frequency band [Hz]								
		Gen	63	125	250	500	1000	2000	4000	8000
$L_{WA}$ to inlet	dBA	56	43	54	52	38	34	30	29	17
$L_{WA}$ to outlet	dBA	56	46	55	45	42	35	30	27	21
$L_{WA}$ to environment	dBA	52	39	47	46	35	28	24	18	17



**VENTS VCU**

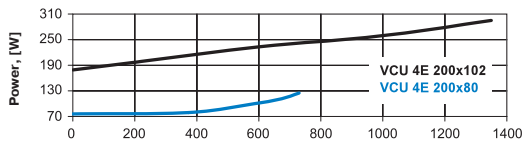
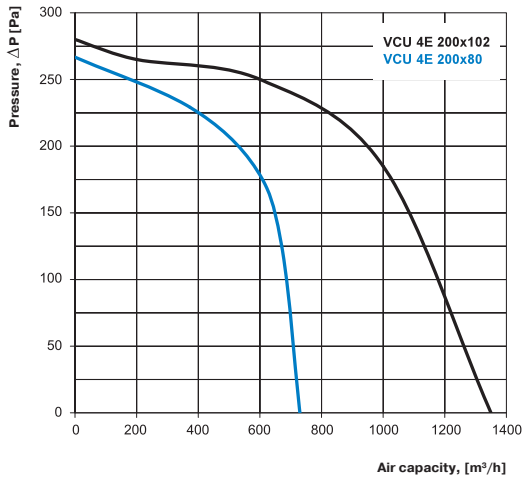

**VCU 4E 200x102**

Sound-power level		Octave-frequency band [Hz]									
		Hz	Gen	63	125	250	500	1000	2000	4000	8000
$L_{WA}$ to inlet	dBA	41	37	38	37	30	26	19	17	14	
$L_{WA}$ to outlet	dBA	42	40	41	36	36	25	16	17	18	
$L_{WA}$ to environment	dBA	37	32	35	29	26	20	16	11	11	

**VCU 4E 200x80**

Sound-power level		Octave-frequency band [Hz]									
		Hz	Gen	63	125	250	500	1000	2000	4000	8000
$L_{WA}$ to inlet	dBA	41	38	39	34	31	29	20	18	13	
$L_{WA}$ to outlet	dBA	44	40	40	36	34	25	20	16	17	
$L_{WA}$ to environment	dBA	37	33	37	30	25	21	16	13	13	

**VENTS VCU**

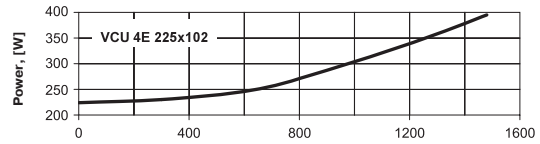
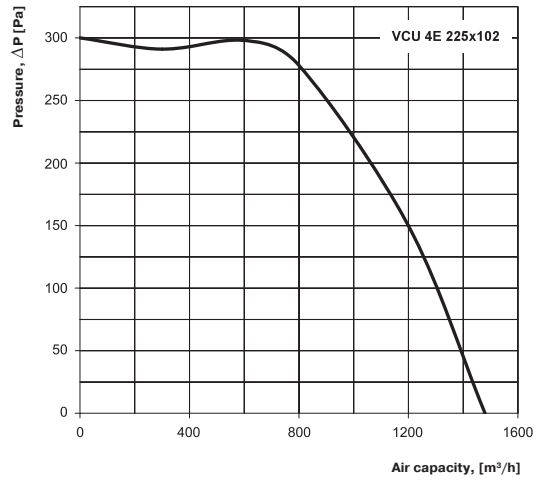

Sound-power level

Sound-power level		Octave-frequency band [Hz]									
		Hz	Gen	63	125	250	500	1000	2000	4000	8000
$L_{WA}$ to inlet	dBA	39	37	38	38	31	28	21	17	15	
$L_{WA}$ to outlet	dBA	44	37	41	38	34	27	16	17	19	
$L_{WA}$ to environment	dBA	37	31	33	31	25	20	17	13	11	

**VENTS VCU**

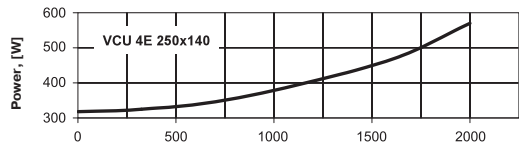
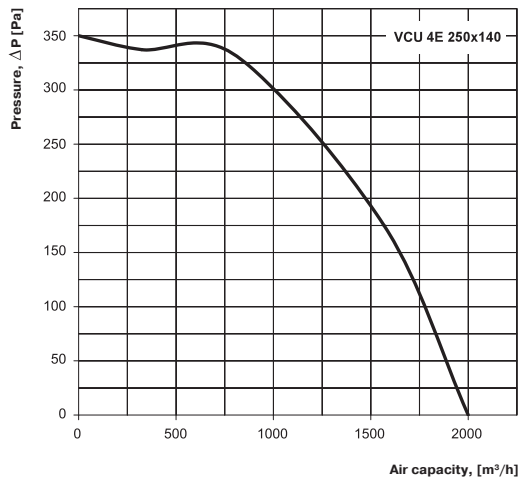

Sound-power level

Sound-power level		Octave-frequency band [Hz]									
		Hz	Gen	63	125	250	500	1000	2000	4000	8000
$L_{WA}$ to inlet	dBA	44	44	42	36	31	22	29	21	19	
$L_{WA}$ to outlet	dBA	46	37	42	38	29	28	29	23	21	
$L_{WA}$ to environment	dBA	40	34	37	31	27	21	24	17	14	

Series  
**VENTS VCUN**



Scroll single-inlet centrifugal fans with the impeller mounted directly on the three-phase asynchronous motor shaft. Air capacity up to **19 000 m<sup>3</sup>/h**. The fan is designed for supply and exhaust ventilation systems.

■ **Applications**

Supply and exhaust ventilation systems for various premises. The fans can be used as components for ventilation and air conditioning units and are suitable for outdoor mounting.

■ **Design**

The fan casing is made of steel with polymeric coating. VCUN fan can be supplied both with the clockwise or counterclockwise rotation impeller. Each modification has few scroll positions to enable connection to the air ducts at any angle with 45° pitch distance.

■ **Motor**

The impeller with galvanized forward-curved blades is mounted directly on the 2-, 4-, 6- or 8-pole three-phase asynchronous motor shaft. Ball bearings in the motor ensure long service life. For precise features, safe operation and low noise, each turbine is dynamically balanced while assembly. Motor protection rating IP 54.

■ **Speed control**

Both smooth or step speed control is performed by means of the autotransformer or frequency controller. Several fans can be connected to one controller in case the total power and operating current do not exceed the rated controller values.

■ **Mounting**

The fan is suitable for installation in ventilating chambers, air conditioning units or can be used separately. In case of independent operation it can be connected to air ducts by means of both exhaust and intake branch pipes or exhaust branch pipe only. The exhaust and inlet branch pipes have rectangular or circular sections accordingly. Power is supplied by means of external terminals.



**Designation key:**

Series	Impeller diameter, mm	Impeller width, mm	Motor modification		Scroll orientation*	Casing rotation angle*
			Power [kW]	Number of poles		
<b>VENTS VCUN</b>	140; 160; 180; 200; 225; 250; 280; 315; 355; 400; 450; 500	74; 93; 103; 127; 143; 183; 203; 229	0,25; 0,37; 0,55; 0,75; 1,1; 1,5; 2,2; 3; 4; 5,5; 7,5; 11	2; 4; 6; 8	R – right side; L – left side	0; 45; 90; 135; 180; 225; 270; 315

\* Standard casing modification PR90 (refer picture).

**Accessories**



page 240    page 240    page 248    page 250    page 254    page 262    page 294    page 296    page 301    page 313    page 318    page 319

**Technical data:**

	VCUN 140x74- 0,25-4	VCUN 140x74- 0,37-2	VCUN 160x74- 0,55-4	VCUN 160x74- 0,75-2	VCUN 180x74- 0,55-4	VCUN 180x74- 1,1-2	VCUN 200x93- 0,55-4	VCUN 200x93- 1,1-2
Voltage [V / 50 Hz]	400	400	400	400	400	400	400	400
Power [kW]	0,25	0,37	0,55	0,75	0,55	1,1	0,55	1,1
Current [A]	0,8	0,9	1,6	1,8	1,6	2,6	1,6	2,6
Maximum air flow [m <sup>3</sup> /h]	450	710	750	1540	1030	1950	1615	1900
RPM [min <sup>-1</sup> ]	1350	2730	1360	2820	1360	2800	1360	2800
Noise level at 3 m [dBA]	60	65	62	68	64	70	67	73
Maximum operating temperature [°C]	60	60	60	60	60	60	60	60
Protection rating	IP 54	IP 54	IP 54	IP 54	IP 54	IP 54	IP 54	IP 54

**Technical data:**

	VCUN 225x103- 1,1-4	VCUN 225x103- 2,2-2	VCUN 240x114- 2,2-4	VCUN 240x114- 3,0-2	VCUN 250x127- 1,5-6	VCUN 250x127- 2,2-4	VCUN 250x127- 5,5-2	VCUN 280x127- 1,5-6
Voltage [V / 50 Hz]	400	400	400	400	400	400	400	400
Power [kW]	1,1	2,2	2,2	3,0	1,5	2,2	5,5	1,5
Current [A]	2,8	4,7	5,1	6,1	4,2	5,1	10,7	4,2
Maximum air flow [m <sup>3</sup> /h]	2125	3350	2930	4350	2415	3720	4820	3450
RPM [min <sup>-1</sup> ]	1420	2865	1420	2870	940	1420	2850	940
Noise level at 3 m [dBA]	72	75	74	78	68	78	81	69
Maximum operating temperature [°C]	60	60	60	60	60	60	60	60
Protection rating	IP 54	IP 54	IP 54	IP 54	IP 54	IP 54	IP 54	IP 54

**Technical data:**

	VCUN 280x127- 2,2-4	VCUN 280x127- 5,5-2	VCUN 315x143- 2,2-6	VCUN 315x143- 4,0-4	VCUN 355x143- 2,2-6	VCUN 355x143- 4,0-4	VCUN 400x183- 1,5-8	VCUN 400x183- 2,2-6
Voltage [V / 50 Hz]	400	400	400	400	400	400	400	400
Power [kW]	2,2	5,5	2,2	4,0	2,2	4,0	1,5	2,2
Current [A]	5,1	10,7	5,6	8,7	5,6	8,7	4,2	5,8
Maximum air flow [m <sup>3</sup> /h]	4395	6330	4375	6530	5090	8150	6545	8100
RPM [min <sup>-1</sup> ]	1420	2850	940	1410	940	1410	700	940
Noise level at 3 m [dBA]	75	81	70	79	71	79	62	73
Maximum operating temperature [°C]	60	60	60	60	60	60	60	60
Protection rating	IP 54	IP 54	IP 54	IP 54	IP 54	IP 54	IP 54	IP 54

**Technical data:**

	VCUN 400x183- 5,5-4	VCUN 450x203- 3,0-8	VCUN 450x203- 4,0-6	VCUN 450x203- 11,0-4	VCUN 500x229- 5,5-8	VCUN 500x229- 7,5-6	VCUN 500x229- 11,0-4
Voltage [V / 50 Hz]	400	400	400	400	400	400	400
Power [kW]	5,5	3,0	4,0	11,0	5,5	7,5	11,0
Current [A]	11,0	7,8	9,1	24,0	14,8	17,0	24,0
Maximum air flow [m <sup>3</sup> /h]	10175	10230	11150	19000	11550	14960	17250
RPM [min <sup>-1</sup> ]	1430	700	950	1450	700	955	1450
Noise level at 3 m [dBA]	80	70	76	84	72	78	85
Maximum operating temperature [°C]	60	60	60	60	60	60	60
Protection rating	IP 54	IP 54	IP 54	IP 54	IP 54	IP 54	IP 54

**SELECTION TABLE FOR ACCESSORIES:**

Type	Rubber anti-vibration mounts	Spring-loaded anti-vibration mounts	Flange	Grille								
VCUN 140x74-0,25-4	VVZnr 8	VVZnp 8	FVZn 140	RVZn 140								
VCUN 140x74-0,37-2				RVZn 160								
VCUN 160x74-0,55-4			VVZnr 16	VVZnp 16	FVZn 180	RVZn 180						
VCUN 160x74-0,75-2						RVZn 200						
VCUN 180x74-0,55-4					VVZnr 26	VVZnp 26	FVZn 225	RVZn 225				
VCUN 180x74-1,1-2								RVZn 240				
VCUN 200x93-0,55-4							VVZnr 35	VVZnp 35	FVZn 250	RVZn 250		
VCUN 200x93-1,1-2										RVZn 280		
VCUN 225x103-1,1-4									VVZnr 50	VVZnp 50	FVZn 315	RVZn 315
VCUN 225x103-2,2-2												RVZn 355
VCUN 240x114-2,2-4	VVZnr 75	VVZnp 75	FVZn 400	RVZn 400								
VCUN 240x114-3,0-2				RVZn 450								
VCUN 250x127-1,5-6	VVZnr 75	VVZnp 75	FVZn 450	RVZn 450								
VCUN 250x127-2,2-4				RVZn 500								
VCUN 250x127-5,5-2	VVZnr 75	VVZnp 75	FVZn 500	RVZn 500								
VCUN 280x127-1,5-6				RVZn 500								
VCUN 280x127-2,2-4				RVZn 500								
VCUN 280x127-5,5-2												
VCUN 315x143-2,2-6												
VCUN 315x143-4,0-4												
VCUN 355x143-2,2-6												
VCUN 355x143-4,0-4												
VCUN 400x183-1,5-8												
VCUN 400x183-2,2-6												
VCUN 400x183-5,5-4												
VCUN 450x203-3,0-8												
VCUN 450x203-4,0-6												
VCUN 450x203-11,0-4												
VCUN 500x229-5,5-8												
VCUN 500x229-7,5-6												
VCUN 500x229-11,0-4												

**FVZn Flange**

designed to connect round ducts to VCUN fans.

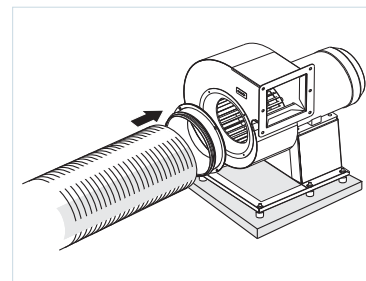

**RVZn Grille**

designed for fan protection against foreign objects.

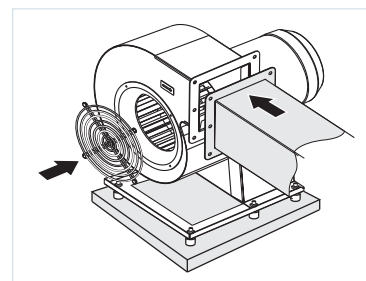

**Anti-vibration mounts VVZnr and VVZnp**

Designed for noise reduction and vibration damping produced by the fans. Provide dynamic loading decrease and increase reliability and durability of ventilation equipment.



Anti-vibration mount VVZnr



Anti-vibration mount VVZnp

**Fan overall dimensions:**

Type	Dimensions [mm]																	Mass [kg]
	∅D	∅d	∅d1	B	H	H1	H2	H3	L	L1	L2	P	M	I	G	K	S	
VCUN 140x74-0,25-4	140	8	10	242	323	125	92	144	309	125	95	124	220	234	18	253	80	9,3
VCUN 140x74-0,37-2	140	8	10	242	323	125	92	144	309	125	95	124	220	234	18	253	80	9,3
VCUN 160x74-0,55-4	160	8	10	277	373	134	106	173	356	134	104	141	220	260	17	252	90	12,7
VCUN 160x74-0,75-2	160	8	10	277	373	134	106	173	356	134	104	141	220	260	17	252	90	13,0
VCUN 180x74-0,55-4	180	10	10	311	414	143	120	193	365	143	114	146	270	270	22	314	90	13,5
VCUN 180x74-1,1-2	180	10	10	311	414	143	120	193	365	143	114	146	270	270	22	314	90	14,5
VCUN 200x93-0,55-4	200	10	10	345	436	160	134	193	380	160	129	158	270	284	24	315	90	15,2
VCUN 200x93-1,1-2	200	10	10	345	436	160	134	193	380	160	129	158	270	284	24	315	90	16,2
VCUN 225x103-1,1-4	225	10	12	388	507	178	151	232	432	172	141	174	275	316	27	330	100	21,2
VCUN 225x103-2,2-2	225	10	12	388	507	178	151	232	432	172	141	174	275	316	27	330	100	24,2
VCUN 240x114-2,2-4	240	10	12	414	568	186	161	282	461	186	156	195	275	362	27	330	125	30,5
VCUN 240x114-3,0-2	240	10	12	414	568	186	161	282	461	186	156	195	275	362	27	330	125	31,4
VCUN 250x127-1,5-6	250	10	12	431	594	202	168	292	473	202	166	206	300	373	27	355	125	33,0
VCUN 250x127-2,2-4	250	10	12	431	594	202	168	292	473	202	166	206	300	373	27	355	125	32,2
VCUN 250x127-5,5-2	250	10	12	431	614	202	168	312	517	202	166	213	300	397	27	355	140	40,0
VCUN 280x127-1,5-6	280	10	12	483	626	225	189	292	503	231	196	243	300	410	27	355	125	35,1
VCUN 280x127-2,2-4	280	10	12	483	626	225	189	292	503	231	196	243	300	410	27	355	125	34,2
VCUN 280x127-5,5-2	280	10	12	483	646	225	189	312	545	231	196	243	300	427	27	355	140	42,4
VCUN 315x143-2,2-6	315	10	15	543	731	250	213	353	568	255	216	268	350	452	27	405	140	46,8
VCUN 315x143-4,0-4	315	10	15	543	731	250	213	353	568	255	216	268	350	452	27	405	140	49,8
VCUN 355x143-2,2-6	355	10	15	611	817	275	241	403	566	255	214	253	350	442	32	405	140	49,0
VCUN 355x143-4,0-4	355	10	15	611	817	275	241	403	566	255	214	253	350	442	32	405	140	51,0
VCUN 400x183-1,5-8	400	10	15	689	870	310	272	403	619	310	268	313	400	497	27	455	140	57,1
VCUN 400x183-2,2-6	400	10	15	689	870	310	272	403	619	310	268	313	400	497	27	455	140	54,1
VCUN 400x183-5,5-4	400	10	15	689	882	310	272	414	662	330	289	341	400	525	27	455	140	69,5
VCUN 450x203-3,0-8	450	10	15	774	985	345	306	464	690	352	315	351	450	550	42	530	140	77,8
VCUN 450x203-4,0-6	450	10	15	774	985	345	306	464	690	352	315	351	450	550	42	530	140	76,5
VCUN 450x203-11,0-4	450	10	15	774	1005	345	306	484	722	352	315	371	450	608	42	530	178	105,0
VCUN 500x229-5,5-8	500	11	15	860	1115	390	341	534	761	401	353	408	500	645	42	580	178	85,0
VCUN 500x229-7,5-6	500	11	15	860	1115	390	341	534	761	401	353	408	500	645	42	580	178	86,0
VCUN 500x229-11,0-4	500	11	15	860	1115	390	341	534	761	401	353	408	500	645	42	580	178	107,0

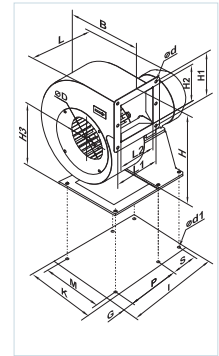

FAN SERIES VENTS VCUN

**Scroll orientation (view on the intake side)**

Right scroll orientation

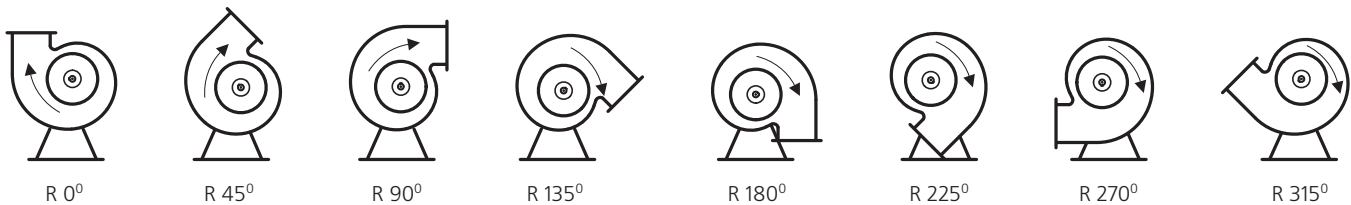

Left scroll orientation

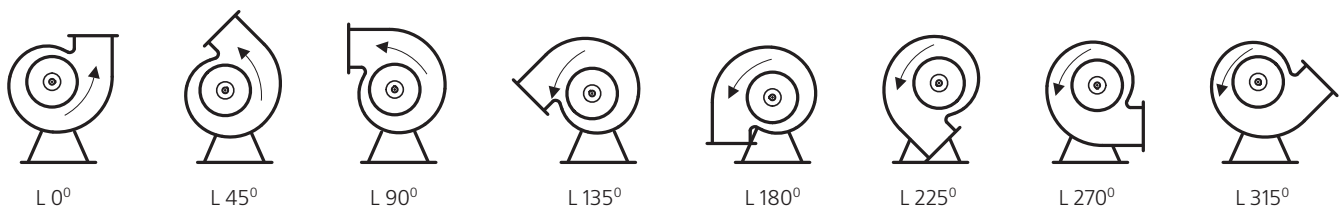



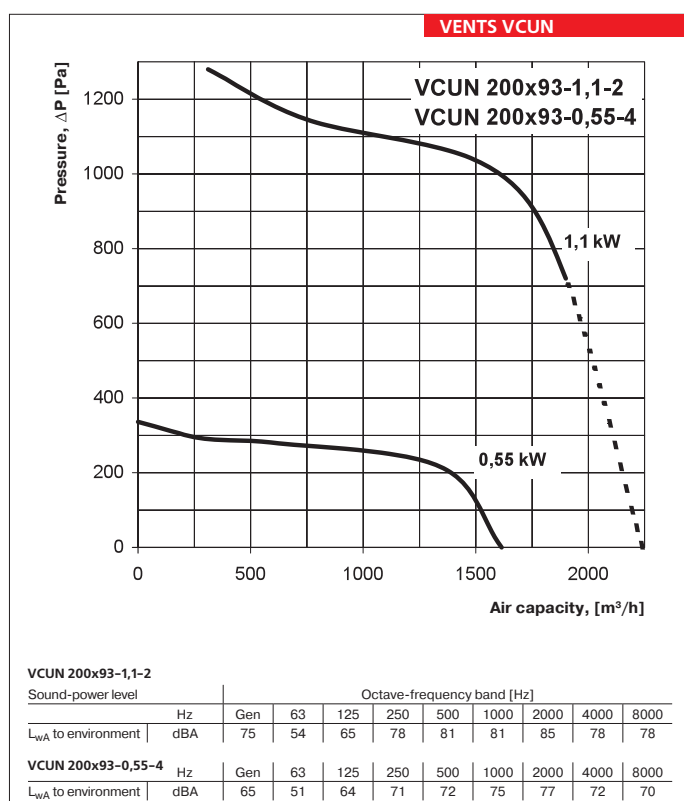
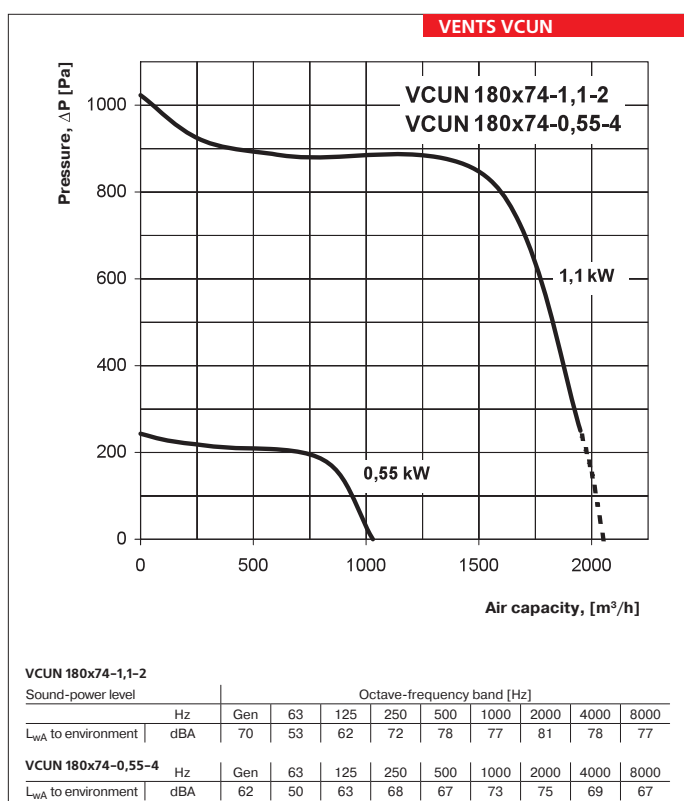
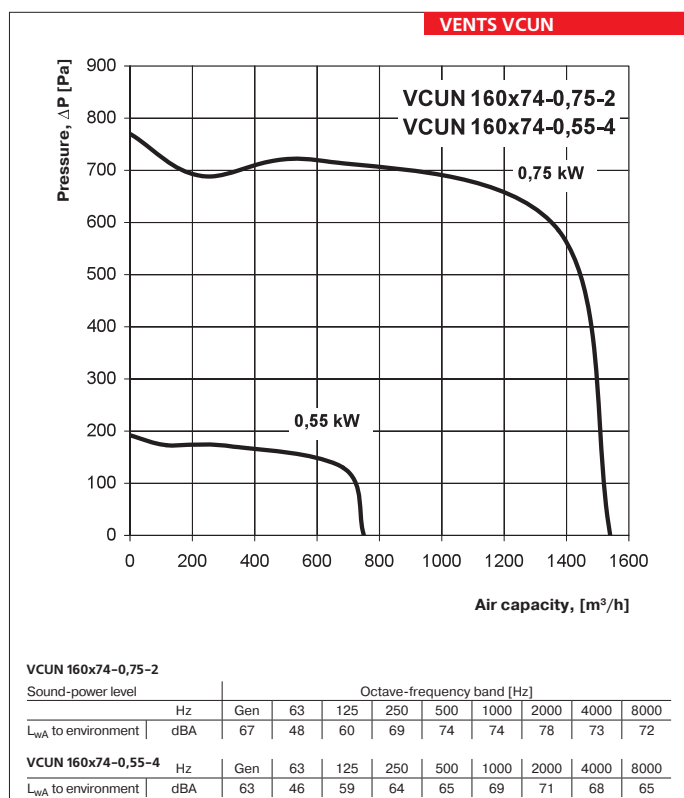
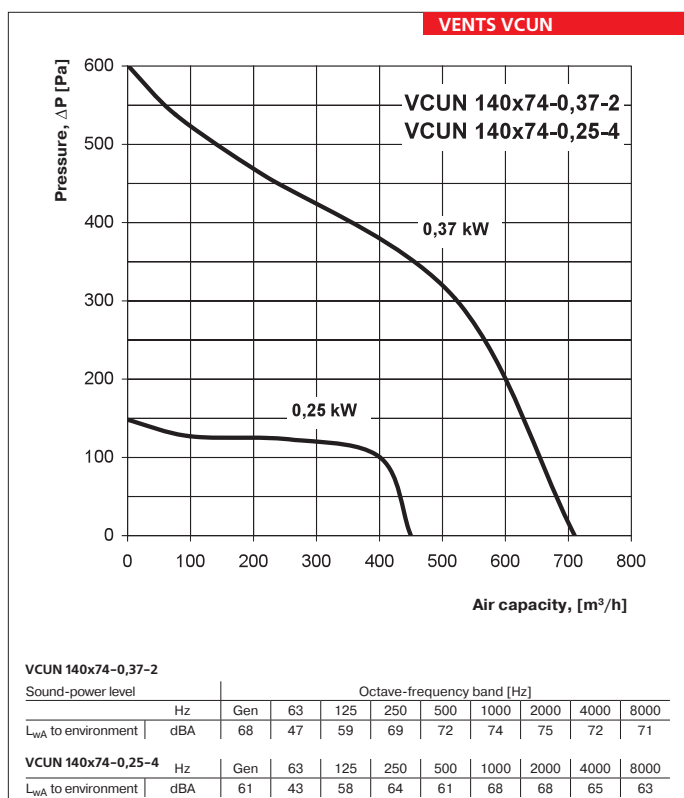

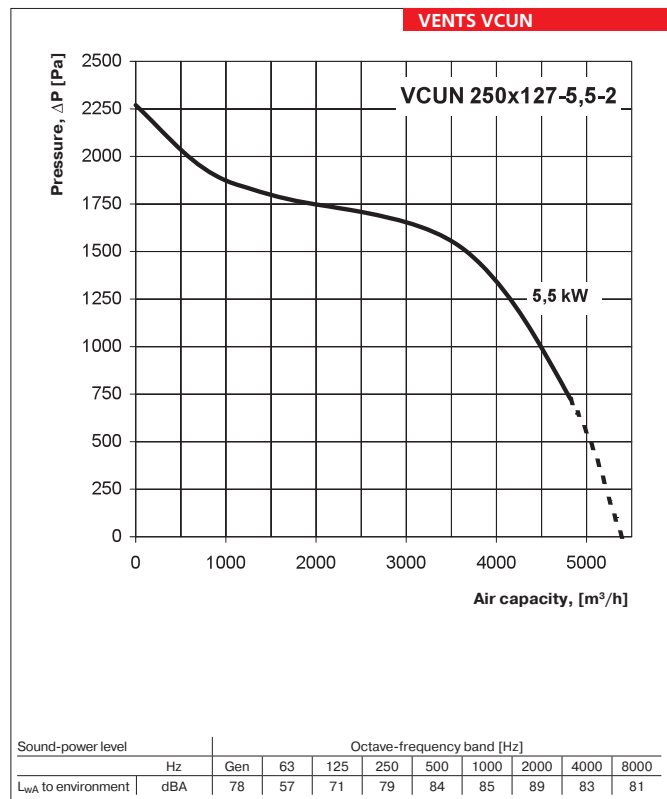
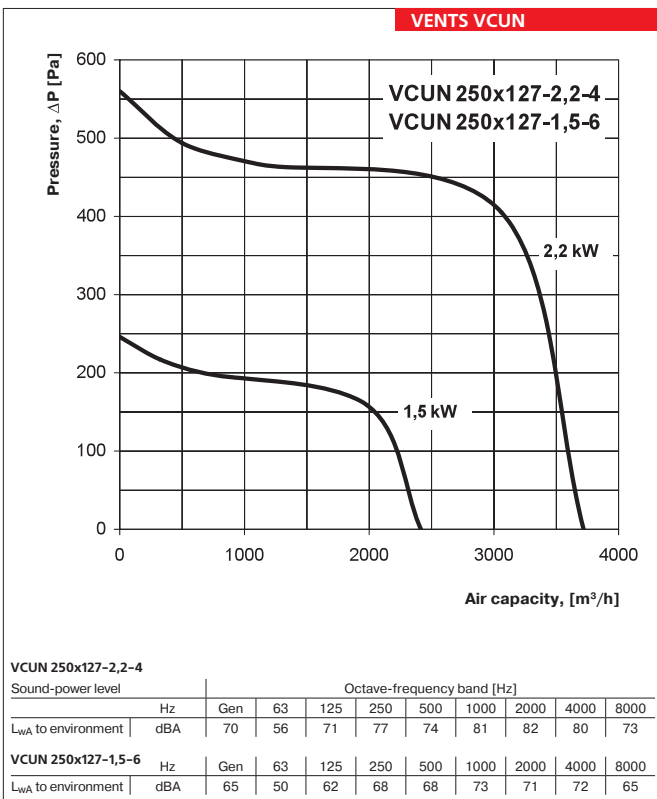
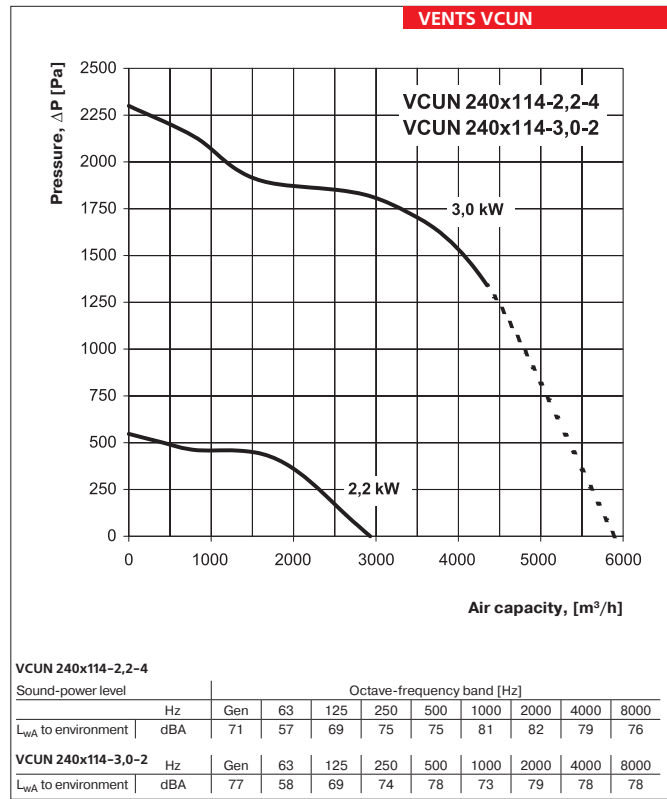
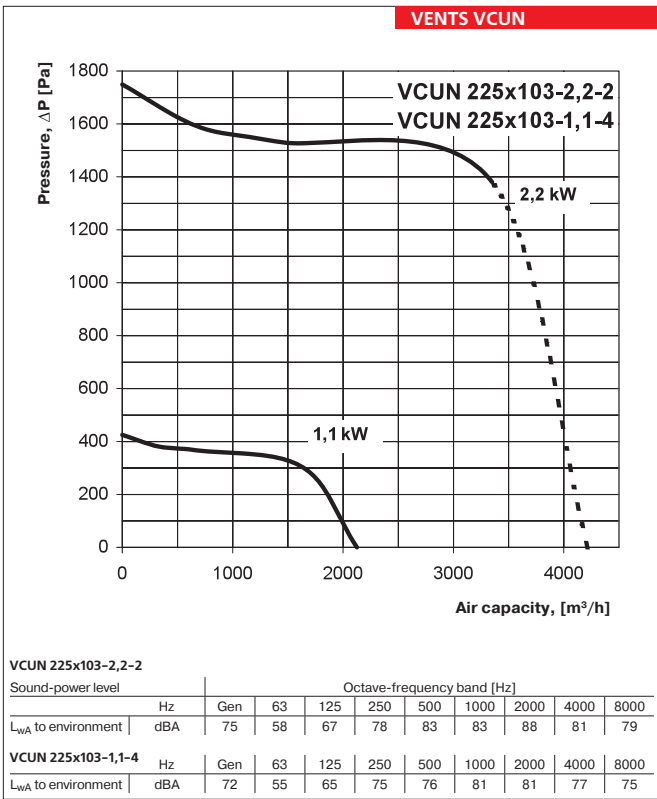

VENTS VCUN

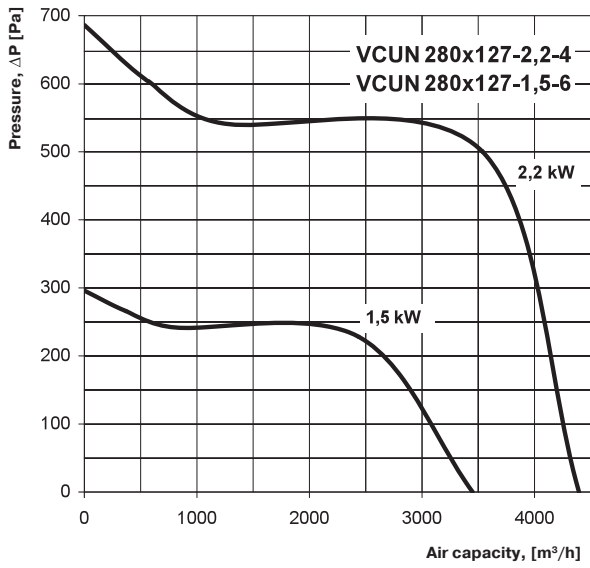

VCUN 280x127-2,2-4

Sound-power level		Octave-frequency band [Hz]								
	Hz	Gen	63	125	250	500	1000	2000	4000	8000
$L_{wA}$ to environment	dBA	73	61	74	76	81	82	83	81	77

Sound-power level		Octave-frequency band [Hz]								
	Hz	Gen	63	125	250	500	1000	2000	4000	8000
$L_{wA}$ to environment	dBA	67	50	63	69	67	73	71	69	66

VENTS VCUN

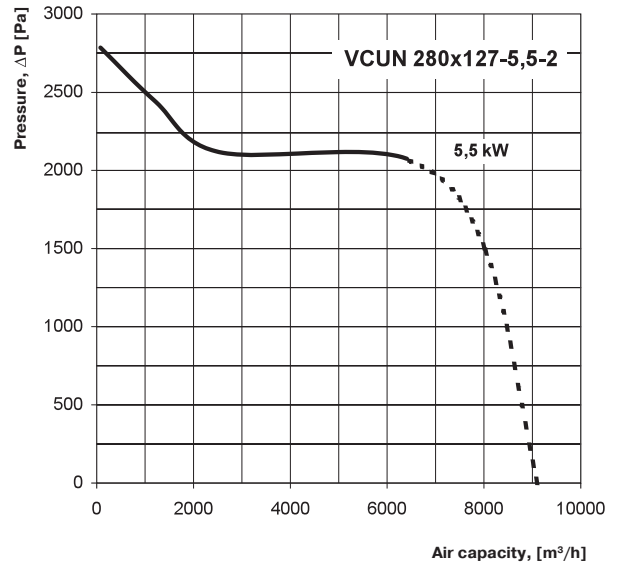

Sound-power level		Octave-frequency band [Hz]								
	Hz	Gen	63	125	250	500	1000	2000	4000	8000
$L_{wA}$ to environment	dBA	80	63	72	81	88	86	91	87	86

VENTS VCUN

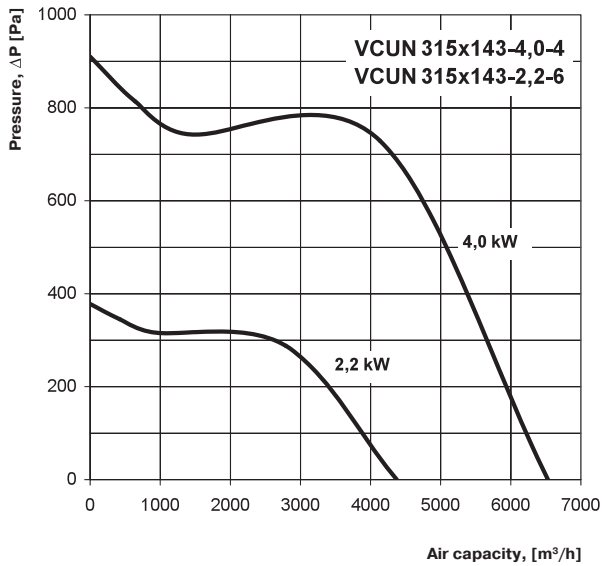

VCUN 315x143-4,0-4

Sound-power level		Octave-frequency band [Hz]								
	Hz	Gen	63	125	250	500	1000	2000	4000	8000
$L_{wA}$ to environment	dBA	78	62	73	81	84	88	86	86	83

Sound-power level		Octave-frequency band [Hz]								
	Hz	Gen	63	125	250	500	1000	2000	4000	8000
$L_{wA}$ to environment	dBA	71	56	67	70	80	78	79	72	68

VENTS VCUN

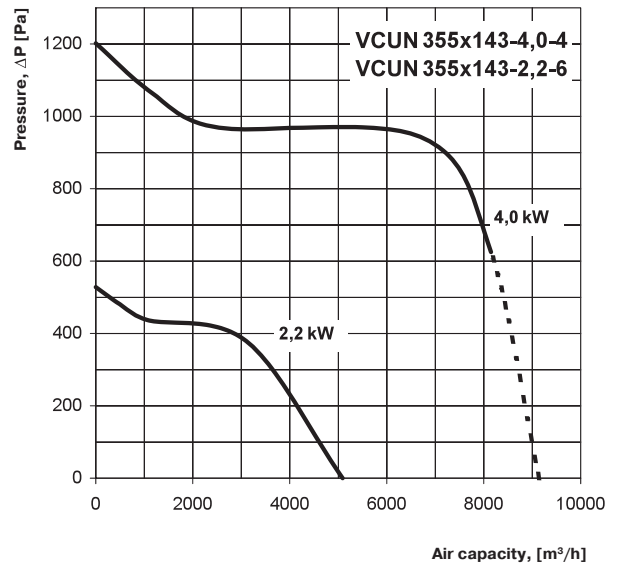

VCUN 355x143-4,0-4

Sound-power level		Octave-frequency band [Hz]								
	Hz	Gen	63	125	250	500	1000	2000	4000	8000
$L_{wA}$ to environment	dBA	77	62	75	80	84	87	90	82	82

Sound-power level		Octave-frequency band [Hz]								
	Hz	Gen	63	125	250	500	1000	2000	4000	8000
$L_{wA}$ to environment	dBA	71	54	68	73	82	82	82	75	72

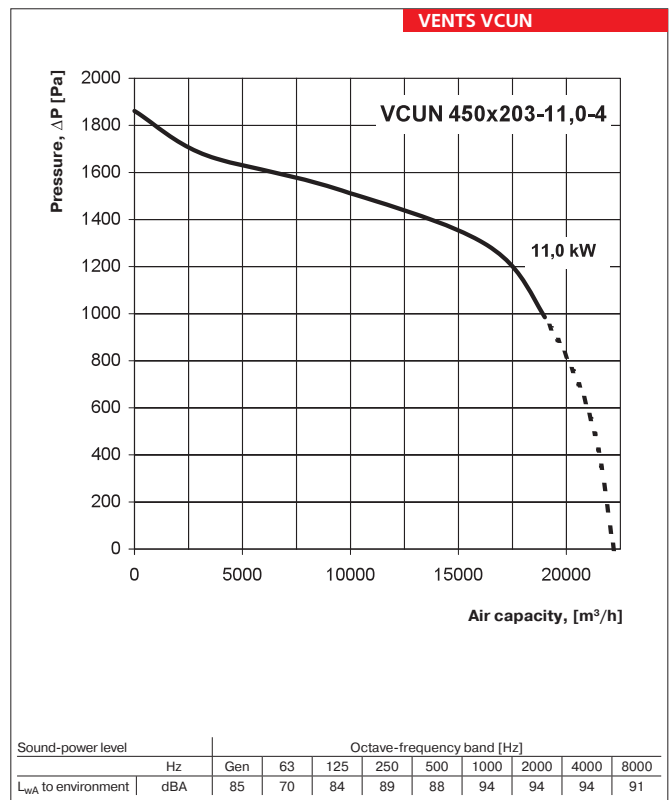
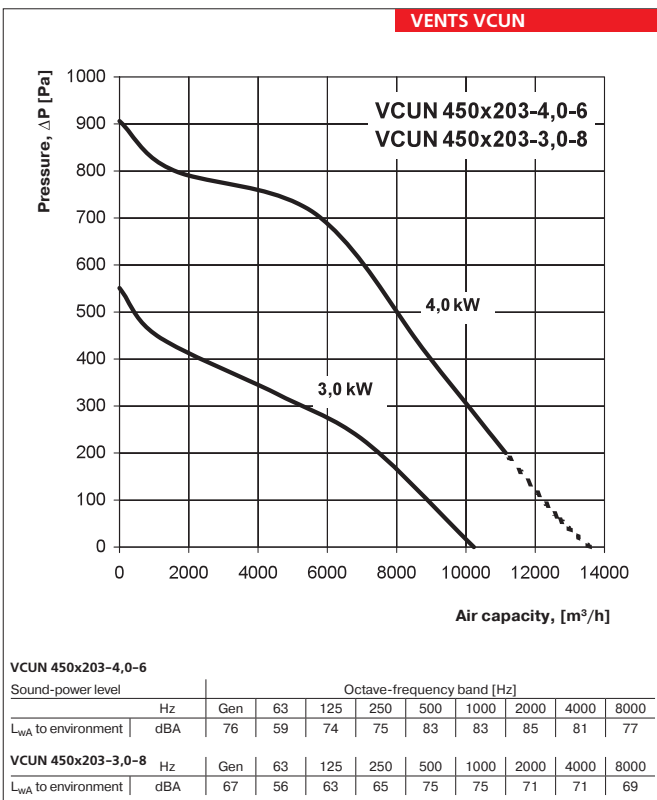
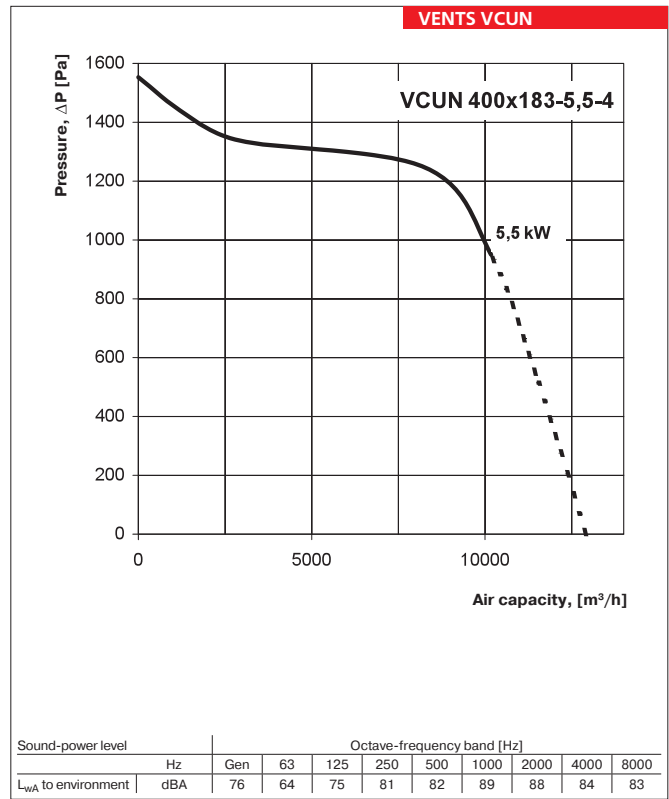
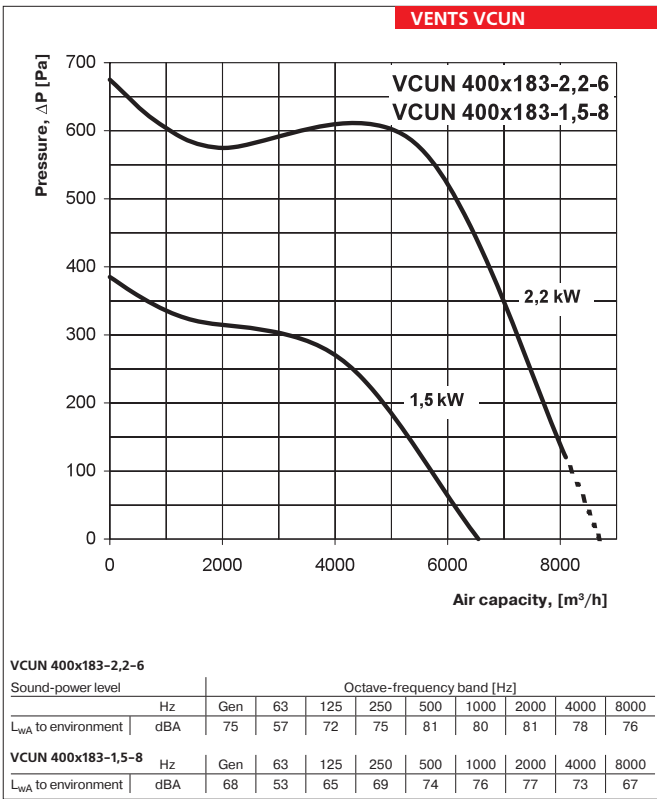

VENTS VCUN

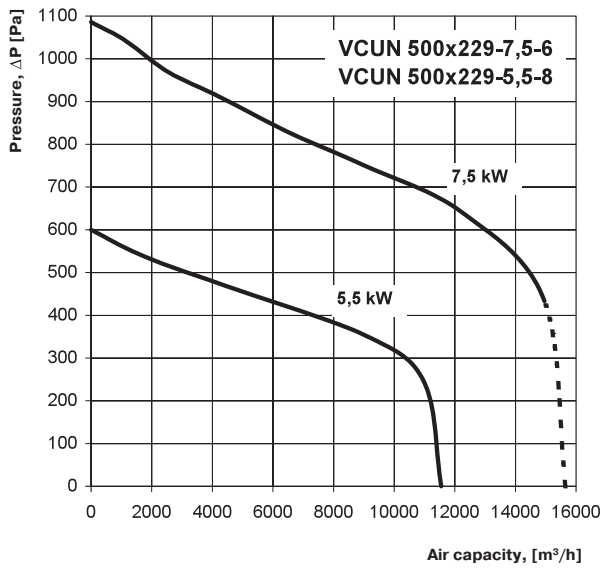

VCUN 500x229-7,5-6

Sound-power level		Octave-frequency band [Hz]									
		Hz	Gen	63	125	250	500	1000	2000	4000	8000
$L_{WA}$ to environment	dBA	83	68	79	85	85	93	92	86	85	

VCUN 500x229-5,5-8

Sound-power level		Octave-frequency band [Hz]									
		Hz	Gen	63	125	250	500	1000	2000	4000	8000
$L_{WA}$ to environment	dBA	77	61	74	78	81	86	85	81	80	

VENTS VCUN

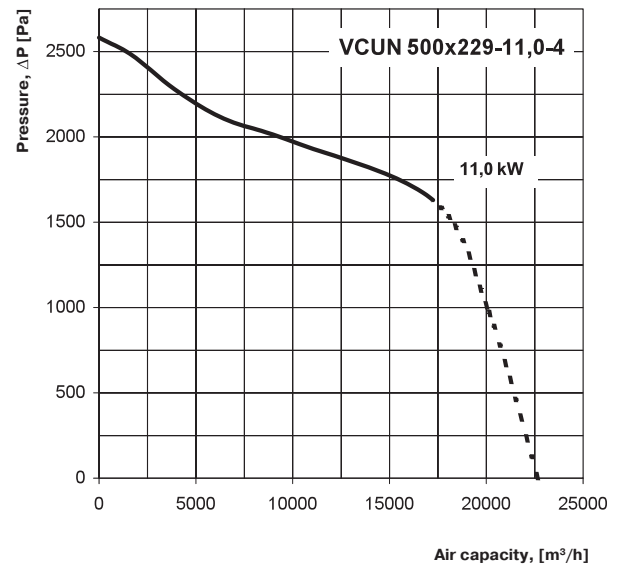

Sound-power level		Octave-frequency band [Hz]									
		Hz	Gen	63	125	250	500	1000	2000	4000	8000
$L_{WA}$ to environment	dBA	85	73	83	90	91	94	97	94	90	







# AXIAL FANS

## ▶ VENTS OV Series



- ▶ Low pressure axial fans in steel casing with the air capacity up to 11900 m<sup>3</sup>/h for wall mounting on a square mounting plate.

## ▶ VENTS OVK Series



- ▶ Low pressure axial fans in the steel casing with the air capacity up to 11900 m<sup>3</sup>/h for wall mounting on a round mounting plate.

## ▶ VENTS VKF Series



- ▶ Low pressure axial fans in steel casing with the air capacity up to 11900 m<sup>3</sup>/h for vent duct mounting.

## ▶ VENTS OV1 Series



- ▶ Low pressure axial fans in steel casing with the air capacity up to 1700 m<sup>3</sup>/h for wall mounting on a square mounting plate.

## ▶ VENTS OVK1 Series



- ▶ Low pressure axial fans in the steel casing with the air capacity up to 1700 m<sup>3</sup>/h for wall mounting on a round mounting plate.

## ▶ VENTS VKOM Series



- ▶ Low pressure axial fans in steel casing with the air capacity up to 1700 m<sup>3</sup>/h for vent duct mounting.

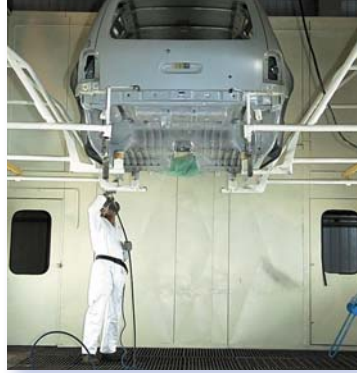

**VENTS OV**  
Axial fan

Air capacity – up to 11 900 m<sup>3</sup>/h

page  
128



**VENTS OVK**  
Axial fan

Air capacity – up to 11 900 m<sup>3</sup>/h

page  
128



**VENTS VKF**  
Axial fan

Air capacity – up to 11 900 m<sup>3</sup>/h

page  
128



**VENTS OV1**  
Axial fan

Air capacity – up to 1 700 m<sup>3</sup>/h

page  
134



**VENTS OVK1**  
Axial fan

Air capacity – up to 1 700 m<sup>3</sup>/h

page  
134



**VENTS VKOM**  
Axial fan

Air capacity – up to 1 700 m<sup>3</sup>/h

page  
134

Series  
**VENTS OV**



Low pressure axial fans in the steel casing with the air capacity up to **11900 m<sup>3</sup>/h** for wall mounting.

Series  
**VENTS OVK**



Low pressure axial fans in the steel casing with the air capacity up to **11900 m<sup>3</sup>/h** for wall mounting.

Series  
**VENTS VKF**



Low pressure axial fans in the steel casing with the air capacity up to **11900 m<sup>3</sup>/h** for vent duct mounting.

■ **Applications**

Combined supply and exhaust ventilation systems for various premises where high air capacity at relatively low system resistance is required. OV and OVK fans can be used for the direct air exhaust or pressurization in smoke ventilation systems. OV and OVK fan are suitable for outdoor wall mounting.

■ **Design**

The fan casing and the impeller are made of steel with polymeric coating. OV and OVK fan terminal box is equipped with the cord for remote connection. VKF fan is fitted with the external terminal box mounted on the fan casing.

■ **Motor**

The impellers are powered by two- or three-pole, single- or three-phase asynchronous motors with external rotor and built-in thermal overheating protection depending on the model. Ball bearings in the motor provide long service life designed for at least 40 000 hours. Motor protection rating IP 44.

■ **Speed control**

Both smooth or step speed control is performed by means of the thymistor or autotransformer controller. Several fans can be connected to one controller if the total power and operating current do not exceed the rated controller values.

■ **Mounting**

Fan is installed on the wall surface by means of a square (OV series) or round (OVK series) mounting plate. VKF fan is installed into the duct by means of connecting flanges. The fan is powered through the external remote terminal box. Power supply and installation shall be performed in compliance with the manual and wiring diagram on the terminal box.

**Designation key:** \_\_\_\_\_

Series and modification	Motor modification		Flange diameter
<b>VENTS OV</b> – with a square mounting plate	Number of poles	Phase	200; 250; 300; 350; 400; 450; 500; 550; 630
<b>VENTS OVK</b> – with a round mounting plate	2	E – single phase	
<b>VENTS VKF</b> – for mounting into a vent duct	4	D – three phases	

**Accessories**



page 301



page 310



page 310



page 311



page 314



page 315



**Technical data:**

single-phase fans

	<b>OV / OVK / VKF 2E 200</b>	<b>OV / OVK / VKF 2E 250</b>	<b>OV / OVK / VKF 4E 250</b>	<b>OV / OVK / VKF 2E 300</b>	<b>OV / OVK / VKF 4E 300</b>	<b>OV / OVK / VKF 4E 350</b>
Voltage [V / 50 Hz]	230	230	230	230	230	230
Power [W]	55	80	50	145	75	140
Current [A]	0,26	0,4	0,22	0,66	0,35	0,65
Maximum air flow [m <sup>3</sup> /h]	860	1050	800	2230	1340	2500
RPM [min <sup>-1</sup> ]	2300	2400	1380	2300	1350	1380
Noise level at 3 m [dBA]	50	60	55	60	58	62
Maximum operating temperature [°C]	-30 +60	-30 +60	-30 +60	-30 +60	-30 +60	-30 +60
Protection rating	IP 24 (VKF IP X4)	IP 24 (VKF IP X4)	IP 24 (VKF IP X4)	IP 24 (VKF IP X4)	IP 24 (VKF IP X4)	IP 24 (VKF IP X4)

**Technical data:**

single-phase fans

	<b>OV / OVK / VKF 4E 400</b>	<b>OV / OVK / VKF 4E 450</b>	<b>OV / OVK / VKF 4E 500</b>	<b>OV / OVK / VKF 4E 550</b>	<b>OV / OVK / VKF 4E 630</b>
Voltage [V / 50 Hz]	230	230	230	230	230
Power [W]	180	250	420	550	750
Current [A]	0,82	1,2	1,95	2,55	3,5
Maximum air flow [m <sup>3</sup> /h]	3580	4680	7060	8800	11900
RPM [min <sup>-1</sup> ]	1380	1350	1300	1300	1360
Noise level at 3 m [dBA]	63	64	69	70	75
Maximum operating temperature [°C]	-30 +60	-30 +60	-30 +60	-30 +60	-30 +60
Protection rating	IP 24 (VKF IP X4)	IP 24 (VKF IP X4)	IP 24 (VKF IP X4)	IP 24 (VKF IP X4)	IP 24 (VKF IP X4)

**Technical data:**

three-phase fans

	<b>OV / OVK / VKF 2D 250</b>	<b>OV / OVK / VKF 4D 250</b>	<b>OV / OVK / VKF 2D 300</b>	<b>OV / OVK / VKF 4D 300</b>	<b>OV / OVK / VKF 4D 350</b>	<b>OV / OVK / VKF 4D 400</b>	<b>OV / OVK / VKF 4D 450</b>
Voltage [V / 50 Hz]	400	400	400	400	400	400	400
Power [W]	80	60	145	75	140	180	250
Current [A]	0,22	0,17	0,25	0,22	0,38	0,47	0,6
Maximum air flow [m <sup>3</sup> /h]	1060	850	2310	1310	2520	3740	5280
RPM [min <sup>-1</sup> ]	2600	1400	2350	1380	1380	1380	1360
Noise level at 3 m [dBA]	60	55	60	58	62	64	65
Maximum operating temperature [°C]	-30 +60	-30 +60	-30 +60	-30 +60	-30 +60	-30 +60	-30 +60
Protection rating	IP 24 (VKF IP X4)	IP 24 (VKF IP X4)	IP 24 (VKF IP X4)	IP 24 (VKF IP X4)	IP 24 (VKF IP X4)	IP 24 (VKF IP X4)	IP 24 (VKF IP X4)



OV fan boiler room ventilation example.



VFK series fan installation into the vent duct by means of flanges.



## AXIAL FANS

### Fan overall dimensions:

Type	Dimensions [mm]					Mass [kg]
	∅D	∅d	B	B1	L	
OV 2E 200	210	7	312	260	145	3,0
OV 2E 250	260	7	370	320	155	4,0
OV 4E 250	260	7	370	320	155	3,5
OV 2E 300	326	9	430	380	195	6,1
OV 4E 300	326	9	430	380	195	5,0
OV 4E 350	388	9	485	435	200	7,8
OV 4E 400	417	9	540	490	240	8,8
OV 4E 450	465	11	576	535	250	10,5
OV 4E 500	520	11	655	615	260	14,0
OV 4E 550	570	11	725	675	280	16,5
OV 4E 630	650	11	800	710	295	20,0
OV 2D 250	260	7	370	320	155	4,0
OV 4D 250	260	7	370	320	155	3,5
OV 2D 300	326	9	430	380	155	5,4
OV 4D 300	326	9	430	380	155	5,4
OV 4D 350	388	9	485	435	200	7,8
OV 4D 400	417	9	540	490	240	8,8
OV 4D 450	465	11	576	535	250	10,5

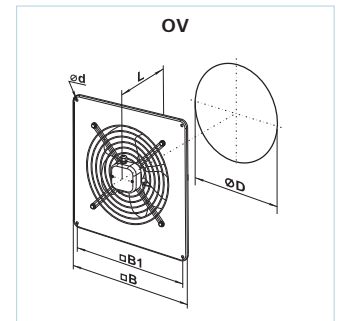

### Fan overall dimensions:

Type	Dimensions [mm]					Mass [kg]
	∅D	∅D1	∅D2	∅d	L	
OVK 2E 200	210	250	280	7	145	2,8
OVK 2E 250	260	295	320	7	155	3,8
OVK 4E 250	260	295	320	7	155	3,4
OVK 2E 300	326	380	397	9	195	5,9
OVK 4E 300	326	380	397	9	195	5,0
OVK 4E 350	388	442	460	9	200	7,5
OVK 4E 400	417	504	528	9	240	8,5
OVK 4E 450	465	578	607	11	250	10,0
OVK 4E 500	520	590	655	11	260	14,0
OVK 4E 550	570	645	710	11	280	16,5
OVK 4E 630	650	760	800	11	295	20,0
OVK 2D 250	260	295	320	7	155	3,8
OVK 4D 250	260	295	320	7	155	3,4
OVK 2D 300	326	380	397	9	155	5,1
OVK 4D 300	326	380	397	9	155	5,1
OVK 4D 350	388	442	460	9	200	7,5
OVK 4D 400	417	504	528	9	240	8,5
OVK 4D 450	465	578	607	11	250	10,0

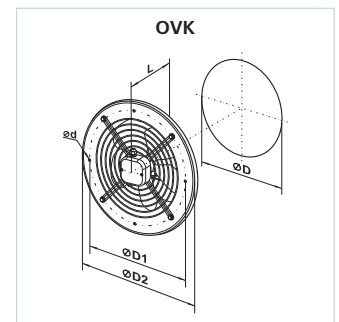

### Fan overall dimensions:

Type	Dimensions [mm]						Mass [kg]
	∅D	∅D1	∅D2	∅d	B	L	
VKF 2E 200	205	250	280	7	290	120	3,1
VKF 2E 250	260	295	320	7	340	150	4,0
VKF 4E 250	260	295	320	7	340	150	4,1
VKF 2E 300	310	380	397	9	420	160	6,5
VKF 4E 300	310	380	397	9	420	160	6,5
VKF 4E 350	362	442	460	9	480	160	8,1
VKF 4E 400	412	504	528	9	550	170	9,1
VKF 4E 450	462	578	607	11	630	200	10,6
VKF 4E 500	515	600	650	11	635	220	12,8
VKF 4E 550	565	650	700	13	685	230	15,5
VKF 4E 630	645	740	790	13	780	230	18,5
VKF 2D 250	260	295	320	7	340	150	4,0
VKF 4D 250	260	295	320	7	340	150	4,1
VKF 2D 300	310	380	397	9	420	160	6,0
VKF 4D 300	310	380	397	9	420	160	6,0
VKF 4D 350	362	442	460	9	480	160	8,1
VKF 4D 400	412	504	528	9	550	170	9,1
VKF 4D 450	462	578	607	11	630	200	10,6

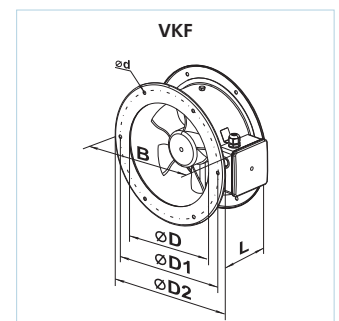

VENTS OV / OVK / VKF

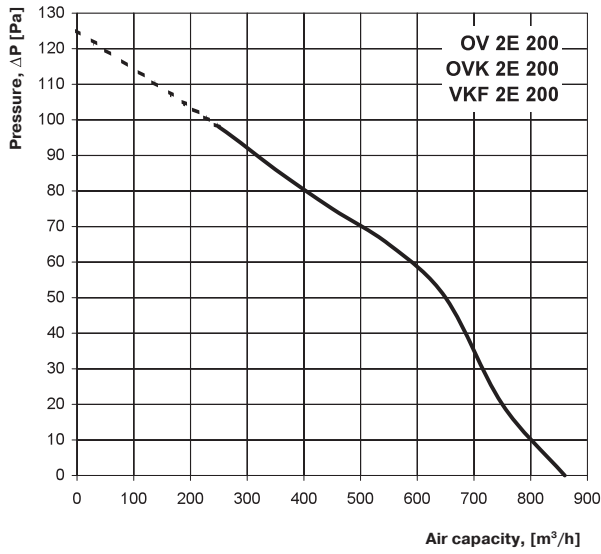

Sound-power level		Octave-frequency band [Hz]								
Hz	Gen	63	125	250	500	1000	2000	4000	8000	
$L_{WA}$ to environment	dBA	65	56	58	58	57	59	55	51	45

VENTS OV / OVK / VKF

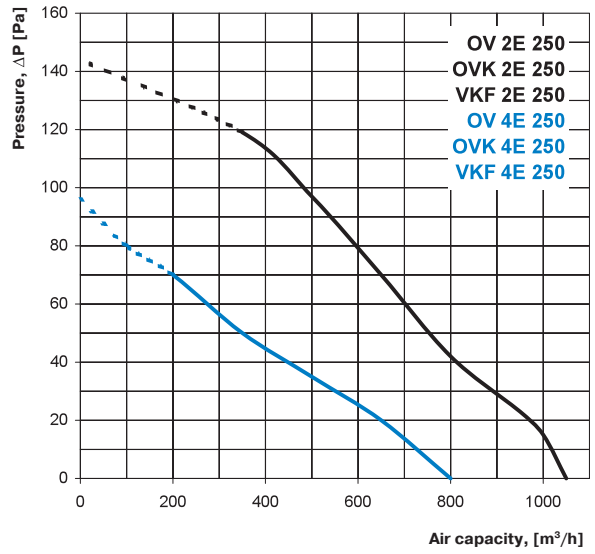

Sound-power level		Octave-frequency band [Hz]								
Hz	Gen	63	125	250	500	1000	2000	4000	8000	
$L_{WA}$ to environment	dBA	76	68	66	68	70	68	68	63	58

Sound-power level		Octave-frequency band [Hz]								
Hz	Gen	63	125	250	500	1000	2000	4000	8000	
$L_{WA}$ to environment	dBA	60	52	50	52	53	52	52	44	43

VENTS OV / OVK / VKF

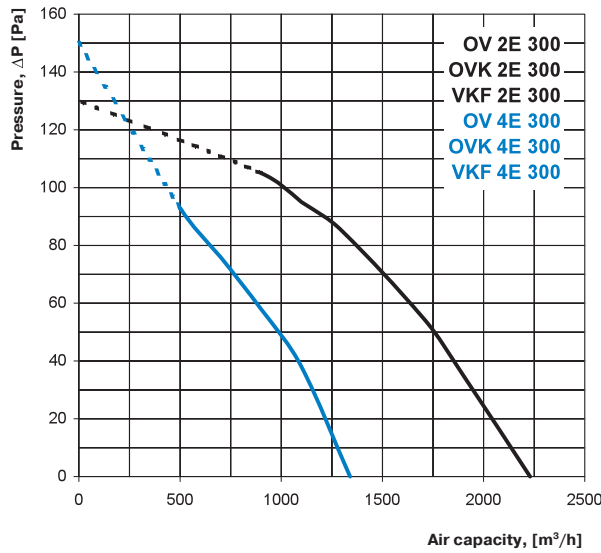

Sound-power level		Octave-frequency band [Hz]								
Hz	Gen	63	125	250	500	1000	2000	4000	8000	
$L_{WA}$ to environment	dBA	78	72	72	70	72	70	69	63	63

Sound-power level		Octave-frequency band [Hz]								
Hz	Gen	63	125	250	500	1000	2000	4000	8000	
$L_{WA}$ to environment	dBA	67	58	57	59	57	58	53	52	49

VENTS OV / OVK / VKF

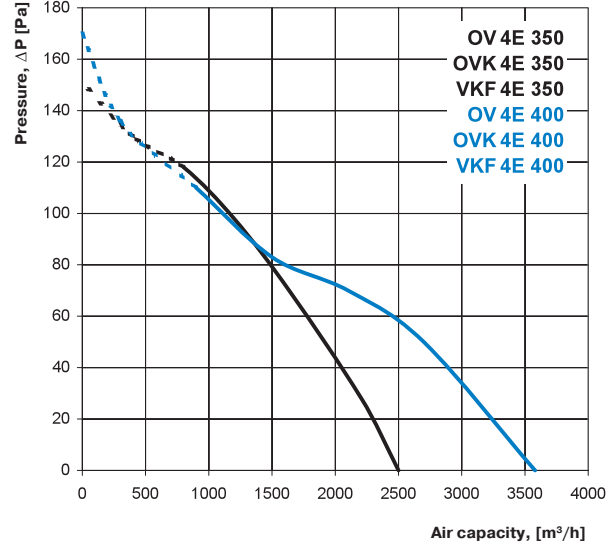

Sound-power level		Octave-frequency band [Hz]								
Hz	Gen	63	125	250	500	1000	2000	4000	8000	
$L_{WA}$ to environment	dBA	70	61	62	64	63	63	58	56	52

Sound-power level		Octave-frequency band [Hz]								
Hz	Gen	63	125	250	500	1000	2000	4000	8000	
$L_{WA}$ to environment	dBA	75	66	68	66	69	67	65	61	56

VENTS OV  
 VENTS OVK  
 VENTS VKF  
 FAN SERIES

VENTS OV / OVK / VKF

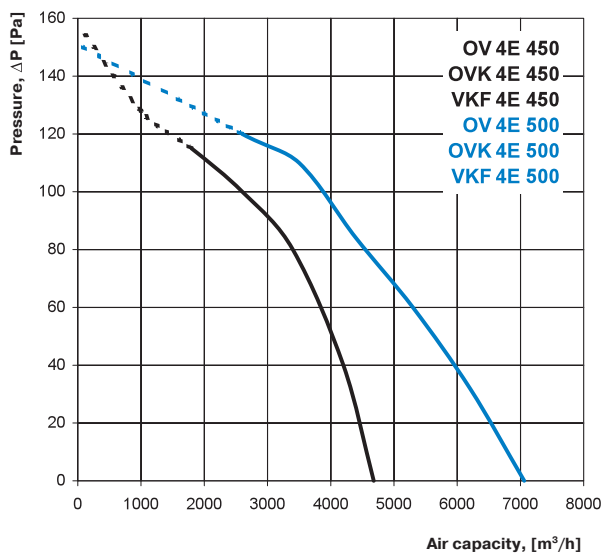

OV / OVK / VKF 4E 450

Sound-power level	Hz	Octave-frequency band [Hz]								
		Gen	63	125	250	500	1000	2000	4000	8000
L <sub>WA</sub> to environment	dBA	77	69	70	73	73	71	67	67	61

OV / OVK / VKF 4E 500

Sound-power level	Hz	Octave-frequency band [Hz]								
		Gen	63	125	250	500	1000	2000	4000	8000
L <sub>WA</sub> to environment	dBA	80	71	73	72	74	73	70	67	63

VENTS OV / OVK / VKF

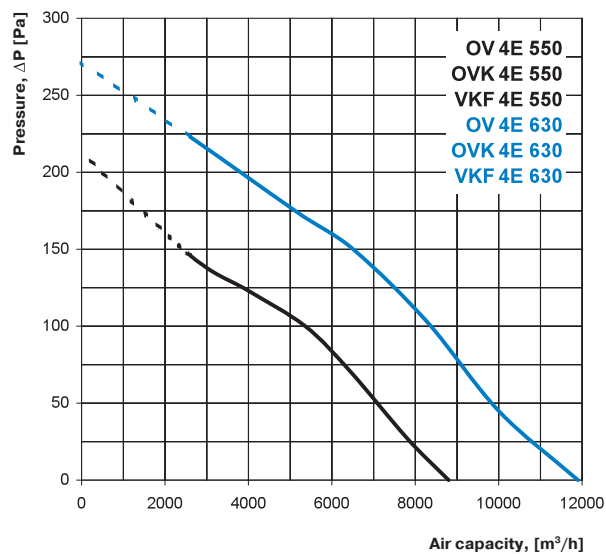

OV / OVK / VKF 4E 550

Sound-power level	Hz	Octave-frequency band [Hz]								
		Gen	63	125	250	500	1000	2000	4000	8000
L <sub>WA</sub> to environment	dBA	83	73	75	73	75	74	72	66	63

OV / OVK / VKF 4E 630

Sound-power level	Hz	Octave-frequency band [Hz]								
		Gen	63	125	250	500	1000	2000	4000	8000
L <sub>WA</sub> to environment	dBA	77	71	73	72	73	71	70	63	59

VENTS OV / OVK / VKF

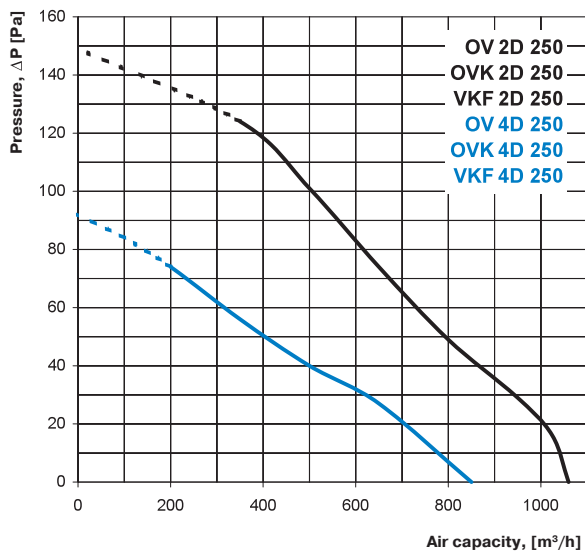

OV / OVK / VKF 2D 250

Sound-power level	Hz	Octave-frequency band [Hz]								
		Gen	63	125	250	500	1000	2000	4000	8000
L <sub>WA</sub> to environment	dBA	77	67	68	70	69	68	66	60	57

OV / OVK / VKF 4D 250

Sound-power level	Hz	Octave-frequency band [Hz]								
		Gen	63	125	250	500	1000	2000	4000	8000
L <sub>WA</sub> to environment	dBA	60	49	50	53	54	53	52	45	42

VENTS OV / OVK / VKF

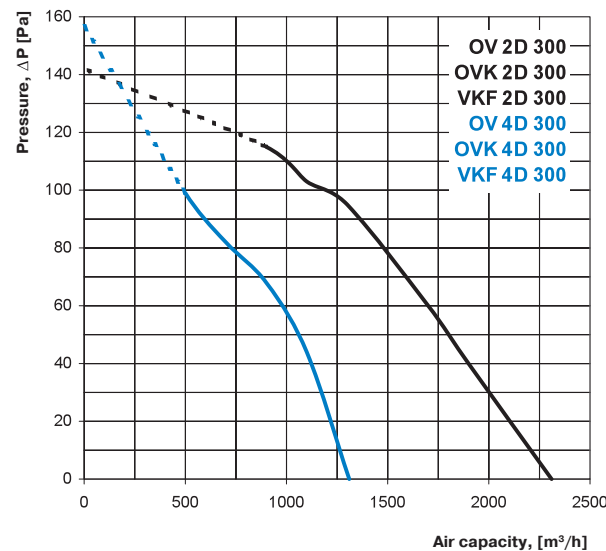

OV / OVK / VKF 2D 300

Sound-power level	Hz	Octave-frequency band [Hz]								
		Gen	63	125	250	500	1000	2000	4000	8000
L <sub>WA</sub> to environment	dBA	80	72	71	71	74	70	69	65	63

OV / OVK / VKF 4D 300

Sound-power level	Hz	Octave-frequency band [Hz]								
		Gen	63	125	250	500	1000	2000	4000	8000
L <sub>WA</sub> to environment	dBA	63	58	55	58	56	58	57	52	48

**VENTS OV / OVK / VKF**

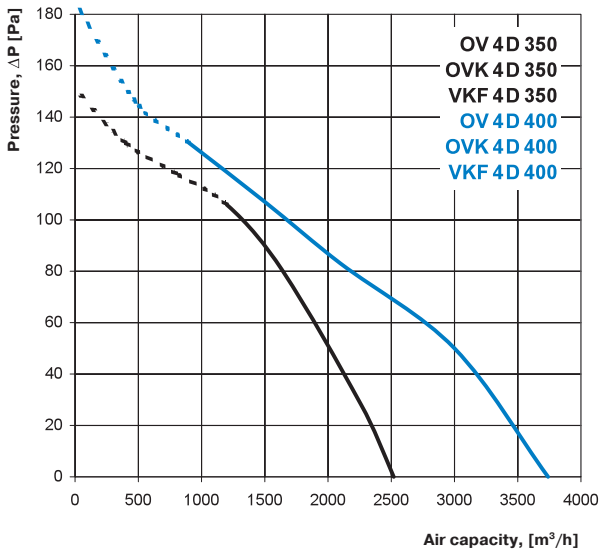

**OV / OVK / VKF 4D 350**

Sound-power level		Octave-frequency band [Hz]								
	Hz	Gen	63	125	250	500	1000	2000	4000	8000
$L_{WA}$ to environment	dB(A)	72	62	61	64	64	61	61	56	54

**OV / OVK / VKF 4D 400**

Sound-power level		Octave-frequency band [Hz]								
	Hz	Gen	63	125	250	500	1000	2000	4000	8000
$L_{WA}$ to environment	dB(A)	75	65	66	69	66	67	64	60	55

**VENTS OV / OVK / VKF**

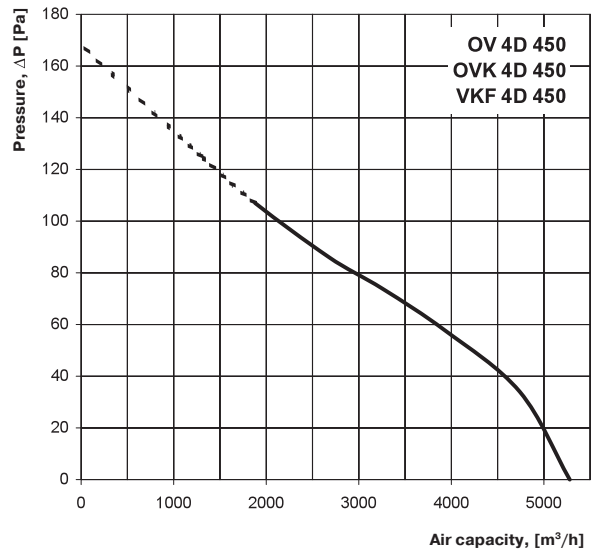

**OV / OVK / VKF 4D 450**

Sound-power level		Octave-frequency band [Hz]								
	Hz	Gen	63	125	250	500	1000	2000	4000	8000
$L_{WA}$ to environment	dB(A)	76	65	68	69	69	70	64	60	57

**VENTS OV**  
**VENTS OVK**  
**VENTS VKF**  
 FAN SERIES

Series  
**VENTS OV1**



Low pressure axial fans in the steel casing with the air capacity up to **1700 m<sup>3</sup>/h** for wall mounting.

Series  
**VENTS OVK1**



Low pressure axial fans in the steel casing with the air capacity up to **1700 m<sup>3</sup>/h** for wall mounting.

Series  
**VENTS VKOM**



Low pressure axial fans in the steel casing with the air capacity up to **1700 m<sup>3</sup>/h** for mounting into the vent duct

■ **Applications**

Combined supply and extract ventilation systems for various premises where high air capacity at relatively low system resistance is required. OV1 and OVK1 fans can be used for the direct exhaust of air. OV1 and OVK1 fans can be mounted onto the external walls.

■ **Design**

OV1, OVK1 and VKOM fan casings are made of steel with polymeric coating. VKOMz fan casing is made of galvanized steel and the impeller is made of aluminium. The terminal box is fitted with a cord for remote connection.

■ **Motor**

Single-phase asynchronous motor with external rotor is equipped with thermal overheating protection with automatic restart as well as ball bearings for long service life. Motor rating protection IP 44.

■ **Speed control**

Both smooth and step speed control is performed with the thyristor or autotransformer controller. Several fans can be connected to one controller in case the total power and operating current do not exceed the rated controller values.

■ **Mounting**

The fan is installed on the wall surface by means of square (OV1 series) or round (OVK1 series) mounting plate. VKOM or VKOMz series fan is installed into the duct by means of clamps or directly inside the wall. The delivery set of VKOMz includes fixation brackets. The fan is powered through the remote terminal box. Power supply and installation shall be performed in compliance with the manual and wiring diagram on the terminal box.

**Designation key:** \_\_\_\_\_

Series and modification	Modifications (for VKOM series)	Flange diameter
<b>VENTS OV1</b> – with a square mounting plate <b>VENTS OVK1</b> – with a round mounting plate <b>VENTS VKOM</b> – for mounting into a vent duct	Z – galvanized steel	150; 200; 250; 315

**Accessories** \_\_\_\_\_



page 310



page 310



page 311



page 314



page 315



**Technical data:**

	<b>OV1 / OVK1 / VKOM 150</b>	<b>OV1 / OVK1 / VKOM 200</b>	<b>OV1 / OVK1 / VKOM 250</b>	<b>OV1 / OVK1 / VKOM 315</b>
Voltage [V / 50 Hz]	230	230	230	230
Power [W]	36	43	68	110
Current [A]	0,26	0,28	0,48	0,75
Maximum air flow [m <sup>3</sup> /h]	200	405	1070	1700
RPM [min <sup>-1</sup> ]	1300	1300	1300	1300
Noise level at 3 m [dBA]	33	32	48	54
Maximum operating temperature [°C]	40	40	40	40
Protection rating	IP 24 (VKOM IP X4)	IP 24 (VKOM IP X4)	IP 24 (VKOM IP X4)	IP 24 (VKOM IP X4)



Fixation bracket for surface mounting of VKOM (VKOMz) series fan.

VENTS OV1  
 VENTS OVK1  
 VENTS VKOM  
 FAN SERIES



OV1 fan kitchen ventilation example.

Fan overall dimensions:

Type	Dimensions [mm]					Mass [kg]
	∅D	∅d	B	B1	L	
OV1 150	162	7	250	210	120	2,5
OV1 200	208	7	312	260	120	3,0
OV1 250	262	7	370	320	140	3,5
OV1 315	312	9	430	380	170	6,1

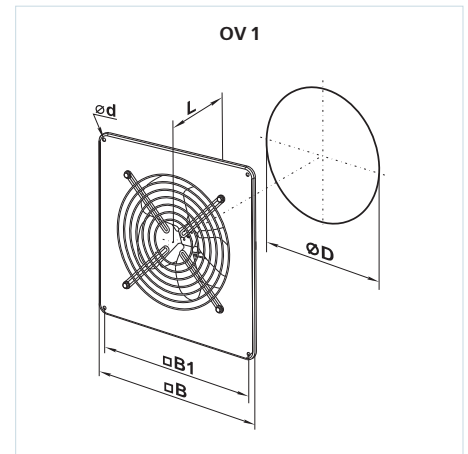

Fan overall dimensions:

Type	Dimensions [mm]					Mass [kg]
	∅D	∅D1	∅D2	∅d	L	
OVK1 150	162	190	220	7	120	2,5
OVK1 200	208	270	300	7	120	2,5
OVK1 250	262	330	360	7	140	3,0
OVK1 315	312	390	420	9	170	5,1

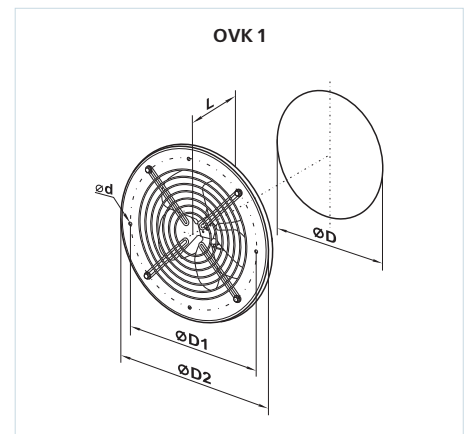

Fan overall dimensions:

Type	Dimensions [mm]					Mass [kg]
	∅D	B	L	L1	L3	
VKOM 150	162	183	220	40	30	1,8
VKOM 200	208	228	220	40	30	2,4
VKOM 250	262	283	270	55	30	3,7
VKOM 315	315	337	278	55	40	4,9

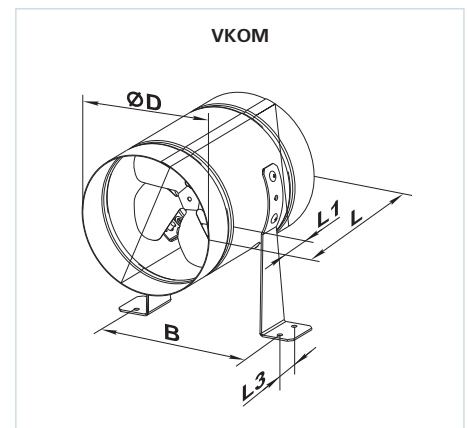

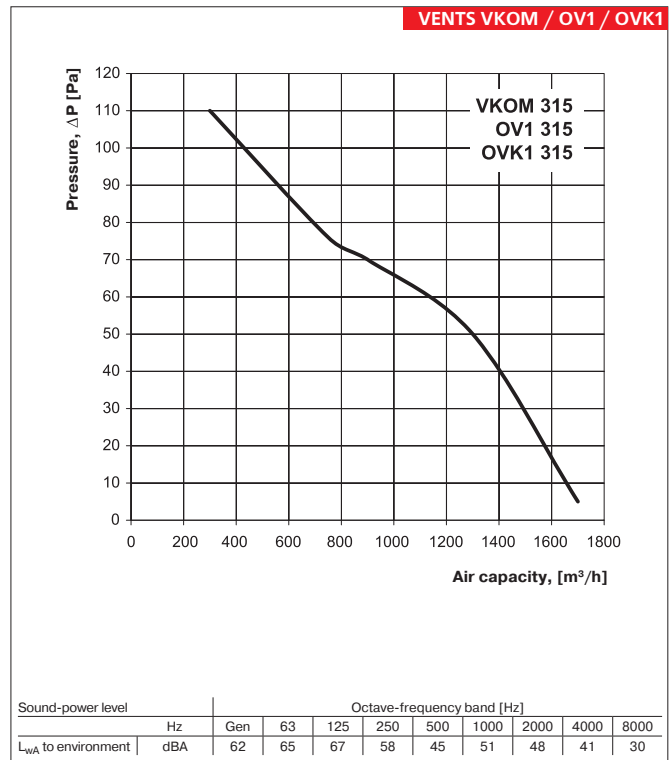
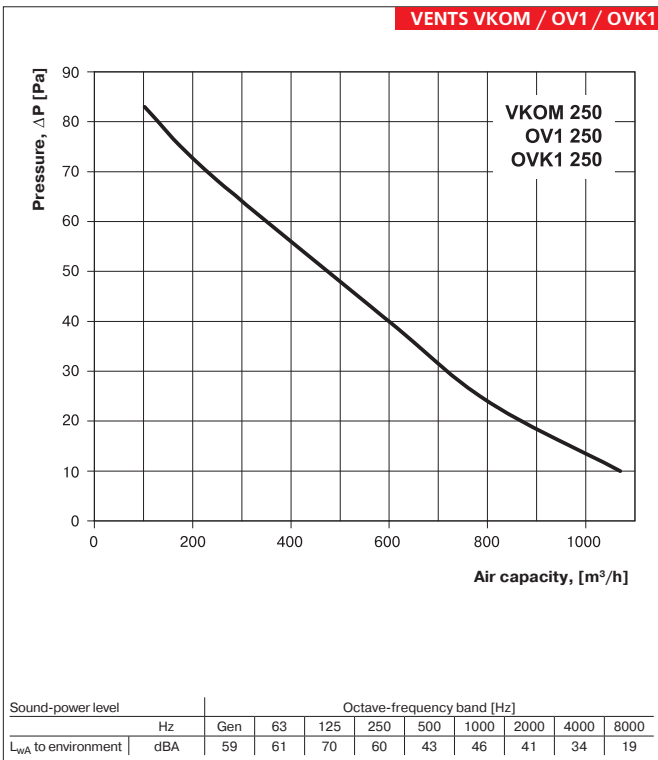
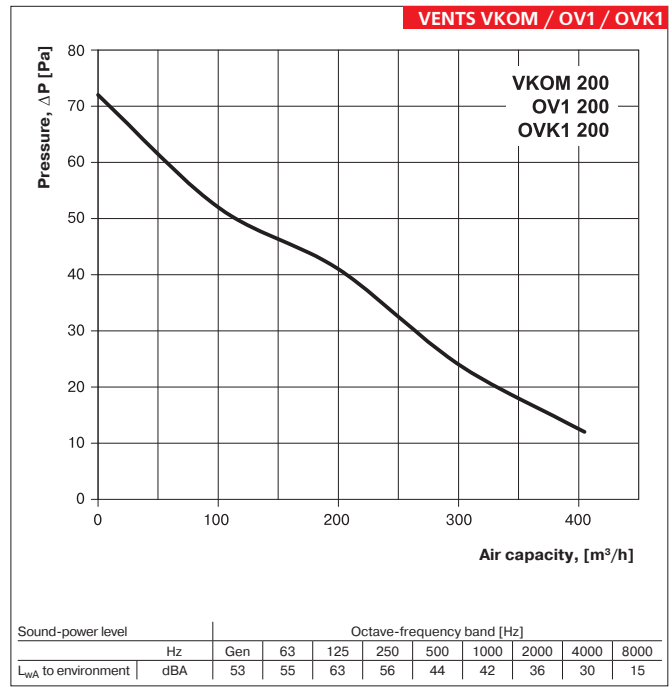
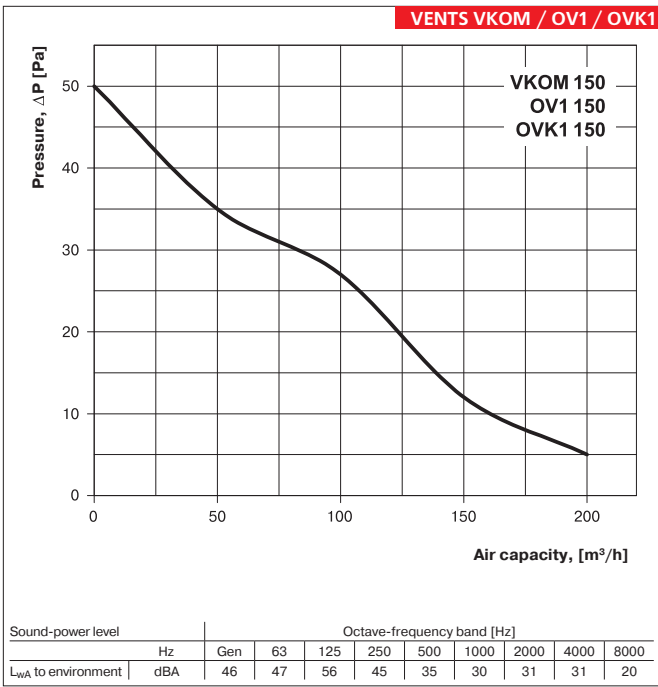

**VENTS OV1**  
**VENTS OVK1**  
**VENTS VKOM**  
 FAN SERIES

# ELECTRICAL ACCESSORIES COMPATIBILITY



		OV 2E 200	OV 2E 250	OV 4E 250	OV 2E 300	OV 4E 300	OV 2E 350	OV 4E 350	OV 2E 400	OV 4E 400	OV 2E 450	OV 4E 450	OV 2E 500	OV 4E 500	OV 2E 550	OV 4E 550	OV 2E 630	OV 4E 630	OV 2D 250	OV 4D 250	OV 2D 300	OV 4D 300	OV 2D 350	OV 4D 350	OV 2D 400	OV 4D 400	OV 2D 450	OV 4D 450	
<b>Thyristor speed controllers</b>																													
	RS-1-300	•	•	•	•	•	•	•	•	•	•	•																	
	RS-1-400	•	•	•	•	•	•	•	•	•	•	•																	
	RS-1 N (V)	•	•	•	•	•	•	•	•	•	•	•																	
	RS-1,5 N (V)	•	•	•	•	•	•	•	•	•	•	•																	
	RS-2 N (V)	•	•	•	•	•	•	•	•	•	•	•	•																
	RS-2,5 N (V)	•	•	•	•	•	•	•	•	•	•	•	•																
	RS-0,5-PS	•	•	•	•	•	•	•	•	•	•	•																	
	RS-1,5-PS	•	•	•	•	•	•	•	•	•	•	•																	
	RS-2,5-PS	•	•	•	•	•	•	•	•	•	•	•	•																
	RS-4,0-PS	•	•	•	•	•	•	•	•	•	•	•	•																
	RS-1,5-T	•	•	•	•	•	•	•	•	•	•	•																	
	RS-3,0-T	•	•	•	•	•	•	•	•	•	•	•																	
	RS-5,0-T	•	•	•	•	•	•	•	•	•	•	•																	
	RS-10,0-T	•	•	•	•	•	•	•	•	•	•	•																	
	RS-1,5-TA	•	•	•	•	•	•	•	•	•	•	•																	
	RS-3,0-TA	•	•	•	•	•	•	•	•	•	•	•																	
	RS-5,0-TA	•	•	•	•	•	•	•	•	•	•	•																	
	RS-10,0-TA	•	•	•	•	•	•	•	•	•	•	•																	
<b>Transformer speed controllers</b>																													
	RSA5E-2-P	•	•	•	•	•	•	•	•	•	•	•																	
	RSA5E-2-M	•	•	•	•	•	•	•	•	•	•	•																	
	RSA5E-3-M	•	•	•	•	•	•	•	•	•	•	•																	
	RSA5E-4-M	•	•	•	•	•	•	•	•	•	•	•																	
	RSA5E-12-M	•	•	•	•	•	•	•	•	•	•	•																	
	RSA5E-1,5-T	•	•	•	•	•	•	•	•	•	•	•																	
	RSA5E-3,5-T	•	•	•	•	•	•	•	•	•	•	•																	
	RSA5E-5,0-T	•	•	•	•	•	•	•	•	•	•	•																	
	RSA5E-8,0-T	•	•	•	•	•	•	•	•	•	•	•																	
	RSA5E-10,0-T	•	•	•	•	•	•	•	•	•	•	•																	
	RSA5D-1,5-T																		•	•	•	•	•	•	•	•	•	•	
	RSA5D-3,5-T																		•	•	•	•	•	•	•	•	•	•	
	RSA5D-5-M																		•	•	•	•	•	•	•	•	•	•	
	RSA5D-8-M																		•	•	•	•	•	•	•	•	•	•	
	RSA5D-10-M																		•	•	•	•	•	•	•	•	•	•	
	RSA5D-12-M																		•	•	•	•	•	•	•	•	•	•	
<b>Frequency speed controllers</b>																													
	VFED-200-TA																			•	•	•	•	•	•	•	•	•	
	VFED-400-TA																			•	•	•	•	•	•	•	•	•	
	VFED-750-TA																			•	•	•	•	•	•	•	•	•	
	VFED-1100-TA																			•	•	•	•	•	•	•	•	•	
	VFED-1500-TA																			•	•	•	•	•	•	•	•	•	
<b>Temperature regulators</b>																													
	RTS-1-400																												
	RTSD-1-400																												
	RT-10	•	•	•	•	•	•	•	•	•	•	•																	
<b>Multi-speed fan switches</b>																													
	P2-5,0																												
	P3-5,0																												
	P5-5,0																												
	P2-1-300																												
	P3-1-300																												
<b>EC-motors controllers</b>																													
	R-1/010																												
<b>Sensors</b>																													
	T-1,5 N	•	•	•	•	•	•	•	•	•	•	•																	
	TH-1,5 N	•	•	•	•	•	•	•	•	•	•	•																	
	TF-1,5 N	•	•	•	•	•	•	•	•	•	•	•																	
	TP-1,5 N	•	•	•	•	•	•	•	•	•	•	•																	

- recommended
- suitable

		OV1 150 OVK1 150 VKOM 150	OV1 200 OVK1 200 VKOM 200	OV1 250 OVK1 250 VKOM 250	OV1 315 OVK1 315 VKOM 315
<b>Thyristor speed controllers</b>					
	RS-1-300	•	•	•	•
	RS-1-400	•	•	•	•
	RS-1 N (V)	•	•	•	•
	RS-1,5 N (V)	•	•	•	•
	RS-2 N (V)	•	•	•	•
	RS-2,5 N (V)	•	•	•	•
	RS-0,5-PS	•	•	•	•
	RS-1,5-PS	•	•	•	•
	RS-2,5-PS	•	•	•	•
	RS-4,0-PS	•	•	•	•
	RS-1,5-T	•	•	•	•
	RS-3,0-T			•	•
	RS-5,0-T				•
	RS-10,0-T				•
	RS-1,5-TA	•	•	•	•
	RS-3,0-TA			•	•
	RS-5,0-TA				•
	RS-10,0-TA				•
<b>Transformer speed controllers</b>					
	RSA5E-2-P	•	•	•	•
	RSA5E-2-M	•	•	•	•
	RSA5E-3-M	•	•	•	•
	RSA5E-4-M	•	•	•	•
	RSA5E-12-M	•	•	•	•
	RSA5E-1,5-T	•	•	•	•
	RSA5E-3,5-T	•	•	•	•
	RSA5E-5,0-T	•	•	•	•
	RSA5E-8,0-T	•	•	•	•
	RSA5E-10,0-T	•	•	•	•
	RSA5D-1,5-T				
	RSA5D-3,5-T				
	RSA5D-5-M				
	RSA5D-8-M				
	RSA5D-10-M				
	RSA5D-12-M				
<b>Frequency speed controllers</b>					
	VFED-200-TA				
	VFED-400-TA				
	VFED-750-TA				
	VFED-1100-TA				
	VFED-1500-TA				
<b>Temperature regulators</b>					
	RTS-1-400				
	RTSD-1-400				
	RT-10	•	•	•	•
<b>Multi-speed fan switches</b>					
	P2-5,0				
	P3-5,0				
	P5-5,0				
	P2-1-300				
	P3-1-300				
<b>EC-motors controllers</b>					
	R-1/010				
<b>Sensors</b>					
	T-1,5 N	•	•	•	•
	TH-1,5 N	•	•	•	•
	TF-1,5 N	•	•	•	•
	TP-1,5 N	•	•	•	•

• recommended

• suitable



# ROOF FANS

## ▶ VENTS VKV Series



- ▶ Centrifugal roof fans in the steel casing with vertical exhaust of air and the air capacity up to 4700 m<sup>3</sup>/h. Designed for exhaust ventilation systems.

## ▶ VENTS VKH Series



- ▶ Centrifugal roof fans in the steel casing with the horizontal exhaust of air and the air capacity up to 4700 m<sup>3</sup>/h. Designed for exhaust ventilation systems.

## ▶ VENTS VKMK (VKMKp) Series

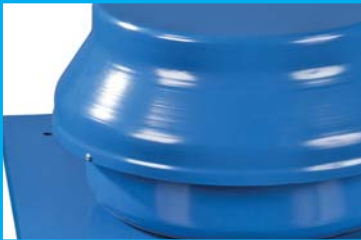

- ▶ Centrifugal roof fans in the steel casing with the horizontal exhaust of air and the air capacity up to 1880 m<sup>3</sup>/h. Designed for exhaust ventilation systems.

## ▶ VENTS VOK Series



- ▶ Axial roof fans in the steel casing with the horizontal exhaust of air and the air capacity up to 2500 m<sup>3</sup>/h.

## ▶ VENTS VOK1 Series



- ▶ Axial roof fans in the steel casing with the horizontal exhaust of air and the air capacity up to 1700 m<sup>3</sup>/h.

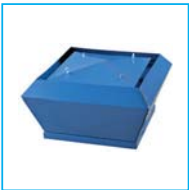

**VENTS VKV**  
**Centrifugal roof fan**

Air capacity – up to 4700 m<sup>3</sup>/h

page  
142

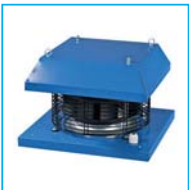

**VENTS VKH**  
**Centrifugal roof fan**

Air capacity – up to 4700 m<sup>3</sup>/h

page  
142

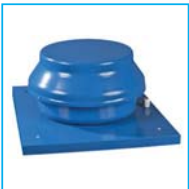

**VENTS VKMK (VKMKp)**  
**Centrifugal roof fan**

Air capacity – up to 1880 m<sup>3</sup>/h

page  
148

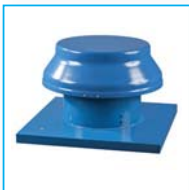

**VENTS VOK**  
**Axial roof fan**

Air capacity – up to 2500 m<sup>3</sup>/h

page  
150

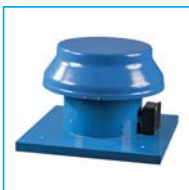

**VENTS VOK1**  
**Axial roof fan**

Air capacity – up to 1700 m<sup>3</sup>/h

page  
152

Fans Series  
**VENTS VKV**



Centrifugal roof fans with the air capacity up to **4700 m<sup>3</sup>/h** in the steel casing with the vertical exhaust of air

Fans Series  
**VENTS VKH**



Centrifugal roof fans with the air capacity up to **4700 m<sup>3</sup>/h** in the steel casing with the horizontal exhaust of air

■ **Applications**

Exhaust ventilation system for various premises suitable for roof mounting. Compatible with Ø 200 to 500 mm air ducts. Suitable for any roof types as well as vertical ventilation shafts.

■ **Design**

The fan casing is made of steel with polymeric coating.

■ **Motor**

The centrifugal impeller with backward-curved blades is mounted directly on the two-, four - or six-pole

single- or three-phase asynchronous motor shaft. The motor is equipped with thermal overheating protection with automatic restart as well as ball bearings for long service life. For precise features, safe operation and low noise, each turbine is dynamically balanced while assembly. Motor protection rating IP 44.

■ **Speed control**

Both smooth or step speed control is performed by means of the thyristor or autotransformer controller. Several fans can be connected to one controller in case the total power and operating current do not exceed the rated controller values.

■ **Mounting**

The fan is mounted on the roof directly above the ventilating duct or shaft and is firmly fixed to the flat surface by means of a connecting plate. While mounting VKH fans directly onto the flat roof a supporting block shall be provided to prevent water and snow drops into the vent of the ventilation shaft. Electrical connection and installation shall be performed in compliance with the manual and circuit diagram on the terminal box.

**Designation key:** \_\_\_\_\_

Series and modification	Number of poles	Phase	Turbine standard size
<b>VENTS VKV</b> – vertical air exhaust <b>VENTS VKH</b> – horizontal air exhaust	<b>2</b> – 2 poles; <b>4</b> – 4 poles; <b>6</b> – 6 poles	<b>E</b> – single-phase modification <b>D</b> – three-phase modification	220; 225; 250; 280; 310; 355; 400; 450; 500

**Accessories**



page 240    page 240    page 294    page 296    page 310    page 2310    page 311    page 314    page 315

**Fan overall dimensions:**

Type	Dimensions [mm]						Mass [kg]
	∅D	∅d	H	L	L1	L2	
VKH 2E 220	245	10	228	338	245	338	6,9
VKH 2E 225	210	10	228	338	245	338	7,1
VKH 2E 250	286	10	265	400	330	365	10,1
VKH 2E 280	286	10	265	400	330	365	10,2
VKH 4E 310	286	10	300	438	330	400	10,2
VKH 4D 310	286	10	300	438	330	400	10,2
VKH 4E 355	438	12	348	598	450	550	15,6
VKH 4D 355	438	12	325	598	450	550	15,6
VKH 4E 400	438	12	348	598	450	550	21,0
VKH 4E 450	438	12	400	668	450	640	22,7
VKH 4D 400	438	12	348	598	450	550	22,0
VKH 4D 450	438	12	400	668	450	640	22,7
VKH 6E 500	438	12	465	668	450	640	26,6

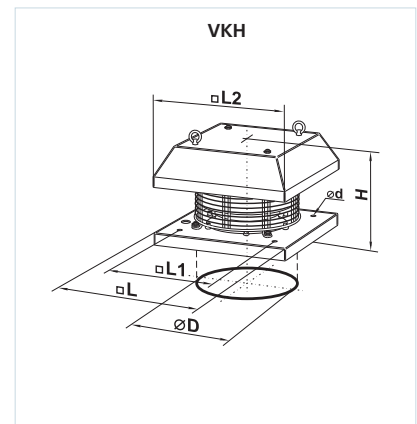

**Fan overall dimensions:**

Type	Dimensions [mm]					Mass [kg]
	∅D	H	L2	L1	L	
VKV 2E 220	245	275	460	245	338	8,9
VKV 2E 225	210	275	460	245	338	9,6
VKV 2E 250	286	275	520	330	400	12,0
VKV 2E 280	286	275	520	330	400	12,7
VKV 4E 310	286	330	560	330	438	17,8
VKV 4D 310	286	330	560	330	438	17,8
VKV 4E 355	438	420	783	450	598	22,0
VKV 4D 355	438	420	783	450	598	22,0
VKV 4E 400	438	420	783	450	598	27,5
VKV 4E 450	438	454	872	450	668	30,0
VKV 4D 400	438	420	783	450	598	27,5
VKV 4D 450	438	454	872	450	668	30,0
VKV 6E 500	438	454	872	450	668	33,8

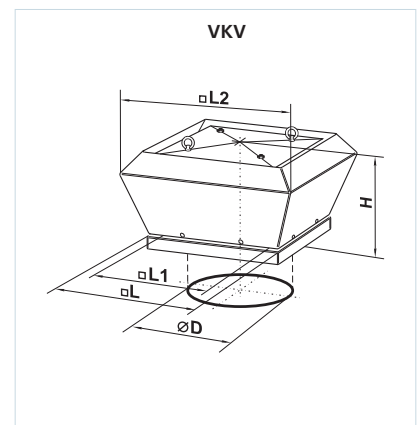

VENTS  
VKV / VKH  
FAN SERIES

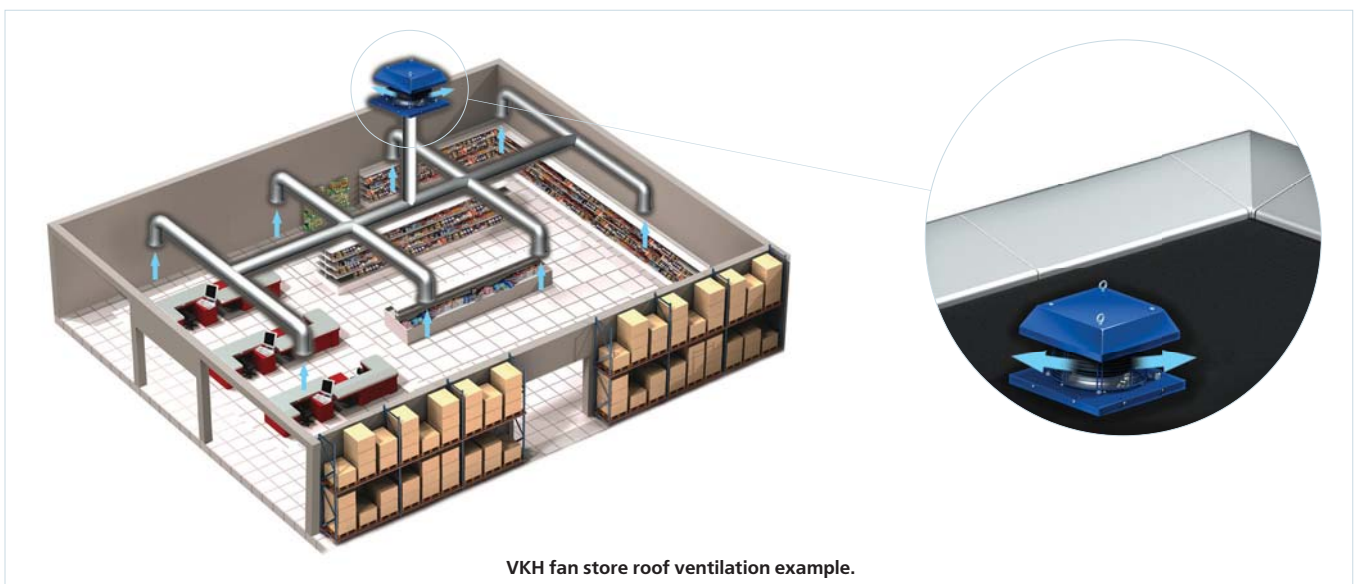

VKH fan store roof ventilation example.

## CENTRIFUGAL ROOF FANS

### Technical data:

	<b>VKV / VKH 2E 220</b>	<b>VKV / VKH 2E 225</b>	<b>VKV / VKH 2E 250</b>	<b>VKV / VKH 2E 280</b>
Voltage [V / 50 Hz]	230	230	230	230
Power [W]	85	135	155	225
Current [A]	0,38	0,6	0,7	1,0
Maximum air flow [m <sup>3</sup> /h]	700	900	1300	1780
RPM [min <sup>-1</sup> ]	2700	2650	2600	2700
Noise level at 3 m [dBA]	49	49	65	66
Maximum operating temperature [°C]	55	55	50	50
Protection rating	IP X4	IP X4	IP X4	IP X4

### Technical data:

	<b>VKV / VKH 4E 310</b>	<b>VKV / VKH 4D 310</b>	<b>VKV / VKH 4E 355</b>	<b>VKV / VKH 4D 355</b>
Voltage [V / 50 Hz]	230	400	230	400
Power [W]	120	110	245	170
Current [A]	0,54	0,32	1,12	0,52
Maximum air flow [m <sup>3</sup> /h]	1820	1950	2800	2350
RPM [min <sup>-1</sup> ]	1370	1400	1420	1400
Noise level at 3 m [dBA]	45	53	46	53
Maximum operating temperature [°C]	85	65	50	70
Protection rating	IP X4	IP X4	IP X4	IP X4

### Technical data:

	<b>VKV / VKH 4E 400</b>	<b>VKV / VKH 4D 400</b>	<b>VKV / VKH 4E 450</b>	<b>VKV / VKH 4D 450</b>	<b>VKV / VKH 6E 500</b>
Voltage [V / 50 Hz]	230	400 Y	230	400 Y	230
Power [W]	480	385	640	470	385
Current [A]	2,4	0,7	3,1	0,82	1,82
Maximum air flow [m <sup>3</sup> /h]	3400	3800	3850	4300	4700
RPM [min <sup>-1</sup> ]	1400	1430	1350	1430	880
Noise level at 3 m [dBA]	52	52	53	53	47
Maximum operating temperature [°C]	80	60	50	50	50
Protection rating	IP X4	IP X4	IP X4	IP X4	IP X4



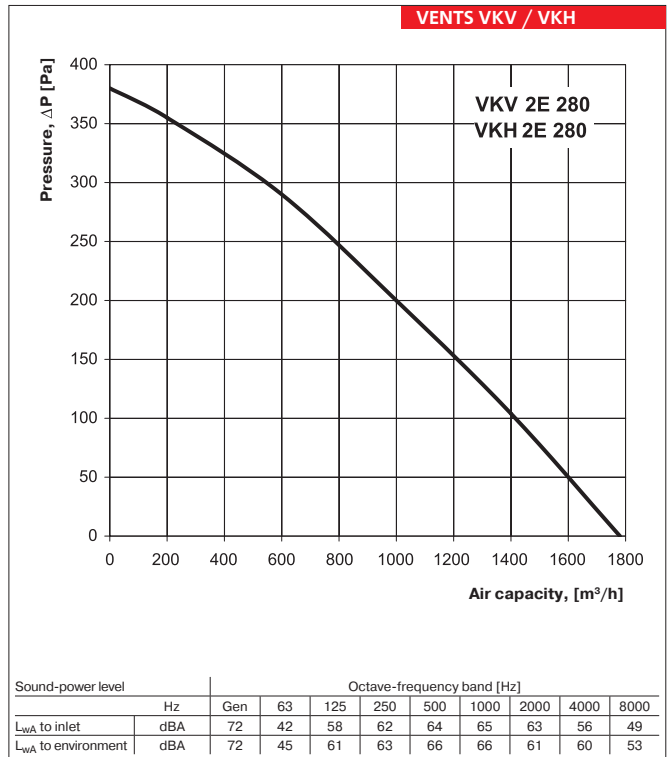
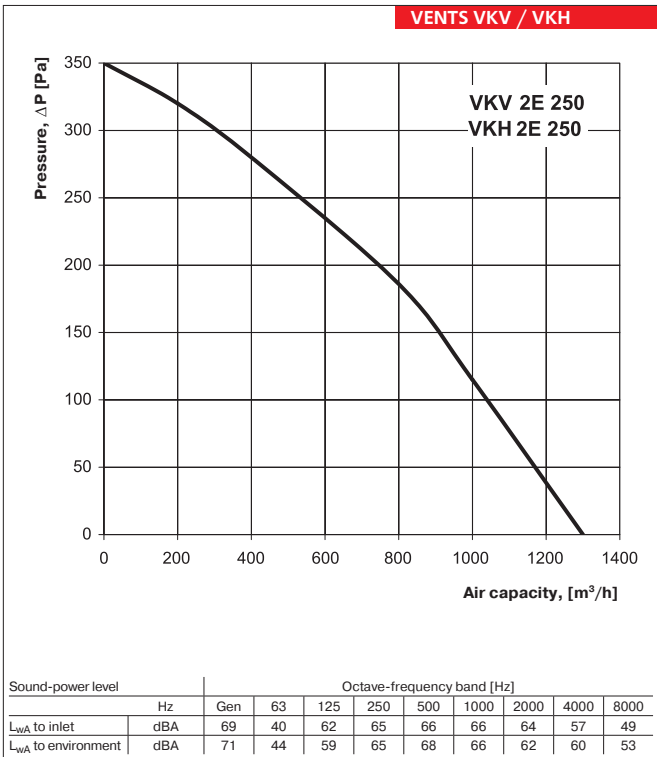
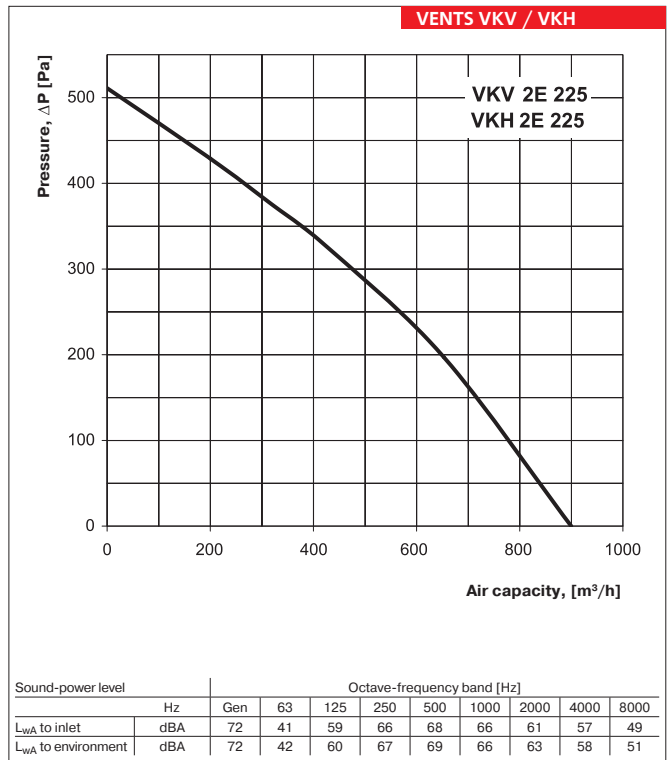
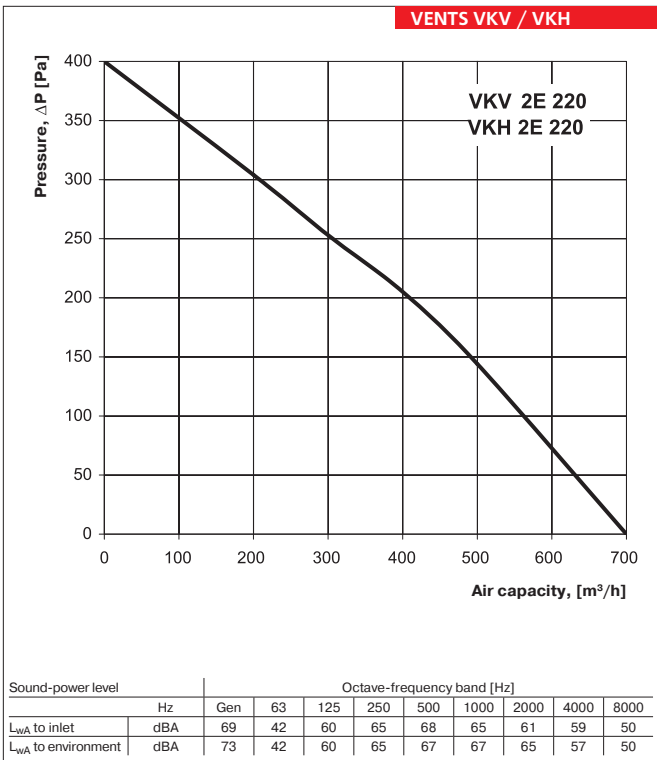

VENTS  
VKV / VKH  
FAN SERIES



VENTS VKV / VKH

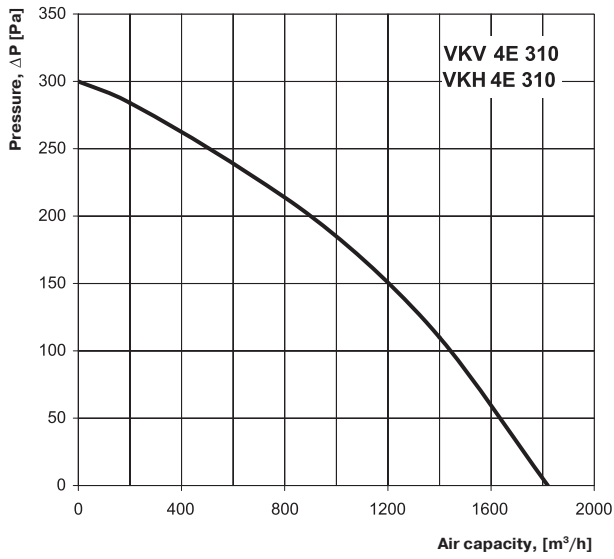

Sound-power level		Octave-frequency band [Hz]								
	Hz	Gen	63	125	250	500	1000	2000	4000	8000
$L_{WA}$ to inlet	dBA	57	44	45	50	53	52	51	43	36
$L_{WA}$ to environment	dBA	60	47	50	53	56	57	51	45	39

VENTS VKV / VKH

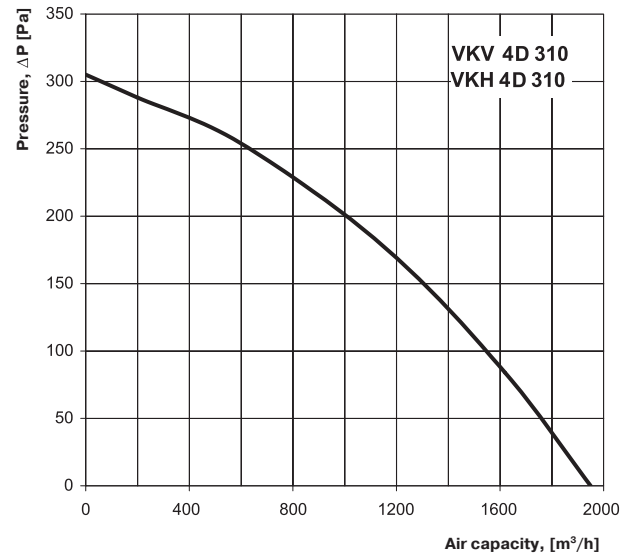

Sound-power level		Octave-frequency band [Hz]								
	Hz	Gen	63	125	250	500	1000	2000	4000	8000
$L_{WA}$ to inlet	dBA	58	45	46	51	55	53	49	45	37
$L_{WA}$ to environment	dBA	60	48	51	52	54	56	49	44	38

VENTS VKV / VKH

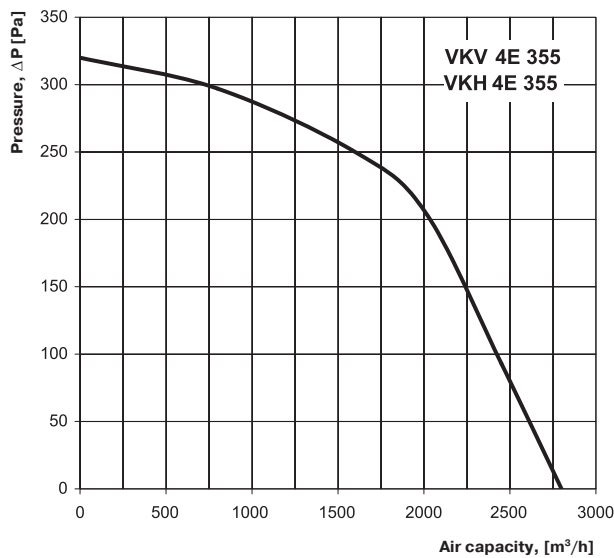

Sound-power level		Octave-frequency band [Hz]								
	Hz	Gen	63	125	250	500	1000	2000	4000	8000
$L_{WA}$ to inlet	dBA	69	53	58	61	62	63	59	54	45
$L_{WA}$ to environment	dBA	72	57	60	63	65	64	61	55	49

VENTS VKV / VKH

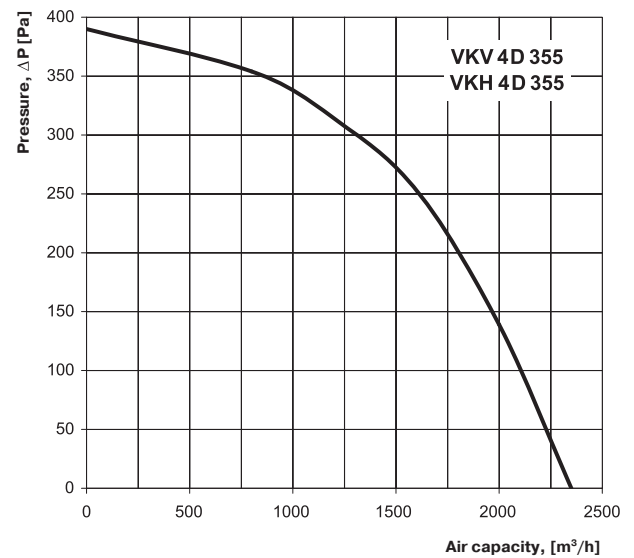

Sound-power level		Octave-frequency band [Hz]								
	Hz	Gen	63	125	250	500	1000	2000	4000	8000
$L_{WA}$ to inlet	dBA	67	56	57	63	65	64	59	54	47
$L_{WA}$ to environment	dBA	72	56	60	62	66	62	63	55	49

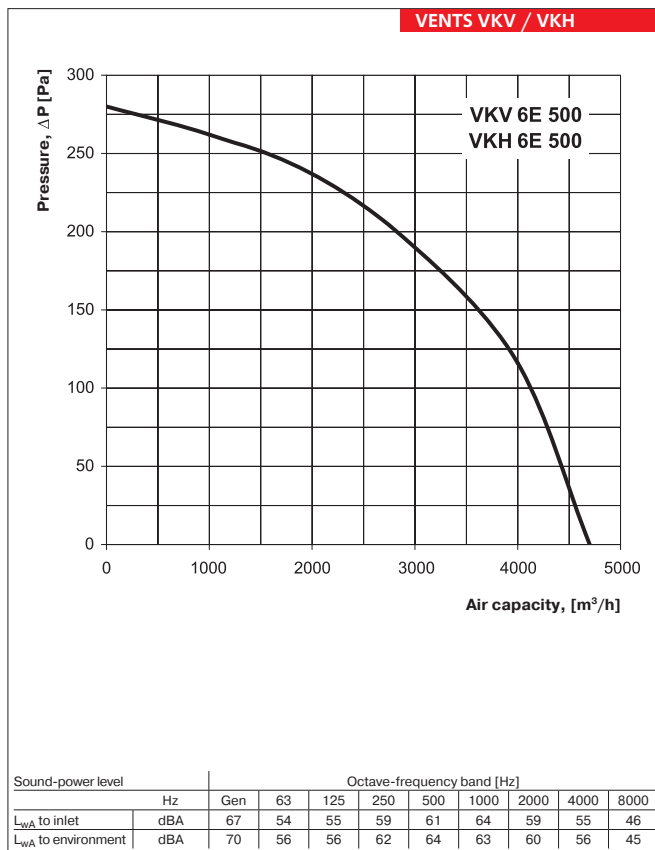
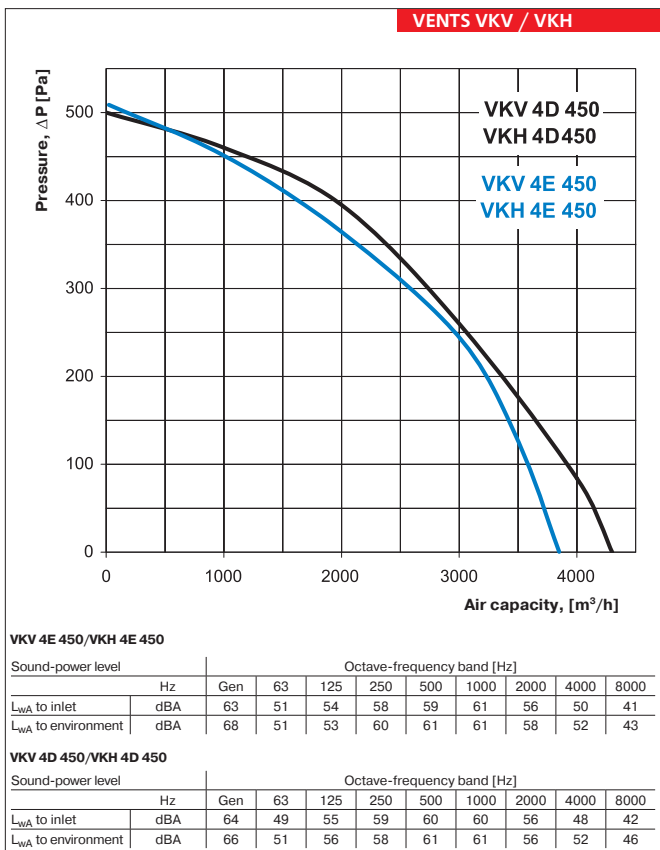
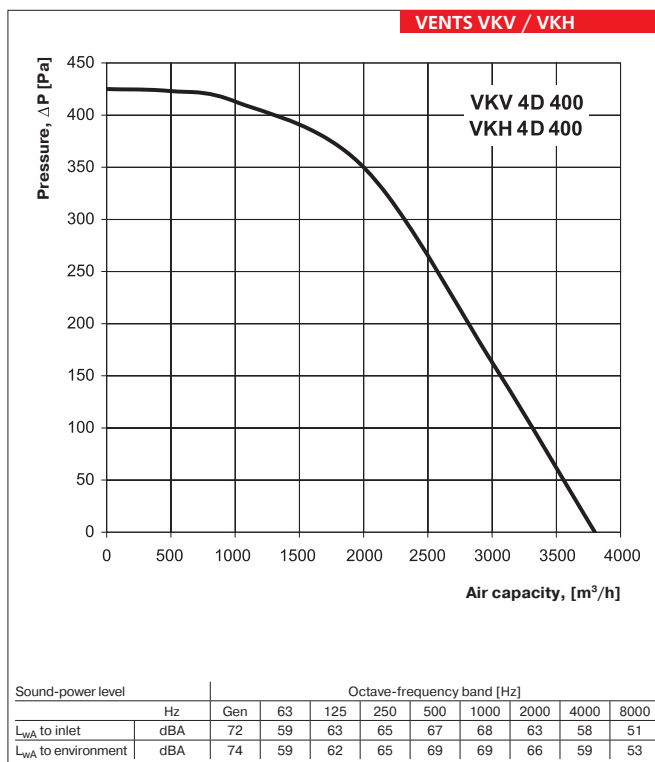
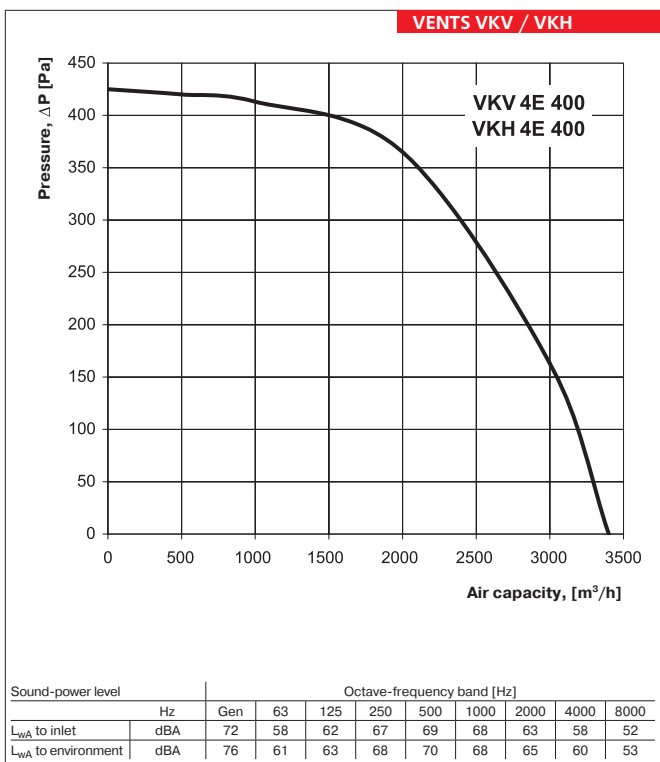

VENTS  
VKV / VKH  
FAN SERIES

Series  
**VENTS VKMK**



Centrifugal roof fans with the air capacity up to **1880 m<sup>3</sup>/h** in the steel casing with the horizontal exhaust of air

■ **Applications**

Exhaust ventilation system for various premises. Suitable for mounting on any roof types as well as connection to Ø 150 up to 315 mm round air ducts.

■ **Design**

The fan casing is made of steel with polymeric coating. A thin steel connection plate is provided at the bottom of VKMKp model.

■ **Motor**

The centrifugal impeller with backward curved blades is powered by means of the single-phase motor with external rotor. The motors are equipped with thermal overheating protection with automatic restart as well as ball bearings for long service life. For precise features, safe operation and low noise of the fan, each turbine is dynamically balanced while assembly. Motor protection rating IP 44.

■ **Speed control**

Smooth or step speed control is performed by means of the thyristor or autotransformer controller. Several fans can be connected to one controller in case the total power and operating current do not exceed the rated controller values.

■ **Mounting**

The fan is mounted on the roof directly above the ventilating duct or shaft and is firmly fixed to the flat surface by means of a connecting plate. Electrical connection and mounting shall be performed in compliance with the manual and wiring diagram on the terminal box.

**Technical data:**

	VKMK 150	VKMK 200	VKMK 250	VKMK 315
Voltage [V / 50 Hz]	230	230	230	230
Power [W]	98	154	194	296
Current [A]	0,43	0,67	0,85	1,34
Maximum air flow [m <sup>3</sup> /h]	555	950	1310	1880
RPM [min <sup>-1</sup> ]	2705	2375	2790	2720
Noise level at 3 m [dBA]	47	48	52	54
Maximum operating temperature [°C]	-25 +55	-25 +50	-25 +50	-25 +45
Protection rating	IP X4	IP X4	IP X4	IP X4

**Fan overall dimensions:**

Type	Dimensions [mm]					Mass [kg]
	ØD	ØD1	H	L	L1	
VKMK 150	149	400	230	440	330	7,2
VKMK 200	198	400	250	440	330	8,1
VKMK 250	248	400	249	590	450	10,1
VKMK 315	315	500	269	590	450	10,1
VKMKp 150	149	400	230	440	330	8,2
VKMKp 200	198	400	250	440	330	9,3
VKMKp 250	248	400	249	590	450	12,3
VKMKp 315	315	500	269	590	450	12,2

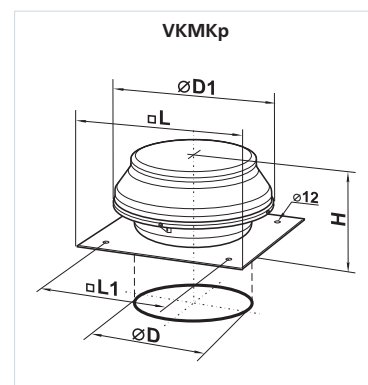
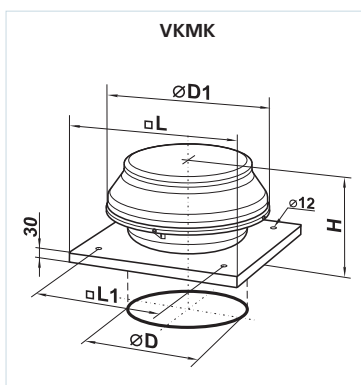

**Designation key:**

Series		Flange diameter, mm
<b>VENTS VKMK</b>	<b>p</b> – with a flat connection plate	150; 200; 250; 315

**Accessories**



page 240   page 240   page 294   page 296   page 310   page 310   page 311   page 314   page 315

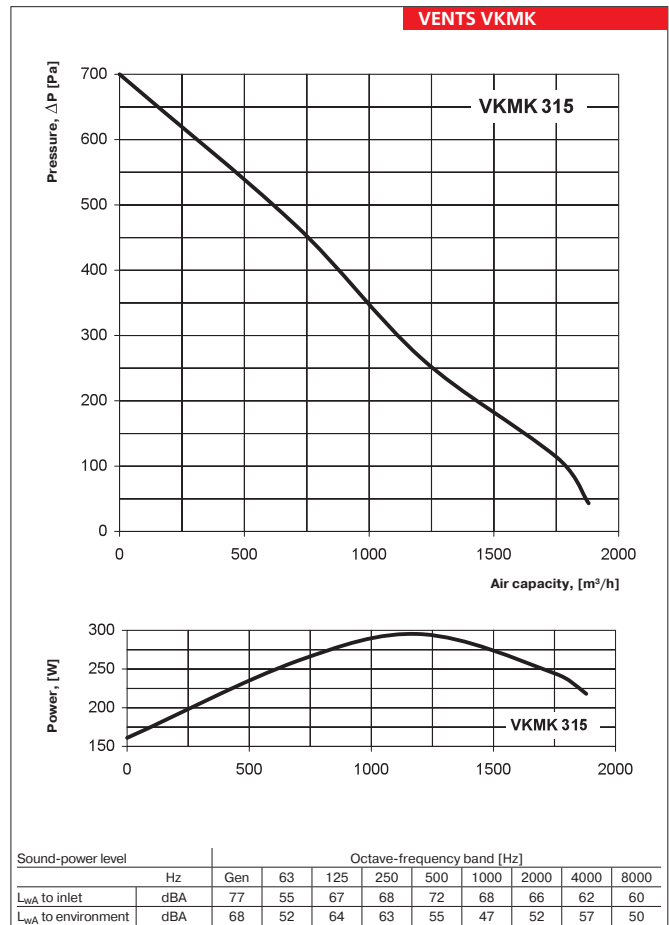
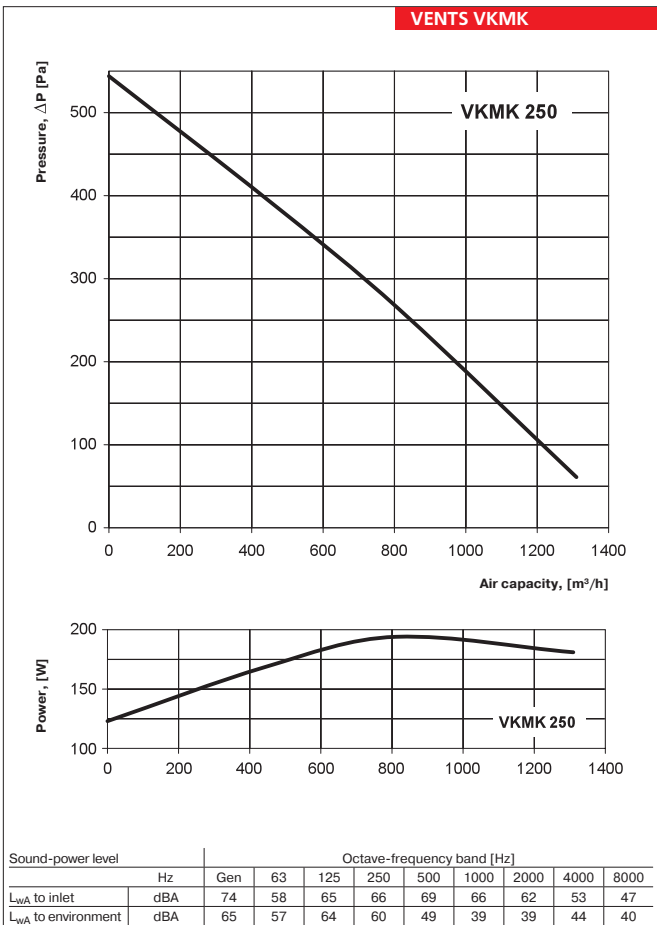
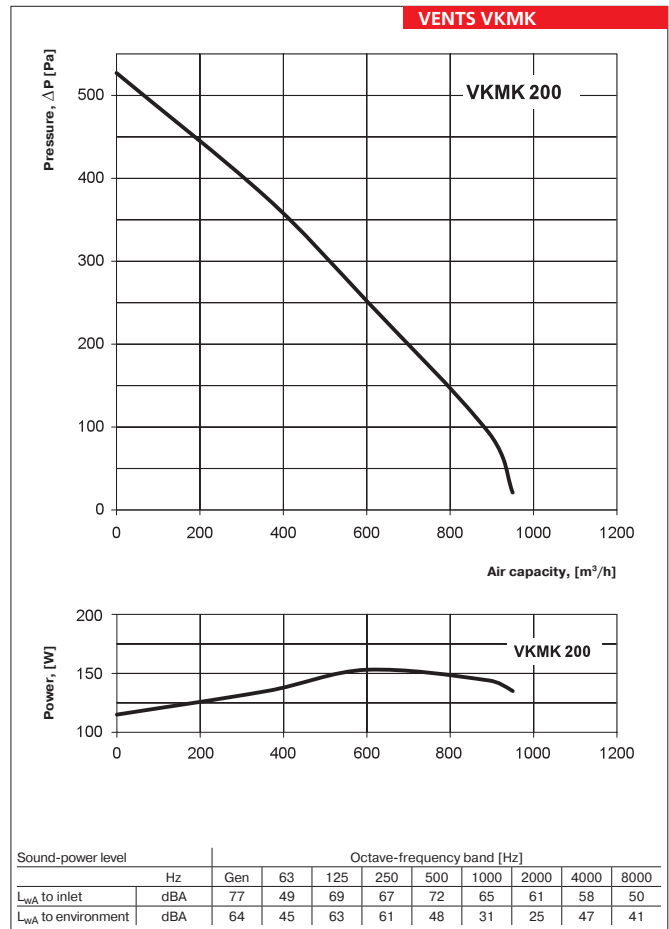
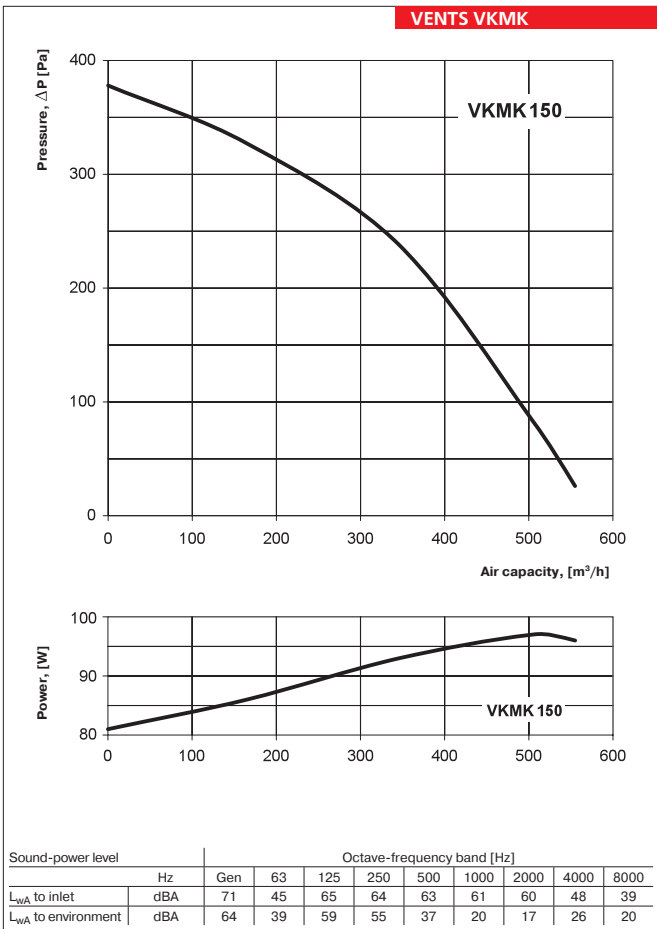

VENTS VKMK  
FAN SERIES

Series  
**VENTS VOK**

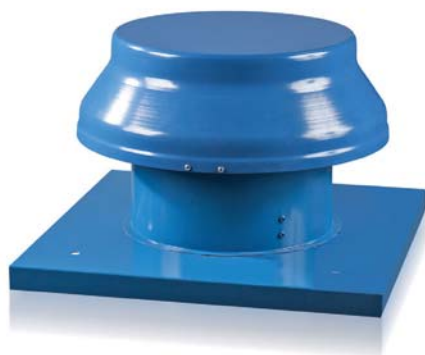

Axial roof fans with the air capacity up to **2500 m<sup>3</sup>/h** in the steel casing with the horizontal exhaust of air.

■ **Applications**

Exhaust ventilation system for various premises for roof mounting. Compatible with Ø 200 to 500 mm round air ducts.

■ **Design**

The fan casing is made of steel with polymeric coating.

■ **Motor**

The impellers are powered with two- or four-pole, single- or three-phase asynchronous motors with external rotor and built-in thermal overheating protection with automatic restart depending on the model. Ball bearings in the motor ensure long service life. Motor protection rating IP 44.

■ **Speed control**

Both smooth or step speed control is performed by means of the thyristor or autotransformer controller. Several fans can be connected to one controller under condition that the total power and operating current do not exceed the rated controller values.

■ **Mounting**

The fan is mounted on the roof directly above the ventilating duct or shaft and is firmly fixed to the flat surface by means of a connecting plate. While mounting VOK fans directly onto the flat roof a supporting block shall be provided to prevent water and snow drops into the vent of the ventilation shaft. Electrical connection and installation shall be performed in compliance with the manual and circuit diagram on the terminal box.

**Technical data:**

	VOK 2E 200	VOK 2E 250	VOK 4E 250	VOK 2E 300	VOK 4E 300	VOK 4E 350
Voltage [V / 50 Hz]	230	230	230	230	230	230
Power [W]	55	80	50	145	75	140
Current [A]	0,26	0,4	0,22	0,66	0,35	0,65
Maximum air flow [m <sup>3</sup> /h]	860	1050	800	2230	1340	2500
RPM [min <sup>-1</sup> ]	2300	2400	1380	2300	1350	1380
Noise level at 3 m [dBA]	50	60	55	60	58	62
Maximum operating temperature [°C]	-30 +60	-30 +60	-30 +60	-30 +60	-30 +60	-30 +60
Protection rating	IP 54	IP 54	IP 54	IP 54	IP 54	IP 54

**Fan overall dimensions:**

Type	Dimensions [mm]					Mass [kg]
	ØD	ØD1	H	L	L1	
VOK 2E 200	207	341	220	410	245	4,3
VOK 2E 250	262	401	250	460	330	6,5
VOK 4E 250	262	401	250	460	330	6,5
VOK 2E 300	312	401	260	560	450	8,7
VOK 4E 300	312	401	260	560	450	8,7
VOK 4E 350	362	500	260	630	535	10,9

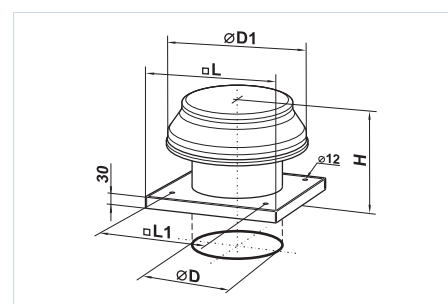

**Designation key:**

Series	Motor modification		Impeller diameter
VENTS VOK	Number of poles	Phase	200; 250; 300; 350
	2 4	E – single phase	

**Accessories**



page 240    page 240    page 294    page 296    page 310    page 310    page 311    page 314    page 315



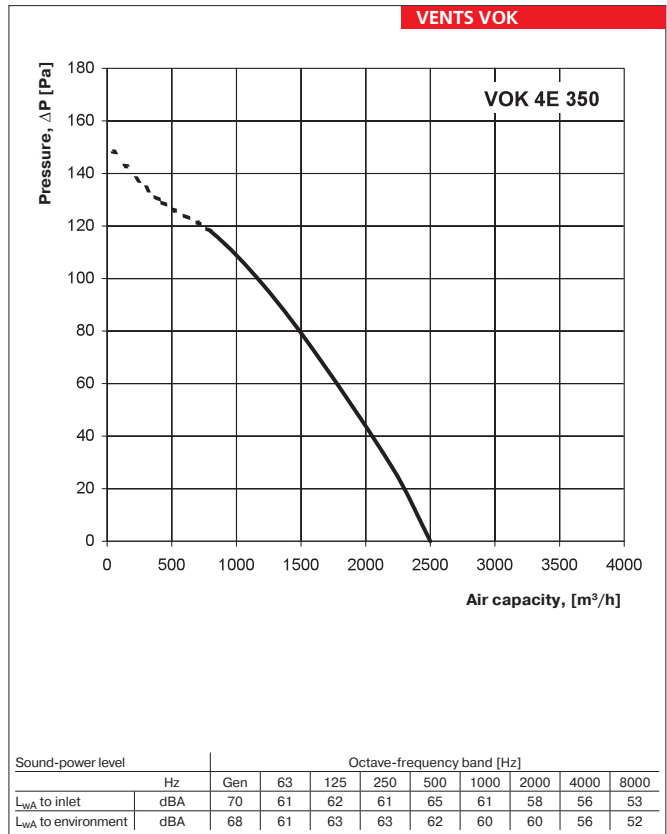
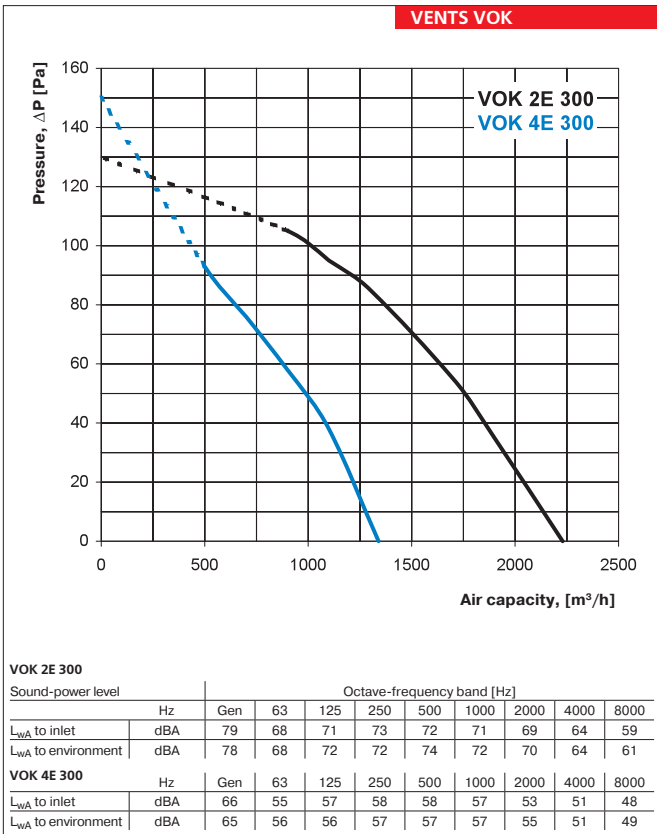
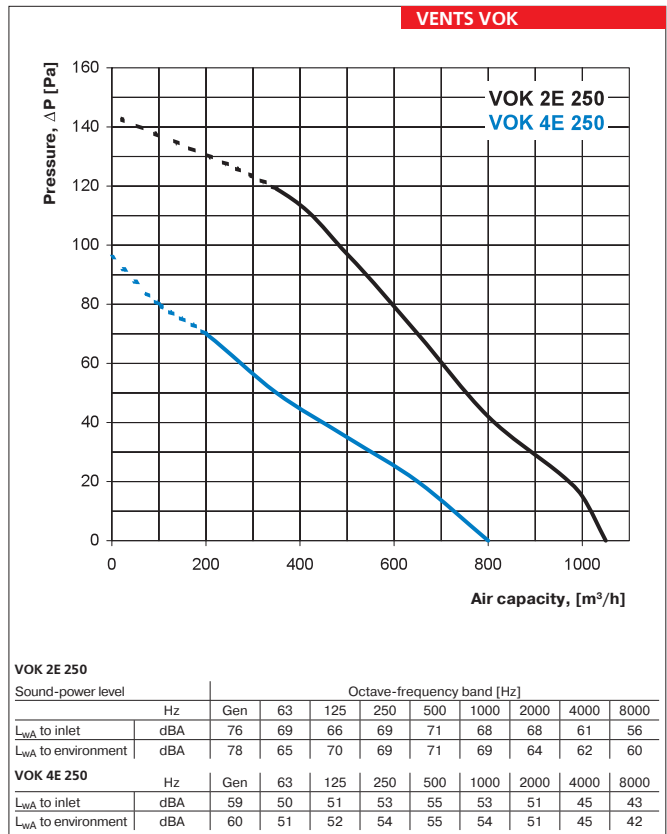
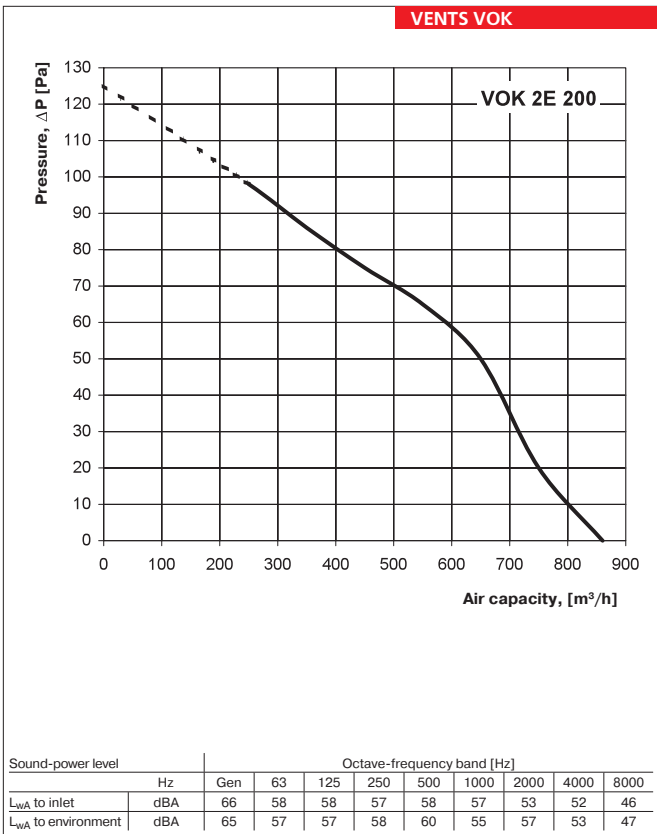

FAN SERIES VENTS VOK

Series  
**VENTS VOK1**

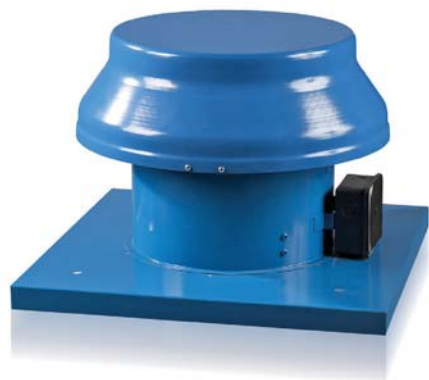

Axial roof fans with the air capacity up to **1700 m<sup>3</sup>/h** in the steel casing with the horizontal exhaust of air.

■ **Applications**

Exhaust ventilation system for various premises suitable for roof mounting. Compatible with Ø 200 to 315 mm round air ducts.

■ **Design**

The fan casing is made of steel with polymeric coating, impeller is made of aluminium.

■ **Motor**

Single-phase asynchronous motor with external rotor and built-in thermal protection with automatic restart. Ball bearings ensure long service life. Motor protection rating IP 44.

■ **Speed control**

Both smooth or step speed control is performed by means of the thyristor or autotransformer controller. Several fans can be connected to one controller under condition that the total power and operating current do not exceed the rated controller values.

■ **Mounting**

The fan is mounted on the roof directly above the ventilating duct or shaft and is firmly fixed to the flat surface by means of a connecting plate. While mounting VOK1 fans directly onto the flat roof a supporting block shall be provided to prevent water and snow drops into the vent of the ventilation shaft. Electrical connection and installation shall be performed in compliance with the manual and wiring diagram on the terminal box.

**Technical data:**

	VOK1 200	VOK1 250	VOK1 315
Voltage [V / 50 Hz]	230	230	230
Power [W]	43	68	110
Current [A]	0,28	0,48	0,75
Maximum air flow [m <sup>3</sup> /h]	405	1070	1700
RPM [min <sup>-1</sup> ]	1300	1300	1300
Noise level at 3 m [dBA]	32	48	54
Maximum operating temperature [°C]	50	50	50
Protection rating	IP X4	IP X4	IP X4

**Fan overall dimensions:**

Type	Dimensions [mm]					Mass [kg]
	ØD	ØD1	H	L	L1	
VOK1 200	207	341	220	410	245	4,9
VOK1 250	262	401	250	460	330	6,8
VOK1 315	312	500	260	560	450	9,2

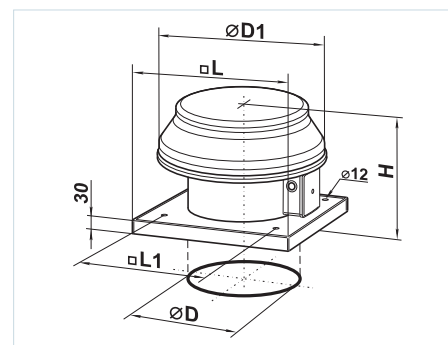

**Designation key:**

Series <b>VENTS VOK1</b>	Impeller diameter 200; 250; 315
-----------------------------	------------------------------------

**Accessories**



page 240    page 240    page 294    page 296    page 310    page 310    page 311    page 314    page 315

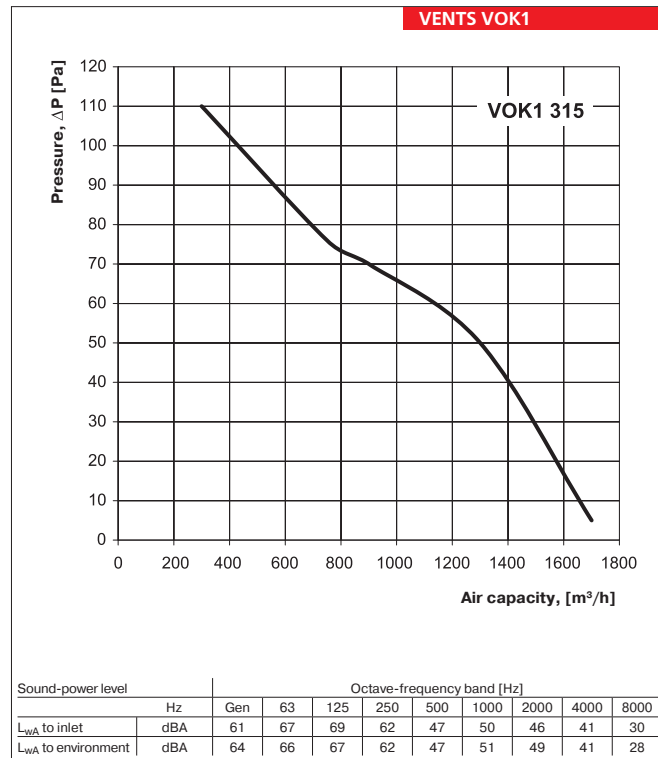
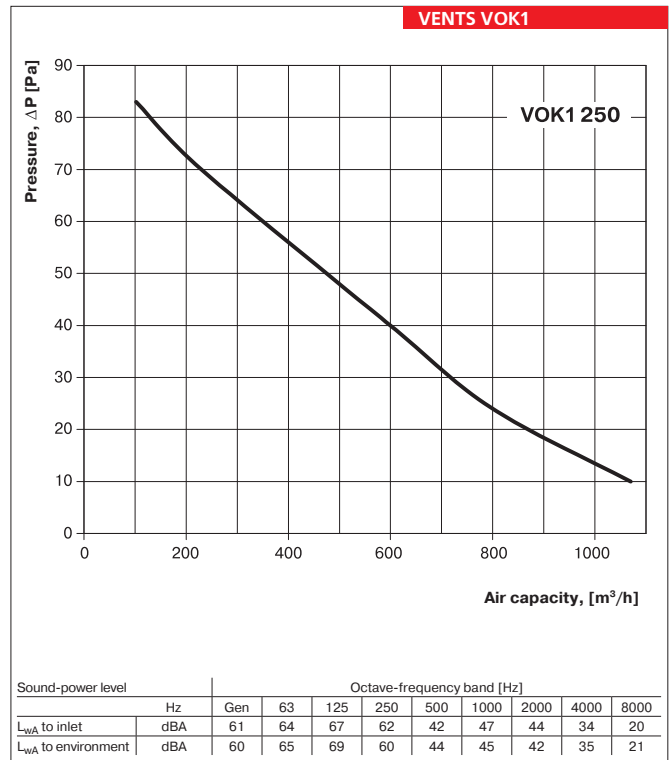
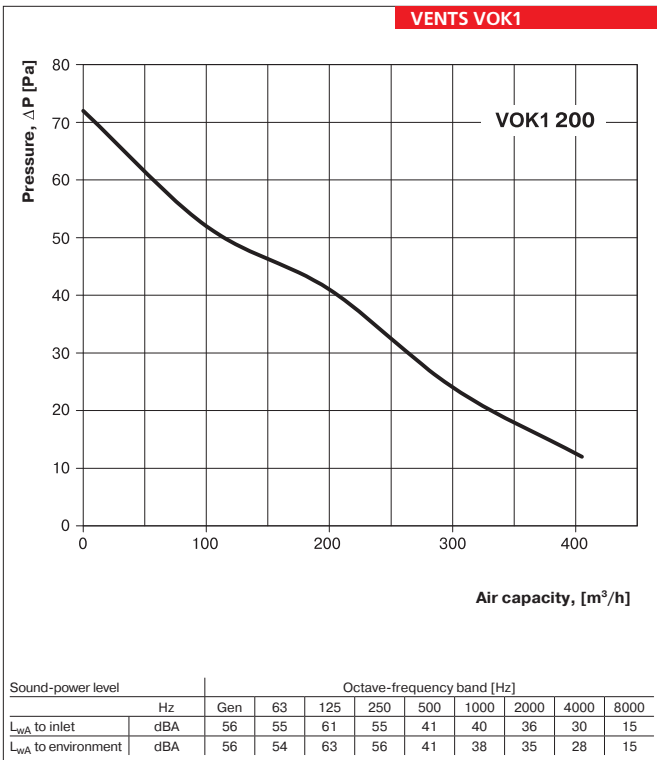

FAN SERIES VENTS VOK1





# SUPPLY UNITS

# EXHAUST UNITS

## ▶ VENTS VPA Series



▶ Sound- and heat-insulated fan units with the air capacity up to 1520 m<sup>3</sup>/h are designed to supply fresh filtered air to premises. For operation of the units during low outside temperatures electrical heating coils are installed. Compatible with Ø 100, 125, 150, 200, 250, 315 mm round air ducts.

## ▶ VENTS MPA...E Series



▶ Sound- and heat-insulated fan units with the air capacity up to 3500 m<sup>3</sup>/h are designed to provide fresh filtered air to premises. For operation of the units during low outside temperatures the electrical heating coils are installed. Compatible with 400x200, 500x250, 500x300, 600x300, 600x350 mm rectangular air ducts.

## ▶ VENTS MPA...W Series



▶ Sound- and heat-insulated fan units with the air capacity up to 6500 m<sup>3</sup>/h are designed to provide fresh filtered air to premises. For operation of the units during low outside temperatures water heating coils are installed. Compatible with 400x200, 500x250, 500x300, 600x300, 600x350 and 800x500 mm rectangular air ducts.

## ▶ VENTS VUT PA... E Series



▶ Compact suspended sound-insulated fan units with the air capacity up to 3350 m<sup>3</sup>/h are designed to provide fresh filtered air to premises. For operation of the units during low outside temperatures electrical heating coils are installed. Compatible with 400x200, 500x300, 600x350 mm rectangular air ducts.

## ▶ VENTS PA...W Series



▶ Compact suspended sound-insulated fan units with the air capacity up to 4100 m<sup>3</sup>/h are designed to provide fresh filtered air to premises. For operation of the units during low outside temperatures water heating coils are installed. Compatible with 400x200, 500x300, 600x350, 700x400 mm rectangular air ducts.

## ▶ VENTS VA Series



▶ Compact suspended sound-insulated fan units with the air capacity up to 4450 m<sup>3</sup>/h are designed to provide exhaust air removal from premises. Compatible with 400x200, 500x300, 600x350, 600x350, 700x400 mm rectangular air ducts.





**VENTS VPA series supply units**

Air capacity up to 1520 m<sup>3</sup>/h

page  
158



**VENTS MPA...E series supply units**

Air capacity up to 3500 m<sup>3</sup>/h

page  
162

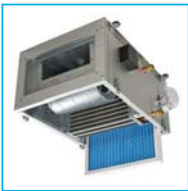

**VENTS MPA...W series supply units**

Air capacity up to 6500 m<sup>3</sup>/h

page  
162



**VENTS PA...E series supply units**

Air capacity up to 3350 m<sup>3</sup>/h

page  
172



**VENTS PA...W series supply units of**

Air capacity up to 4100 m<sup>3</sup>/h

page  
172



**VENTS VA series exhaust units**

Air capacity up to 4450 m<sup>3</sup>/h

page  
180

Series  
**VENTS VPA**



LCD control panel

Supply units with the air capacity up to **1520 m<sup>3</sup>/h** in the compact sound- and heat-insulated casing with electric heating battery.

■ **Description**

The fan unit provides filtration, heating and supply of fresh air to premises with the air capacity from 200 up to 1500 m<sup>3</sup>/h. All the models are compatible with 100, 125, 150, 200, 250, 315 mm round air ducts.

■ **Casing**

The casing is made of aluzink with internal heat- and sound-insulating 25 mm layer of mineral wool.

■ **Filter**

G4 filter ensures high degree of supply air purification.

■ **Heater**

Electric heating battery is designed for supply air heating during winter and off-season time.

■ **Fan**

Centrifugal fan with backward-curved blades and built-in thermal overheating protection with automatic restart. High-powered motor modification (VPA-1) is available for some standard sizes. The fan motor and impeller are dynamically balanced in two planes. The motor ball bearings are maintenance-free and are designed for at least 40 000 hours service life.

■ **Control and automation**

The supply unit is available in two modifications:

1. No control. Customer-defined and customer-selected automation system.
2. Integrated control and automation system to ensure control of air capacity, setting temperature of supply air, filter clogging degree etc. In addition the automation system provides overheating protection of heating elements. The remote unit control is effected by means of the external control unit with 10 m wire supplied as a standard.

■ **Control and protection functions**

- ▶ remote switching the unit on and off
- ▶ setting of required supply air temperature and maintaining selected temperature mode by means of the control panel (electric air heater control by means of the optosymistor)
- ▶ fan speed control by means of the control panel (3 speed modes)
- ▶ working-out of the required patterns during the unit switching on and off
- ▶ the unit daily or week timer operation
- ▶ active overheating protection of heating elements
- ▶ disabling electric air heating battery operation when the motor is not running
- ▶ electric heater overheating protection by means of two thermostats
- ▶ filter clogging control though the differential pressure sensor

■ **Mounting**

Air supply unit can be mounted on the floor, attached to a ceiling with a seat angle with anti-vibration mounts or attached to a wall by means of the brackets. The unit can be mounted either in service spaces (balcony, storage room, underground floor, roof space etc.) or in the main space by placing the unit above the suspended ceiling or in the pocket. The unit can be mounted in any position except for the vertical one with vertical air downstream because tubular heating elements are not allowed under the fan. Free access to the unit shall be provided for maintenance and filter cleaning.

**Designation key:** \_\_\_\_\_

Series		Flange diameter, mm	Electric heater power [kW]	Phase
<b>VENTS VPA</b>	1 - high-powered motor	100; 125; 150; 200; 250; 315	1,8; 2,4; 3,4; 3,6; 5,1; 6; 9	1 – single phase; 3 – three phases

**Accessories**



page 240    page 240    page 294    page 295    page 296    page 305

**Offered options to the units**



page 161

**Technical data:**

	VPA 100- 1,8-1	VPA 125- 2,4-1	VPA 150- 2,4-1	VPA 150- 3,4-1	VPA 150- 5,1-3	VPA 150- 6,0-3	VPA 200- 3,4-1	VPA 200- 5,1-3	VPA 200- 6,0-3
Unit supply voltage [V / 50 Hz]	1~ 230		1~ 230		3~ 400		1~ 230		3~ 400
Maximum fan power [W]	73	75	98			193			
Fan current [A]	0,32	0,33	0,43			0,84			
Electric heater capacity [kW]	1,8	2,4	2,4	3,4	5,1	6,0	3,4	5,1	6,0
Electric heater current [A]	7,8	10,4	10,4	14,8	7,4	8,7	14,8	7,4	8,7
Number of electrical heating elements	3	3	2	2	3	3	2	3	3
Total power of the unit [kW]	1,873	2,475	2,498	3,498	5,198	6,098	3,593	5,293	6,193
Total current of the unit [A]	8,12	10,73	10,83	15,23	7,83	9,13	15,64	8,24	9,54
Air capacity [m <sup>3</sup> /h]	190	285	425			810			
RPM	2830	2800	2705			2780			
Noise level at 3m [dB[A]]	27	28	29			30			
Operating temperature [°C]	-25 up to +55		-25 up to +55			-25 up to +45			
Casing material	aluzink		aluzink			aluzink			
Insulation	25 mm mineral wool		25 mm mineral wool			25 mm mineral wool			
Filter	G4		G4			G4			
Connected air duct size [mm]	100	125	150			200			
Weight, [kg]	50		50			52			

**Technical data:**

	VPA 250- 3,6-3	VPA 250- 6,0-3	VPA 250- 9,0-3	VPA 315- 6,0-3	VPA 315- 9,0-3	VPA-1 315- 6,0-3	VPA-1 315- 9,0-3
Unit supply voltage [V / 50 Hz]	3~ 400			3~ 400			
Maximum fan power [W]	194			171		296	
Fan current [A]	0,85			0,77		1,34	
Electric heater capacity [kW]	3,6	6,0	9,0	6,0	9,0	6,0	9,0
Electric heater current [A]	5,3	8,7	13,0	8,7	13,0	8,7	13,0
Number of electrical heating elements	3	3	3	3	3	3	3
Total power of the unit [kW]	3,794	6,194	9,194	6,171	9,171	6,296	9,296
Total current of the unit [A]	6,15	9,55	13,85	9,47	13,77	10,04	14,34
Air capacity [m <sup>3</sup> /h]	990			1190		1520	
RPM	2790			2600		2720	
Noise level at 3m [dB[A]]	30			30		30	
Operating temperature [°C]	-25 up to +50			-25 up to +50		-25 up to +45	
Casing material	aluzink			aluzink			
Insulation	25 mm mineral wool			25 mm mineral wool			
Filter	G4			G4			
Connected air duct size [mm]	250			315			
Weight, [kg]	52			62			

**Unit overall dimensions:**

Type	Dimensions, [mm]					
	∅D	B	B1	H	L	L1
VPA 100	99	382	421,5	408	800	647
VPA 125	124	382	421,5	408	800	647
VPA 150	149	455	496,5	438	800	647
VPA 200	199	487	526,5	513	835	684
VPA 250	249	487	526,5	513	835	684
VPA 315	314	527	566,5	548	900	750

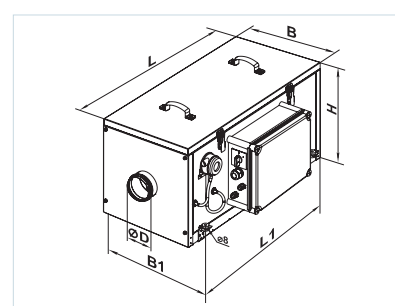

VENTS VPA

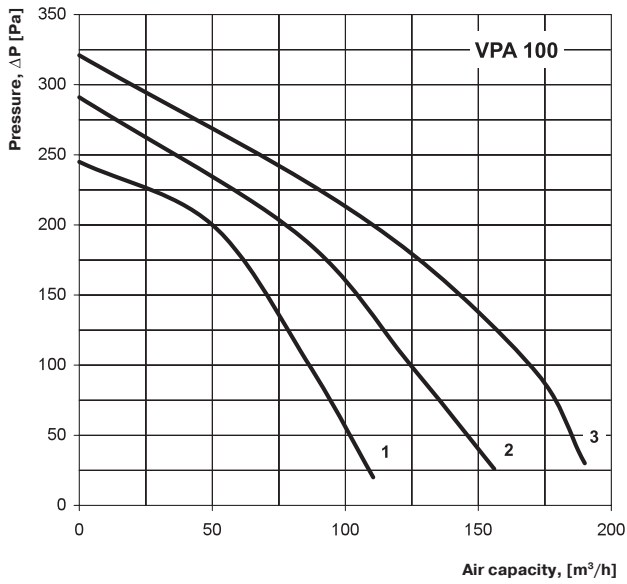

Sound-power level	Hz	Octave-frequency band [Hz]								
		Tot.	63	125	250	500	1000	2000	4000	8000
$L_{WA}$ to inlet	dB(A)	50	30	47	47	35	40	37	28	16
$L_{WA}$ to outlet	dB(A)	58	39	50	56	49	45	42	33	23
$L_{WA}$ to environment	dB(A)	31	5	21	28	24	19	13	4	0

VENTS VPA

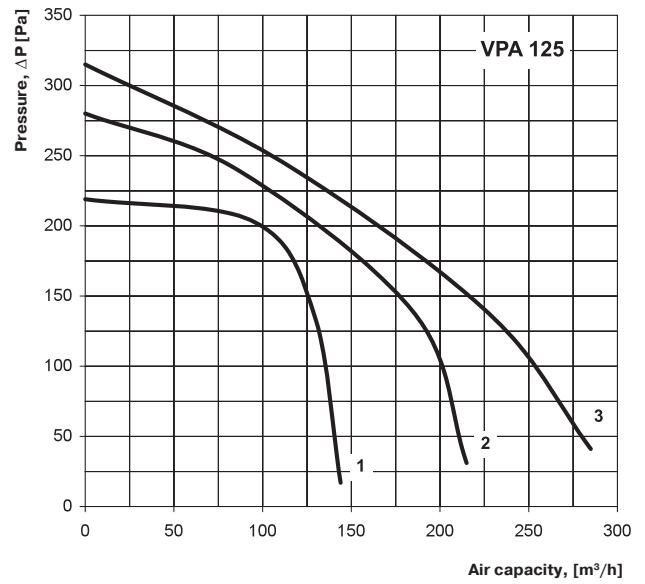

Sound-power level	Hz	Octave-frequency band [Hz]								
		Tot.	63	125	250	500	1000	2000	4000	8000
$L_{WA}$ to inlet	dB(A)	52	31	48	48	36	41	40	32	18
$L_{WA}$ to outlet	dB(A)	62	40	53	56	52	47	47	37	23
$L_{WA}$ to environment	dB(A)	33	9	24	33	26	17	16	3	4

VENTS VPA

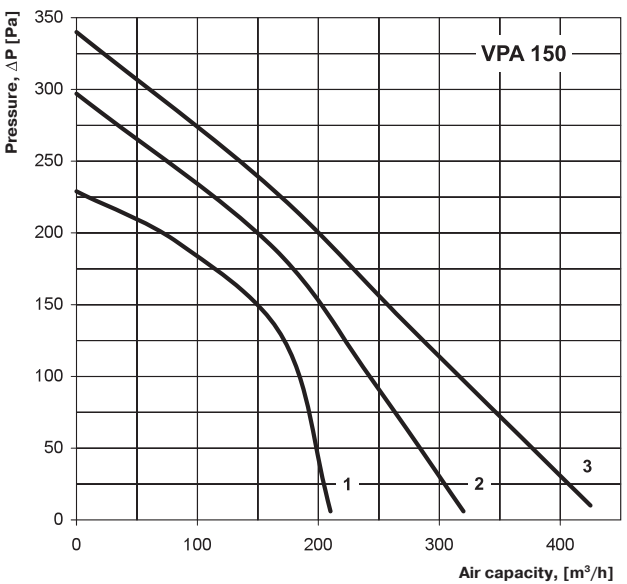

Sound-power level	Hz	Octave-frequency band [Hz]								
		Tot.	63	125	250	500	1000	2000	4000	8000
$L_{WA}$ to inlet	dB(A)	65	37	53	63	50	53	53	45	30
$L_{WA}$ to outlet	dB(A)	63	22	43	53	52	57	57	46	36
$L_{WA}$ to environment	dB(A)	41	14	34	39	19	27	19	7	0

VENTS VPA

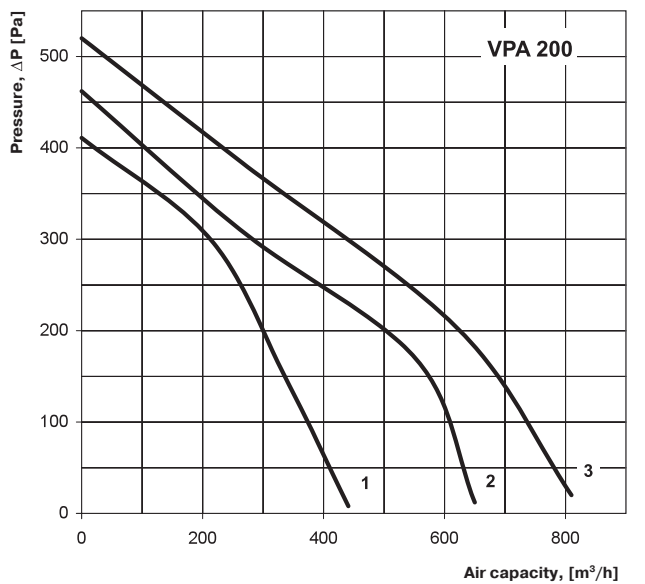

Sound-power level	Hz	Octave-frequency band [Hz]								
		Tot.	63	125	250	500	1000	2000	4000	8000
$L_{WA}$ to inlet	dB(A)	65	41	58	59	56	60	62	56	41
$L_{WA}$ to outlet	dB(A)	71	46	57	63	64	66	66	58	45
$L_{WA}$ to environment	dB(A)	46	15	31	43	40	34	30	22	8

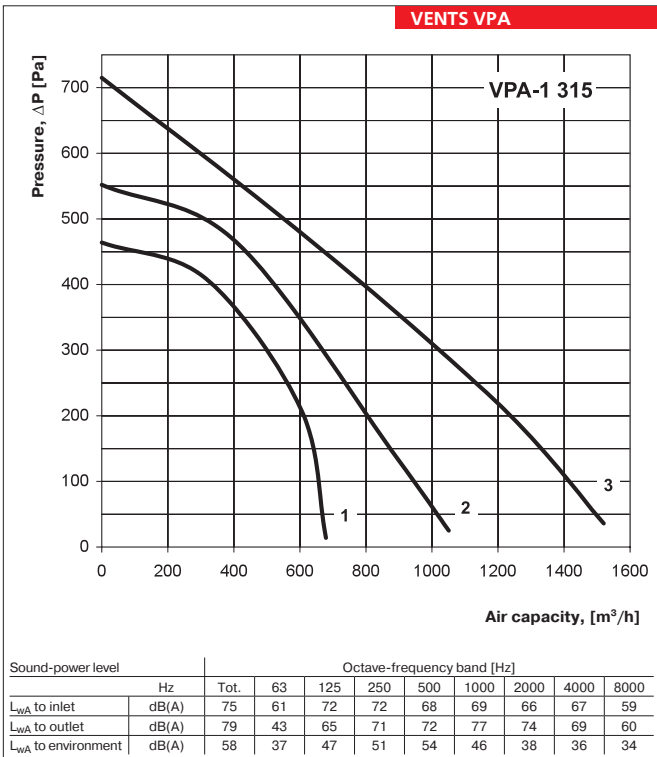
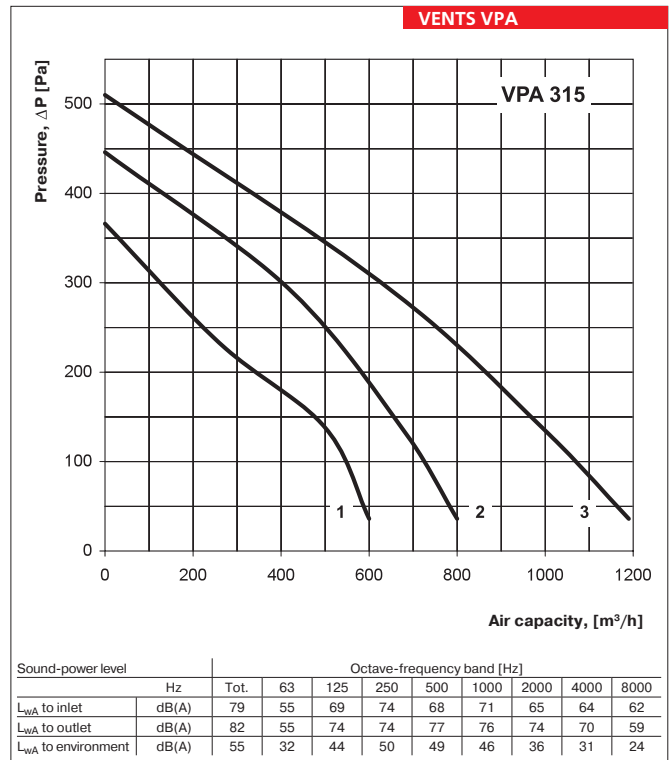
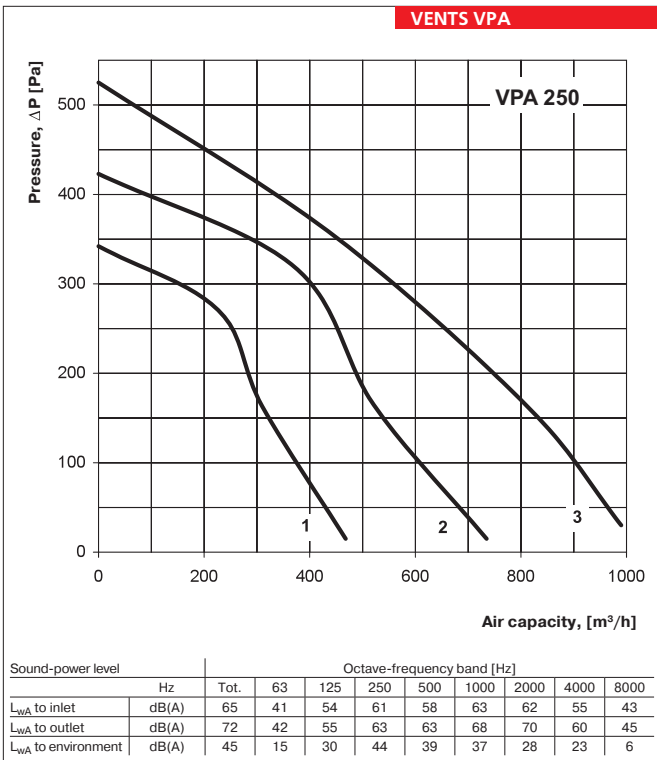

**Accessories to supply units:**

Type	Replaceable filter	Filter type
VPA 100-1,8-1	SF VPA 100/125 G4	panel filter
VPA 125-2,4-1		
VPA 150-2,4-1	SF VPA 150 G4	panel filter
VPA 150-3,4-1		
VPA 150-5,1-3		
VPA 150-6,0-3		
VPA 200-3,4-1	SF VPA 200/250 G4	panel filter
VPA 200-5,1-3		
VPA 200-6,0-3		
VPA 250-3,6-3		
VPA 250-6,0-3	SF VPA 315 G4	panel filter
VPA 250-9,0-3		
VPA 315-6,0-3		
VPA 315-9,0-3	SF VPA 315 G4	panel filter
VPA-1 315-6,0-3		
VPA-1 315-9,0-3		

SUPPLY UNIT SERIES VENTS VPA



Series  
**VENTS MPA E**



LCD control panel

Supply units with the air capacity up to **3500 m<sup>3</sup>/h** in the compact sound- and heat-insulated casing with electric heater

Series  
**VENTS MPA W**



SAS908 control panel

Supply units with the air capacity up to **6500 m<sup>3</sup>/h** in the compact sound- and heat-insulated casing with water heater

■ **Description**

Air supply MPA unit is a complete ventilation unit for air filtration, air heating and supply to premises. Compatible with 400x200, 500x250, 500x300, 600x300, 600x350 and 800x500 mm rectangular air ducts.

■ **Casing**

The casing is made of aluzink with internal 25 mm heat- and sound-insulating layer made of mineral wool.

■ **Filter**

G4 incorporated filter ensures high degree of supply air purification.

■ **Heater**

Both electric heater (MPA E models) and water/glycol heating coils (MPA W models) are used for heating

of supply air during winter and off-season period. Tubular heating elements of the electric fan heater are ribbed to increase the heat exchange surface area and heat transfer to supply air.

■ **Fan**

Centrifugal double-inlet fan with forward-curved blades and built-in overheating protection with automatic restart. The fan motor and impeller are dynamically balanced in two planes. The ball bearings in the electric motor are maintenance free and designed for at least 40000 hours operation.

■ **Control and automation**

Two options for supply unit modifications are possible:

1. No control. Customer-defined and customer-selected automation system.

2. Built-in control and automation system provides the fan air capacity control by means of three speed switching, supply air temperature setting, filter clogging degree control.

Additionally the automation system provides thermal overheating protection for the tubular heating elements. The remote control of the unit is effected by means of external control unit with 10 meters wire supplied as a standard.

Supply units MPA 3200 W, MPA 3500 W, MPA 5000 W have no control panel.

■ **MPA E control and protection functions**

- ▶ remote switching the unit on and off;
- ▶ setting and maintaining the desired temperature of supply air with the control panel;
- ▶ motor speed controlling and regulating the air capacity accordingly by means of the control panel;

**Designation key:** \_\_\_\_\_

Series	Rated air flow, m <sup>3</sup> /h	Heater type	Phase
<b>VENTS MPA</b>	800, 1200, 1800, 2500, 3200, 3500, 5000	<b>E</b> - electrical heating elements; <b>W</b> - water coils;	<b>1</b> – single-phase; <b>3</b> – three-phase

**Accessories**



page 246   page 280   page 282   page 288   page 297   page 298   page 301   page 302

**Offered options to the units**



page 168   page 168



- ▶ working-out of the required patterns during the unit switching on and off;
- ▶ unit timer-dependent operation;
- ▶ active electric heating elements overheating protection;
- ▶ disabling electric air heater operation when the motor is not running;
- ▶ two electric heater over-heating thermostats;
- ▶ filter clogging control through the differential pressure sensor.

**■ MPA W control and protection functions**

- ▶ switching the unit on and off;
- ▶ switching to one of three available motor speed;
- ▶ keeping the set temperature of supply air by means of controlling the three-way valve actuator that regulates the heat medium supply to the heater;
- ▶ water (glycol) heating coils freezing protection

as the leaving air temperature and leaving heat medium temperature sensors require;

- ▶ controlling the of external circulation pump operation installed on the heat medium entering into the water (glycol) coils;
- ▶ controlling the condensing unit of the air cooler with respect to the indoor temperature in case of additional air cooler in the duct;
- ▶ controlling supply fan operation;
- ▶ air filter clogging control;
- ▶ controlling the external air damper actuator;
- ▶ emergency stop on fire alarm signal.

Due to the mixing unit the control panel can keep the set indoor temperature by means of regulating the heat medium flow through the water (glycol) coils. The use of the mixing unit with the pump provides the referred above regulation with the pressure difference of the heat medium in the main

and return line below 40 kPa. The mixing unit with the pump serves for freezing protection of the heat exchanger and its operation algorithm provides some time span for the users to take required measures in case of emergency.

**■ Mounting**

The supply unit can be mounted on the floor, suspended to the ceiling by means of a seat angle with a flexible connector or fixed to the wall using brackets. The unit can be installed either in such service spaces as balcony, storeroom, basement, roof space or in main premises above the suspended ceiling, in the pocket or placed directly in the room. The unit can be mounted in any position but the vertical one with air downstream because the heating elements are not allowed under the fan. Access for the unit maintenance and filter cleaning shall be provided.

**Unit overall dimensions:**

Type	Dimensions, [mm]									
	B	B1	B2	B3	H	H1	H2	L	L1	L2
MPA 800 E1	400	420	549	500	200	220	352	650	530	-
MPA 1200 E3	400	420	549	500	200	220	352	650	530	-
MPA 1800 E3	500	520	649	600	250	270	480	800	680	-
MPA 2500 E3	500	520	649	600	300	320	480	800	680	-
MPA 3200 E3	600	620	759	710	300	320	530	1000	880	440
MPA 3500 E3	600	620	759	710	350	370	530	1000	880	440

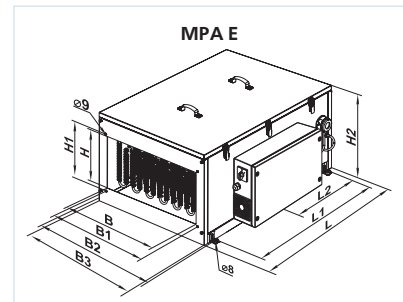

**Unit overall dimensions:**

Type	Dimensions, [mm]									
	B	B1	B2	B3	H	H1	H2	L	L1	L2
MPA 800 W	400	420	549	500	200	220	352	650	530	-
MPA 1200 W	400	420	549	500	200	220	352	650	530	-
MPA 1800 W	500	520	649	600	250	270	480	800	680	-
MPA 2500 W	500	520	649	600	300	320	480	800	680	-
MPA 3200 W	600	620	759	710	300	320	530	1000	880	440
MPA 3500 W	600	620	759	710	350	370	530	1000	880	440
MPA 5000 W	800	820	971	925	500	520	670	1299	720	360

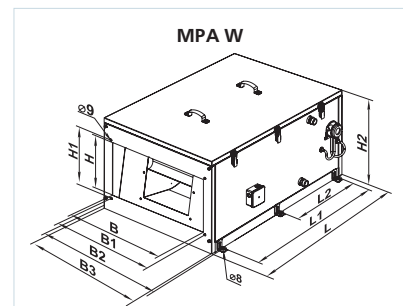

VENTS  
MPA E /  
MPA W  
SUPPLY UNIT SERIES

## SUPPLY UNITS

### Technical data:

	MPA 800 E1	MPA 800 W	MPA 1200 E3	MPA 1200 W
Unit supply voltage [V / 50 Hz]	1~ 230		3~ 400	1~ 230
Maximum fan power [W]	245		410	
Fan current [A]	1,08		1,8	
Electric heater capacity [kW]	3,3	-	9,9	-
Electric heater current [A]	14,3	-	24,8	-
Number of water (glycol) coil rows	-	4	-	4
Total power of the unit [kW]	3,55	0,245	9,94	0,410
Total current of the unit [A]	15,38	1,08	26,6	1,8
Air capacity [m <sup>3</sup> /h]	800	750	1200	1200
RPM	1650		1850	
Noise level at 3m [dB[A]]	35		38	
Operating temperature [°C]	-25 up to +45		-25 up to +45	
Casing material	aluzink		aluzink	
Insulation	25 mm mineral wool		25 mm mineral wool	
Filter	G4		G4	
Connected air duct size [mm]	400x200		400x200	
Weight, [kg]	36,2	41,3	38,9	42,8

\* no control box (with the control box for MPA...E +130 mm)

### Technical data:

	MPA 1800 E3	MPA 1800 W	MPA 2500 E3	MPA 2500 W
Unit supply voltage [V / 50 Hz]	3~ 400	1~ 230	3~ 400	1~ 230
Maximum fan power [W]	490		650	
Fan current [A]	2,15		2,84	
Electric heater capacity [kW]	18,0	-	18,0	-
Electric heater current [A]	45,0	-	45,0	-
Number of water (glycol) coil rows	-	4	-	4
Total power of the unit [kW]	18,49	0,490	18,65	0,650
Total current of the unit [A]	47,15	2,15	47,84	2,84
Air capacity [m <sup>3</sup> /h]	2000	1870	2500	2150
RPM	1100		1000	
Noise level at 3m [dB[A]]	40		45	
Operating temperature [°C]	-25 up to +45		-25 up to +45	
Casing material	aluzink		aluzink	
Insulation	25 mm mineral wool		25 mm mineral wool	
Filter	G4		G4	
Connected air duct size [mm]	500x250		500x300	
Weight, [kg]	61,5	62,5	62	63

\* no control box (with the control box for MPA...E +130 mm)

**Technical data:**

	MPA 3200 E3	MPA 3200 W	MPA 3500 E3	MPA 3500 W	MPA 5000 W
Unit supply voltage [V / 50 Hz]	3~ 400Y		3~ 400Y		3~ 400
Maximum fan power [W]	1270		1270		1800
Fan current [A]	2,3		2,3		4,5
Electric heater capacity [kW]	25,2	-	25,2	-	-
Electric heater current [A]	63,0	-	63,0	-	-
Number of water (glycol) coil rows	-	4	-	4	4
Total power of the unit [kW]	26,47	1,270	26,47	1,270	1,80
Total current of the unit [A]	65,3	2,3	65,3	2,3	4,5
Air capacity [m³/h]	3200	3000	3500	3250	6500
RPM	1200		1200		1400
Noise level at 3m [dB(A)]	53		53		55
Operating temperature [°C]	-40 up to +45		-40 up to +45		-25 up to +45
Casing material	aluzink		aluzink		aluzink
Insulation	25 mm mineral wool		25 mm mineral wool		
Filter	G4		G4		G4
Connected air duct size [mm]	600x300		600x350		800x500
Weight, [kg]	69,4	73,2	69,3	73,1	136

\* no control box (with the control box for MPA...E +130 mm)

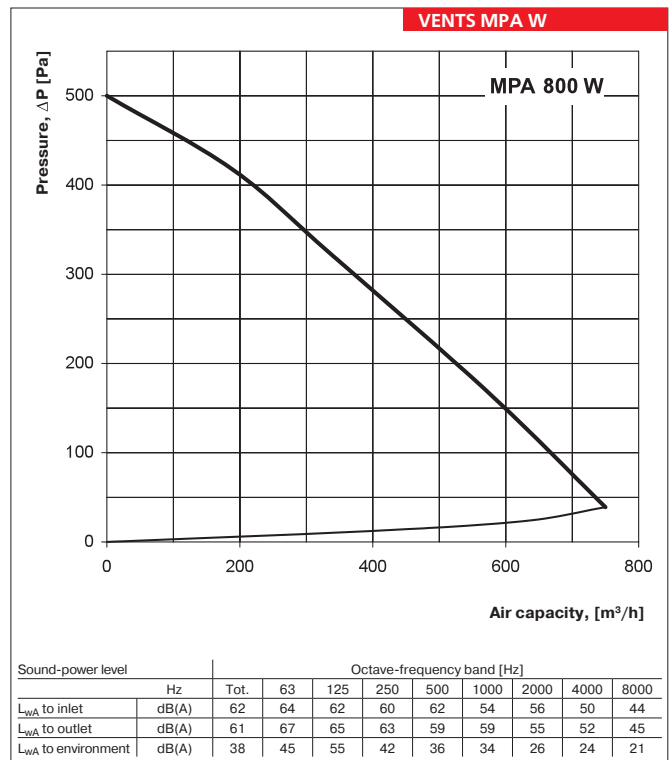
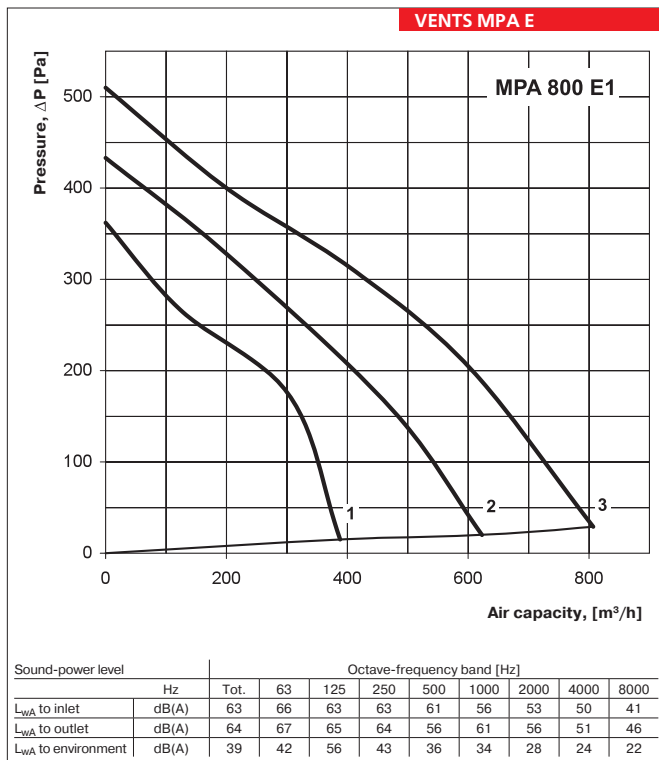

VENTS  
 MPA E /  
 MPA W  
 SUPPLY UNIT SERIES

VENTS MPA E

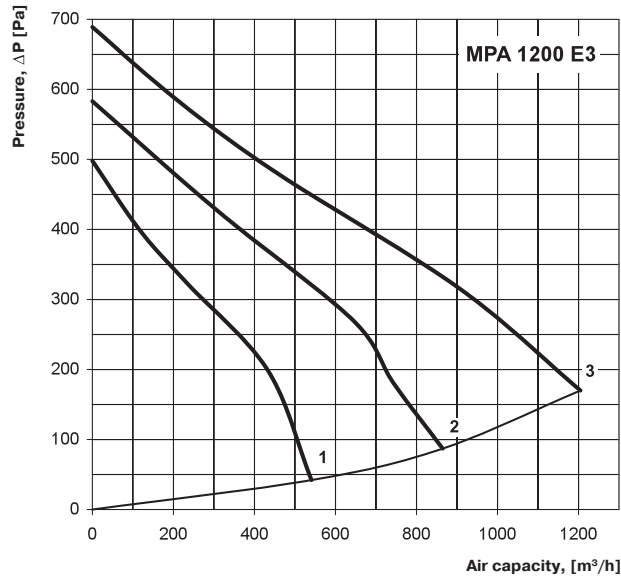

Sound-power level	Hz	Octave-frequency band [Hz]								
		Tot.	63	125	250	500	1000	2000	4000	8000
$L_{WA}$ to inlet	dB(A)	67	66	66	68	66	60	63	60	55
$L_{WA}$ to outlet	dB(A)	72	71	70	68	68	65	60	60	57
$L_{WA}$ to environment	dB(A)	45	55	54	48	52	40	37	34	35

VENTS MPA W

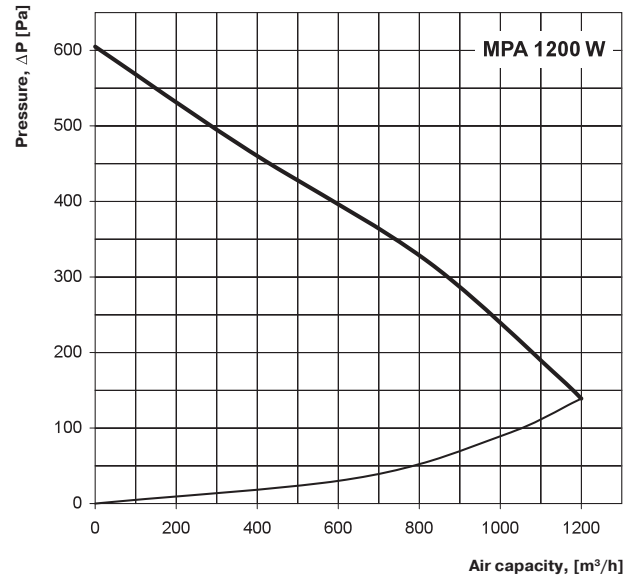

Sound-power level	Hz	Octave-frequency band [Hz]								
		Tot.	63	125	250	500	1000	2000	4000	8000
$L_{WA}$ to inlet	dB(A)	71	70	68	66	68	62	61	61	56
$L_{WA}$ to outlet	dB(A)	71	68	69	67	64	67	62	61	57
$L_{WA}$ to environment	dB(A)	48	56	54	48	53	40	39	35	33

VENTS MPA E

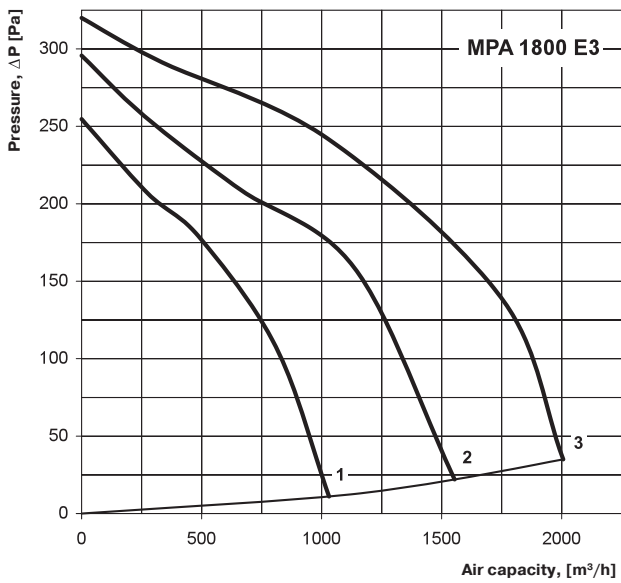

Sound-power level	Hz	Octave-frequency band [Hz]								
		Tot.	63	125	250	500	1000	2000	4000	8000
$L_{WA}$ to inlet	dB(A)	74	79	76	74	67	67	64	64	54
$L_{WA}$ to outlet	dB(A)	75	82	78	74	68	73	66	70	67
$L_{WA}$ to environment	dB(A)	52	64	62	54	48	44	40	36	34

VENTS MPA W

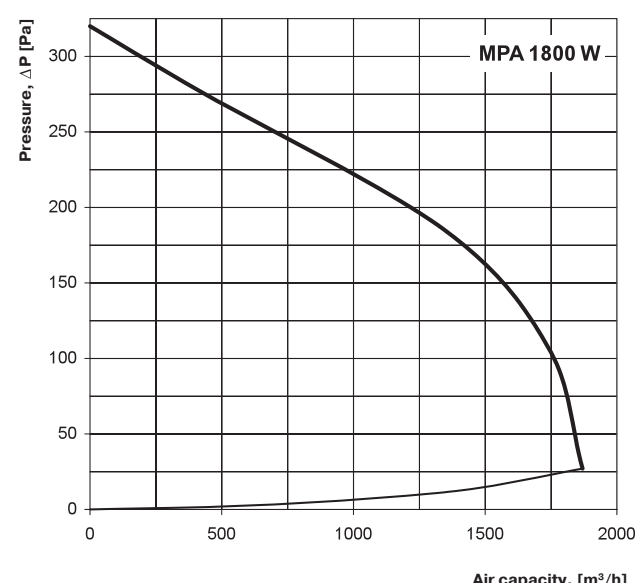

Sound-power level	Hz	Octave-frequency band [Hz]								
		Tot.	63	125	250	500	1000	2000	4000	8000
$L_{WA}$ to inlet	dB(A)	73	78	77	77	67	68	62	63	57
$L_{WA}$ to outlet	dB(A)	75	79	78	74	68	73	66	69	66
$L_{WA}$ to environment	dB(A)	51	63	61	54	47	44	40	37	33

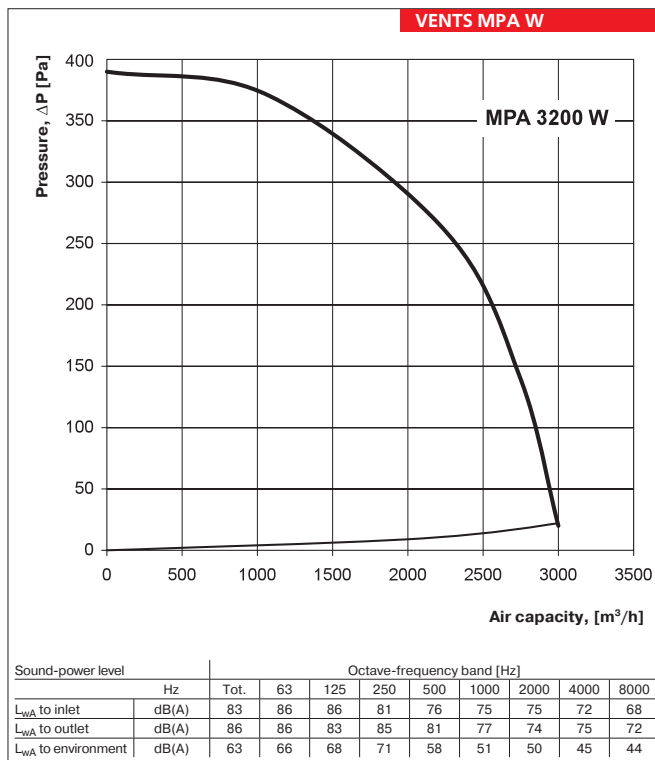
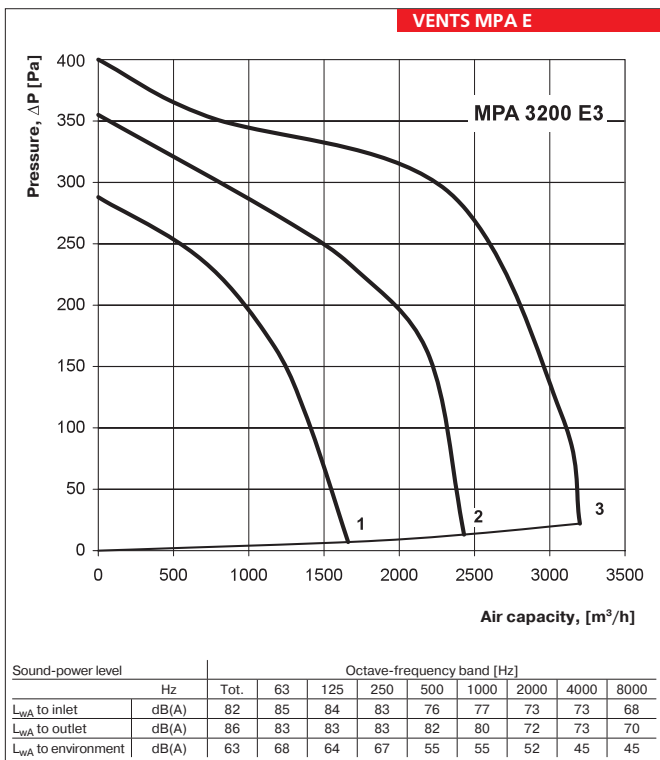
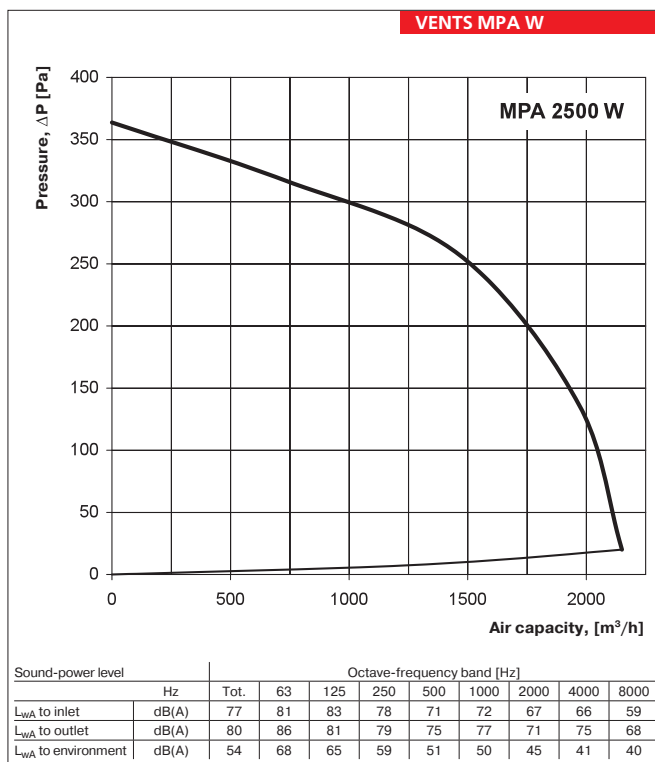
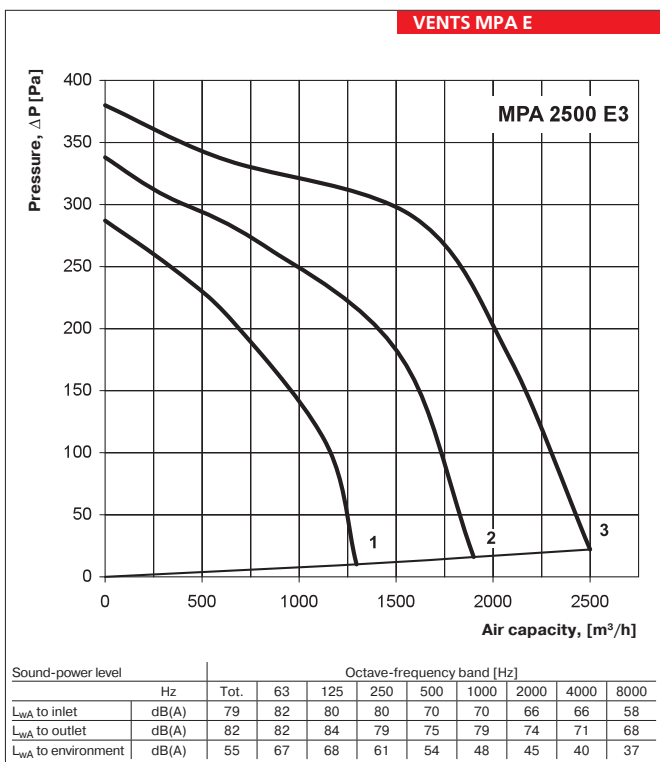

VENTS  
MPA E /  
MPA W

SUPPLY UNIT SERIES

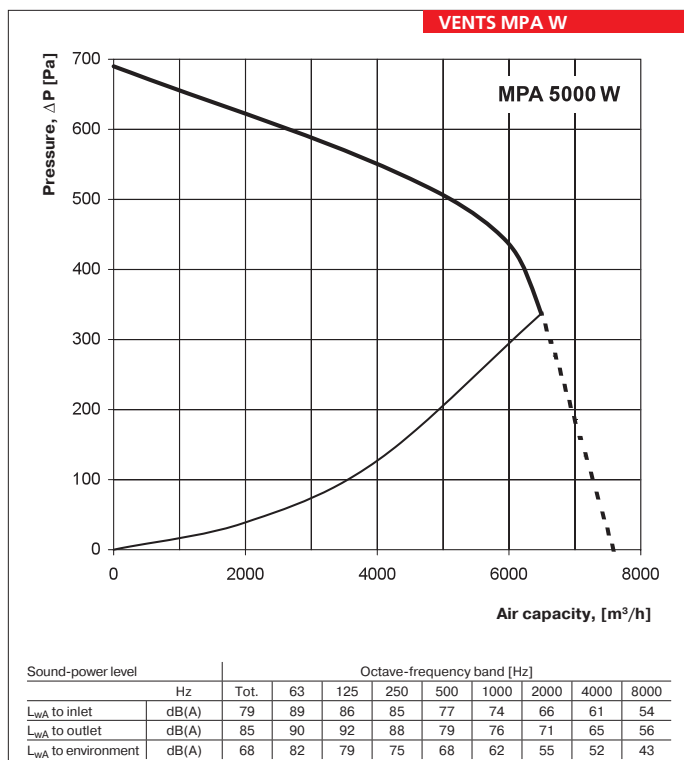
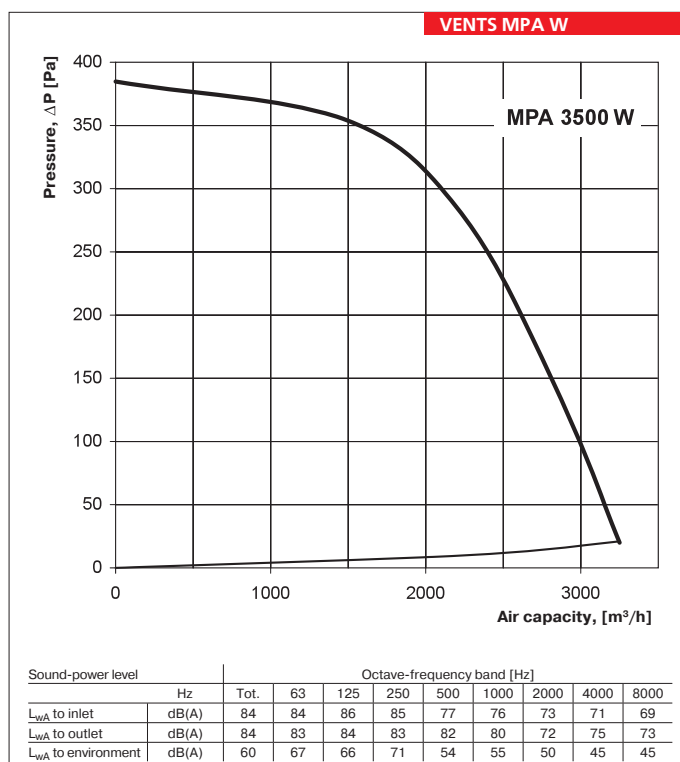
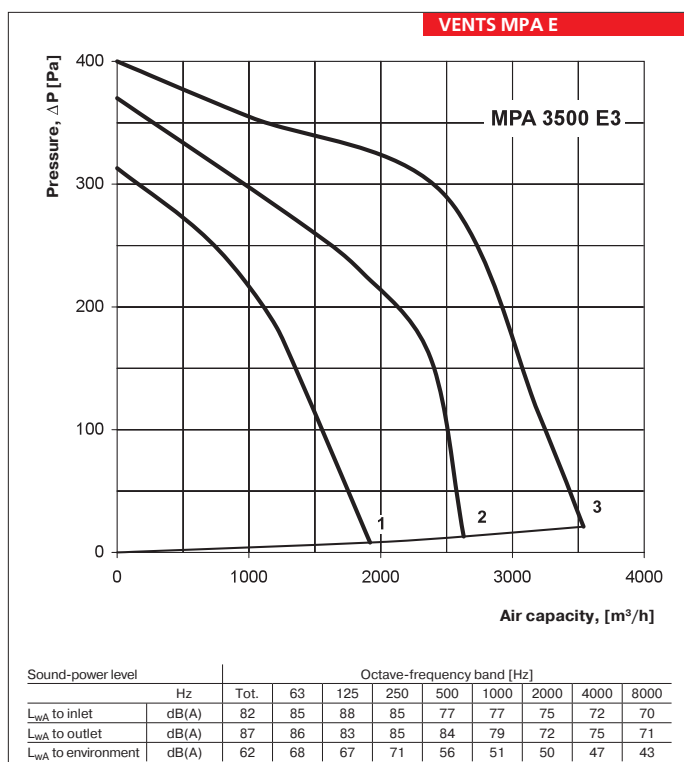

**Accessories to supply units:**

Type	Replaceable filter	Filter type
MPA 800 E1	SF MPA 800/1200 G4	panel filter
MPA 1200 E3		
MPA 1800 E3	SF MPA 1800/2500 G4	panel filter
MPA 2500 E3		
MPA 3200 E3	SF MPA 3200/3500 G4	panel filter
MPA 3500 E3		
MPA 800 W	SF MPA 800/1200 G4	panel filter
MPA 1200 W		
MPA 1800 W	SF MPA 1800/2500 G4	panel filter
MPA 2500 W		
MPA 3200 W	SF MPA 3200/3500 G4	panel filter
MPA 3500 W		
MPA 5000 W	SFK MPA 5000 G4	pocket filter



### Office ventilation example

Air supply and exhaust ventilation in the modern office can be arranged as follows. Air handling MPA unit, exhaust fan complying with MPA unit characteristics, intake and exhaust main air ducts are mounted in the hall behind the suspended ceiling. The branchings are laid into the office premises and air distribution units.

Intake air from outside flows through the external grille, is filtered in the air handling unit, heated to the required temperature and supplied to the office rooms through the branch duct system. Exhaust air is extracted outside through the external grille by means of the exhaust fan. Thus the office has the permanent fresh air supply, controllable air exchange, no draughts when opened windows, no dust and no noise.



MPA unit office air exchange example.

Hot water coil parameters:

VENTS MPA W

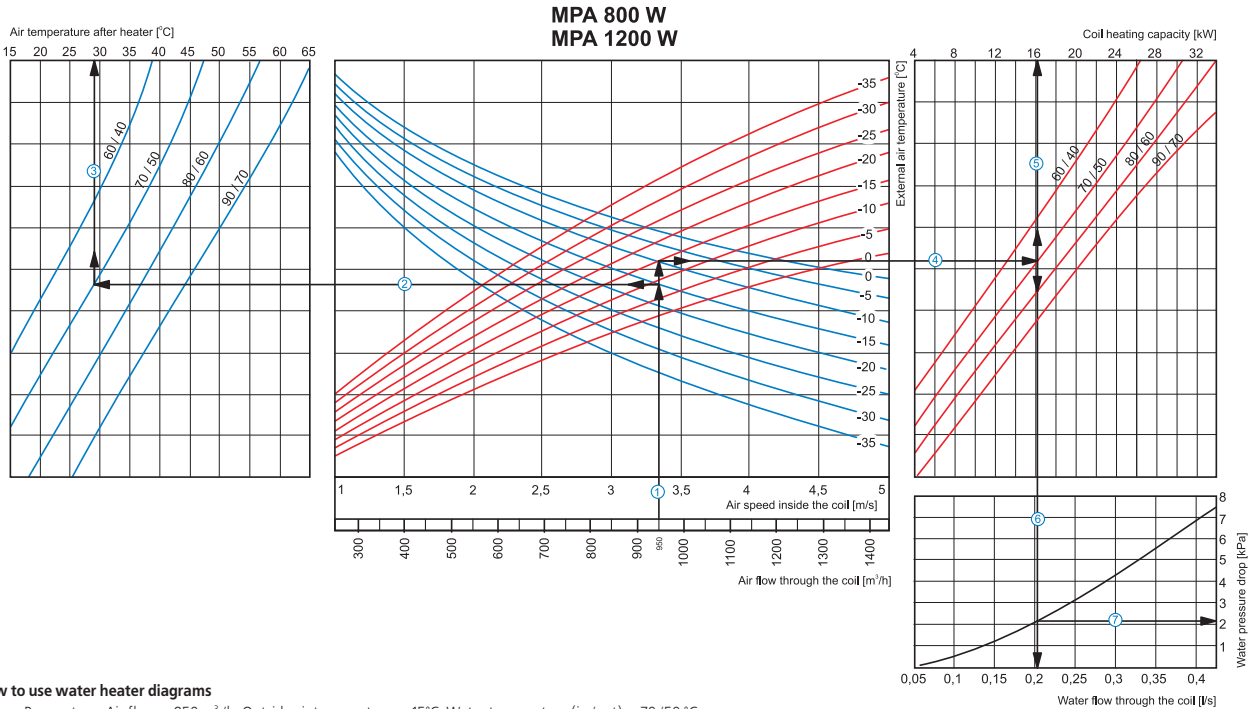

How to use water heater diagrams

System Parameters: Air flow = 950 m<sup>3</sup>/h. Outside air temperature = -15°C. Water temperature (in/out) = 70/50°C.

- Air Speed. Starting from 950 m<sup>3</sup>/h on the air flow scale draw a vertical line ① till the air speed axis which makes about 3.35 m/s.
- Supply air temperature. Prolong the line ① up to the point where it crosses the outside air temperature (blue curve), e.g. -15°C; then draw a horizontal line ② from this point to the left till crossing water in/out temperature curve (70/50 °C). From this point draw a vertical line ③ to the supply air temperature axis on top of the graphic (+29 °C).
- Heating coil capacity. Prolong the line ① up to the point where it crosses the outside air temperature -15°C (red curve) and draw a horizontal line ④ from this point to the right until it crosses water in/out temperature curve (70/50 °C), from here draw a vertical line ⑤ up to the scale representing the heating coil capacity (16 kW).
- Water flow. Prolong the line ⑤ down to water flow axis at the bottom of the graphic ⑥ (0.2 l/s).
- Water pressure drop. Draw the line ⑦ from the point where line ⑥ crosses the black curve to the pressure drop axis. (2.1 kPa).

VENTS MPA W

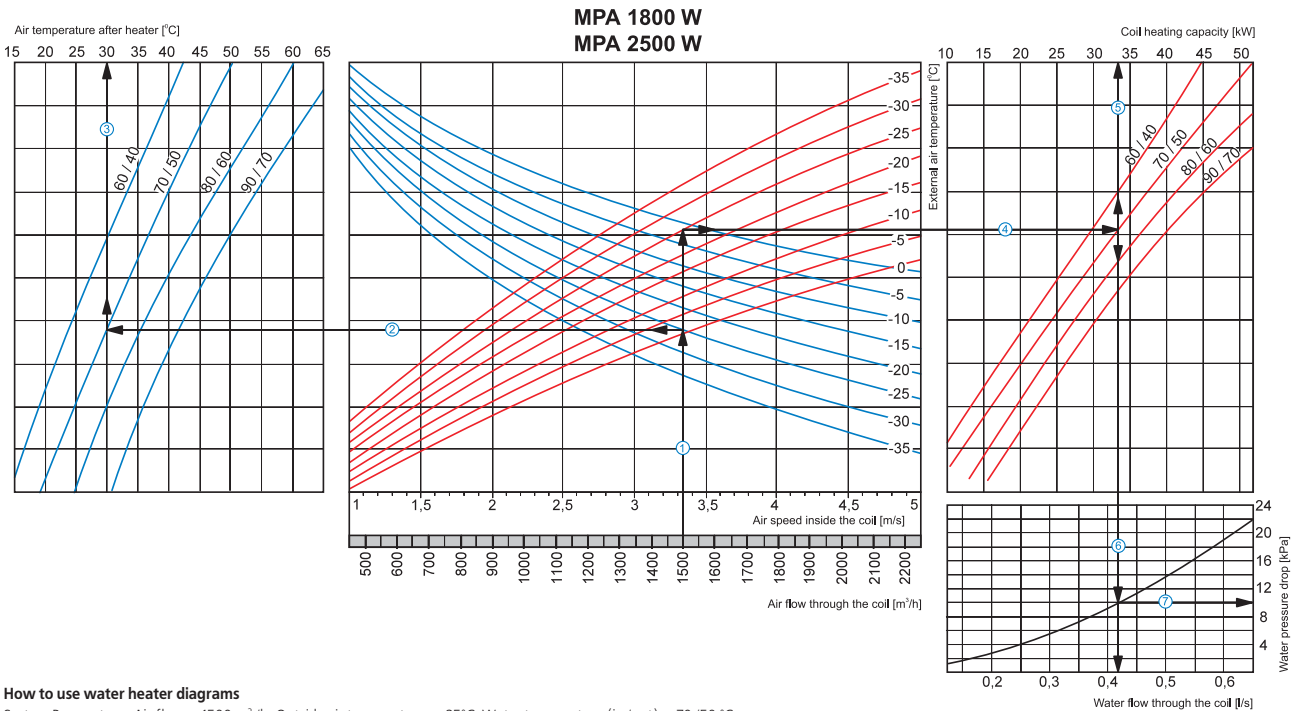

How to use water heater diagrams

System Parameters: Air flow = 1500 m<sup>3</sup>/h. Outside air temperature = -25°C. Water temperature (in/out) = 70/50 °C.

- Air Speed. Starting from 1500 m<sup>3</sup>/h on the air flow scale draw a vertical line ① till the air speed axis which makes about (3.3 m/s).
- Supply air temperature. Prolong the line ① up to the point where it crosses the outside air temperature (blue curve), e.g. -25°C; then draw a horizontal line ② from this point to the left till crossing water in/out temperature curve (70/50 °C). From this point draw a vertical line ③ to the supply air temperature axis on top of the graphic (+30 °C).
- Heating coil capacity. Prolong the line ① up to the point where it crosses the outside air temperature -25°C (red curve) and draw a horizontal line ④ from this point to the right until it crosses water in/out temperature curve (70/50 °C), from here draw a vertical line ⑤ up to the scale representing the heating coil capacity (33.0 kW).
- Water flow. Prolong the line ⑤ down to water flow axis at the bottom of the graphic ⑥ (0.42 l/s).
- Water pressure drop. Draw the line ⑦ from the point where line ⑥ crosses the black curve to the pressure drop axis. (10.0 kPa).

**Hot water coil parameters:**

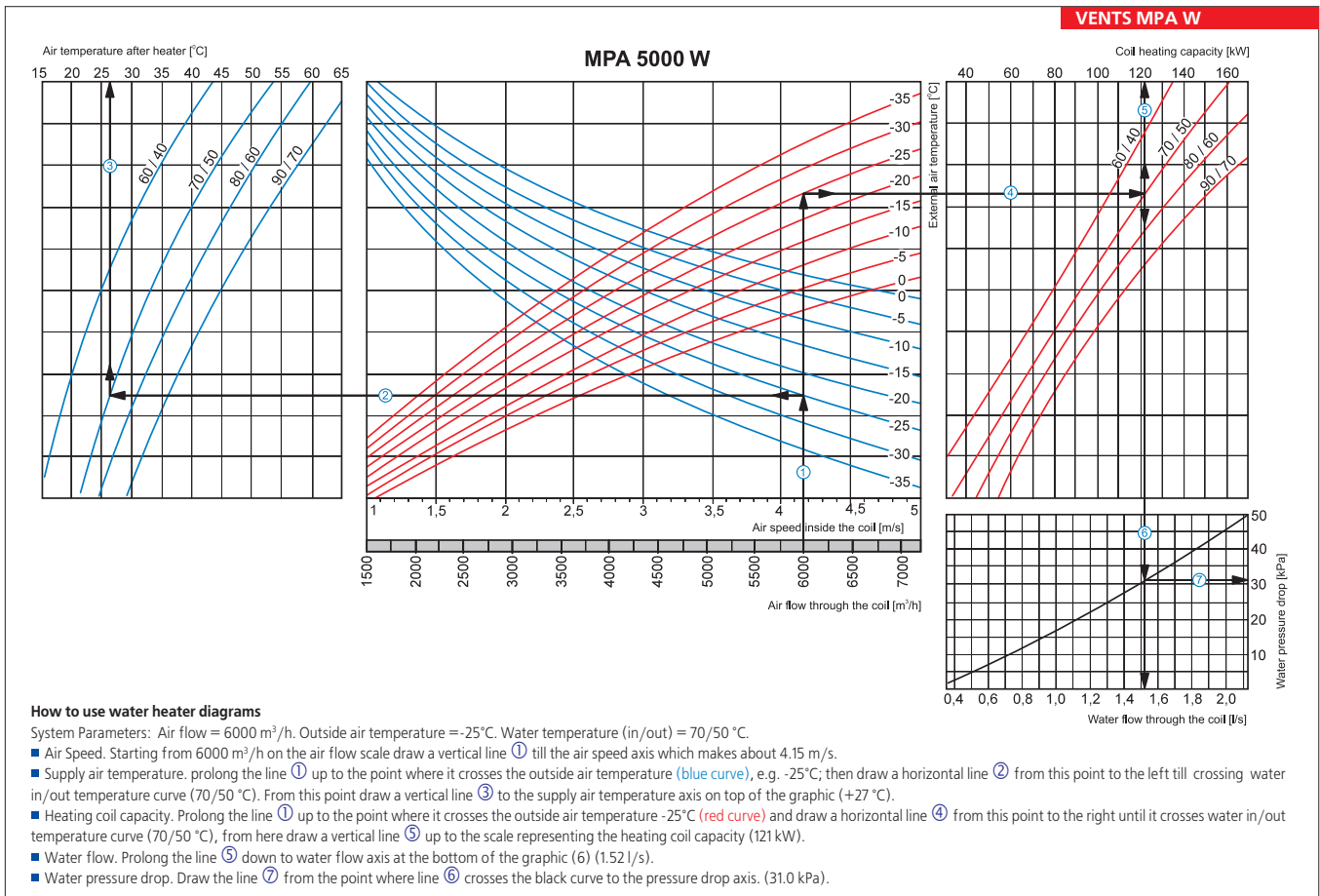
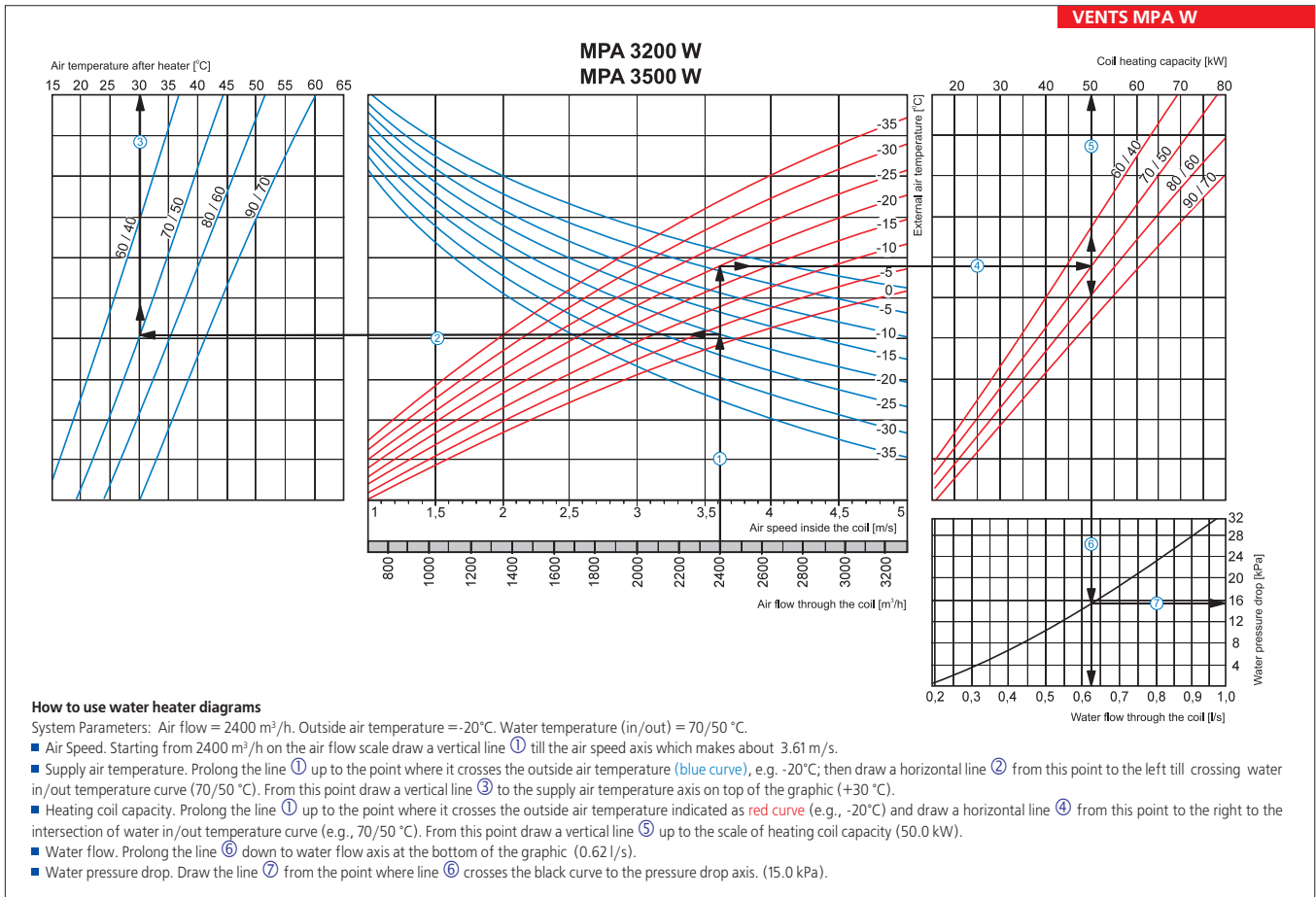

VENTS  
MPA E /  
MPA W

SUPPLY UNIT SERIES

Series  
**VENTS PA...E**



Suspended air supply units with the air capacity up to **3350 m<sup>3</sup>/h** in the sound- and heat-insulated casing with the electric heater

Series  
**VENTS PA...W**



SAS908 control panel

Suspended air supply units with the air capacity up to **4100 m<sup>3</sup>/h** in the sound- and heat-insulated casing with the water heater

■ **Description**

Supply unit PA is a complete ventilation unit to provide air filtration, heating and fresh air supply to the premises. To ensure the balanced ventilation VA exhaust unit which has the same fans as PA unit can be connected to PA exhaust unit. VA unit shall operate in coordination with PA unit.

■ **Casing**

The casing is made of aluminum-zinc steel plates with 50 mm thermal and sound insulating layer made of mineral wool.

■ **Filter**

The units are supplied with built-in G4 panel filter for supply air filtration. F7 filter is available as an option.

■ **Heater**

PA units are equipped both with electrical (PA...E) and water (PA...W) heaters. Depending upon the power required 2, 3 or 4 rows of water coils are installed.

■ **Fan**

The unit is equipped with the direct-driven plug fan incorporating the high-pressure centrifugal impeller with the backward curved blades driven by the external rotor motor. Such fan configuration ensures the best operating characteristics as air capacity, noise level and efficiency. The fan can be easily removed from the casing for inspection and cleaning.

■ **Mounting**

The unit is designed for indoor installation either on the floor, on the wall or under the ceiling by means of a seat angle with inserted vibration-damping element or attached to a wall with brackets. The unit can be mounted either in service spaces or in main premises above the suspended ceiling, in the pocket or the unit can be placed directly in the room. All the electrical connections are performed through the terminal box placed in the connection box. PA supply units are supplied with the fastening brackets to facilitate mounting. The unit can be mounted in any position but the vertical one with vertical air

downstream because the electrical heating elements are not allowed under the fan. Access for the unit maintenance and filter cleaning shall be provided.

■ **Control and automation**

The supply units are available in two modifications:

1. No control system. Customer-defined and customer-selected automation system.
2. Integrated control and automation system ensure air capacity control by means of three speed switching setting temperature of supply air, filter clogging etc. In addition, the automation system provides heating elements overheating protection for PA...E modification. Remote control of the unit is effected by means of the external wire control panel.

Remote control panel provides:

- ▶ ventilation unit remote on/off switching;
- ▶ setting the required air capacity;
- ▶ setting the expected air supply temperature;
- ▶ displaying indoor temperature;
- ▶ failure (alarm) indication.

Remote control panel provides:

- ▶ ventilation unit remote on/off switching;
- ▶ setting the required air capacity;
- ▶ setting the expected air supply temperature;
- ▶ displaying indoor temperature;
- ▶ failure (alarm) indication.

PA 04 W2, PA 04 W3 supply units have no control panel.

**Designation key:** \_\_\_\_\_

Series <b>VENTS PA</b>	Unit standard size 01; 02; 03; 04	Heater type <b>E</b> – electrical; <b>W</b> – water	Row number of the heater <b>2</b> – two rows; <b>3</b> – three rows; <b>4</b> – four rows
---------------------------	--------------------------------------	---	--

**Accessories**



page 246    page 280    page 282    page 288    page 297    page 298    page 301    page 302

**Offered options to the units**



page 175    page 175

**■ PA...E control and protection functions**

- ▶ safe remote start-up and shutdown of the unit;
- ▶ setting and maintaining the desired temperature of the supply air with the control panel (electric air heating element control by means of the optosymistor);
- ▶ fan speed control by means of the control panel;
- ▶ trying-out of the required patterns during the unit switching on and off;
- ▶ unit timer-dependent operation;
- ▶ active electric heating elements overheating protection;
- ▶ disabling the electric heater operation when the motor is not running;
- ▶ electric heater overheating protection by means of two thermostats;
- ▶ filter clogging control (differential pressure sensor).

**■ PA...W control and protection functions**

The regulating stations designed for systems with cooling coils are additionally equipped with the room temperature sensor. Components of the heater manifold (pump, valve with actuator etc.) are not included in the equipment list.

**■ Functionality**

1. Automatic control of RRVA air flow regulating damper.
2. Filter clogging control and indication.
3. Smooth fan speed control (3-380 V at 50 Hz).
4. Maintaining the set temperature of supply air or indoor air temperature.
5. Water heating coils operation control.
6. Control of compressor-condenser block (CCB) for systems supplied with freon cooling coils.

7. Exhaust fan startup signal.

8. Individual adjustability of all parameters for ventilation system.
9. Emergency stop on fire alarm signal.

**■ Supplementary equipment**

The unit can be equipped with the air flow regulating damper, flexible connectors (or clamps) and mixing set for models with the water heating coils and the cooling coils to be installed in the air duct after PA unit.

**Unit overall dimensions:**

Type	Dimensions, [mm]								
	B	B1	B2	B3	H	H1	H2	L	L1
PA 01 E	400	420	624	582	200	220	374	1145	1106
PA 02 E	500	520	689	646	300	320	447	1250	1212
PA 03 E	600	620	888	744	350	370	500	1252	1212
PA 01 W	400	420	624	582	200	220	374	1145	1106
PA 02 W	500	520	689	646	300	320	447	1250	1212
PA 03 W	600	620	787	744	350	370	500	1252	1212
PA 04 W	700	720	888	844	400	420	546	1302	1262

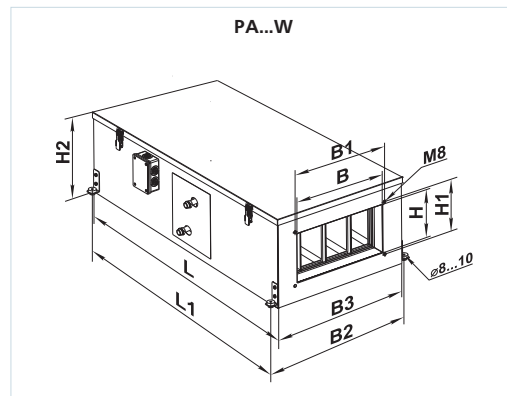
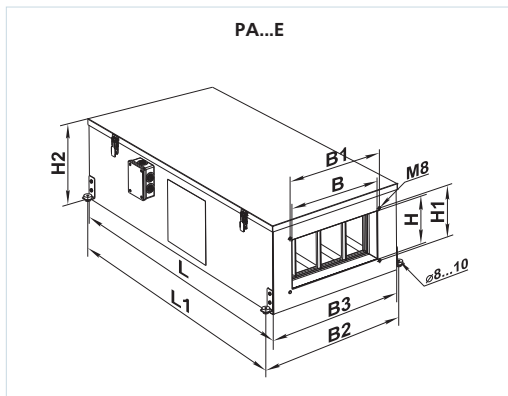

VENTS  
PA E / PA W  
SUPPLY UNIT SERIES



## SUPPLY UNITS

### Technical data:

	PA 01 E	PA 01 W2	PA 01 W4	PA 02 E	PA 02 W2	PA 02 W4
Unit supply voltage [V / 50 Hz]	3~ 400			3~ 400		
Maximum fan power [W]	320			620		
Fan current [A]	0,55			1,05		
Electric heater capacity [kW]	12,0	-		18,0	-	
Electric heater current [A]	17,4	-		26,0	-	
Number of water (glycol) coil rows	-	2	4	-	2	4
Total power of the unit [kW]	12,32	0,32		18,62	0,62	
Total current of the unit [A]	17,95	0,55		27,05	1,05	
Air capacity [m <sup>3</sup> /h]	1275	1200		2500	2350	
RPM	2700			2690		
Noise level at 3m [dB(A)]	51			54		
Operating temperature [°C]	-25 up to +55			-25 up to +45		
Casing material	aluzink			aluzink		
Insulation	50 mm, mineral wool			50 mm, mineral wool		
Filter	panel filter G4	G4 (F7) pocket type*		panel filter G4	G4 (F7) pocket type*	
Connected air duct size [mm]	400x200			500x300		
Weight, [kg]	56	55	57	61	61	63

\*option

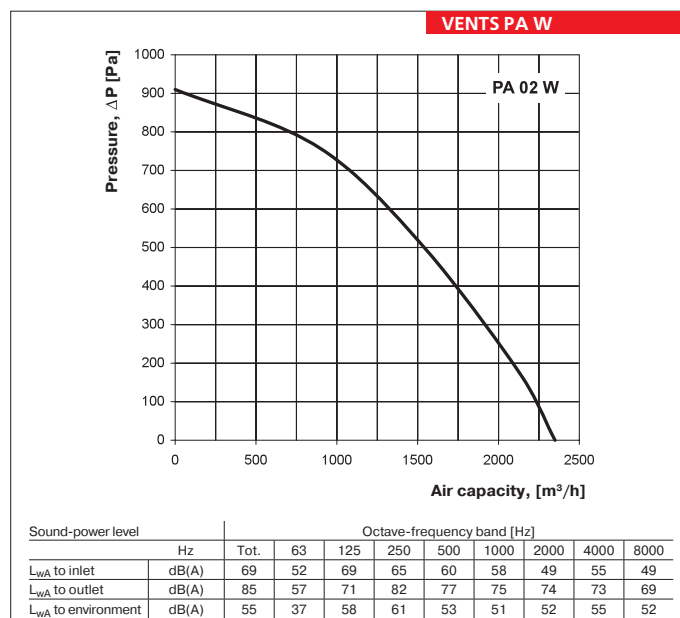
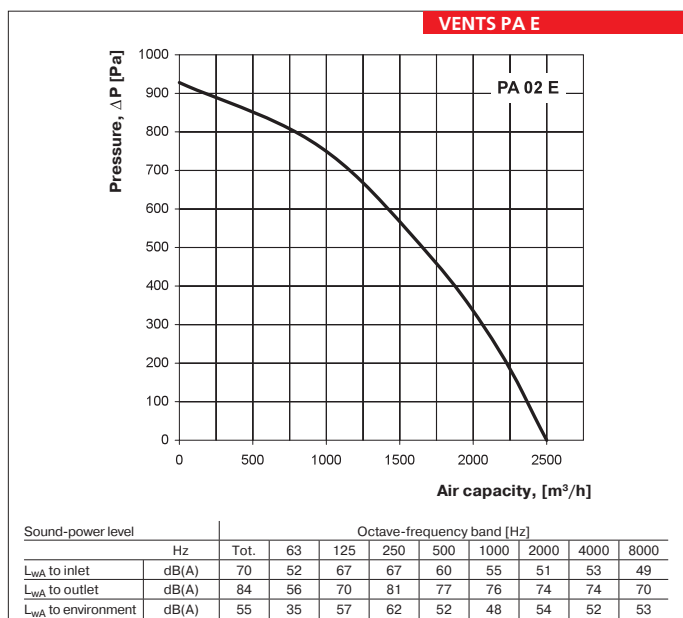
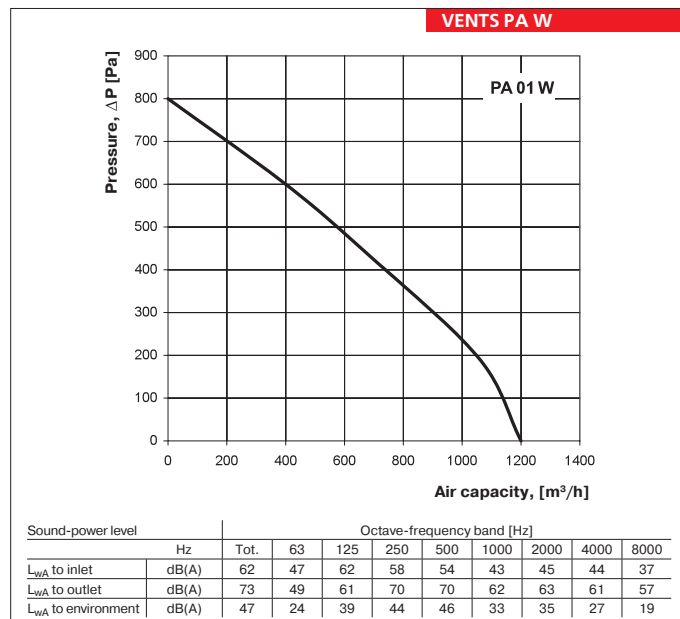
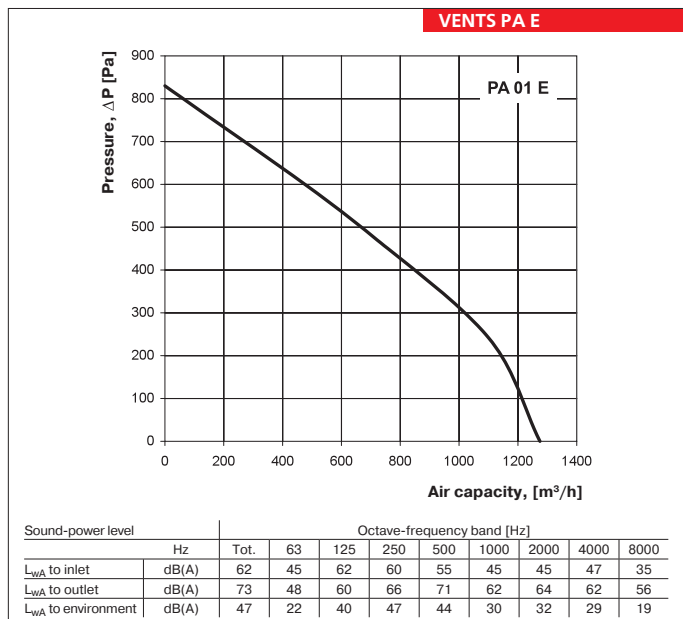



**Technical data:**

	PA 03 E	PA 03 W2	PA 03 W4	PA 04 W2	PA 04 W3
Unit supply voltage [V / 50 Hz]		3~ 400		3~ 400	
Maximum fan power [W]		1330		2300	
Fan current [A]		2,4		4,3	
Electric heater capacity [kW]	21,0	-		-	
Electric heater current [A]	30,0	-		-	
Number of water (glycol) coil rows	-	2	4	2	3
Total power of the unit [kW]	22,33	1,33		2,30	
Total current of the unit [A]	32,4	2,4		4,3	
Air capacity [m³/h]	3350	3260		4100	
RPM		2730		2840	
Noise level at 3m [dB(A)]		57		58	
Operating temperature [°C]		-25 up to +45		-25 up to +70	
Casing material		aluzink		aluzink	
Insulation		50 mm, mineral wool		50 mm, mineral wool	
Filter	panel filter G4	G4 (F7) pocket type*		G4 (F7) pocket type*	
Connected air duct size [mm]		600x350		700x400	
Weight, [kg]	91	91	94	107	110

\*option

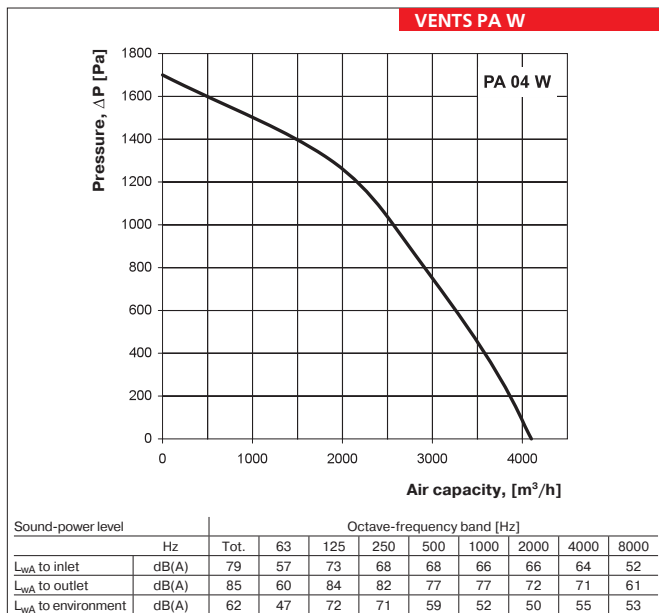
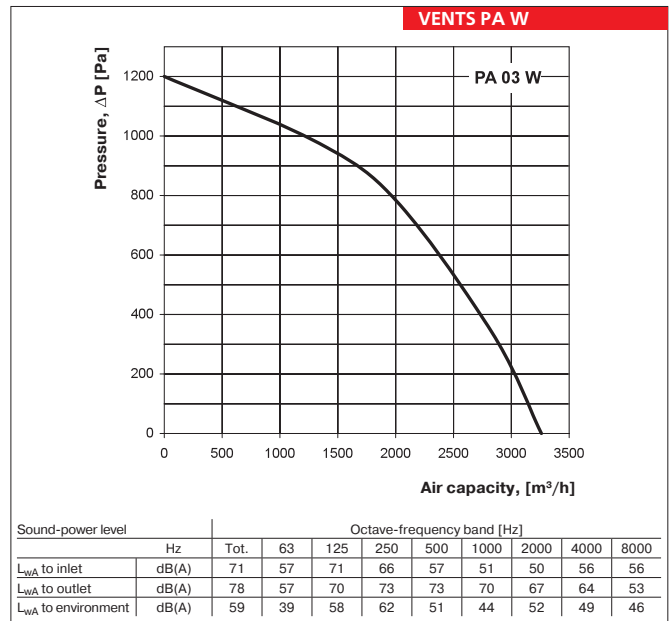
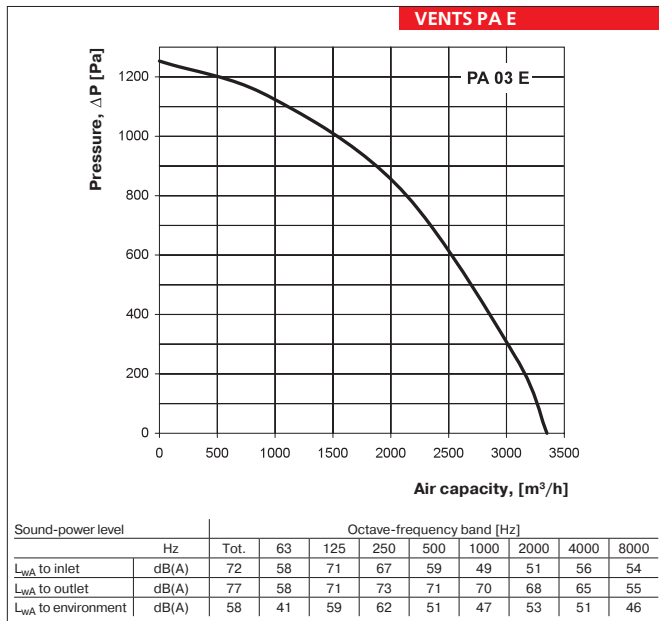

**Accessories to supply units:**

Type	G4 replaceable filter	F7 replaceable filter	Filter type
PA 01 E	SF PA/WA 01 E G4	-	panel filter
PA 02 E	SF PA/WA 02 E G4	-	panel filter
PA 03 E	SF PA/WA 03 E G4	-	panel filter
PA 01 W2	SFK PA 01 W G4	SFK PA 01 W F7	pocket filter
PA 01 W4			
PA 02 W2	SFK PA 02 W G4	SFK PA 02 W F7	pocket filter
PA 02 W4			
PA 03 W2	SFK PA 03 W G4	SFK PA 03 W F7	pocket filter
PA 03 W4			
PA 04 W2	SFK PA 04 W G4	SFK PA 04 W F7	pocket filter
PA 04 W3			

VENTS  
PA E / PA W  
SUPPLY UNIT SERIES

Hot water coil parameters:

VENTS PA W

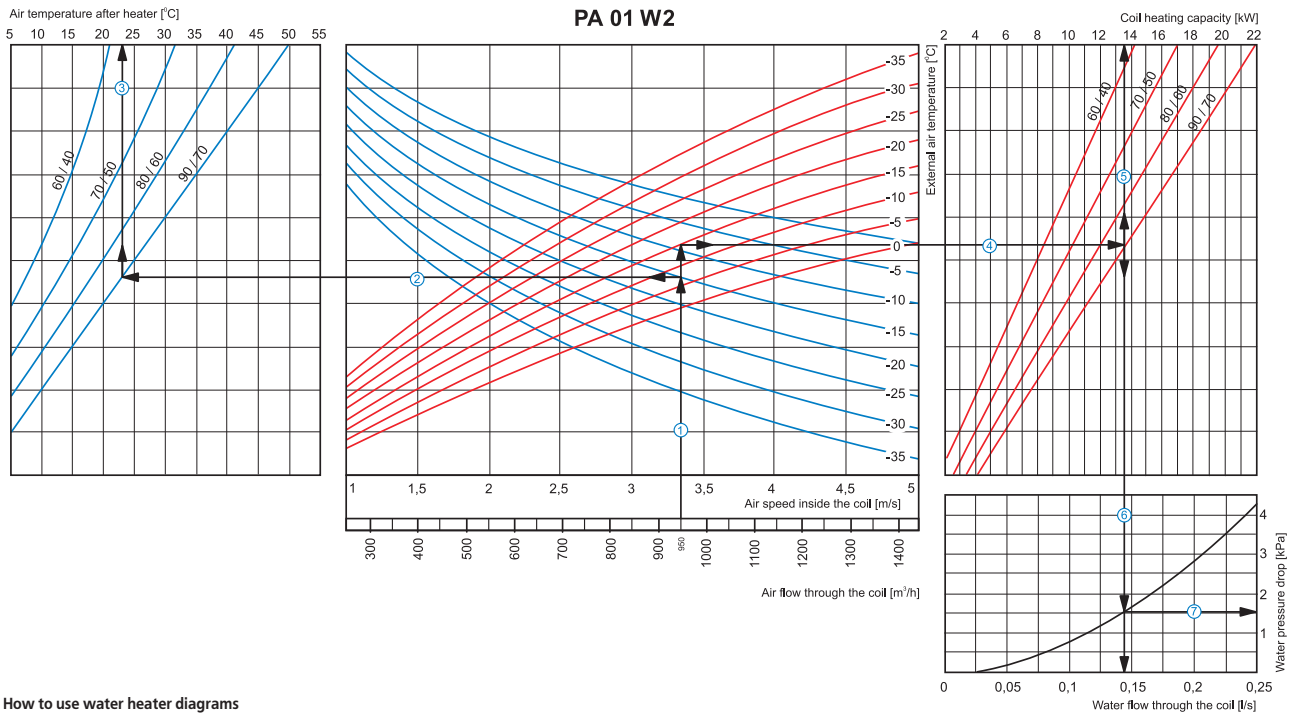

How to use water heater diagrams

System Parameters: Air flow = 950 m³/h. Outside air temperature = -15°C. Water temperature (in/out) = 90/70 °C.

- Air Speed. Starting from 950 m³/h on the air flow scale draw a vertical line ① till the air speed axis which makes about 3.35 m/s.
- Supply air temperature. Prolong the line ① up to the point where it crosses the outside air temperature (blue curve, e.g. -15°C); then draw a horizontal line ② from this point to the left till crossing water in/out temperature curve (e.g. 90/70 °C). From this point draw a vertical line ③ to the supply air temperature axis on top of the graphic (+23°C).
- Heating coil capacity. Prolong the line ① up to the point where it crosses the outside air temperature (e.g. -15°C, red curve) and draw a horizontal line ④ from this point to the right until it crosses water in/out temperature curve (90/70 °C), from here draw a vertical line ⑤ up to the scale representing the heating coil capacity (13.5 kW).
- Water flow. Prolong the line ⑤ down to water flow axis at the bottom of the graphic ⑥ (0.14 l/s).
- Water pressure drop. Draw the line ⑦ from the point where the line ⑥ crosses the black curve to the pressure drop axis. (1.5 kPa).

VENTS PA W

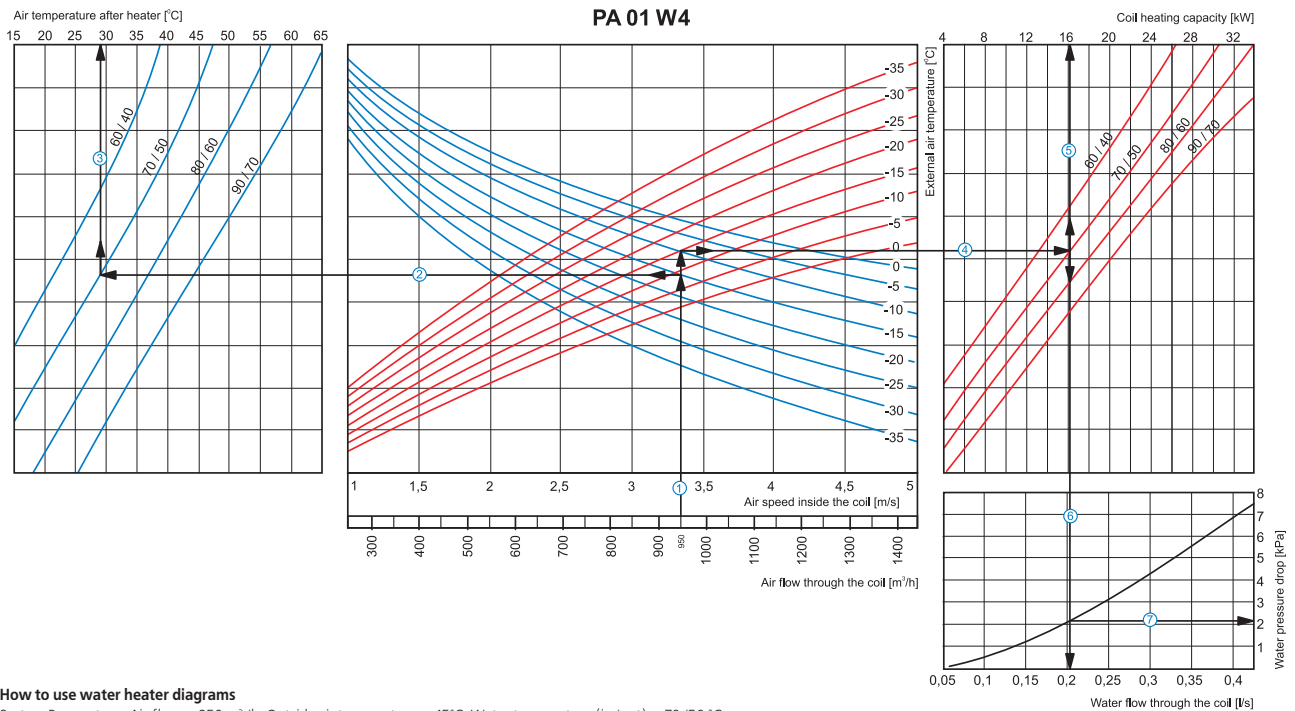

How to use water heater diagrams

System Parameters: Air flow = 950 m³/h. Outside air temperature = -15°C. Water temperature (in/out) = 70/50 °C.

- Air Speed. Starting from 950 m³/h on the air flow scale draw a vertical line ① till the air speed axis which makes about 3.35 m/s.
- Supply air temperature. Prolong the line ① up to the point where it crosses the outside air temperature (blue curve, e.g. -15°C); then draw a horizontal line ② from this point to the left till crossing water in/out temperature curve (e.g. 70/50 °C). From this point draw a vertical line ③ to the supply air temperature axis on top of the graphic (+29°C).
- Heating coil capacity. Prolong the line ① up to the point where it crosses the outside air temperature (e.g. -15°C, red curve) and draw a horizontal line ④ from this point to the right until it crosses water in/out temperature curve (e.g., 70/50 °C), from here draw a vertical line ⑤ up to the scale representing the heating coil capacity (16.0 kW).
- Water flow. Prolong the line ⑤ down to water flow axis at the bottom of the graphic ⑥ (0.2 l/s).
- Water pressure drop. Draw the line ⑦ from the point where the line ⑥ crosses the black curve to the pressure drop axis. (2.1 kPa).

**Hot water coil parameters:**

**VENTS PA W**

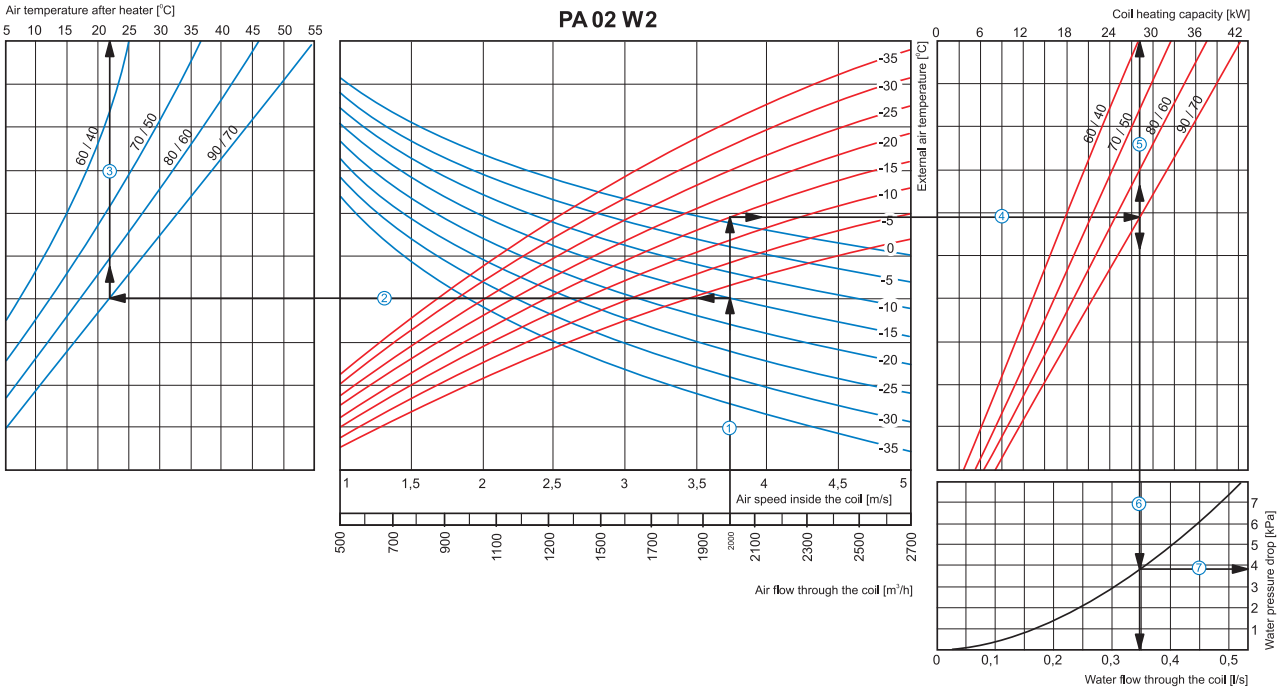

**How to use water heater diagrams**

System Parameters: Air flow = 2000 m<sup>3</sup>/h. Outside air temperature = -15°C. Water temperature (in/out) = 90/70 °C.

- Air Speed. Starting from 2000 m<sup>3</sup>/h on the air flow scale draw a vertical line ① till the air speed axis which makes about 3.75 m/s.
- Supply air temperature. Prolong the line ① up to the point where it crosses the outside air temperature (blue curve, e.g. -15°C); then draw a horizontal line ② from this point to the left till crossing water in/out temperature curve (e.g. 90/70 °C). From this point draw a vertical line ③ to the supply air temperature axis on top of the graphic (+22°C).
- Heating coil capacity. Prolong the line ① up to the point where it crosses the outside air temperature (e.g. -15°C, red curve) and draw a horizontal line ④ from this point to the right until it crosses water in/out temperature curve (e.g., 90/70 °C), from here draw a vertical line ⑤ up to the scale representing the heating coil capacity (28.0 kW).
- Water flow. Prolong the line ⑤ down to water flow axis at the bottom of the graphic ⑥ (0.35 l/s).
- Water pressure drop. Draw the line ⑦ from the point where the line ⑥ crosses the black curve to the pressure drop axis. (3.8 kPa).

**VENTS PA W**

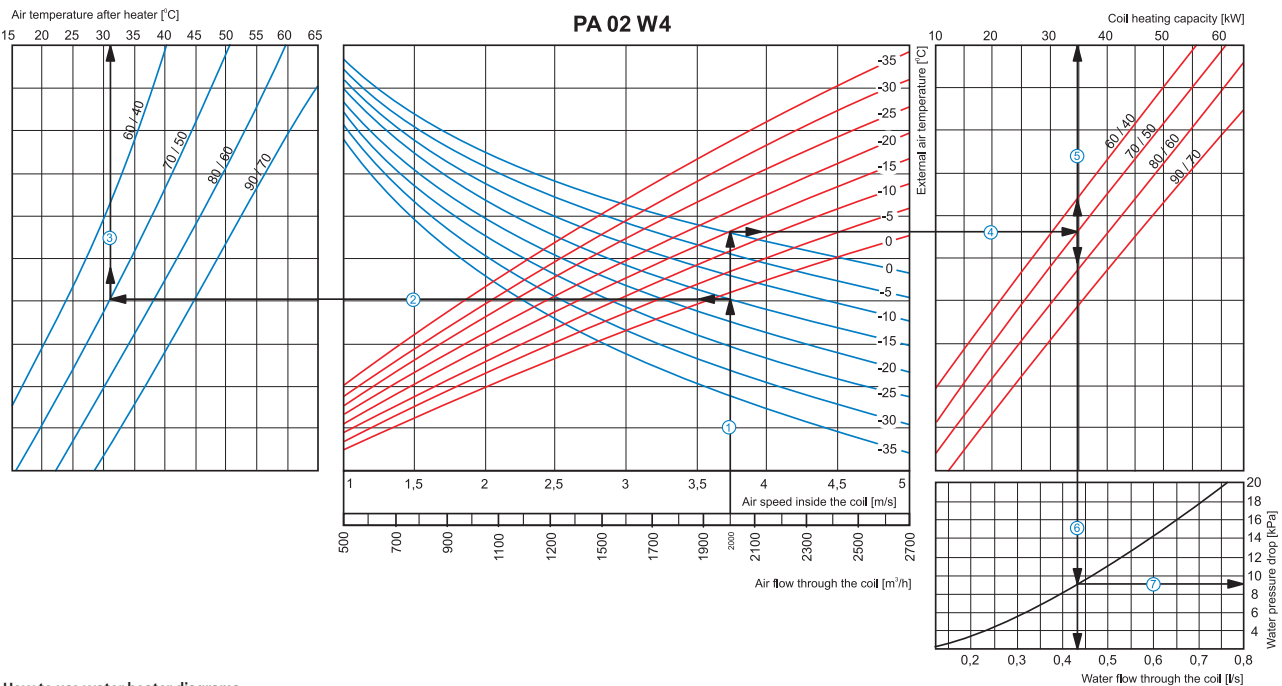

**How to use water heater diagrams**

System Parameters: Air flow = 2000 m<sup>3</sup>/h. Outside air temperature = -15°C. Water temperature (in/out) = 70/50 °C.

- Air Speed. Starting from 2000 m<sup>3</sup>/h on the air flow scale draw a vertical line ① till the air speed axis which makes about 3.75 m/s.
- Supply air temperature. Prolong the line ① up to the point where it crosses the outside air temperature (blue curve, e.g. -15°C); then draw a horizontal line ② from this point to the left till crossing water in/out temperature curve (e.g. 70/50 °C). From this point draw a vertical line ③ to the supply air temperature axis on top of the graphic (+31°C).
- Heating coil capacity. Prolong the line ① up to the point where it crosses the outside air temperature (e.g. -15°C, red curve) and draw a horizontal line ④ from this point to the right until it crosses water in/out temperature curve (e.g., 70/50 °C), from here draw a vertical line ⑤ up to the scale representing the heating coil capacity (35.0 kW).
- Water flow. Prolong the line ⑤ down to water flow axis at the bottom of the graphic ⑥ (0.43 l/s).
- Water pressure drop. Draw the line ⑦ from the point where the line ⑥ crosses the black curve to the pressure drop axis. (9.0 kPa).

VENTS  
PA E / PA W  
SUPPLY UNIT SERIES

Hot water coil parameters:

VENTS PA W

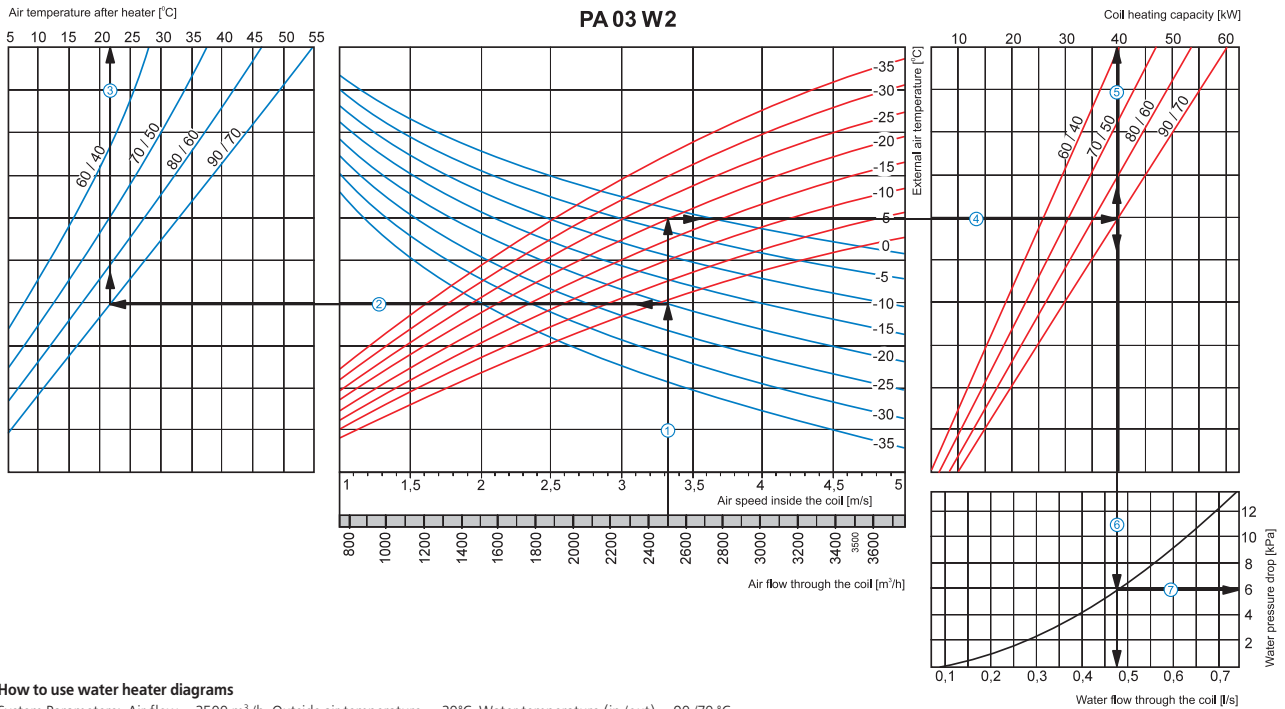

How to use water heater diagrams

System Parameters: Air flow = 2500 m<sup>3</sup>/h. Outside air temperature = -20°C. Water temperature (in/out) = 90/70 °C.

- Air Speed. Starting from 2500 m<sup>3</sup>/h on the air flow scale draw a vertical line ① till the air speed axis which makes about 3.32 m/s.
- Supply air temperature. Prolong the line ① up to the point where it crosses the outside air temperature (blue curve, e.g. -20°C); then draw a horizontal line ② from this point to the left till crossing water in/out temperature curve (e.g. 90/70 °C). From this point draw a vertical line ③ to the supply air temperature axis on top of the graphic (+22°C).
- Heating coil capacity. Prolong the line ① up to the point where it crosses the outside air temperature (e.g. -20°C, red curve) and draw a horizontal line ④ from this point to the right until it crosses water in/out temperature curve (e.g., 90/70 °C), from here draw a vertical line ⑤ up to the scale representing the heating coil capacity (40.0 kW).
- Water flow. Prolong the line ⑤ down to water flow axis at the bottom of the graphic ⑥ (0.47 l/s).
- Water pressure drop. Draw the line ⑦ from the point where the line ⑥ crosses the black curve to the pressure drop axis. (6.0 kPa).

VENTS PA W

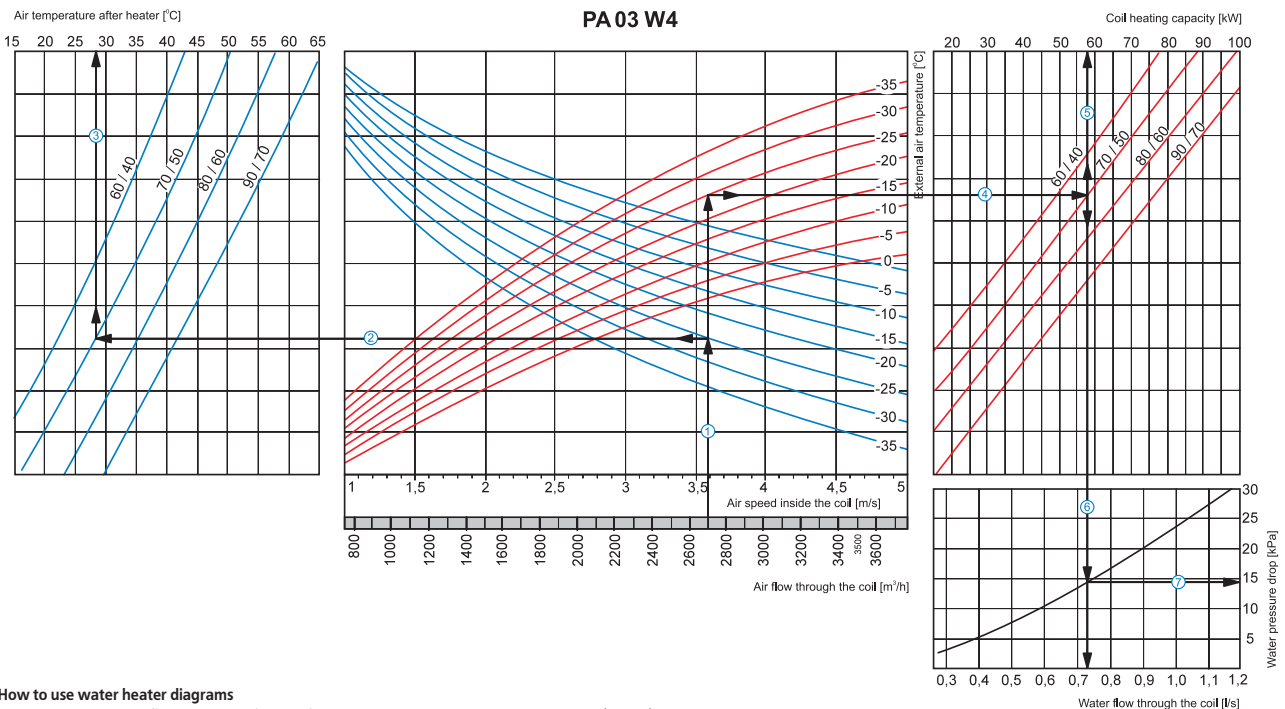

How to use water heater diagrams

System Parameters: Air flow = 2700 m<sup>3</sup>/h. Outside air temperature = -25°C. Water temperature (in/out) = 70/50 °C.

- Air Speed. Starting from 2700 m<sup>3</sup>/h on the air flow scale draw a vertical line ① till the air speed axis which makes about 3.59 m/s.
- Supply air temperature. Prolong the line ① up to the point where it crosses the outside air temperature (blue curve, e.g. -25°C); then draw a horizontal line ② from this point to the left till crossing water in/out temperature curve (e.g. 70/50 °C). From this point draw a vertical line ③ to the supply air temperature axis on top of the graphic (+28°C).
- Heating coil capacity. Prolong the line ① up to the point where it crosses the outside air temperature (e.g. -25°C, red curve) and draw a horizontal line ④ from this point to the right until it crosses water in/out temperature curve (e.g., 70/50 °C), from here draw a vertical line ⑤ up to the scale representing the heating coil capacity (58.0 kW).
- Water flow. Prolong the line ⑤ down to water flow axis at the bottom of the graphic ⑥ (0.73 l/s).
- Water pressure drop. Draw the line ⑦ from the point where the line ⑥ crosses the black curve to the pressure drop axis. (14.0 kPa).

**Hot water coil parameters:**

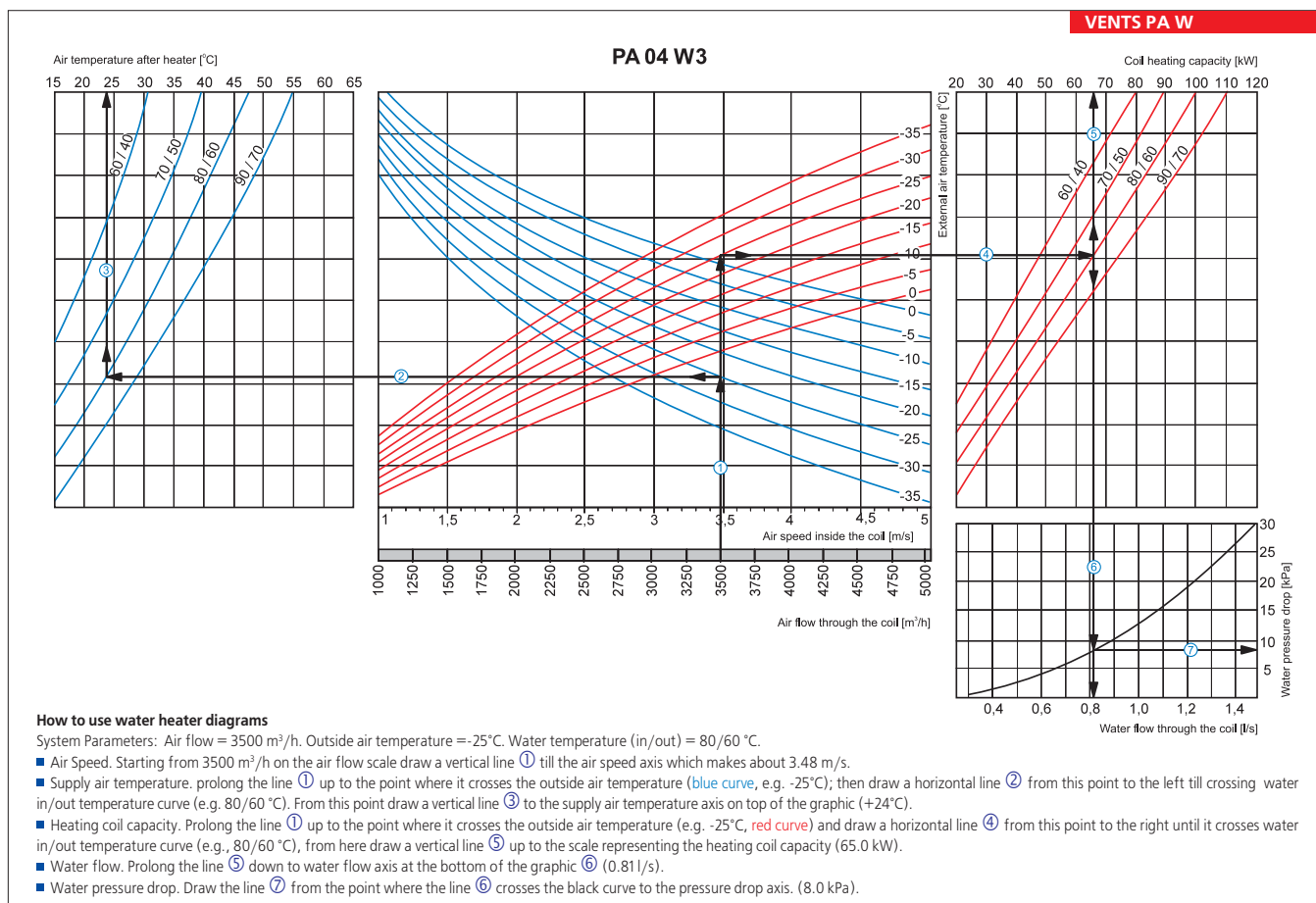
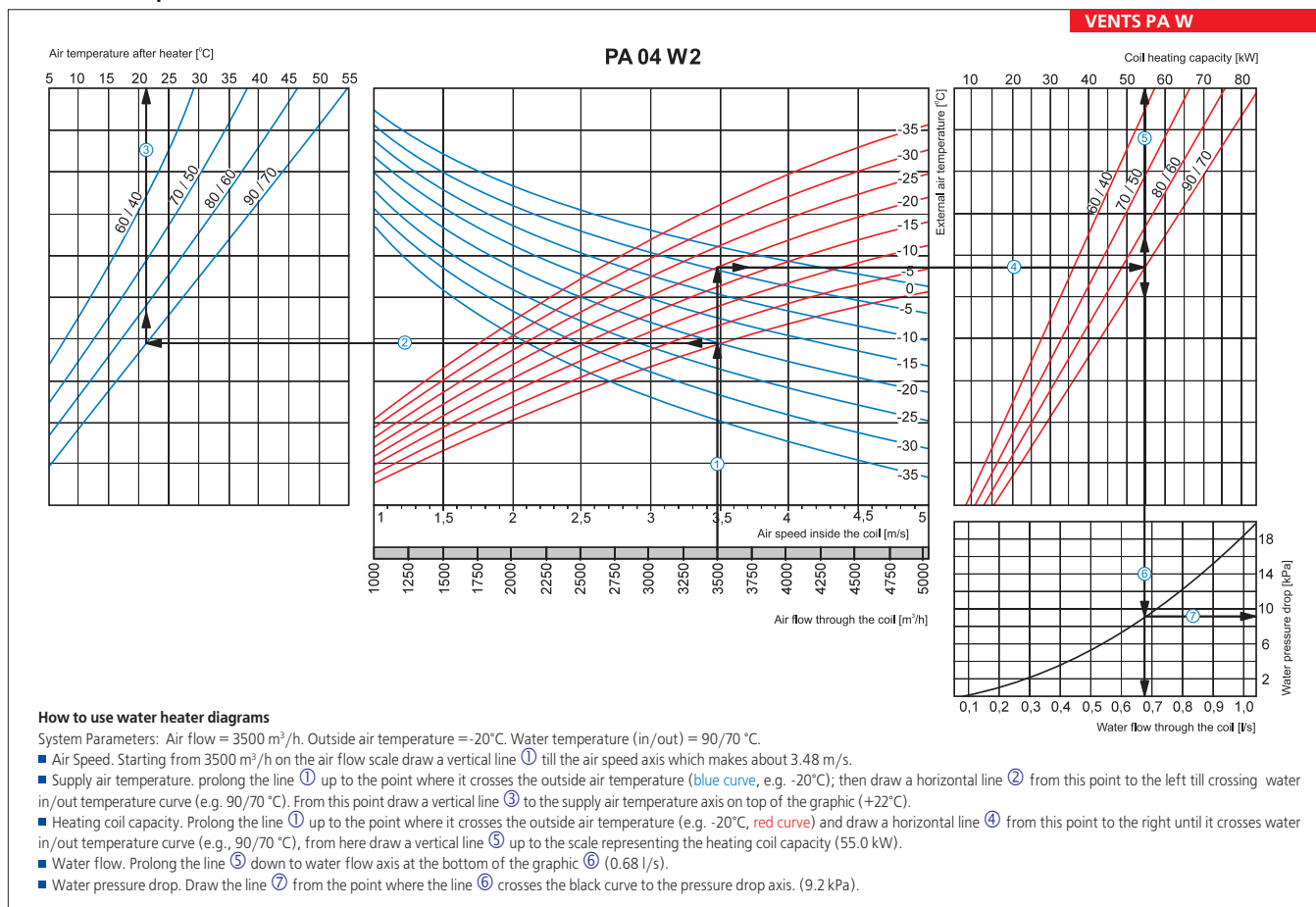

VENTS  
PA E / PA W  
SUPPLY UNIT SERIES



Series  
**VENTS VA**



Compact suspended units with the air capacity up to **4450 m<sup>3</sup>/h** in the sound-insulated casing

■ **Description**

VA exhaust unit is a complete ventilation unit designed for extract air removal from premises. Air capacity up to 4450 m<sup>3</sup>/h. To ensure balanced ventilation use VA unit together with PA unit.

■ **Casing**

The casing is made of aluminum-zinc steel plates with 50 mm thermal and sound-insulating mineral wool layer.

■ **Fan**

The unit is equipped with direct driven plug fan incorporating high pressure centrifugal impeller with backward curved blades driven by the external rotor motor. Such fan configuration ensures the best operating characteristics as air capacity, noise level and efficiency. The fan can be easily removed from the casing for inspection and cleaning.

■ **Mounting**

VA exhaust units are fitted with mounting brackets for easy installation. The exhaust units are designed either for floor mounting, ceiling mounting by means of seat angles with anti-vibration mounts or for wall mounting by means of brackets. The unit can be mounted either in service spaces or in main premises above the suspended ceiling, in the pocket or in the room. All the electrical connections are performed through the terminal block placed in the connection box. The unit air capacity can be controlled by the optional control panel.

■ **Accessories**

The unit can be equipped with the air flow regulating damper flexible connectors, air filter.

**Unit overall dimensions:**

Type	Dimensions, [mm]								
	B	B1	B2	B3	H	H1	H2	L	L1
VA 01	400	420	624	585	200	220	375	660	621
VA 02	500	520	689	646	300	320	450	665	627
VA 03	600	620	787	745	350	370	500	696	657
VA 04	700	720	888	844	400	420	546	805	766

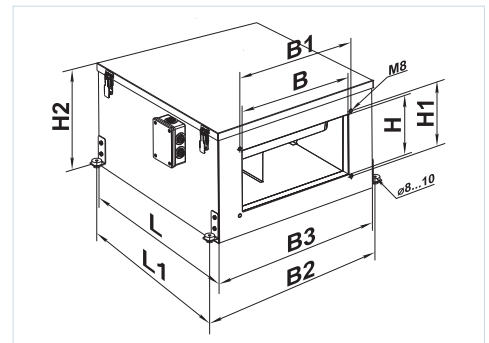

**Accessories to supply units:**

Type	Replaceable filter	Filter type
VA 01	SF PA/VA 01 E G4	panel filter
VA 02	SF PA/VA 02 E G4	panel filter
VA 03	SF PA/VA 03 E G4	panel filter
VA 04	SF VA 04 E G4	panel filter



**Designation key:**

Series	Unit standard size
<b>VENTS VA</b>	01; 02; 03; 04

**Accessories**



page 246    page 249    page 252    page 295    page 297    page 298    page 300    page 301    page 302    page 317    page 318    page 319



**Technical data:**

	VA 01	VA 02	VA 03	VA 04
Unit supply voltage [V / 50 Hz]	3~ 400	3~ 400	3~ 400	3~ 400
Maximum fan power [W]	320	620	1330	2300
Fan current [A]	0,55	1,05	2,4	4,3
Air capacity [m <sup>3</sup> /h]	1400	2700	3450	4450
RPM	2700	2690	2730	2840
Noise level at 3m [dB(A)]	51	54	57	58
Operating temperature [°C]	-25 up to +55	-25 up to +45	-25 up to +45	-25 up to +70
Casing material	aluzink	aluzink	aluzink	aluzink
Insulation	50 mm, mineral wool		50 mm, mineral wool	
Connected air duct size [mm]	400x200	500x300	600x350	700x400
Weight, [kg]	35	38	59	71

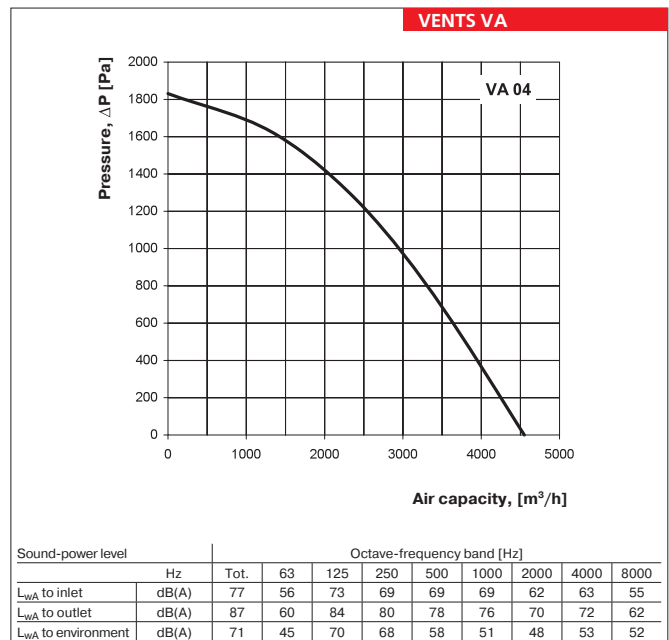
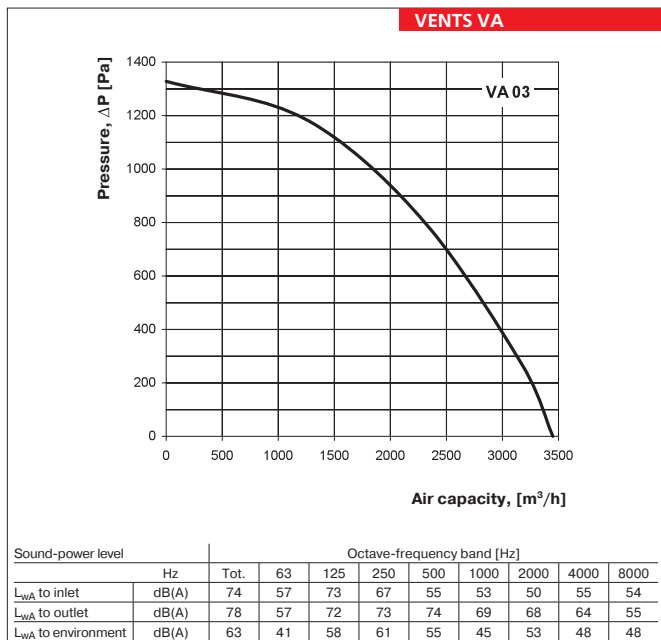
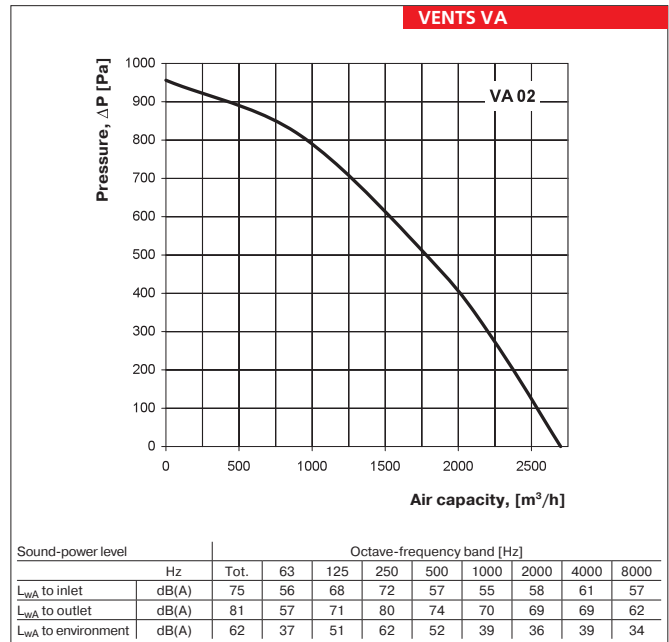
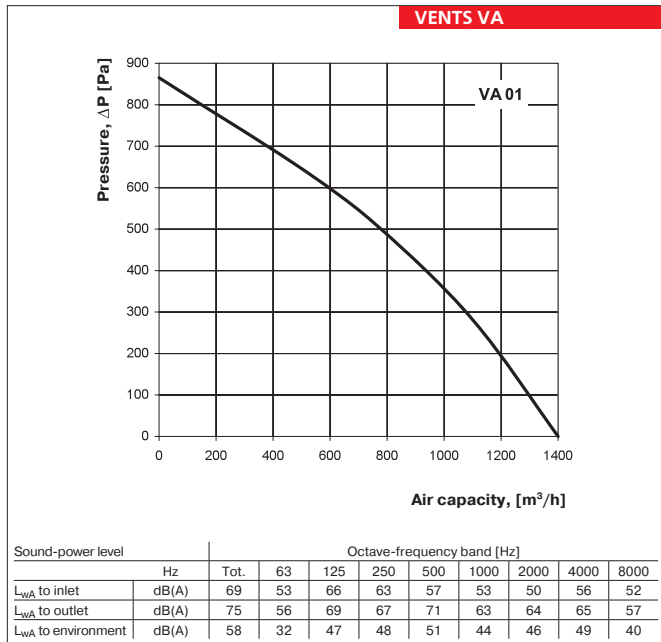

EXHAUST UNIT SERIES VENTS VA

# AIR HANDLING UNITS WITH HEAT RECOVERY

## ▶ VENTS VUT mini Series



▶ Compact sound- and heat-insulated air handling units with the air capacity up to 345 m<sup>3</sup>/h and the heat exchanger efficiency up to 85%. Designed to provide supply of fresh filtered air and extract of exhaust air from the premises. Compatible with Ø 100 and 125 mm round air ducts.

## ▶ VENTS VUT H Series



▶ Sound- and heat-insulated ventilation units with the air capacity up to 2200 m<sup>3</sup>/h and the heat exchanger efficiency up to 88%. Designed to provide supply of fresh filtered air and removal of extract air from the premises. Compatible with Ø 125, 150, 160, 200, 250, 315 mm round air ducts.

## ▶ VENTS VUT EH and VUT WH Series



▶ Sound- and heat-insulated ventilation units with the air capacity up to 2200 m<sup>3</sup>/h and the heat exchanger efficiency up to 88%. Designed to provide supply of fresh filtered air and removal of extract air from the premises. Water heating coils or electric heaters are designed for the unit operation at low outside temperatures. The units are compatible with Ø 125, 150, 160, 200, 250, 315 mm round air ducts.

## ▶ VENTS VUT PE and VENTS PV Series



▶ Compact suspended sound-proof and heat-insulated ventilation units with the air capacity up to 4000 m<sup>3</sup>/h and heat exchanger efficiency up to 90%. Designed to provide supply of fresh filtered air and removal of extract air from the premises. Water heating coils or electric heaters are designed for the unit operation at low outside temperatures. The units are compatible with 150, 160, 200, 250, 315 and 400 mm round air ducts.



**VENTS VUT mini air handling units with heat recovery**

Air capacity – up to 300 m<sup>3</sup>/h

page 188



**VENTS VUT mini with EC motor air handling units with heat recovery**

Air capacity – up to 345 m<sup>3</sup>/h

page 190



**VENTS VUT H air handling units with heat recovery**

Air capacity – up to 2200 m<sup>3</sup>/h

page 192



**VENTS VUT H with EC motor air handling units with heat recovery**

Air capacity – up to 600 m<sup>3</sup>/h

page 196



**VENTS VUT EH and VUT WH air handling units with heat recovery**

Air capacity – up to 2200 m<sup>3</sup>/h

page 198



**VENTS VUT EH and VUT WH with EC motor air handling units with heat recovery**

Air capacity – up to 600 m<sup>3</sup>/h

page 204



**VUT PE and VUT PV with EC motor air handling units with heat recovery**

Air capacity – up to 4000 m<sup>3</sup>/h

page 210

### Automation and control:

▶ VENTS air handling units supplied with incorporated automation system with control board.

Interface control board has multifunctional buttons, failure and emergency indicator. The standard set includes multifunctional control panel with graphic LCD indicator.

Functions:

- ▶ Maintaining supply air temperature
- ▶ Maintaining set air temperature level in the premises
- ▶ Ventilation rate control
- ▶ Heat recovery by means of the plate heat exchanger
- ▶ Plate heat exchanger freezing protection
- ▶ Electric heater overheating protection
- ▶ Program of correct emergency shutdown of the air heaters
- ▶ Supply air filter clogging indication
- ▶ Setting unit operation mode
- ▶ Setting week operation program with ventilation rate control
- ▶ Daily timer
- ▶ Seasonal operation mode setting
- ▶ Filter replacement timer
- ▶ Automatic detection of connected devices
- ▶ Failure indication by means of text and light alarm messages
- ▶ Failure light alarm indication
- ▶ Interface language option

### Filter

▶ High degree of air purification is achieved due to G4-F7 incorporated panel type filters on metal frames. Filter size match the European Norms and Standards. Filter clogging control by means of build-in automation system as well as filter easy removal and cleaning ensure their quality and durability.

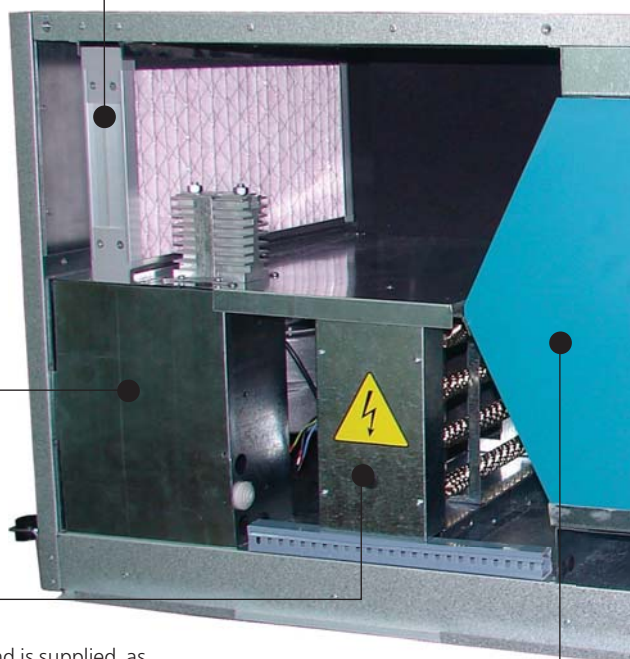

### Heater:

▶ Electric heater is designed for air handling unit operation at low outside temperature and is supplied as a standard.

▶ Electric heater is made of heat-resisting stainless steel ribbed to increase the heat exchange surface area and equipped with two overheating protecting thermostats.

### Heat exchanger (recuperator)

▶ Plate heat exchanger with a great surface area and high efficiency made of polystyrene. The extract air transfers heat to the plates and the plates transfer heat to supply air flow. The heat exchange efficiency is up to 95% which allows reducing heating costs. The supply and extract air flows do not get mixed which ensures no contamination, odours, microbes transfer. By-pass damper provides switching to no heat recovery mode if required.

Heat recovery



Control system



Effective insulation





**Photo:  
VUT 600 EH EC**

**Casing**

▶ The casing is manufactured from two-layers aluminum-zinc compound internally filled with the mineral wool layer for heat and sound insulation. The internal sheet is made of aluminum-zinc steel plates with varnish coating to ensure long service life. The internal galvanized steel plate provides the surface hygienic purity of the unit and disables dirt accumulation on the panel. The side panels can be easily removed for inspection and service of all the unit elements.

**Fan with EC motor:**



- ▶ Air supply and exhaust is effected by means of two centrifugal single-inlet EC fans equipped with backward curved blades.
- ▶ EC motor is a synchronous brushless electronically commutated motor. EC motors have energy consumption by up to 50% less as compared to standard motors of the same capacity. The operating costs for their maintenance are by 30% less.
- ▶ Such fan design ensures minimum noise level combined with high capacity.

**Anti-vibration rubber mount:**

▶ Mounting the unit onto the rubber anti-vibration mounts makes its operation totally quiet and vibration-free and disables vibration transfer to buildings.

**Drain pan:**

▶ The unit is equipped with the drain pan of painted steel for condensate collection. Draining pipes for condensate drainage on the bottom are connected to the draining system.

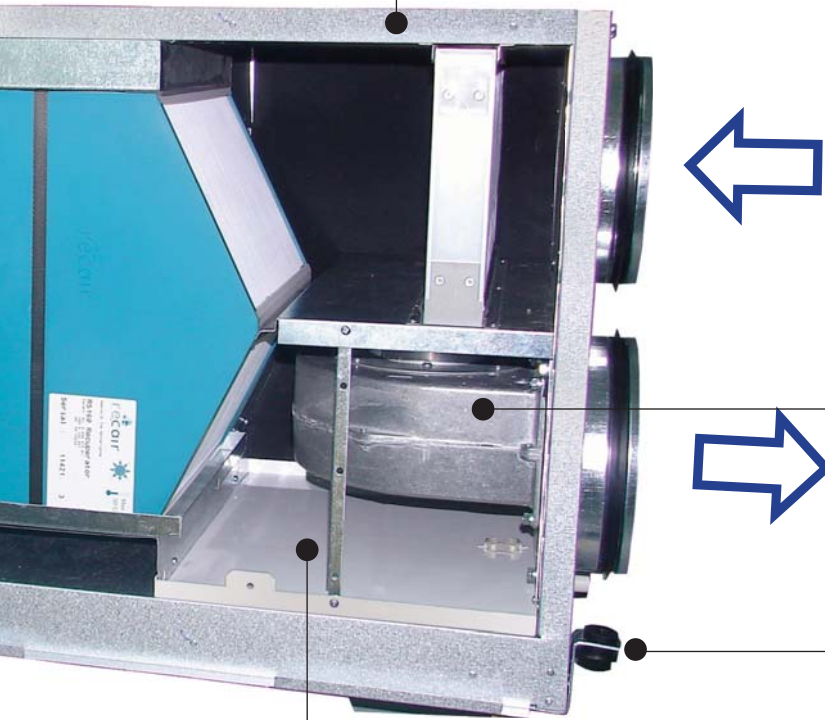

Easy mounting



Energy-saving EC motors



Easy maintenance

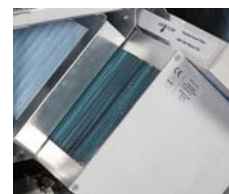

The issue of ventilation from the point of view of thermal energy saving (maintaining permanent temperature) is the most essential subject. The factors that influence the heat loss dynamics vary from wall thermal protection to heaters and heating system quality, density of wall panels joints and window joints as well as personal consumption habits.

In modern buildings ventilation demands up to 45% of the total heat energy consumption. The reasons are as follows:

- a) One half of air volume is exchanged through the open window within 30-60 min. During this process the heat losses grow tremendously;
- b) Energy saving houses are equipped with all available facilities for sealing and thermal isolation of the buildings. Such houses are so well insulated that the heat loss through the walls makes only 30 to 40% of the total amount.

Thus the heat losses caused by ventilation process remove 2/3 of the total heat. So we come to the point of providing air exchange with minimum heat losses. From 30% to 70% of heat loss is variously estimated for the traditional for residential houses exhaust ventilation. Controllable air exchange and heat recovery are the compulsory attributes in the modern construction that are ensured by means of air handling units. The forced ventilation allows recuperating up to 90% of the exhaust air heat. Such effect is attained due to installation of the heat exchanger (recuperator).

The heat exchanger allows saving heat in winter period and contributes to better operation of air conditioners jointly with ventilation system in summer period. In addition the heat exchangers have heat- and soundinsulated casing that reduces the noise level produced by equipment in the room. As of today the ventilation systems based on heat exchangers are the most state-of-the-art and progressive solution for air exchange arranging in the premises.

Due to recuperation of the unit its owner can save good money for operation costs. Use of the ventilation units with heat recovery jointly with the air conditioning systems is not only the most effective way to arrange the required microclimate in the room but to cut costs as well. In winter the heat exchanger saves heat and in summer it saves cool.

Controllable air exchange and thermal energy recovery are the the must-have components in a modern house. Air handling units are the best solution for these targets. Forced ventilation allows recuperating up to 90% of extract air heat energy. This function is possible due to the heat exchanger (recuperator).

The plate heat exchanger of cross-flow or countercurrent type is the simplest one and contains no movable parts and electrical connections; it separates the air streams fully; maintenance-free and requires no additional energy consumption. Utilization of units with heat recovery in ventilation systems results in shortening of payback period and improving its ecological characteristics in view of low energy demand, low investment for heat energy generation and its distribution, careful attitude to environment.

New series of compact air handling units with EC (electronically commutated) motors provide energy consumption reducing up to 50% as compared to traditional asynchronous motors. Operating costs will be by 30% in general reduced.

Fans with EC motors have the following advantages:

- ▶ efficient operation at any rotation speed of fan impeller (up to zero) and significant winding electrical resistance;
- ▶ low heat generation that enables reducing performance losses of refrigeration equipment and compensate for heat generation of fan motors in case of utilization of EC-motor fans in conditioning systems;
- ▶ fan overall dimensions can be reduced in case of the design with external rotor and EC-motor advantages. Consequently the disadvantages related to large-scale overall dimensions that are typical for fans with standard motors are minimized;
- ▶ the maximum motor speed does not depend upon frequency (operation both at 50 Hz and 60 Hz is possible);
- ▶ high efficiency at low speed;
- ▶ design with external rotor to make it compact.

The plate heat exchanger of cross-flow or duct counter-flow type are used for heat recovery in ventilation units Vents VUT. The exhaust air in the heat exchanger transfers the heat energy to the supply air.

### Structure and operating principle of the plate heat exchangers

The design of the plate heat exchangers is such as to exclude the transfer of contaminants, odours and microbes from the exhaust air flow to the supply air flow as both warm (exhaust) and cold (supply) air flows are divided by wall elements of heat exchanger plates made of aluminium or polystyrene. Thermal energy quantity that is transferred from the exhaust air to the supply air depends exclusively on the thermal conductivity of the applied materials and temperature difference between two flows. Concurrently the warm exhaust air is heated and the cold supply air is cooled.

Though there is no moisture exchange between the extract and supply air streams,

a part of latent wet extract air energy is used for heat recovery. In case of low outside temperature and high extract air temperature the exhaust air temperature can drop down to dew point. Thus condensate is generated and the latent evaporation heat is released. During condensate generation the temperature difference between the warm and cold air streams in the heat exchanger is higher as compared to the process with no condensate. Thus that means higher heat energy extraction and higher heat recovery efficiency.

For that reason free condensate drainage shall be provided.

Use of plate heat exchangers in ventilation system results in shorter payback



period and better ecological characteristics ensuring the further advantages:

- ▶ low energy consumption;
- ▶ low investment for thermal energy generation and its distribution;
- ▶ no removable parts which means durability and long service life at continuous operation;
- ▶ high-efficient heat recovery and little investment result in high self-repayment;
- ▶ environmental protection.



Operating principle of plate heat recovery of cross-flow type

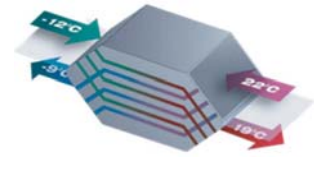

Operating principle of plate heat recovery of counter-flow type

### Design and operating principle of air handling units based on VUT-600 WH EC example.

VUT-600 WH EC unit operates as follows:

Fresh cold air from outside is supplied to VUT WH EC unit through the air ducts, gets filtered and passes further through the heat exchanger from where it is supplied to premises by means of the supply fan. Warm exhaust air from premises goes back to VUT WH EC unit through the ducts where it gets filtered, then passes again through the heat exchanger and is exhausted outside by means of the exhaust fan. The exchange of heat energy of the warm contaminated air from the premises with the fresh cold air from outside takes place in the heat exchanger. That reduces heat losses and consequently cuts the heating costs in winter time.

That reduces heat losses and consequently cuts the heating costs in winter time.

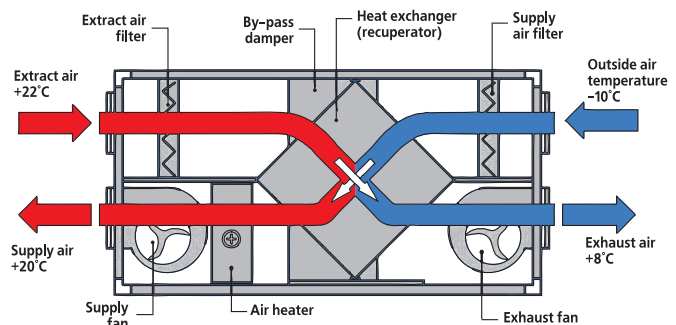

### Recuperation economic analysis:

Air capacity: 500 m<sup>3</sup>/h

t<sub>1</sub> – temperature after heat exchanger;

t<sub>2</sub> – intake (-10 °C);

t<sub>3</sub> – indoor temperature (+22 °C).

Recuperation efficiency is calculated as follows: K<sub>ef</sub> = 60%

Supply air temperature after heat exchanger:

$$t_1 = t_2 + K_{ef}(t_3 - t_2) = (-10) + 0,60(22 - (-10)) = 9,2 \text{ °C}$$

To heat the air temperature up to the temperature 19,2 °C

the following energy consumption is required:

$$P(Wt) = L(m^3/h) \times 0,34 \times t(°C) = \\ = 500 \text{ m}^3/h \times 0,34 \times 19,2 = 3264 \text{ W}$$

### Marking of VENTS VUT models.

The following abbreviations for VUT units marking:

heater type (if provided in the model):

**E** - electric heater

**W** - water (glycol) heating coils

Design:

**H** - horizontal duct connection (ducts at both sides)

**V** - vertical duct connection (ducts upwards)

**P** - ceiling suspended

**mini** - units with the maximum air capacity up to 300 m<sup>3</sup>/h, easy control system and minimized overall dimensions.

Motor type:

**No designation** - AC motors.

**EC** - electronically commutated motors (EC motors)

Example:

**VUT 600 EH EC**

Ventilation unit with Heat Recovery, air capacity up to 600 m<sup>3</sup>/h equipped with **Electric Heater** that has horizontal duct connection and fan powered by **EC**-motor.

Series  
**VENTS VUT V mini**



Speed controller RS-1-400

Air handling units with the air capacity up to **300 m<sup>3</sup>/h** in the compact sound- and heat-insulated casing with vertical duct connections

Series  
**VENTS VUT H mini**



Speed controller RS-1-400

Air handling units with the air capacity up to **300 m<sup>3</sup>/h** in the compact sound- and heat-insulated casing with horizontal duct connections

■ **Description**

VUT air handling units mini are the complete ventilation units designed for air filtration, heating and supply to the premises and removal of exhaust air. The heat of the exhausted air is transferred to the supply air through the plate heat exchanger. All the models are compatible with 100 and 125 mm round ducts.

■ **Modifications**

**VUT V mini** – the models with vertical duct connections, fans with AC motors.

**VUT H mini** – the models with horizontal duct connections, fans with AC motors.

■ **Casing**

The casing is made of aluzink with 20 mm mineral wool internal heat and sound insulation.

■ **Filter**

Two G4 built-in filters ensure supply and exhaust air filtration.

■ **Fans**

The unit is equipped with supply and exhaust centrifugal fans with backward curved blades and built-in thermal overheating protection with automatic restart. The electric motors and the impellers are dynamically balanced in two planes.

■ **Heat exchanger**

The plate heat exchanger is made of aluminium plates. Whenever heat recovery is not required for unit operation the heat exchanger block can be easily replaced by a "summer" block. The unit is also equipped with the drain pan for condensate drainage as well as with built-in icing protecting system. During operation of the heat exchanger in the winter time the heat from the warm exhaust air is transferred to the cold supply air. During extract air heat energy extraction some condensate can be generated. If the temperature of the intake air is below -5°C the condensate can get frozen. To prevent the heat exchanger freezing electronic protection system is applied. It switches the supply fan off as

the temperature sensor requires. Warm extract air defrosts the heat exchanger, then the supply fan switches on and the unit continues operating under rated conditions.

■ **Control**

Switching the unit on and its capacity control is performed with thyristor speed controller (PC-1-400) which provides smooth motor speed control over the range of 0-100%.

■ **Mounting**

Air handling unit is mounted on the floor and suspended to the ceiling by means of a seat angle with inserted vibration-damping element or attached to a wall with brackets. The unit can be mounted either in service spaces or in main premises above the suspended ceiling, in the pocket or the unit can be placed directly in the room. Mounting position shall provide correct condensate drainage. Access for maintenance and filter cleaning shall be reserved on the side of the removable side panel.

**Designation key:** \_\_\_\_\_

Series <b>VENTS VUT</b>	Rated air capacity, m <sup>3</sup> /h 200; 300	Duct connection <b>V</b> – vertical duct connection <b>H</b> – horizontal duct connection	Type <b>mini</b>
----------------------------	--	---	---------------------

**Accessories**



page 240   page 240   page 294   page 296   page 305   page 310   page 310   page 311

**Offered options to the units**



page 189   page 189

**Technical data:**

	VUT 200 H mini	VUT 200 V mini	VUT 300 H mini	VUT 300 V mini
Unit supply voltage [V / 50 Hz]	1~ 230		1~ 230	
Maximum fan power [W]	2pcs. x 58		2pcs. x 58	
Fan current [A]	2pcs. x 0,26		2pcs. x 0,26	
Total power of the unit [W]	116		116	
Total current of the unit [A]	0,52		0,52	
Air capacity [m³/h]	200		300	
RPM	2500		2500	
Noise level at 3m [dB[A]]	24-45		28-47	
Operating temperature [°C]	-25 up to +50		-25 up to +50	
Casing material	aluzink		aluzink	
Insulation	20 mm mineral wool		20 mm mineral wool	
Filter: exhaust / supply	panel filter G4		panel filter G4	
Replaceable filter*	SF VUT mini G4		SF VUT mini G4	
Summer block*	VL VUT mini		VL VUT mini	
Duct connection diameter, [mm]	∅ 100		∅ 125	
Weight, [kg]	30		30	
Recuperation efficiency	up to 85%		up to 85%	
Heat exchanger type	cross-flow type		cross-flow type	
Heat exchanger material	aluminum		aluminum	

\*option

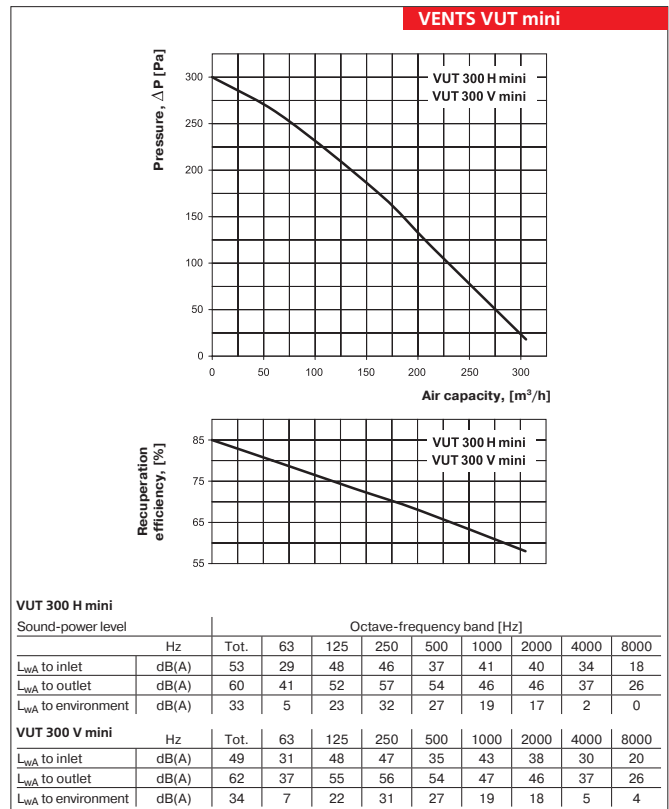
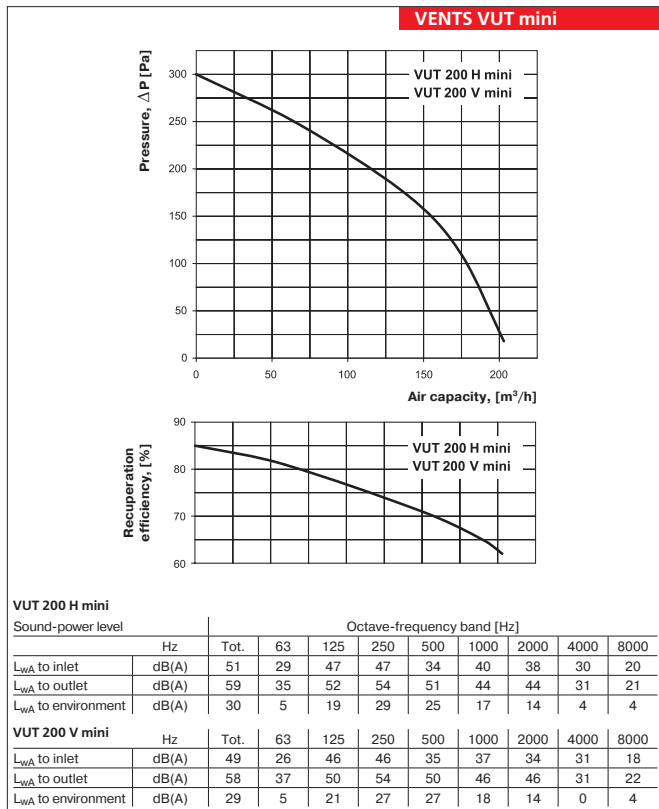

**Unit overall dimensions:**

Type	Dimensions, [mm]											
	∅D	B	B1	B2	B3	H	H1	H2	H3	L	L1	L2
VUT 200 H mini	99	278	200	121	192	481	431	84	191	699	640	600
VUT 300 H mini	124	278	200	139	139	481	431	89	296	699	640	600

Type	Dimensions, [mm]												
	∅D	B	B1	B2	B3	H	H1	L1	L2	L3	L4	L5	L6
VUT 200 V mini	99	278	200	109	169	481	431	640	600	73,5	204	396	526,5
VUT 300 V mini	124	278	200	100	178	481	431	640	600	74	210	390	526

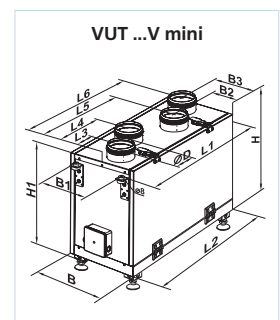
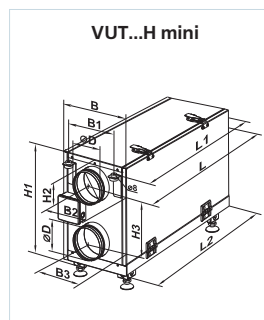

VENTS  
 AIR HANDLING UNIT WITH  
 HEAT RECOVERY SERIES  
 VUT mini

Series  
**VENTS VUT V mini EC**



Speed controller R-1/010



Series  
**VENTS VUT H mini EC**



Speed controller R-1/010



with the high efficiency and perfect control over the whole speed range. Premium efficiency (reaching 90%) is an absolute advantage of electronically commutated motors.

■ **Heat exchanger**

The cross-flow air-to-air plate heat exchanger block is manufactured from aluminum plates. Whenever heat recovery is not required the heat exchanger block can be easily replaced by a "summer" block. The unit is also equipped with the drain pan for condensate drainage as well as built-in icing protecting system. Its operating principle is based on switching the supply fan off as the temperature sensor requires. Warm exhaust air heats the heat exchanger. Then the supply fan switches on and the unit continues operating under normal rated conditions.

■ **Control**

The unit is controlled by means of external control signal 0-10 V (e.g., R-1/010 controller for EC-motors). Air capacity as a function of temperature level, pressure and smoke conditions and other system parameters. Should the value of the control parameter get changed the EC-motor changes its speed and the fan boosts as much air flow to the ventilation system as required.

■ **Mounting**

Air handling unit is mounted on the floor and suspended to the ceiling by means of a seat angle with inserted vibration-damping element or attached to a wall with brackets. The unit can be mounted either in service spaces as balcony, storeroom, basement, roof space or in main premises above the suspended ceiling, in the pocket or the unit can be placed directly in the room. Mounting in any position shall provide correct condensate drainage. Access for the maintenance shall be reserved at the side of the swing-out access door.

Air handling units with the air capacity up to **345 m<sup>3</sup>/h** and the recuperation efficiency up to 85% in the compact sound- and heat-insulated casing with vertical duct connections.

Air handling units with the air capacity up to **345 m<sup>3</sup>/h** and the recuperation efficiency up to 85% in the compact sound- and heat-insulated casing with horizontal duct connections.

■ **Description**

VUT mini air handling unit is a complete air handling unit designed for air filtration, heating and supply to the premises and removal of exhaust air. During the operating process the heat of the exhausted air is transferred to the supply air through the plate heat exchanger. Applied in ventilation and conditioning systems for various premises that require economic solution and controllable air exchange. EC-motors reduce energy consumption by 1.5-3 times and ensure high efficiency and low noise level at the same time. All the models are compatible with Ø 100 and 125 mm round ducts.

■ **Modifications**

VUT V mini EC series are energy saving Air Handling Units (AHU) equipped with intake and exhaust centrifugal fans powered by EC motors, cross-flow heat recovery elements and air filters. Vertical duct connections.  
VUT H mini EC series are energy saving Air Handling

Units (AHU) equipped with supply and exhaust centrifugal fans powered by EC motors, cross-flow heat recovery elements and air filters. Horizontal duct connections.

■ **Casing**

The casing is manufactured from aluminum-zinc compound with 20 mm thick mineral wool layer for heat and sound insulation.

■ **Filter**

Two incorporated G4 panel filters for intake and supply air filtration are applied in the unit.

■ **Motor**

The impeller with backward curved blades is powered by high-efficient electronically commutated (EC) direct current motor. As of today the ventilation system based on heat exchangers is the most state-of-the-art and progressive solution for air exchange organization in the premises. EC motors are featured

**Designation key:**

Series	Rated air capacity, m <sup>3</sup> /h	Duct connection	Type	Motor type
<b>VENTS VUT</b>	200; 300	<b>V</b> – vertical <b>H</b> – horizontal	<b>mini</b>	<b>EC</b> – electronically commutated synchronous motor

**Accessories**



page 240    page 240    page 294    page 296    page 305    page 324

**Offered options to the units**

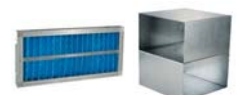

page 191    page 191

**Technical data:**

	VUT 200 H mini EC	VUT 200 V mini EC	VUT 300 H mini EC	VUT 300 V mini EC
Unit supply voltage [V / 50 Hz]	1~ 230		1~ 230	
Maximum fan power [W]	2pcs. x 105		2pcs. x 105	
Fan current [A]	2pcs. x 0,9		2pcs. x 0,9	
Total power of the unit [W]	210		210	
Total current of the unit [A]	1,80		1,80	
Air capacity [m³/h]	240		345	
RPM	3550		3570	
Noise level at 3m [dB(A)]	24-45		28-47	
Operating temperature [°C]	-25 up to +60		-25 up to +60	
Casing material	aluzink		aluzink	
Insulation	20 mm mineral wool		20 mm mineral wool	
Filter: exhaust / supply	panel filter G4		panel filter G4	
Replaceable filter*	SF VUT mini G4		SF VUT mini G4	
Summer block*	VL VUT mini		VL VUT mini	
Duct connection diameter, [mm]	∅ 100		∅ 125	
Weight, [kg]	30		30	
Recuperation efficiency	up to 85%		up to 85%	
Heat exchanger type	cross-flow type		cross-flow type	
Heat exchanger material	aluminum		aluminum	

\*additional sets of replaceable filters and summer blocks are accessories and supplied separately

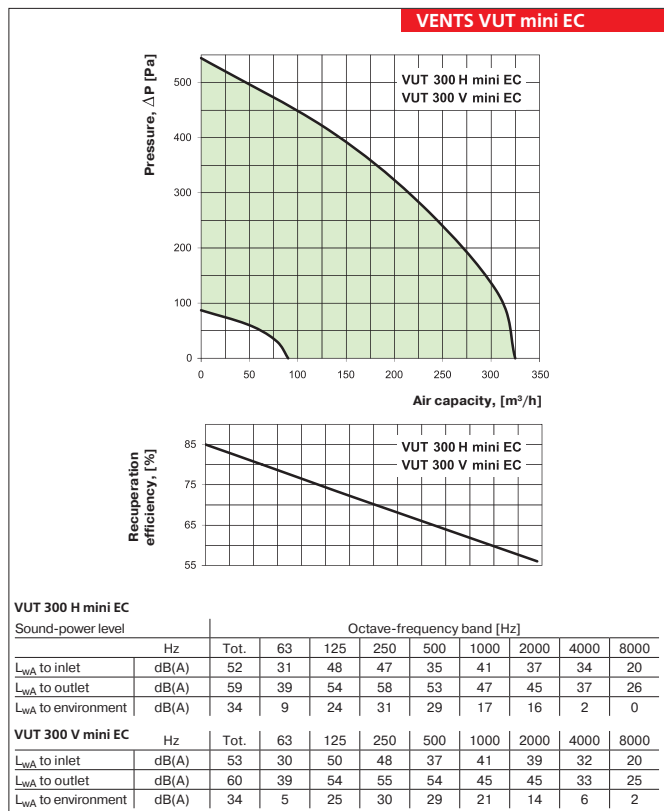
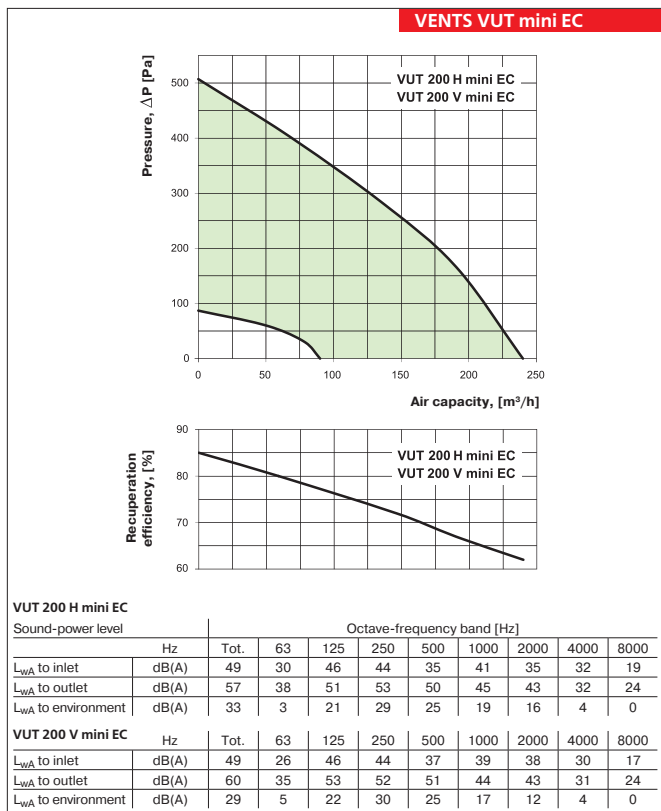

**Unit overall dimensions:**

Type	Dimensions, [mm]											
	∅D	B	B1	B2	B3	H	H1	H2	H3	L	L1	L2
VUT 200 H mini EC	99	278	200	121	192	481	431	84	191	699	640	600
VUT 300 H mini EC	124	278	200	139	139	481	431	89	296	699	640	600

Type	Dimensions, [mm]												
	∅D	B	B1	B2	B3	H	H1	L1	L2	L3	L4	L5	L6
VUT 200 V mini EC	99	278	200	109	169	481	431	640	600	73,5	204	396	526,5
VUT 300 V mini EC	124	278	200	100	178	481	431	640	600	74	210	390	526

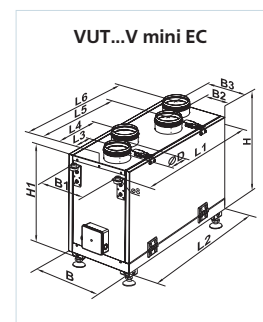
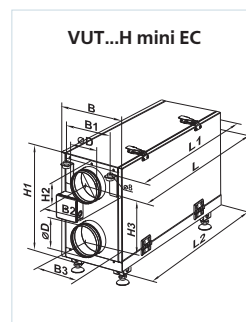

VENTS  
 AIR HANDLING UNIT WITH  
 HEAT RECOVERY SERIES  
 VUT mini EC



Series  
**VENTS VUT H**



Speed controller P3-1-300

Air handling units with the air capacity up to **2200 m<sup>3</sup>/h** and the recuperation efficiency up to **88%** in the compact sound- and heat-insulated casing.

■ **Description**

Air handling unit VUT H is a complete ventilation units designed for air filtration and supply to the premises and exhaust air removal. During the operation process the extract air heat is transferred to the supply air through the plate heat exchanger. All the models are designed for connection with Ø 125, 150, 160, 200, 250, 315 mm round ducts.

■ **Casing**

The casing is made of aluminium profile, double skinned with 20 mm mineral wool heat-and sound-insulating layer.

■ **Filter**

Two incorporated G4 panel filters for extract air ventilation and F7 filters for supply air ventilation are supplied with the unit.

■ **Fans**

The unit is equipped with supply and exhaust centrifugal double-inlet fans with forward curved blades and built-in thermal overheating protection with automatic restart. The electric motors and impellers are dynamically balanced in two planes. The ball-bearings used with motors are designed for at least 40 000 hours operation and are maintenance-free.

■ **Heat exchanger**

The cross-flow air-to-air heat exchanger block is manufactured from aluminum plates. Whenever heat recovery is not required the heat exchanger block can be easily replaced by a "summer" block. The unit is also equipped with the drain pan for condensate water drainage as well as built-in freezing protection system. Its operating principle is based on switching the supply fan off as the temperature sensor requires. Warm extract air heats the heat exchanger. Then the supply fan switches on and the unit continues operating under rated conditions.

■ **Control**

The motor speed is controlled by means of 4-step control switch by means of selecting the minimum, average or maximum speed or the unit shutdown.

■ **Mounting**

Air handling unit is mounted on the floor and suspended to the ceiling by means of a seat angle with anti-vibration mounts or attached to a wall with brackets. The unit can be mounted either in service spaces or in main premises above the suspended ceiling, in the pocket or can be placed directly in the room. Mounting in any position shall provide correct condensate drainage. Access for the fan maintenance and filter cleaning shall be provided from outside of the side panels.

**Accessories to air handling units:**

Type	G4 replaceable filter	F7 replaceable filter	Summer block
VUT 350 H	SF VUT 350-600 H G4	SF VUT 350-600 H F7	VL VUT 350 H
VUT 500 H			VL VUT 500-600 H
VUT 530 H			VL VUT 500-600 H
VUT 600 H			VL VUT 500-600 H
VUT 1000 H	SF VUT 1000 H G4	SF VUT 1000 H F7	VL VUT 1000 H
VUT 2000 H	SF VUT 2000 H G4	SF VUT 2000 H F7	VL VUT 2000 H

**Designation key:**

Series <b>VENTS VUT</b>	Rated air capacity, m <sup>3</sup> /h 350; 500; 530; 600; 1000; 2000	Duct connection <b>H</b> – horizontal
----------------------------	---	--

**Accessories**



page 240   page 240   page 294   page 296   page 305   page 323   page 325

**Offered options to the units**



page 192   page 192



**Technical data:**

	VUT 350 H	VUT 500 H	VUT 530 H
Unit supply voltage [V / 50 Hz]	1~ 230	1~ 230	1~ 230
Maximum fan power [W]	2pcs. x 130	2pcs. x 150	2pcs. x 150
Fan current [A]	2pcs. x 0,60	2pcs. x 0,66	2pcs. x 0,66
Total power of the unit [W]	260	300	300
Total current of the unit [A]	1,2	1,32	1,32
Air capacity [m <sup>3</sup> /h]	350	500	530
RPM	1150	1100	1100
Noise level at 3m [dB[A]]	24-45	28-47	28-47
Operating temperature [°C]	-25 up to +55	-25 up to +50	-25 up to +50
Casing material	aluzink	aluzink	aluzink
Insulation	25 mm mineral wool	25 mm mineral wool	25 mm mineral wool
Filter: exhaust	G4	G4	G4
intake	F7 (EU7)	F7 (EU7)	F7 (EU7)
Duct connection diameter, [mm]	∅ 125	∅ 150	∅ 160
Weight, [kg]	45	49	49
Recuperation efficiency	up to 78%	up to 88%	up to 88%
Heat exchanger type	cross-flow type	cross-flow type	cross-flow type
Heat exchanger material	aluminum	aluminum	aluminum

**Technical data:**

	VUT 600 H	VUT 1000 H	VUT 2000 H
Unit supply voltage [V / 50 Hz]	1~ 230	1~ 230	1~ 230
Maximum fan power [W]	2pcs. x 195	2pcs. x 410	2pcs. x 650
Fan current [A]	2pcs. x 0,86	2pcs. x 1,8	2pcs. x 2,84
Total power of the unit [W]	390	820	1300
Total current of the unit [A]	1,72	3,6	5,68
Air capacity [m <sup>3</sup> /h]	600	1200	2200
RPM	1350	1850	1150
Noise level at 3m [dB[A]]	32-48	60	65
Operating temperature [°C]	-25 up to +55	-25 up to +40	-25 up to +40
Casing material	aluzink	aluzink	aluzink
Insulation	25 mm mineral wool	50 mm mineral wool	50 mm mineral wool
Filter: exhaust	G4	G4	G4
intake	F7 (EU7)	G4 (F7)*	G4 (F7)*
Duct connection diameter, [mm]	∅ 200	∅ 250	∅ 315
Weight, [kg]	54	85	96
Recuperation efficiency	up to 85%	up to 88%	up to 87%
Heat exchanger type	cross-flow type	cross-flow type	cross-flow type
Heat exchanger material	aluminum	aluminum	aluminum

\*option

**Unit overall dimensions:**

Type	Dimensions, [mm]									
	∅D	B	B1	B2	B3	H	H1	H2	L	L1
VUT 350 H	124	416	300	54	207	603	230	148	722	768
VUT 500 H	149	416	300	54	207	603	230	148	722	768
VUT 530 H	159	416	300	54	207	603	230	148	722	768
VUT 600 H	199	416	300	54	207	603	230	148	722	768
VUT 1000 H	248	548	496	60	213	794	290	200	802	850
VUT 2000 H	313	846	796	235	588	968	360	246	1000	1050

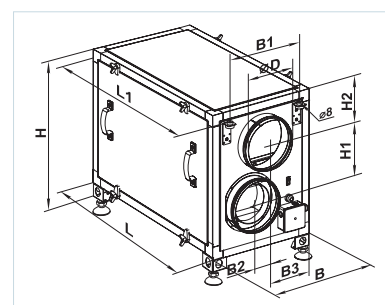

VENTS VUT H

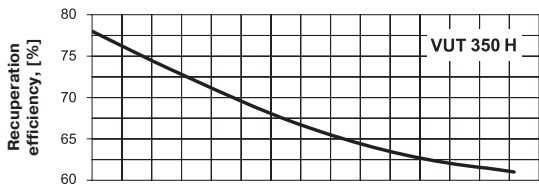
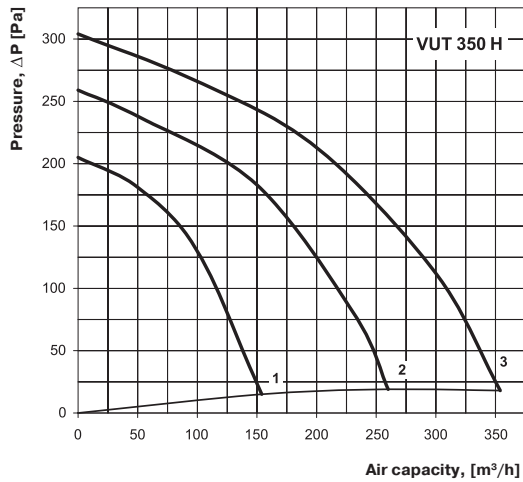

Sound-power level	Hz	Octave-frequency band [Hz]								
		Tot.	63	125	250	500	1000	2000	4000	8000
$L_{WA}$ to inlet	dB(A)	52	30	48	47	37	43	40	32	20
$L_{WA}$ to outlet	dB(A)	61	39	56	58	53	48	47	37	23
$L_{WA}$ to environment	dB(A)	31	22	23	30	27	21	16	20	22

VENTS VUT H

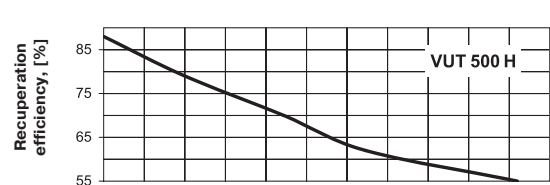
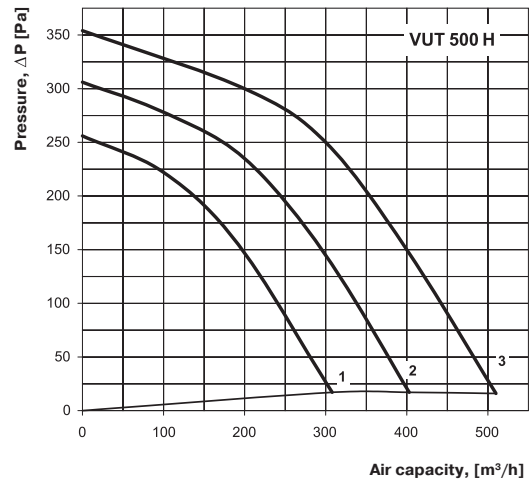

Sound-power level	Hz	Octave-frequency band [Hz]								
		Tot.	63	125	250	500	1000	2000	4000	8000
$L_{WA}$ to inlet	dB(A)	54	33	49	51	40	45	43	34	22
$L_{WA}$ to outlet	dB(A)	65	41	58	59	55	48	48	39	27
$L_{WA}$ to environment	dB(A)	37	25	26	33	29	20	19	22	23

VENTS VUT H

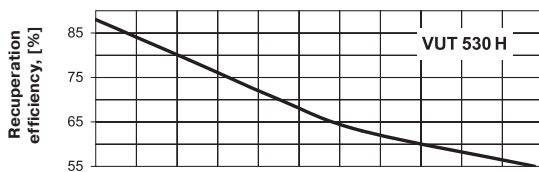
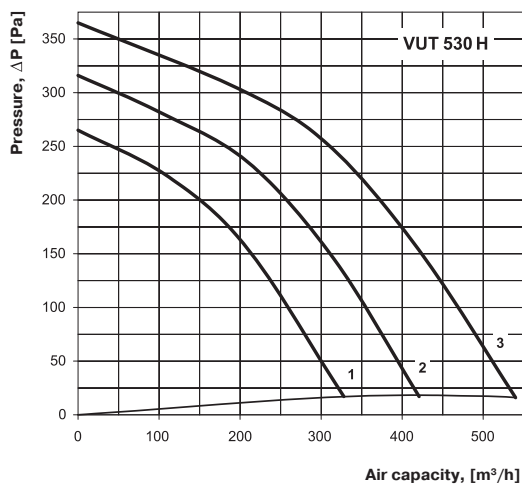

Sound-power level	Hz	Octave-frequency band [Hz]								
		Tot.	63	125	250	500	1000	2000	4000	8000
$L_{WA}$ to inlet	dB(A)	55	33	51	50	39	46	41	34	21
$L_{WA}$ to outlet	dB(A)	62	43	58	60	57	49	48	38	26
$L_{WA}$ to environment	dB(A)	36	25	26	33	30	20	18	23	25

VENTS VUT H

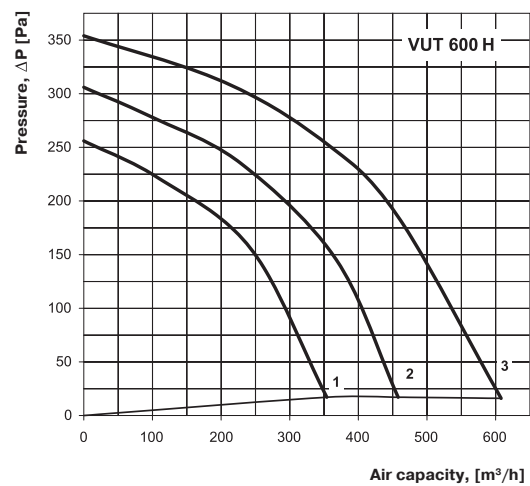

Sound-power level	Hz	Octave-frequency band [Hz]								
		Tot.	63	125	250	500	1000	2000	4000	8000
$L_{WA}$ to inlet	dB(A)	57	36	53	53	41	48	46	38	25
$L_{WA}$ to outlet	dB(A)	66	44	61	63	59	50	50	39	29
$L_{WA}$ to environment	dB(A)	40	26	29	37	35	25	23	26	27

**VENTS VUT H**

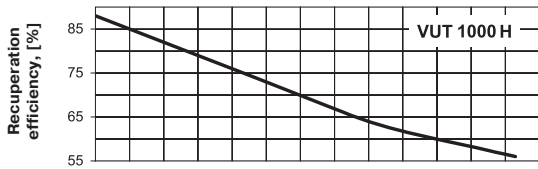
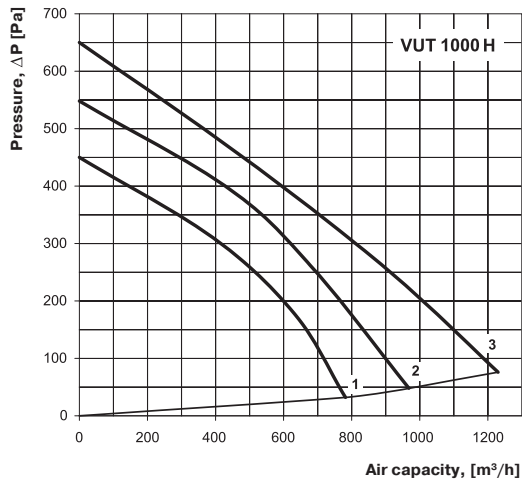

Sound-power level	Hz	Octave-frequency band [Hz]								
		Tot.	63	125	250	500	1000	2000	4000	8000
$L_{WA}$ to inlet	dB(A)	67	70	66	66	67	63	62	60	56
$L_{WA}$ to outlet	dB(A)	70	70	70	68	68	66	62	59	57
$L_{WA}$ to environment	dB(A)	46	57	54	49	54	39	39	34	32

**VENTS VUT H**

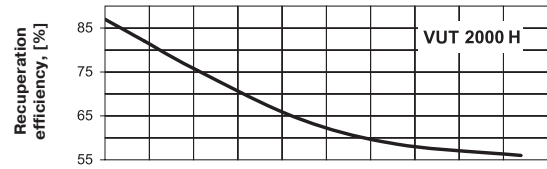
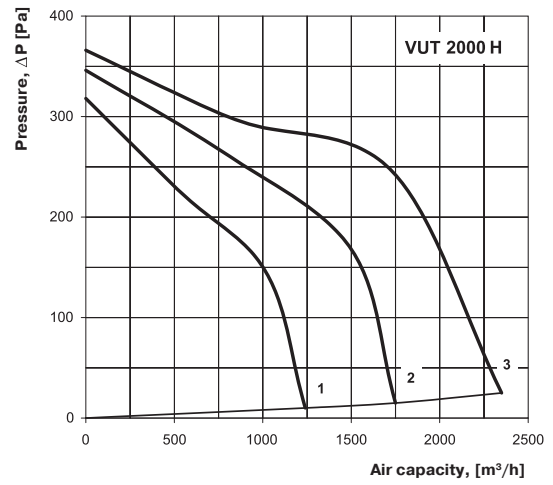

Sound-power level	Hz	Octave-frequency band [Hz]								
		Tot.	63	125	250	500	1000	2000	4000	8000
$L_{WA}$ to inlet	dB(A)	79	82	83	79	71	70	69	68	60
$L_{WA}$ to outlet	dB(A)	81	82	82	77	72	79	73	74	67
$L_{WA}$ to environment	dB(A)	55	65	66	60	52	49	46	40	38



VUT H unit air exchange example in the flat.

VENTS VUT H  
 AIR HANDLING UNIT WITH  
 HEAT RECOVERY SERIES

Series  
**VENTS VUT H EC**



Speed controller R-1/010



Air handling units with the air capacity up to **600 m<sup>3</sup>/h** and recuperation efficiency up to 95% in compact sound- and heat-insulated casing.

■ **Description**

VUT H air handling unit is a complete air handling unit designed to provide both supply and exhaust ventilation with air filtering and heat recovery. The extract air energy is used to heat up the supply fresh air through the heat exchanger. Applied in ventilation and conditioning systems for various premises requiring economic solution and controllable air exchange. EC-motors reduce energy consumption by 1.5-3 times and ensure high efficiency combined with low noise level. All the models are designed for connection to 160 and 200 mm round ducts.

■ **Casing**

The casing is made from aluminium profile, double-skinned with 20 mm mineral wool heat- and sound-resistant insulating layer.

■ **Filter**

Two incorporated G4 panel filters for extract air ventilation and F7 filters for supply air ventilation are supplied with the unit.

■ **Motor**

The double-inlet impellers with forward curved blades are powered by high-efficient electronically commutated (EC) external rotor motors. As of today such motor type is the most state-of-the-art and progressive solution for energy saving. EC motors are featured with high efficiency and the best control over the whole speed range. Premium efficiency (reaching 90%) is an absolute privilege of electronically commutated motor.

■ **Heat exchanger**

The cross-flow air-to-air heat exchanger is made of polystyrene plates. Whenever heat recovery is not required the heat exchanger block can be easily replaced by a "summer" block. The unit is also equipped with the drain pan for condensate drainage as well as built-in icing protecting system. Its operating principle is based on switching the supply fan off as the temperature sensor requires. Then the supply fan switches on and the unit operates under the rated conditions.

■ **Control**

The unit is controlled by means of external control signal 0-10 V (e.g., R-1/010 speed controller for EC-motors). Air capacity control depends on temperature level, pressure and smoke conditions and other system parameters. Should the value of the control parameter get changed the EC-motor changes its rotation speed accordingly and boosts as much air flow as required for the ventilation system.

■ **Mounting**

Air handling unit is mounted on the floor, suspended to the ceiling by means of a seat angle with inserted vibration-damping element or attached to a wall with brackets. The unit can be mounted either in service spaces or in main premises above the suspended ceiling, in the pocket or can be placed directly in the room. Mounting in any position shall provide correct condensation water drainage. Access for maintenance shall be provide through the side panels.

**Accessories to air handling units:**

Type	G4 replaceable filter	F7 replaceable filter	Summer block
VUT 300-1 H EC VUT 300-2 H EC VUT 400 H EC VUT 600 H EC	SF VUT 300-600 H EC G4	SF VUT 300-600 H EC F7	VL VUT 300-600 H EC

**Designation key:**

Series	Rated air capacity, m <sup>3</sup> /h	Duct connection	Motor type
<b>VENTS VUT</b>	300; 400; 600	<b>H</b> – horizontal	<b>EC</b> – electronically commutated synchronous motor

**Accessories**



page 240    page 240    page 294    page 296    page 305

**Offered options to the units**

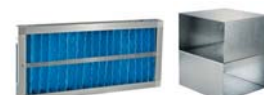

page 196    page 196

**Technical data:**

	VUT 300-1 H EC	VUT 300-2 H EC	VUT 400 H EC	VUT 600 H EC
Unit supply voltage [V / 50 Hz]	1~ 230		1~ 230	1~ 230
Maximum fan power [W]	2pcs. x 70		2pcs. x 175	2pcs. x 175
Fan current [A]	2pcs. x 0,60		2pcs. x 1,3	2pcs. x 1,3
Total power of the unit [W]	140		350	350
Total current of the unit [A]	1,2		2,6	2,6
Air capacity [m³/h]	300		400	600
RPM	1380		1340	2150
Noise level at 3m [dB(A)]	24-45		28-47	28-47
Operating temperature [°C]	-25 up to +60		-25 up to +60	-25 up to +60
Casing material	aluzink		aluzink	aluzink
Insulation	25 mm mineral wool		25 mm mineral wool	
Filter: exhaust	G4		G4	G4
intake	F7 (EU7)		F7 (EU7)	F7 (EU7)
Duct connection diameter, [mm]	∅ 150	∅ 160	∅ 200	∅ 200
Weight, [kg]	36		37	37
Recuperation efficiency	up to 95%		up to 95%	up to 95%
Heat exchanger type	counter-flow		counter-flow	counter-flow
Heat exchanger material	polystyrene		polystyrene	polystyrene

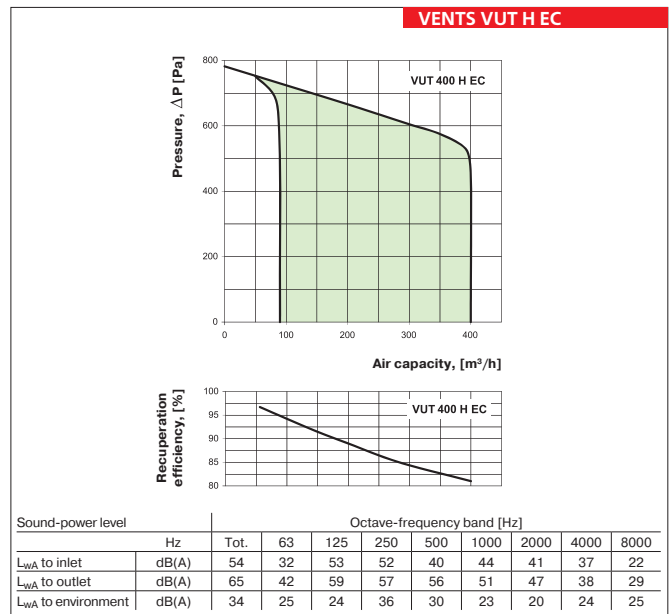
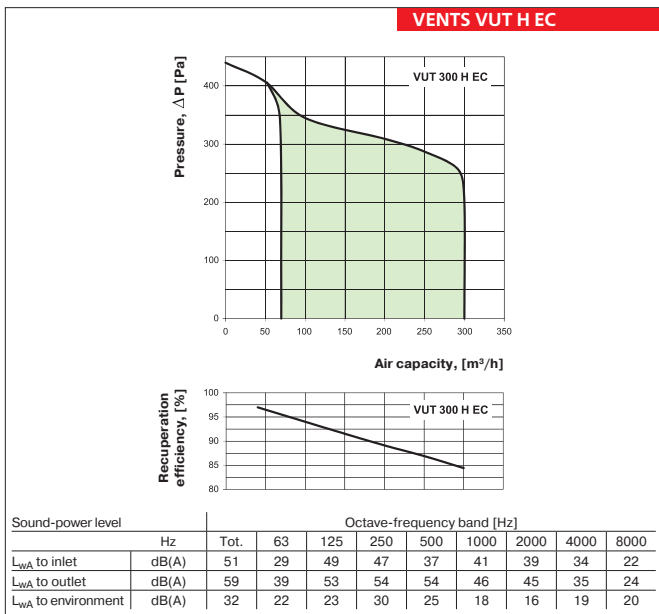

**Unit overall dimensions:**

Type	Dimensions, [mm]									
	∅D	B	B1	B2	B3	H	H1	H2	L	L1
VUT 300-1 H EC	149	420	390	100	159	562	215	147	829	876
VUT 300-2 H EC	159	420	390	100	159	562	215	147	829	876
VUT 400 H EC	199	420	390	100	159	562	215	147	829	876
VUT 600 H EC	199	420	390	100	159	562	215	147	829	876

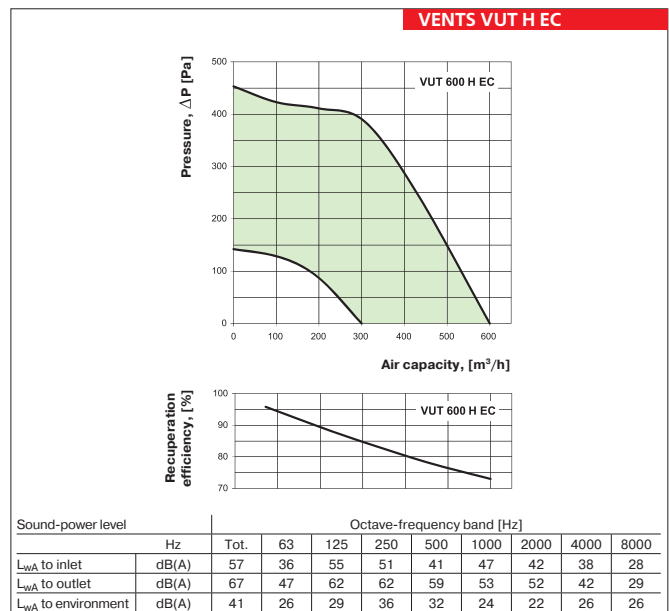
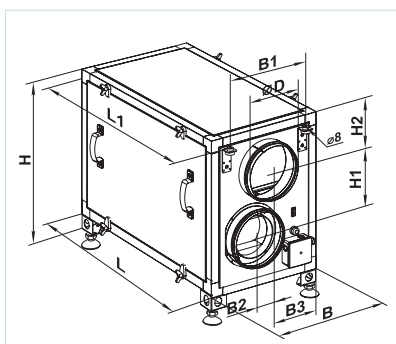

**VENTS**  
 AIR HANDLING UNIT WITH  
 HEAT RECOVERY SERIES  
**VUT H EC**



Series  
**VENTS VUT EH**



LCD control panel

Air handling units with the air capacity up to **2200 m<sup>3</sup>/h** and recuperation efficiency up to 85% in sound-proof and heat-insulated casing with electric heater.

Series  
**VENTS VUT WH**



SA5908 control panel

Air handling units with the air capacity up to **2100 m<sup>3</sup>/h** and recuperation efficiency up to 78% in sound-proof and heat-insulated casing with water heater.

■ **Description**

Air handling units VUT EH with electric heater and VUT WH with water heater are the complete air handling units designed to provide both supply and exhaust ventilation with air filtering and heat recovery. The exhaust air energy is used to heat up the supply fresh air through the heat exchanger. All the models are designed for connection with Ø 125, 150, 160, 200, 250, 315 mm round ducts.

■ **Modifications**

**VUT EH** – a range of compact energy saving air handling units (AHU) equipped with supply and exhaust centrifugal fans, cross-flow heat recovery elements, electric heating coils and air filters.

**VUT WH** – a range of compact energy saving air handling units (AHU) equipped with supply and exhaust centrifugal fans, cross-flow heat recovery elements, water or glycol heating coils and air filters.

■ **Casing**

The casing is manufactured from aluminum-zinc compound with 25 mm thick mineral wool heat- and sound-insulating layer.

■ **Filter**

Two incorporated G4 panel filters for extract air ventilation and F7 filters for supply air ventilation are supplied with the unit.

■ **Fans**

The units are equipped with supply and exhaust centrifugal double-inlet fans with forward curved blades and built-in thermostat with automatic restart. The electric motors and impellers are dynamically balanced in two planes. The ball-bearings used with motors are designed for at least 40 000 hours operation and are maintenance-free.

■ **Heat exchanger**

The heat exchangers have high efficiency and are manufactured from aluminium plates. The unit is also equipped with the drain pan for condensate drainage.

■ **Heater**

If the external temperature is too low and/or the heat energy transfer from the extract air is insufficient to heat up the incoming air to the required temperature, the heater will automatically be turned on. The control system regulates the heating power to maintain the indoor temperature as set by the user. The units supplied with water heating coils are marked as VUT WH, and the units with electric heaters are marked as VUT EH. Water heating coils are available with two or four rows depending on required heating power.

■ **Automation and control system**

The unit is equipped with built-in automation system with multifunctional control panel with graphic LCD indicator. The standard delivery set includes 10 m wire for connection to the control panel. Electronic freezing protection is applied to prevent the heat exchanger freezing. It includes the by-pass damper and the heater. It operates due to opening of by-pass air shutter as the temperature sensor requires to let the air flow pass through the heat exchanger through the by-pass duct. During the heat exchanger defrost cycle the supplied air is warmed up in the heater up to the required temperature. During the defrost process the warm exhaust air warms the heat exchanger. After that the by-pass damper closes again, the heater is switched off, supply air warms up again through the heat exchanger and the unit continues operating under rated conditions.

■ **VUT EH control and protection functions**

- ▶ safe start-up and shutdown of the unit;
- ▶ setting and maintaining the desired temperature of the supply air with the control panel;
- ▶ motor speed control and regulation of the unit air capacity accordingly by means of the control panel;
- ▶ control of the external intake and exhaust air flow regulating damper actuators;

**Designation key:** \_\_\_\_\_

Series	Rated air capacity, m <sup>3</sup> /h	Heater type	Duct connection	Row number of the heater
<b>VENTS VUT</b>	350; 500; 530; 600; 1000; 2000;	<b>E</b> – electric heater; <b>W</b> – water heater	<b>H</b> – horizontal duct connection	<b>2</b> – two rows; <b>4</b> – four rows

**Accessories**



page 240    page 240    page 280    page 294    page 296    page 305

**Offered options to the units**

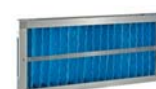

page 199



- ▶ working-out the required patterns while the unit start-up and shutdown;
- ▶ programming daily and weekly schedules by user;
- ▶ active electric heater overheating protection;
- ▶ disabling electric heater operation when the motor is not running;
- ▶ two electric heater over-heating thermostats;
- ▶ automatic switch ensuring the short circuit protection of the automation system;
- ▶ controlling filter clogging.

**VUT WH control and protection functions**

- ▶ safe start-up and shutdown of the unit;
- ▶ supply air temperature controlling by means of actuating three-way valve regulating the feed of the heat medium into the water coils;

- ▶ water (glycol) heating coils freezing protection as the leaving air temperature and leaving heat medium temperature sensors require;
- ▶ controlling the heat exchanger by-pass actuator;
- ▶ control of the external circulation pump operation installed on the heat medium feed line entering into the water coils;
- ▶ heat exchanger freezing protection;
- ▶ control of the intake and exhaust fan operation;
- ▶ air clogging control according to engine hours;
- ▶ control of the external intake and exhaust air flow regulating damper actuators.

Air handling unit is equipped with the remote control panel that provides:

- ▶ starting-up/shutdown of the ventilation unit;

- ▶ setting the required air flow;
- ▶ setting the required supply air temperature;
- ▶ displaying the temperature in the room.

**Mounting**

The air handling unit is mounted on the floor, suspended to the ceiling by means of a seat angle with inserted vibration-damping element or attached to a wall with brackets. The unit can be mounted either in service spaces or in main premises above the suspended ceiling, in the pocket or can be placed directly in the room. Mounting in any position shall provide the correct condensate drainage. Access for the unit maintenance and filter cleaning shall be provided through the side panels.

**Unit overall dimensions:**

Type	Dimensions, [mm]											
	∅D	B	B1	B2	B3	H	H1	H2	H3	L	L1	L2
VUT 350 EH	124	497	403	248	348	554	-	111	230	954	996	1054
VUT 500 EH	149	497	403	248	348	554	-	111	230	954	996	1054
VUT 530 EH	159	497	403	248	348	554	-	111	230	954	996	1054
VUT 600 EH	199	497	403	248	348	554	-	111	230	954	996	1054
VUT 1000 EH	249	613	460	306	386	698	832	154	280	1071	1117	1171
VUT 1000 WH	249	613	460	306	386	698	832	154	280	1071	1117	1171
VUT 2000 EH	314	842	581	320	520	814	947	201	595	1345	1388	1445
VUT 2000 WH	314	842	581	320	520	814	947	201	595	1345	1388	1445

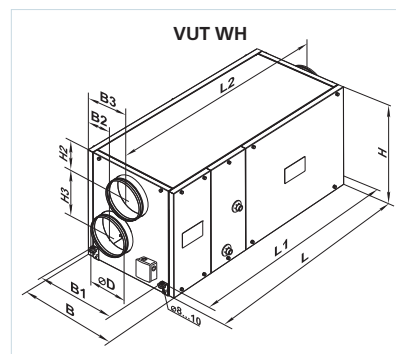
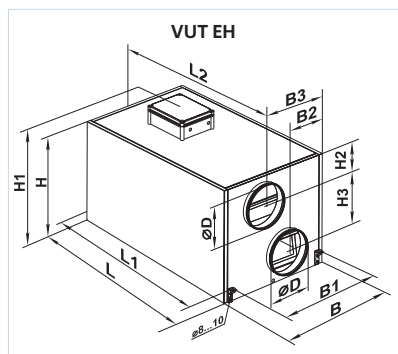

**Accessories for air handling units:**

Type	Replaceable filter (panel filter) G4	Replaceable filter (panel filter) F7
VUT 350 EH		
VUT 500 EH		
VUT 530 EH	SF VUT 300-600 EH/WH G4	SF VUT 300-600 EH/WH F7
VUT 600 EH		
VUT 1000 EH	SF VUT 1000 EH/WH G4	SF VUT 1000 EH/WH F7
VUT 2000 EH	SF VUT 2000 EH/WH G4	SF VUT 2000 EH/WH F7
VUT 1000 WH-2		
VUT 1000 WH-4	SF VUT 1000 EH/WH G4	SF VUT 1000 EH/WH F7
VUT 2000 WH-2		
VUT 2000 WH-4	SF VUT 2000 EH/WH G4	SF VUT 2000 EH/WH F7

AIR HANDLING UNIT WITH HEAT RECOVERY SERIES  
 VENTS  
 VUT EH / WH

# AIR HANDLING UNITS WITH HEAT RECOVERY

## Technical data:

	VUT 350 EH	VUT 500 EH	VUT 530 EH	VUT 600 EH
Unit supply voltage [V / 50 Hz]	1~230	1~230	1~230	1~230
Maximum fan power [W]	2pcs. x 130	2pcs. x 150	2pcs. x 150	2pcs. x 195
Fan current [A]	2pcs. x 0,60	2pcs. x 0,66	2pcs. x 0,66	2pcs. x 0,86
Electric heater capacity [kW]	3	3	4	4
Electric heater current [A]	13	13	17,4	17,4
Total power of the unit [kW]	3,26	3,3	4,3	4,39
Total current of the unit [A]	14,2	14,32	18,72	19,1
Air capacity [m <sup>3</sup> /h]	350	500	530	600
RPM	1150	1100	1100	1350
Noise level at 3m [dB(A)]	24-45	28-47	28-47	32-48
Operating temperature [°C]	-25 up to +55	-25 up to +50	-25 up to +50	-25 up to +55
Casing material	aluzink	aluzink	aluzink	aluzink
Insulation	25 mm mineral wool	25 mm mineral wool	25 mm mineral wool	25 mm mineral wool
Filter: exhaust	G4	G4	G4	G4
intake	F7 (EU7)	F7 (EU7)	F7 (EU7)	F7 (EU7)
Duct connection diameter, [mm]	∅ 125	∅ 150	∅ 160	∅ 200
Weight, [kg]	45	49	49	54
Recuperation efficiency	up to 78%	up to 88%	up to 88%	up to 85%
Heat exchanger type	cross-flow type	cross-flow type	cross-flow type	cross-flow type
Heat exchanger material	aluminum	aluminum	aluminum	aluminum

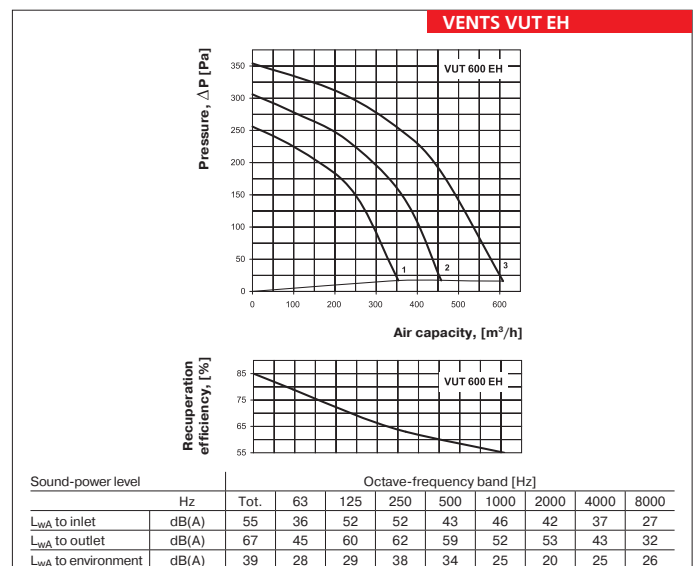
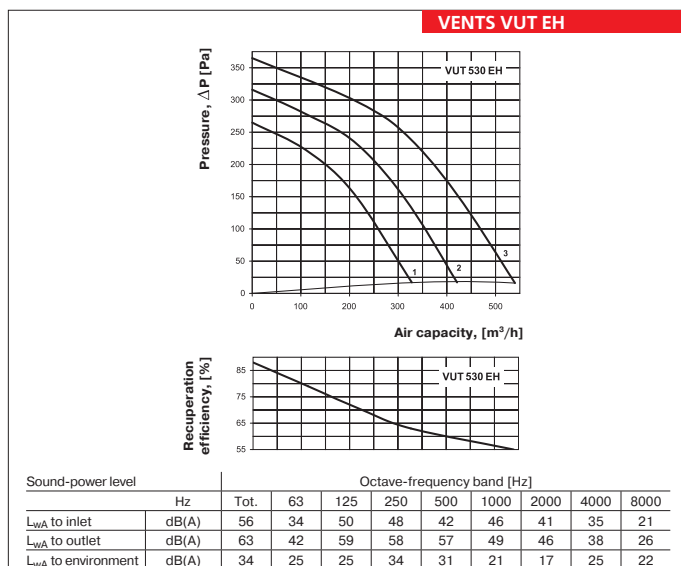
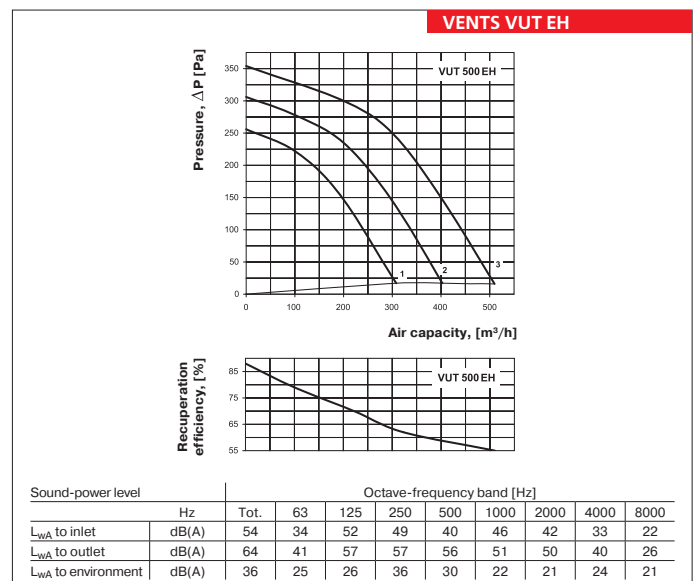
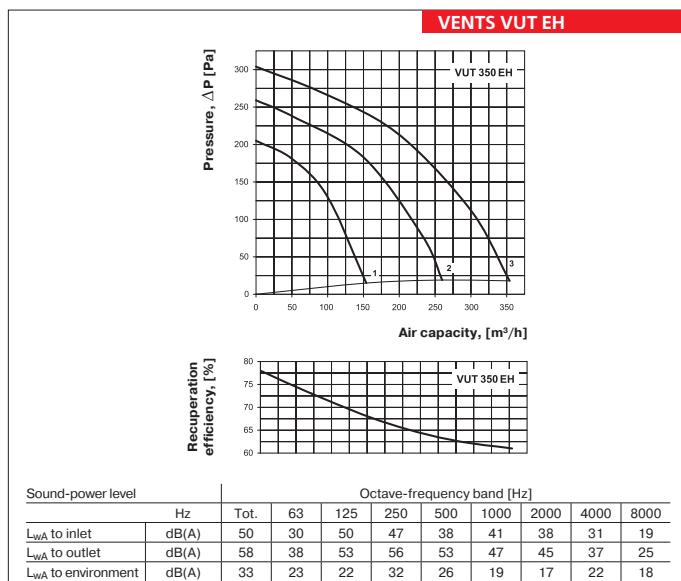

**Technical data:**

	VUT 1000 EH	VUT 1000 WH-2 VUT 1000 WH-4	VUT 2000 EH	VUT 2000 WH-2 VUT 2000 WH-4
Unit supply voltage [V / 50 Hz]	3~400	1~230	3~400	1~230
Maximum fan power [W]		2pcs. x 410		2pcs. x 650
Fan current [A]		2pcs. x 1,8		2pcs. x 2,84
Electric heater capacity [kW]	9,0	-	18,0	-
Electric heater current [A]	13,0	-	26,0	-
Number of water (glycol) coil rows	-	2 or 4	-	2 or 4
Total power of the unit [kW]	9,80	0,82	19,30	1,30
Total current of the unit [A]	16,6	3,6	31,7	5,68
Air capacity [m <sup>3</sup> /h]	1200	1100	2200	2100
RPM		1850		1150
Noise level at 3m [dB(A)]		60		65
Operating temperature [°C]		-25 up to +40		-25 up to +40
Casing material		aluzink		aluzink
Insulation		50 mm mineral wool		50 mm mineral wool
Filter: exhaust		G4		G4
intake		G4 (F7)*		G4 (F7)*
Duct connection diameter, [mm]		∅250		∅315
Weight, [kg]	85	88	96	99
Recuperation efficiency		up to 78%		up to 77%
Heat exchanger type		cross-flow type		cross-flow type
Heat exchanger material		aluminum		aluminum

\*option

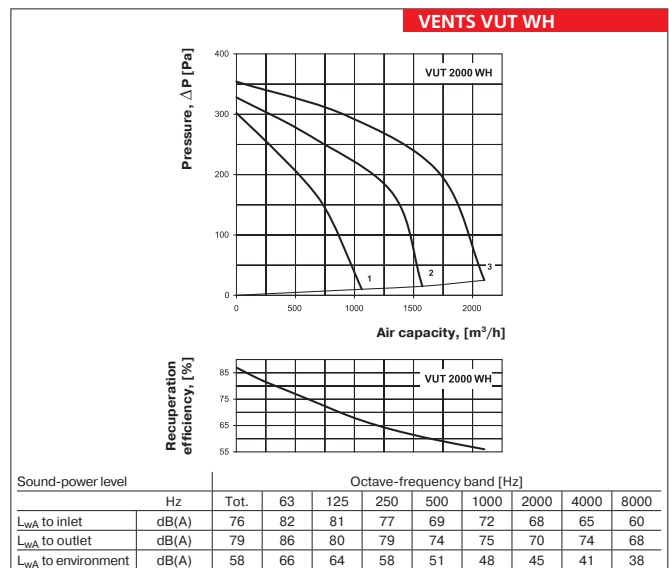
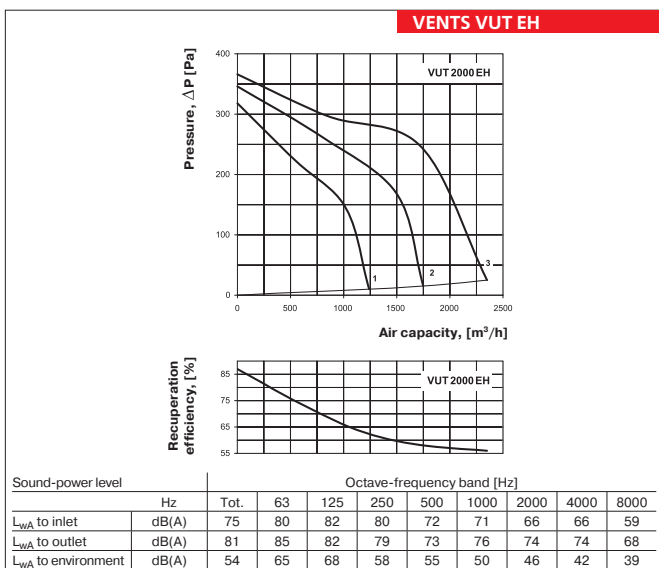
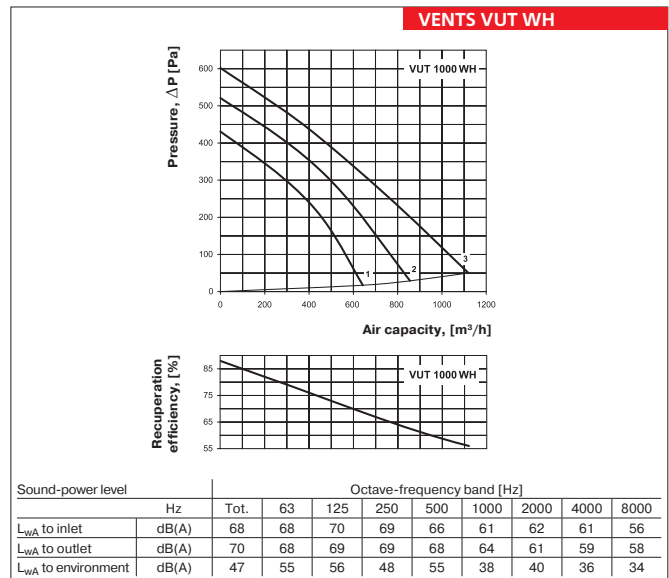
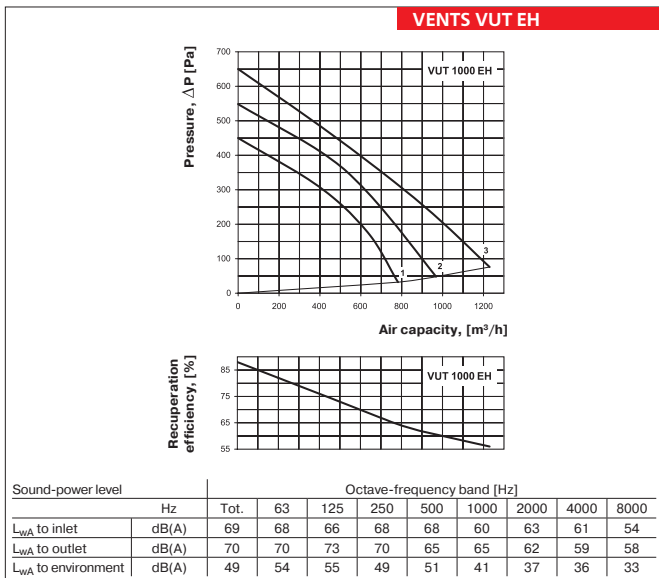

VENTS  
 AIR HANDLING UNIT WITH  
 HEAT RECOVERY SERIES  
 VUT EH / WH

## Hot water coil parameters:

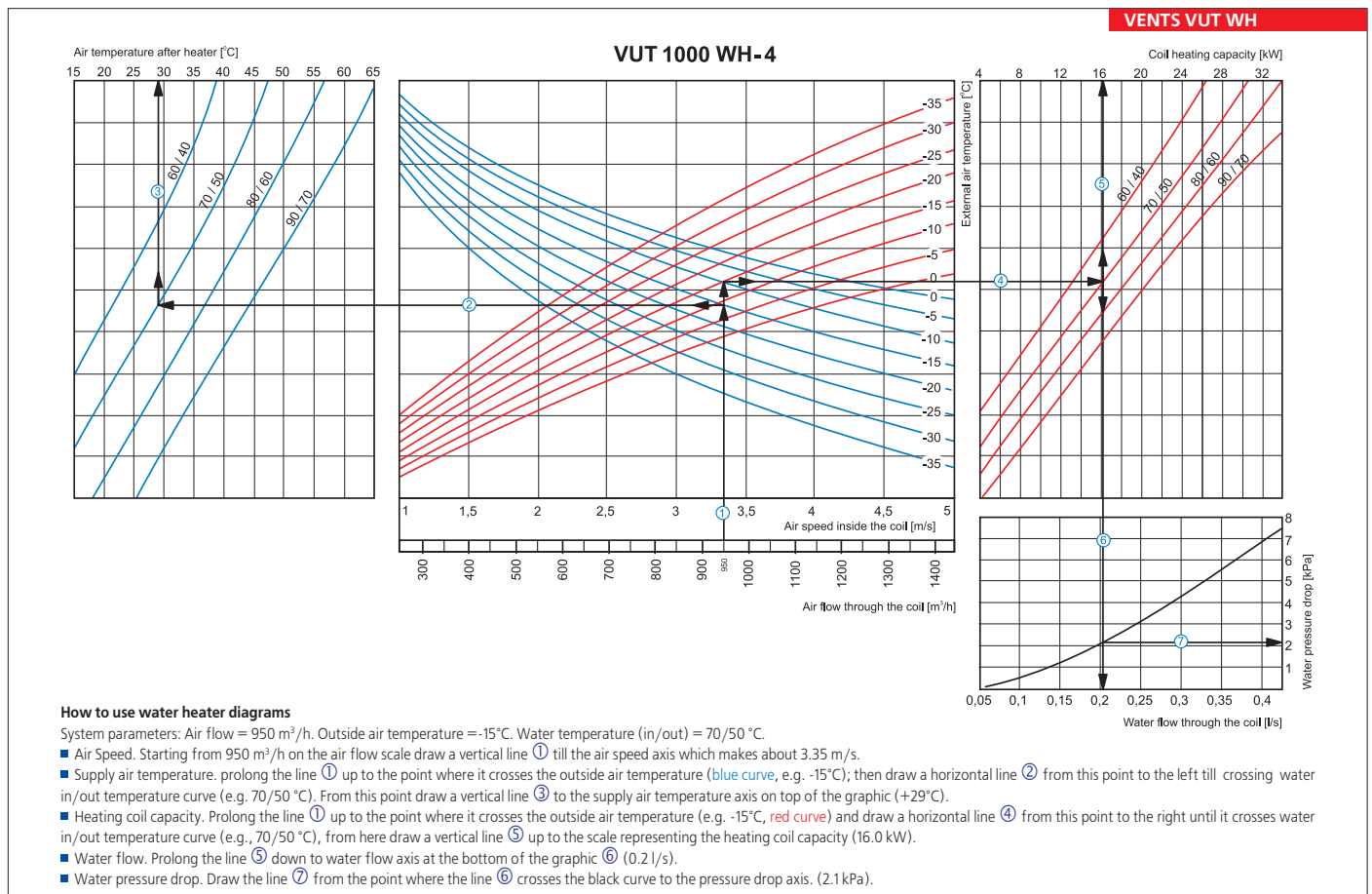
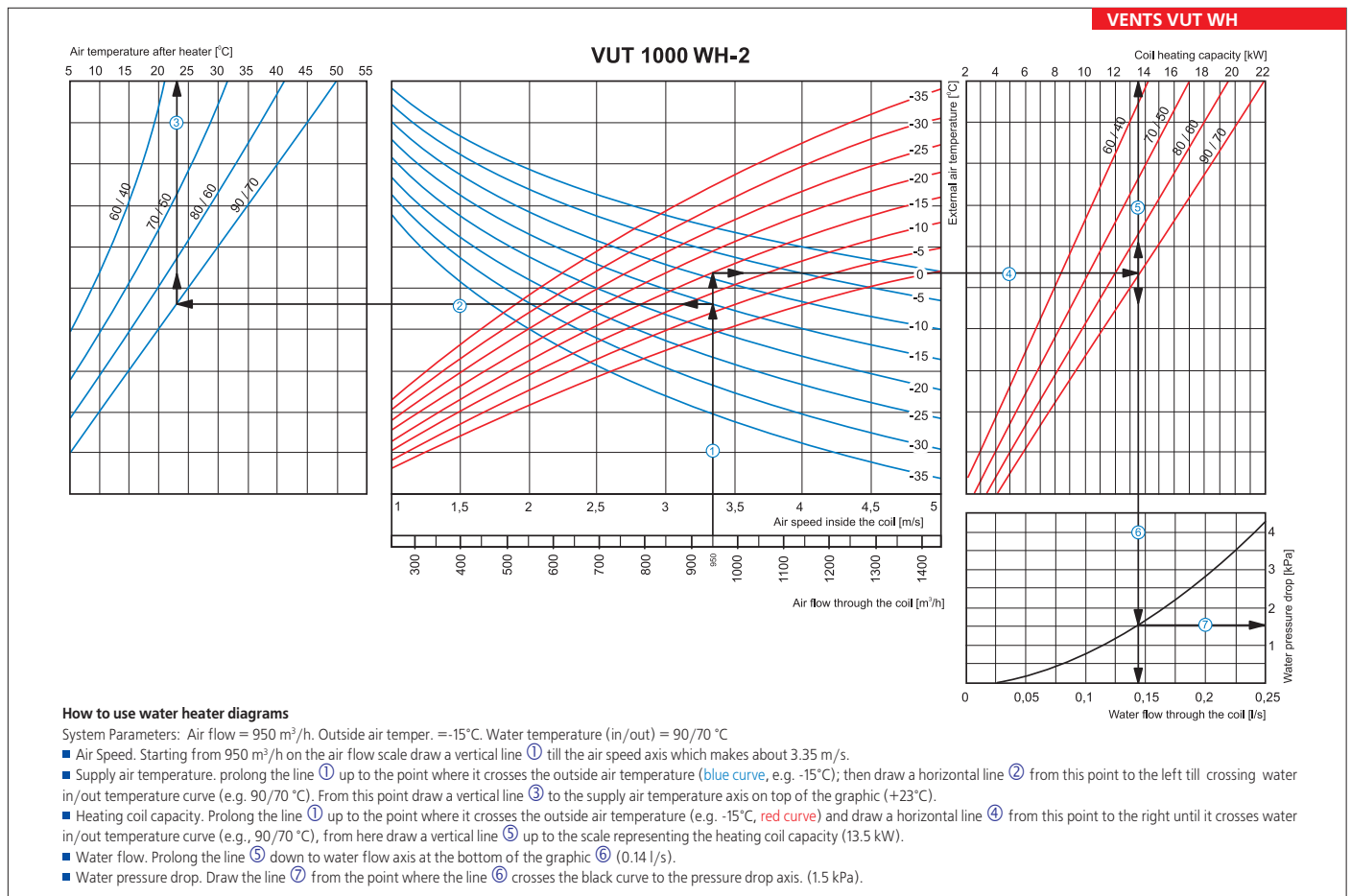

**Hot water coil parameters:**

**VENTS VUT WH**

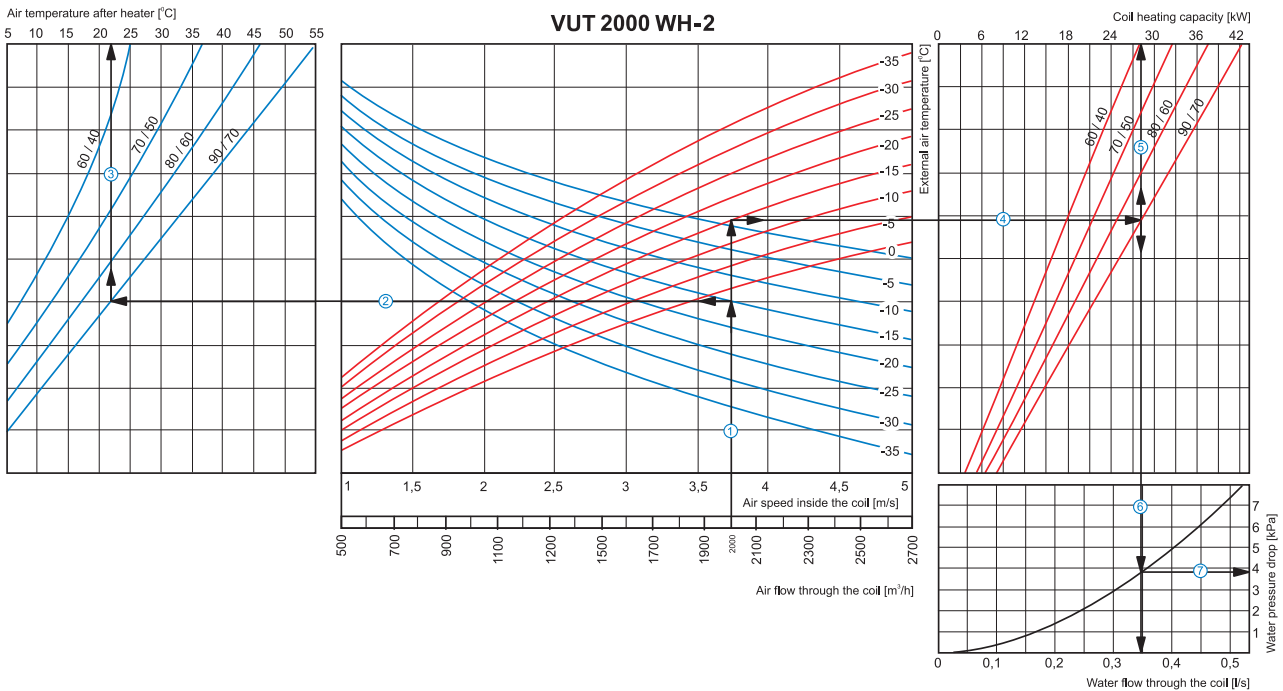

**How to use water heater diagrams**

System Parameters: Air flow = 2000 m<sup>3</sup>/h. Outside air temperature = -15°C. Water temperature (in/out) = 90/70 °C.

- Air Speed. Starting from 2000 m<sup>3</sup>/h on the air flow scale draw a vertical line ① till the air speed axis. (3.75 m/s).
- Supply air temperature. Prolong the line ① up to the point where it crosses the outside air temperature (blue curve, e.g. -15°C); then draw a horizontal line ② from this point to the left till crossing water in/out temperature curve (e.g. 90/70 °C). From this point draw a vertical line ③ to the supply air temperature axis on top of the graphic (+22°C).
- Heating coil capacity. Prolong the line ① up to the point where it crosses the outside air temperature (e.g. -15°C, red curve) and draw a horizontal line ④ from this point to the right until it crosses water in/out temperature curve (e.g., 90/70 °C), from here draw a vertical line ⑤ up to the scale representing the heating coil capacity (28.0 kW).
- Water flow. Prolong the line ⑤ down to water flow axis at the bottom of the graphic ⑥ (0.35 l/s).
- Water pressure drop. Draw the line ⑦ from the point where the line ⑥ crosses the black curve to the pressure drop axis. (3.8 kPa).

**VENTS VUT WH**

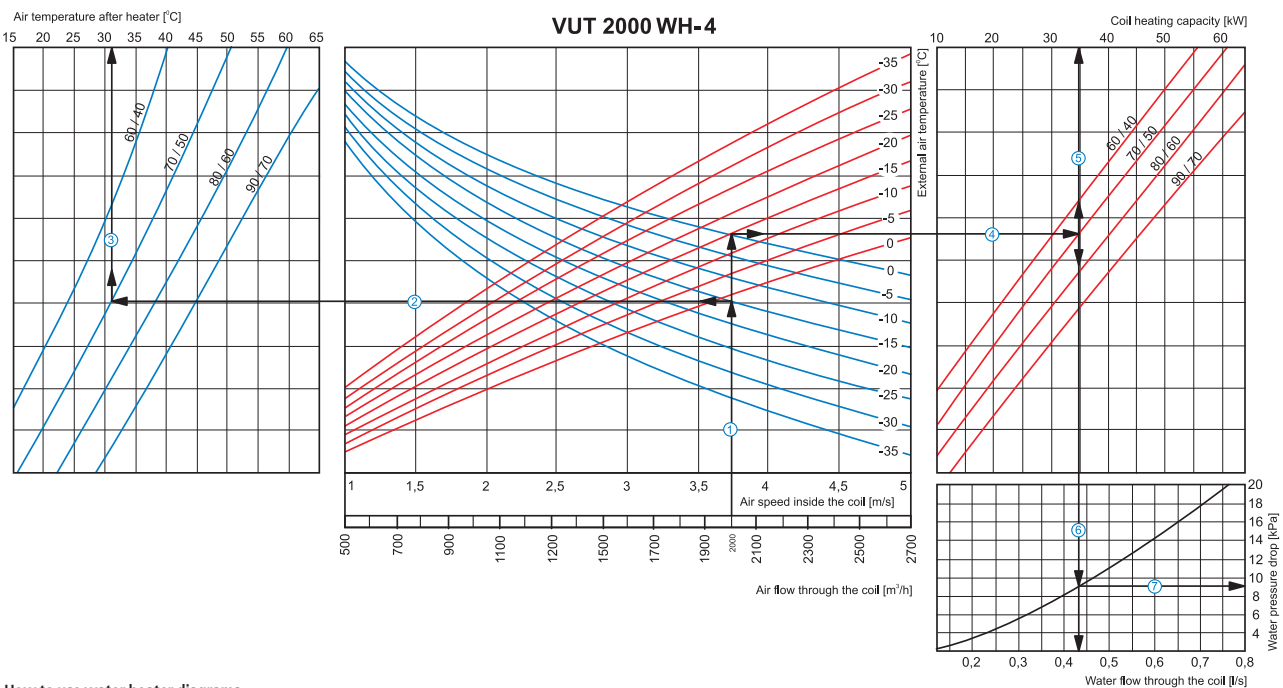

**How to use water heater diagrams**

System Parameters: Air flow = 2000 m<sup>3</sup>/h. Outside air temperature = -15°C. Water temperature (in/out) = 70/50 °C.

- Air Speed. Starting from 2000 m<sup>3</sup>/h on the air flow scale draw a vertical line ① till the air speed axis which makes about 3.75 m/s.
- Supply air temperature. Prolong the line ① up to the point where it crosses the outside air temperature (blue curve, e.g. -15°C); then draw a horizontal line ② from this point to the left till crossing water in/out temperature curve (e.g. 70/50 °C). From this point draw a vertical line ③ to the supply air temperature axis on top of the graphic (+31°C).
- Heating coil capacity. Prolong the line ① up to the point where it crosses the outside air temperature (e.g. -15°C, red curve) and draw a horizontal line ④ from this point to the right until it crosses water in/out temperature curve (e.g., 70/50 °C), from here draw a vertical line ⑤ up to the scale representing the heating coil capacity (35.0 kW).
- Water flow. Prolong the line ⑤ down to water flow axis at the bottom of the graphic ⑥ (0.43 l/s).
- Water pressure drop. Draw the line ⑦ from the point where the line ⑥ crosses the black curve to the pressure drop axis. (9.0 kPa).

VENTS  
AIR HANDLING UNIT WITH  
HEAT RECOVERY SERIES  
VUT EH / WH



Series  
**VENTS VUT EH EC**



LCD control panel



Air handling units with the air capacity up to **600 m<sup>3</sup>/h** and recuperation efficiency up to 95% in the sound- and heat-insulated casing.

Series  
**VENTS VUT WH EC**



SAS908 control panel



Air handling units with the air capacity up to **550 m<sup>3</sup>/h** and the recuperation efficiency up to 95% in the sound- and heat-insulated casing with the water heating coils.

■ **Description**

VUT EH EC air handling units with the electric heating battery and VUT WH EC with water heating coils are the complete ventilation units designed to provide both supply and exhaust ventilation, air filtration and cleaning as well as removal of contaminated exhaust air. The exhaust air energy is transferred to supply air through the plate heat exchanger. Applied in ventilation and conditioning systems for various premises requiring economic solution and controllable air exchange. EC-motors reduce energy consumption by 1.5-3 times and ensure high efficiency and low noise level at the same time. All the models are compatible with Ø 150, 160 and 200 mm round ducts.

■ **Modifications**

**VUT EH EC** – a range of compact Energy saving Air Handling Units (AHU) equipped with intake and exhaust centrifugal fans with EC motors, counter-

flow heat recovery elements, electric heater and air filters.

**VUT WH EC** – a range of compact Energy saving Air Handling Units (AHU) equipped with supply and exhaust centrifugal fans with EC motors, counter-flow heat recovery elements, water or glycol heating coils and air filters.

■ **Casing**

The casing is manufactured from aluminum-zinc compound with internal 25 mm mineral wool heat- and sound- insulating layer.

■ **Filter**

Two incorporated G4 panel filters for extract air ventilation and F7 filters for supply air ventilation are supplied with the unit.

■ **Fans**

The double inlet impellers with forward curved blades are powered by high efficient electronically commutated (EC) direct current motors with external rotor. As of today, such motor type is the most advanced solution for energy saving. EC-motors are featured with high efficiency and the best control over the whole fan speed range. Premium efficiency (reaching 90%) is an absolute advantage of the electronically commutated motors.

■ **Heat recovery**

The units are equipped with the high efficient heat exchangers reaching up to 95%. VUT EH EC and VUT WH EC models are fitted with the counter-flow heat exchangers made of polystyrene. The unit is equipped with the drain pan at the bottom of the heat exchanger for condensate drainage.

**Designation key:**

Series	Rated air capacity, m <sup>3</sup> /h	Heater type	Duct connection	Motor type
<b>VENTS VUT</b>	300; 400; 600	<b>E</b> – electric heater; <b>W</b> – water heater	<b>H</b> – horizontal duct connection	<b>EC</b> – electronically commutated synchronous motor

**Accessories**



page 240    page 240    page 280    page 294    page 296    page 305

**Offered options to the units**

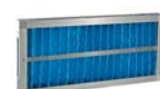

page 205



**■ Heater**

If the outside temperature is too low and/or heat energy transfer from the extract air is insufficient to heat up the incoming air to the required temperature, the heater automatically be turned on. The control system regulates the heating power to keep the indoor temperature as set by the user. The units supplied with the water heaters are marked as VUT WH, and the units with electric heaters are marked as VUT EH.

**■ Control and automation**

The unit is equipped with the built-in automation system with multifunctional control panel with graphic LED display.

The standard delivery set includes 10 m wire for connection to the control panel. Electronic freezing protection is prevents the heat exchanger freezing. It includes the by-pass damper and heater. The temperature sensor activates the by-pass air shutter opening to let the air flow pass through the heat exchanger by-pass duct. During the heat exchanger defrost cycle the supply air is warmed up in the heater up to the required temperature. During the defrosting process the warm exhaust air warms the heat exchanger. After that the by-pass damper closes again, the heater is switched off, supply air warms up again through the heat exchanger and the unit continues operating under rated conditions.

**■ VUT EH EC control and protection functions**

- ▶ safe start-up and shutdown of the unit;
- ▶ setting and maintaining the desired temperature of supply air with the control panel;
- ▶ motor speed control and air capacity regulation accordingly by means of the control panel;
- ▶ control of the external intake and exhaust air damper actuators;
- ▶ working out the required patterns while the unit start-up and shutdown;
- ▶ programming daily and weekly schedules by user;
- ▶ active electric heating elements overheating protection;
- ▶ disabling electric heater operation when the motor is not running;
- ▶ two electric heater over-heating thermostats;
- ▶ automatic switch ensuring the short circuit protection of the automation system;
- ▶ control of filter clogging.

**■ VUT WH (EC) control and protection functions**

- ▶ safe start-up and shutdown of the unit;
- ▶ supply air temperature control by means of actuating three-way valve regulating the feed of the heat medium into the water coils;
- ▶ water (glycol) heating coils freezing protection as the leaving air temperature and leaving heat medium temperature sensors require;
- ▶ controlling the heat exchanger by-pass actuator;

- ▶ control of the external circulation pump installed on the heat medium entering into the water coils;
- ▶ heat exchanger freezing protection;
- ▶ control of the supply and exhaust fans;
- ▶ air clogging controlling (according to engine hours);
- ▶ control of the external intake and exhaust air damper actuators.

The air handling unit is equipped with the remote control panel that provides:

- ▶ starting-up/shutdown of the ventilation unit;
- ▶ setting the required air capacity;
- ▶ setting the required supply air temperature;
- ▶ displaying the temperature in the room.

**■ Mounting**

Air handling unit is mounted on the floor, suspended to the ceiling by means of a seat angle with inserted vibration-damping element or attached to a wall with brackets. The unit can be mounted either in service spaces or in main premises above the suspended ceiling, in the pocket or the unit can be placed directly in the room. Mounting in any position shall provide the correct condensate drainage. Access for the unit maintenance and filter cleaning shall be reserved on the pane side.

**Accessories for air handling units:**

Type	G4 replaceable filter (panel filter)	F7 replaceable filter (panel filter)
VUT 300-1 EH EC VUT 300-2 EH EC VUT 400 EH EC VUT 600 EH EC VUT 300-1 WH EC VUT 300-2 WH EC VUT 400 WH EC VUT 600 WH EC	SF VUT 300-600 EH/WH G4	SF VUT 300-600 EH/WH F7

VENTS  
 VUT EH EC /  
 WH EC  
 AIR HANDLING UNIT WITH  
 HEAT RECOVERY SERIES

## AIR HANDLING UNITS WITH HEAT RECOVERY

### Unit overall dimensions:

Type	Dimensions, [mm]										
	∅D	B	B1	B2	B3	H	H2	H3	L	L1	L2
VUT 300-1 EH EC	149	500	403	161	249	555	127	231	1092	1137	1198
VUT 300-2 EH EC	159	500	403	161	249	555	127	231	1092	1137	1198
VUT 400 EH EC	199	500	403	161	249	555	127	231	1092	1137	1198
VUT 600 EH EC	199	500	403	161	249	555	127	231	1092	1137	1198
VUT 300-1 WH EC	149	500	403	161	249	555	127	231	1092	1137	1198
VUT 300-2 WH EC	159	500	403	161	249	555	127	231	1092	1137	1198
VUT 400 WH EC	199	500	403	161	249	555	127	231	1092	1137	1198
VUT 600 WH EC	199	500	403	161	249	555	127	231	1092	1137	1198

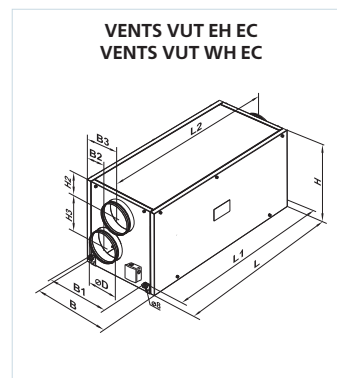

### Technical data:

	VUT 300-1 EH EC	VUT 300-2 EH EC	VUT 300-1 WH EC	VUT 300-2 WH EC
Unit supply voltage [V / 50 Hz]			1~ 230	
Maximum fan power [W]			2pcs. x 70	
Fan current [A]			2pcs. x 0,60	
Electric heater capacity [kW]	3,0			-
Electric heater current [A]	13,0			-
Number of water (glycol) coil rows	-			2
Total power of the unit [kW]	3,14			0,14
Total current of the unit [A]	14,2			1,2
Air capacity [m³/h]			300	
RPM			1380	
Noise level at 3m [dB[A]]	24-45			24-45
Operating temperature [°C]			-25 up to +60	
Casing material			aluzink	
Insulation			25 mm mineral wool	
Filter: exhaust			G4	
intake			F7 (EU7)	
Duct connection diameter, [mm]	∅ 150	∅ 160	∅ 150	∅ 160
Weight, [kg]	38			40
Recuperation efficiency			up to 90%	
Heat exchanger type			counter-flow	
Heat exchanger material			polystyrene	

### Technical data:

	VUT 400 EH EC	VUT 400 WH EC	VUT 600 EH EC	VUT 600 WH EC
Unit supply voltage [V / 50 Hz]	1~ 230		1~ 230	
Maximum fan power [W]	2pcs. x 175		2pcs. x 175	
Fan current [A]	2pcs. x 1,3		2pcs. x 1,3	
Electric heater capacity [kW]	4,0	-	4,0	-
Electric heater current [A]	17,4	-	17,4	-
Number of water (glycol) coil rows	-	2	-	2
Total power of the unit [kW]	4,35	0,35	4,35	0,35
Total current of the unit [A]	20,0	2,6	20,0	2,6
Air capacity [m³/h]	400		600	550
RPM	1340		2150	
Noise level at 3m [dB[A]]	28-47	28-47	28-47	28-47
Operating temperature [°C]	-25 up to +60		-25 up to +60	
Casing material	aluzink		aluzink	
Insulation	25 mm mineral wool		25 mm mineral wool	
Filter: exhaust	G4		G4	
intake	F7 (EU7)		F7 (EU7)	
Duct connection diameter, [mm]	∅ 200		∅ 200	
Weight, [kg]	38	40	38	40
Recuperation efficiency	up to 90%		up to 90%	
Heat exchanger type	counter-flow		counter-flow	
Heat exchanger material	polystyrene		polystyrene	

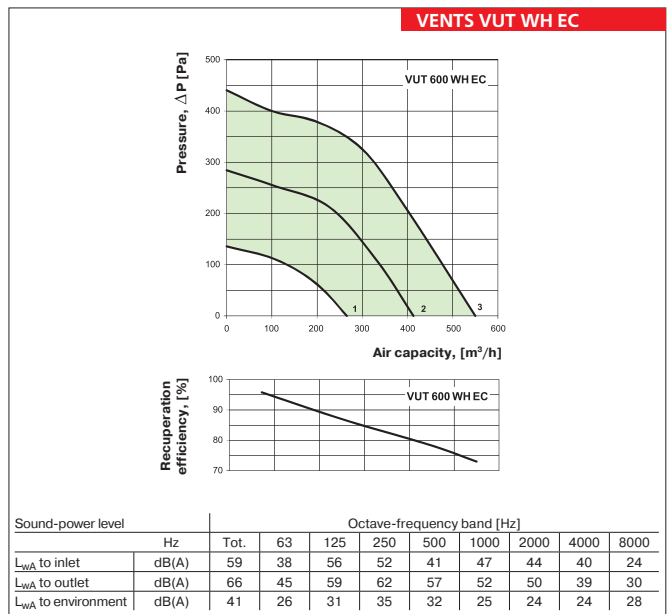
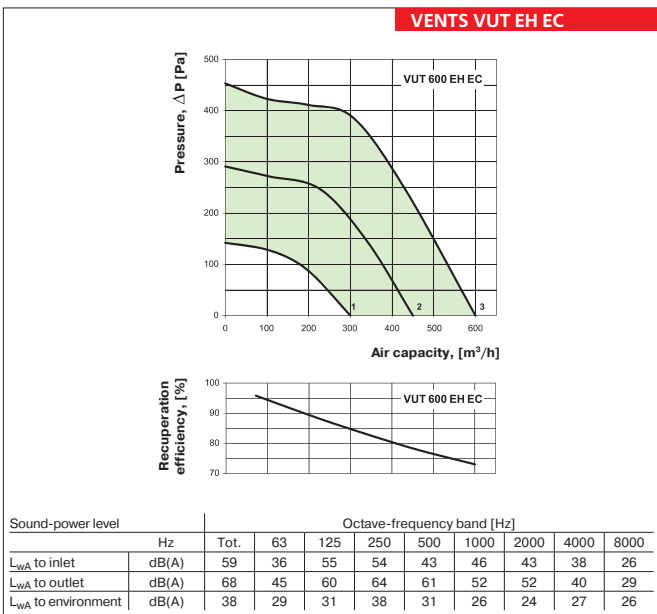
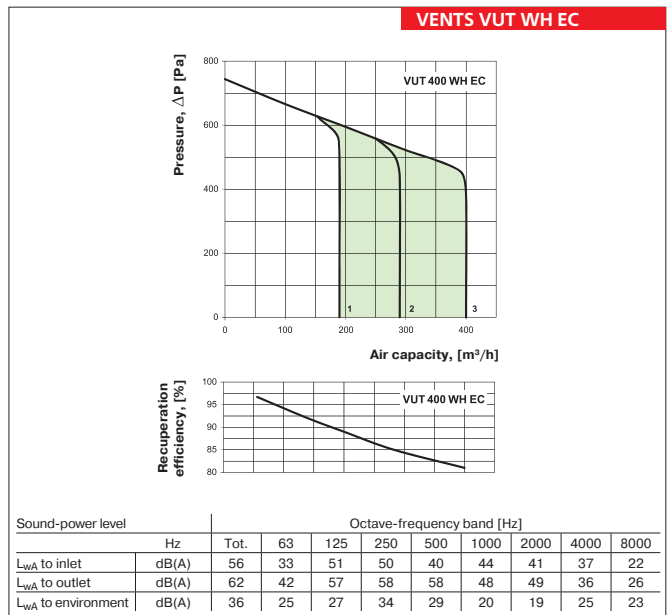
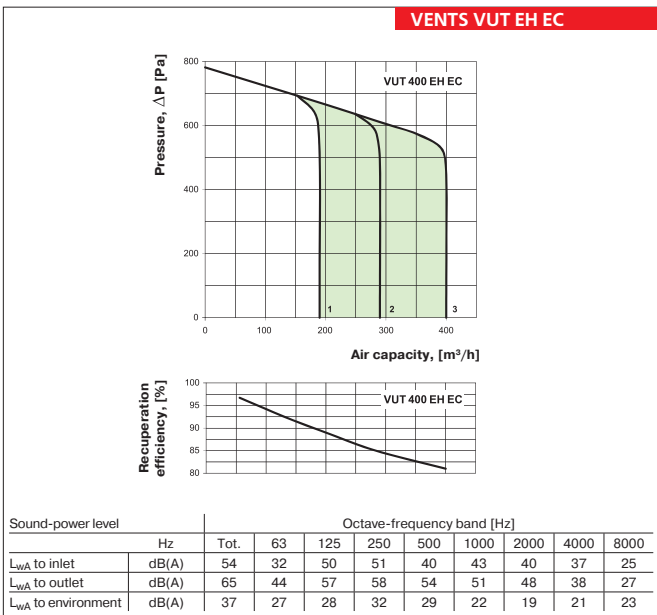
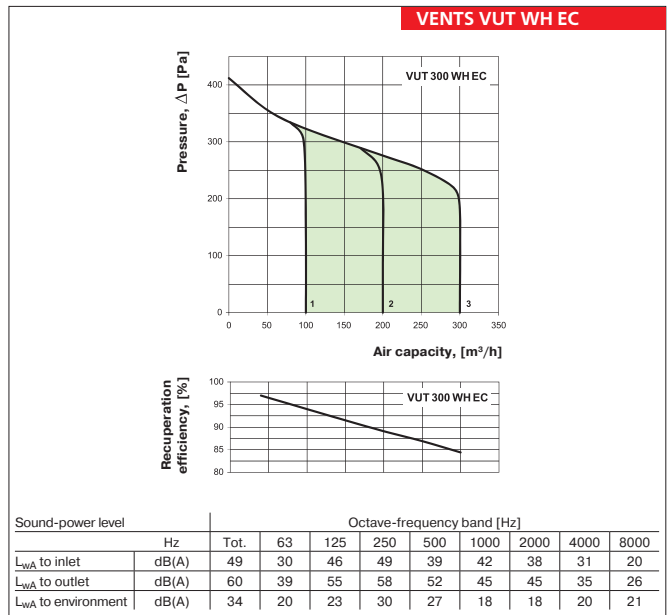
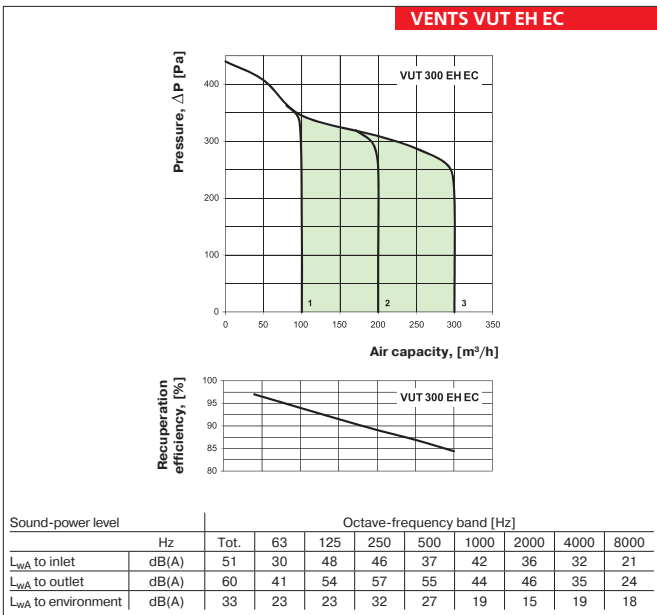

VENTS  
VUT EH EC /  
WH EC  
AIR HANDLING UNIT WITH  
HEAT RECOVERY SERIES

## Hot water coil parameters:

VENTS VUT WH EC

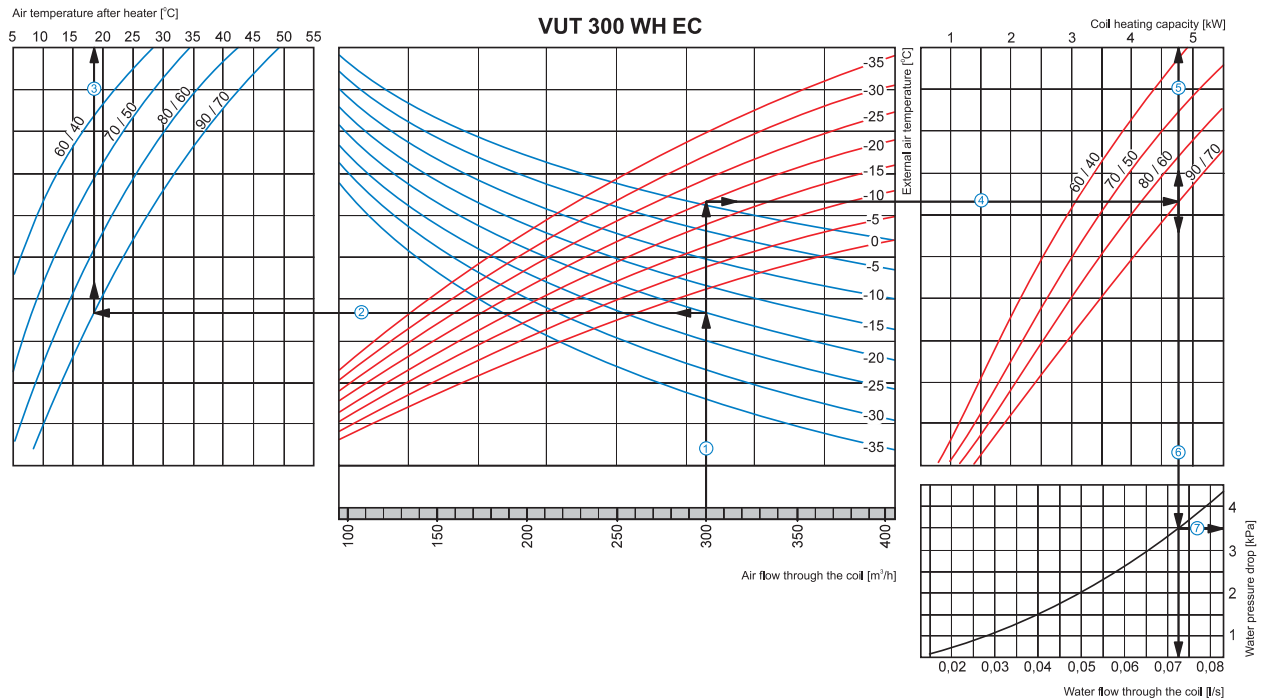

### How to use water heater diagrams

System Parameters: Air flow = 300 m³/h. Outside air temperature = -20°C. Water temperature (in/out) = 90/70 °C.

- Supply air temperature. prolong the line of air flow (e.g., 300 m³/h) ① up to the point where it crosses the outside air temperature (blue curve, e.g. -20°C); then draw a horizontal line ② from this point to the left till crossing water in/out temperature curve (e.g. 90/70 °C). From this point draw a vertical line ③ to the supply air temperature axis on top of the graphic (+18°C).
- Heating coil capacity. Prolong the line ① up to the point where it crosses the outside air temperature (e.g. -20°C, red curve) and draw a horizontal line ④ from this point to the right until it crosses water in/out temperature curve (e.g., 90/70 °C), from here draw a vertical line ⑤ up to the scale representing the heating coil capacity (4.75 kW).
- Water flow. Prolong the line ⑤ down to water flow axis at the bottom of the graphic ⑥ (0.072 l/s).
- Water pressure drop. Draw the line ⑦ from the point where the line ⑥ crosses the black curve to the pressure drop axis. (3.5 kPa).

VENTS VUT WH EC

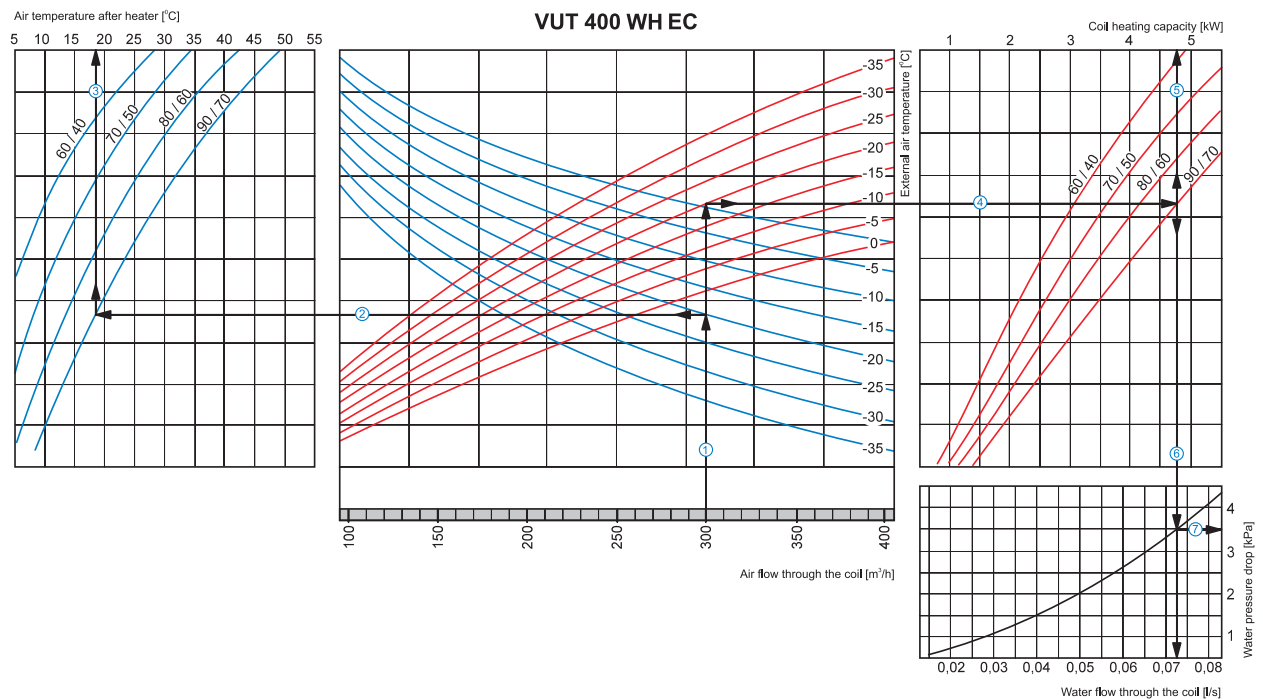

### How to use water heater diagrams

System Parameters: Air flow = 300 m³/h. Outside air temperature = -20°C. Water temperature (in/out) = 90/70 °C.

- Supply air temperature. prolong the line of air flow (e.g., 300 m³/h) ① up to the point where it crosses the outside air temperature (blue curve, e.g. -20°C); then draw a horizontal line ② from this point to the left till crossing water in/out temperature curve (e.g. 90/70 °C). From this point draw a vertical line ③ to the supply air temperature axis on top of the graphic (+18°C).
- Heating coil capacity. Prolong the line ① up to the point where it crosses the outside air temperature (e.g. -20°C, red curve) and draw a horizontal line ④ from this point to the right until it crosses water in/out temperature curve (e.g., 90/70 °C), from here draw a vertical line ⑤ up to the scale representing the heating coil capacity (4.75 kW).
- Water flow. Prolong the line ⑤ down to water flow axis at the bottom of the graphic ⑥ (0.072 l/s).
- Water pressure drop. Draw the line ⑦ from the point where the line ⑥ crosses the black curve to the pressure drop axis. (3.5 kPa).

Hot water coil parameters:

VENTS VUT WH EC

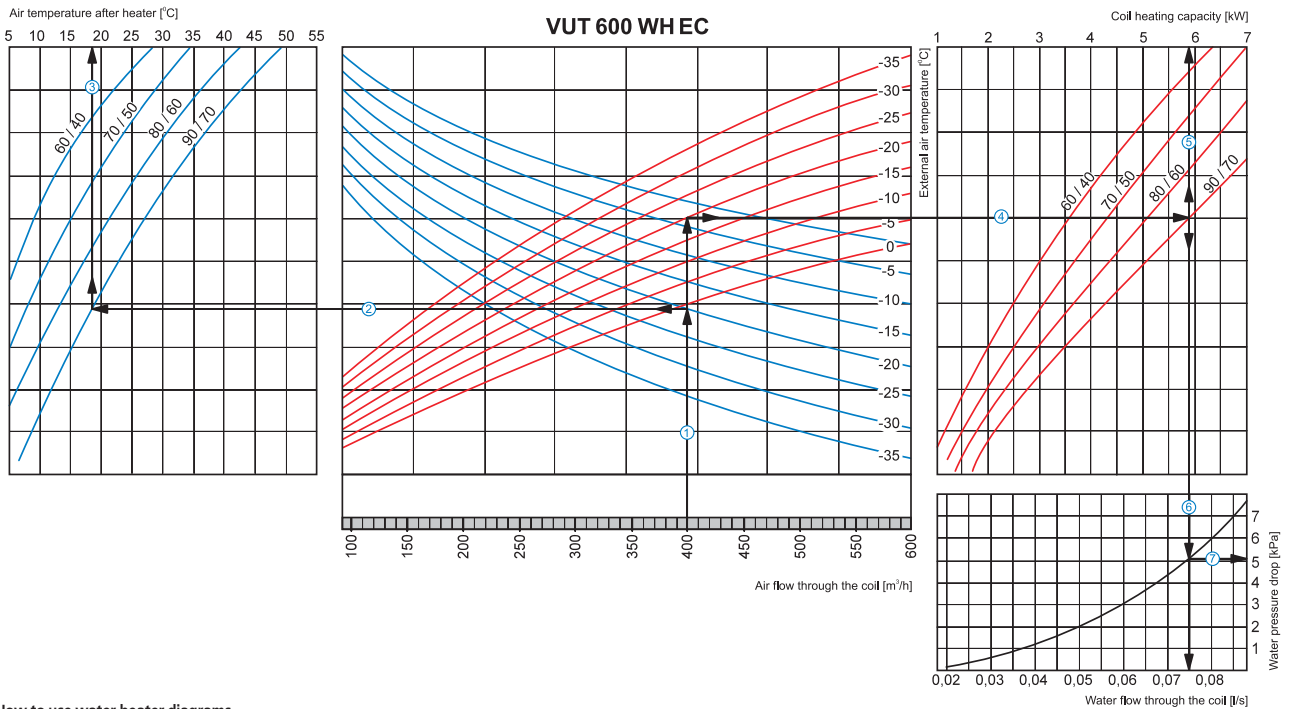

How to use water heater diagrams

System Parameters: Air flow = 400 m³/h. Outside air temperature = -20°C. Water temperature (in/out) = 90/70 °C

- Supply air temperature. prolong the line of air flow (e.g., 400 m³/h) ① up to the point where it crosses the outside air temperature (blue curve, e.g. -20°C); then draw a horizontal line ② from this point to the left till crossing water in/out temperature curve (e.g. 90/70 °C). From this point draw a vertical line ③ to the supply air temperature axis on top of the graphic (+18°C).
- Heating coil capacity. Prolong the line ① up to the point where it crosses the outside air temperature (e.g. -20°C, red curve) and draw a horizontal line ④ from this point to the right until it crosses water in/out temperature curve (e.g., 90/70 °C), from here draw a vertical line ⑤ up to the scale representing the heating coil capacity (5.9 kW).
- Water flow. Prolong the line ⑤ down to water flow axis at the bottom of the graphic ⑥ (0.075 l/s).
- Water pressure drop. Draw the line ⑦ from the point where the line ⑥ crosses the black curve to the pressure drop axis. (5.1 kPa).

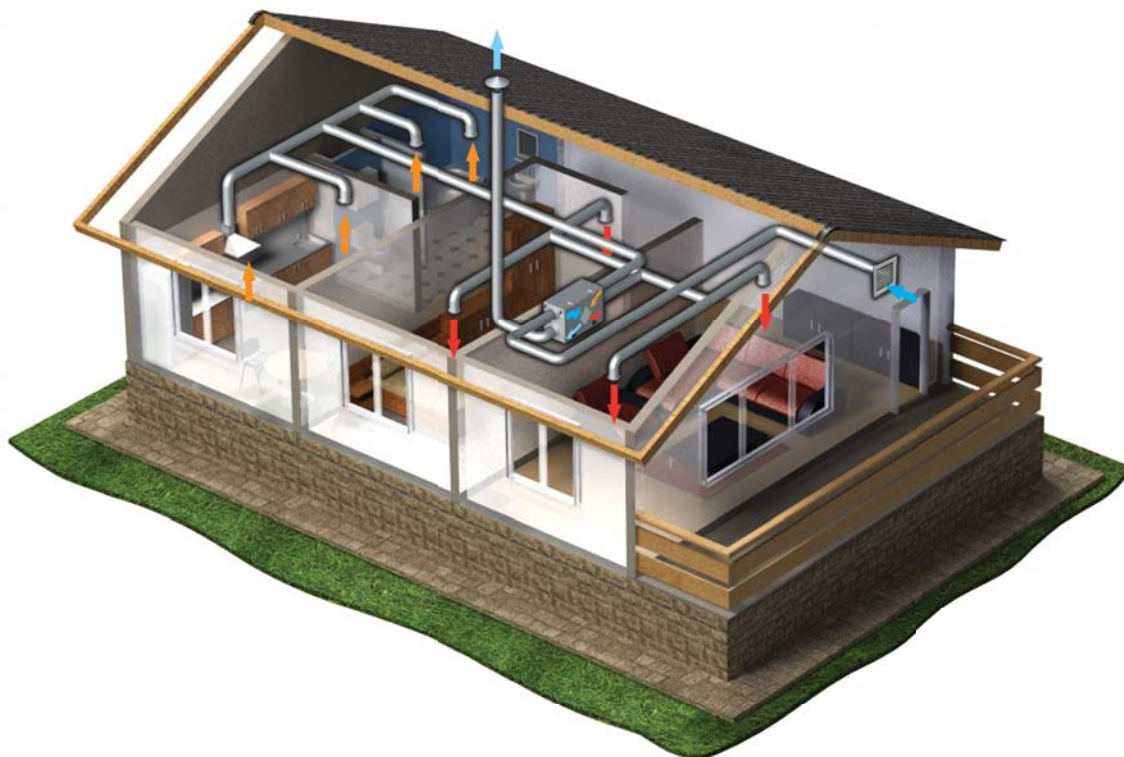

VUT EH EC ventilation and air exchange example in the cottage.

VENTS  
VUT EH EC /  
WH EC

AIR HANDLING UNIT WITH  
HEAT RECOVERY SERIES



Series  
**VENTS VUT PE EC**



Series  
**VENTS VUT PW EC**



Ceiling mounted energy saving Air Handling Units (AHU) with the air capacity up to **4000 m<sup>3</sup>/h** and the heat exchanger efficiency up to 90% in the sound- and heat-insulated casing with the electric heater.

Ceiling mounted Energy saving Air Handling Units (AHU) with the air capacity up to **3800 m<sup>3</sup>/h** and the heat exchanger efficiency up to 90% in the sound- and heat-insulated casing with the water heater.

■ **Description**

Air handling unit VUT PE EC with the electric heater and VUT PW EC with the water heating coils are the complete ventilation units designed to provide both supply and exhaust ventilation with air filtration and extract air removal. The exhaust air energy is used to heat up the supply fresh air through the plate heat exchanger.

Designed for ventilation and conditioning systems for various premises requiring economic solution and controllable air exchange. EC-motors reduce energy consumption by 1.5-3 times and ensure high efficiency and low noise level at the same time. All the models are compatible with 160 (150), 200, 250, 315 и 400 mm round ducts.

■ **Modifications**

**VUT PE EC** – models with the electric heater.

**VUT PW EC** – models with water heating coils.

■ **Casing**

The casing is made of aluzink with 20 mm mineral

wool internal heat and sound-insulating layer for VUT PE/PW 350, 600, 1000 units and 50 mm for VUT PE/PW 200, 3000 units.

■ **Filter**

Two incorporated G4 panel filters for supply and extract air ventilation are supplied with the unit.

■ **Motor**

VUT PE/PW EC units are equipped with exhaust and supply fans with backward curved blades powered by energy-saving direct current Electronically Commutated (EC) motors. These motors give up to 50% energy consumption economy as compared to standard AC motors. EC motors have built-in thermal overheating protection with automatic restart and enable smooth speed regulation from 0 to 100%. The ball bearings used with the EC motors are designed for at least 40 000 hours operation and are maintenance-free. Premium efficiency reaching 90% is an absolute privilege of the electronically commutated motor.

■ **Heat exchanger**

VUT 350, 600 and 1000 models are fitted with the counter-flow heat recovery element made of polystyrene. VUT 2000 and 3000 models are manufactured with the cross-flow air-to-air plate heat exchanger made of aluminum. All the units are equipped with the drain pan for condensate drainage.

■ **Heater**

The units are supplied with the water coils (VUT PW) or electric heater (VUT PE). If the external temperature is too low and/or heat energy transfer from the exhaust air is insufficient to heat up the supply air to the required temperature, the heater is turned automatically on. The control system regulates the heating power to keep the indoor temperature as set up by the user.

■ **Automation**

The unit is equipped with the built-in automation system with multifunctional control panel and graphic LCD indicator. The standard delivery set includes 10 m

**Designation key:** \_\_\_\_\_

Series	Rated air capacity, m <sup>3</sup> /h	Model	Heater type	Motor type
<b>VENTS VUT</b>	350; 600; 1000; 2000; 3000	<b>P</b> – suspended	<b>E</b> – electric heater; <b>W</b> – water heater	<b>EC</b> – electronically commutated synchronous motor

**Accessories**



page 240    page 240    page 280    page 294    page 296    page 305

**Offered options to the units**



page 213    page 213



wire for connection to the control panel. To prevent the heat exchanger freezing the icing electronic protection is applied. It includes the by-pass damper and the heater. The by-pass damper is opened as the temperature sensor requires to let the air flow pass through the heat exchanger through the by-pass duct. During the heat exchanger defrost cycle the supply air is warmed up in the heater up to the required temperature. During the defrosting process the warm exhaust air warms the heat exchanger. After that the by-pass damper closes again, the heater is switched off, supply air warms up again through the heat exchanger and the unit continues operating under rated conditions.

**VUT PE (EC) control and protection functions**

- ▶ safe start-up and shutdown of the unit;
- ▶ setting and maintaining the desired temperature of the supply air with the control panel;
- ▶ motor speed control and regulation of the unit air capacity accordingly by means of the control panel;
- ▶ control of the external intake and exhaust air damper actuators;
- ▶ working-out the required patterns while the unit start-up and shutdown;

- ▶ programming daily and weekly schedules by user;
- ▶ active electric heating elements overheating protection;
- ▶ disabling electric heater operation when the motor is not running;
- ▶ two thermostats for electric heater over-heating protection;
- ▶ automatic switch ensuring the short circuit protection of the automation system;
- ▶ controlling filter clogging.

**General description of VUT PW (EC) control system**

The unit is equipped with the built-in automatic control and monitoring system.

The control unit performs the following functions:

- ▶ safe start-up and shutdown of the unit;
- ▶ supply air temperature control by means of actuating three-way valve regulating the feed of the heat medium into the water coils;
- ▶ water (glycol) heating coils freezing protection as the leaving air temperature and leaving heat medium temperature sensors require;
- ▶ control of the heat exchanger by-pass actuator;
- ▶ control of the of external circulation pump

installed on the heat medium entering into the water coils;

- ▶ heat exchanger freezing protection;
- ▶ control of the supply and exhaust fans;
- ▶ air clogging control according to engine hours;
- ▶ control of the external intake and exhaust air damper actuators.

Air handling unit is equipped with the remote control panel that provides:

- ▶ starting-up/shutdown of the ventilation unit;
- ▶ setting the required air flow;
- ▶ setting the required supply air temperature;
- ▶ displaying the temperature in the room;
- ▶ failure (emergency) alarm indication.

**Mounting**

Air handling unit is suspended to the ceiling. The unit can be mounted either in service spaces or in main premises above the suspended ceiling, in the pocket or the unit can be placed directly in the room. Mounting in any position shall provide the correct condensate drainage. Access for the unit maintenance and filter cleaning shall be provided through the side panels.

**Unit overall dimensions:**

Type	Dimensions, [mm]											Figure №
	∅D	B	B1	B2	B3	B4	H	H1	L	L1	L2	
VUT 350 PE EC	160	485	415	596	132,5	220	285	130	1238	1286	948	1
VUT 600 PE EC	199	827	711	-	294	345	283	120	1238	1286	-	2
VUT 1000 PE EC	249	1350	1215	607,5	430	655	317	143	1346	1395	-	2
VUT 2000 PE EC	314	1050	915	457,5	247	575	750	375	1360	1408	-	2
VUT 3000 PE EC	399	1265	1130	565	297	632,5	830	415	1595	1643	-	2
VUT 600 PW EC	199	827	711	-	294	345	283	120	1238	1286	-	2
VUT 1000 PW EC	249	1350	1215	607,5	430	655	317	143	1346	1395	-	2
VUT 2000 PW EC	314	1050	915	457,5	247	575	750	375	1360	1408	-	2
VUT 3000 PW EC	399	1265	1130	565	297	632,5	830	415	1595	1643	-	2

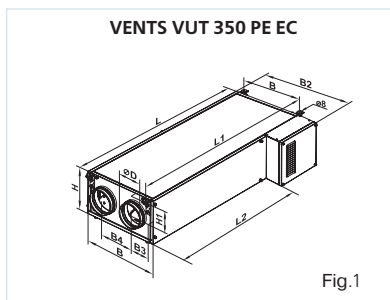

Fig.1

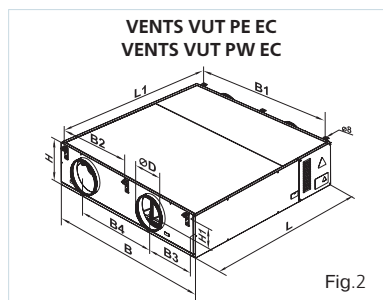

Fig.2

VENTS  
 VUT PE EC /  
 PW EC  
 AIR HANDLING UNIT WITH  
 HEAT RECOVERY SERIES

## AIR HANDLING UNITS WITH HEAT RECOVERY

### Technical data:

	VUT 350 PE EC	VUT 600 PE EC	VUT 600 PW EC
Unit supply voltage [V / 50 Hz]	1~ 230	1~ 230	
Maximum fan power [W]	2pcs. x 51	2pcs. x 100	
Fan current [A] (Supply voltage of the fan with EC motor)	2pcs. x 1,2 (48V)	2pcs. x 2,4 (48V)	
Electric heater capacity [kW]	1,5	2,0	-
Electric heater current [A]	6,5	8,7	-
Total power of the unit [kW]	1,502	2,20	0,20
Total current of the unit [A]	7,05	9,76	1,06
Air capacity [m <sup>3</sup> /h]	400	700	600
RPM	2950	3150	
Noise level at 3m [dB[A]]	48	53	
Operating temperature [°C]	-25 up to +40	-25 up to +60	
Casing material	aluzink	aluzink	
Insulation	20 mm mineral wool	20 mm mineral wool	
Filter: exhaust	G4	G4	
intake	G4	G4	
Duct connection diameter, [mm]	∅ 160 (150)*	∅ 200	
Weight, [kg]	65	75	77
Recuperation efficiency	up to 90%	up to 90%	
Heat exchanger type	counter-flow	counter-flow	
Heat exchanger material	polystyrene	polystyrene	

\* in case of reducer ∅ 160/150 mm.

### Technical data:

	VUT 1000 PE EC	VUT 1000 PW EC	VUT 2000 PE EC	VUT 2000 PW EC
Unit supply voltage [V / 50 Hz]	1~ 230		3~ 400	1~ 230
Maximum fan power [W]	2pcs. x 135		2pcs. x 420	
Fan current [A] (Supply voltage of the fan with EC motor)	2pcs. x 2,8 (48V)		2pcs. x 2,5 (230V)	
Electric heater capacity [kW]	3,3	-	12,0	-
Electric heater current [A]	14,3	-	17,4	-
Total power of the unit [kW]	3,57	0,27	12,84	0,84
Total current of the unit [A]	15,53	1,23	22,4	5
Air capacity [m <sup>3</sup> /h]	1100	1000	2000	1950
RPM	2645		2920	
Noise level at 3m [dB[A]]	52		58	
Operating temperature [°C]	-25 up to +60		-25 up to +40	
Casing material	aluzink		aluzink	
Insulation	20 mm mineral wool		50 mm mineral wool	
Filter: exhaust	G4		G4	
intake	G4		G4	
Duct connection diameter, [mm]	∅ 250		∅ 315	
Weight, [kg]	95	98	190	194
Recuperation efficiency	up to 90%		up to 75%	
Heat exchanger type	counter-flow		cross-flow	
Heat exchanger material	polystyrene		aluminum	

**Technical data:**

	VUT 3000 PE EC	VUT 3000 PW EC
Unit supply voltage [V / 50 Hz]	3~ 400	
Maximum fan power [W]	2pcs. x 990	
Fan current [A] (Supply voltage of the fan with EC motor)	2pcs. x 1,7 (400V)	
Electric heater capacity [kW]	18,0	-
Electric heater current [A]	26,0	-
Total power of the unit [kW]	19,98	1,98
Total current of the unit [A]	29,4	3,4
Air capacity [m³/h]	4000	3800
RPM	2580	
Noise level at 3m [dB[A]]	59	
Operating temperature [°C]	-25 up to +50	
Casing material	aluzink	
Insulation	50 mm mineral wool	
Filter: exhaust	G4	
intake	G4	
Duct connection diameter, [mm]	ø400	
Weight, [kg]	290	295
Recuperation efficiency	up to 75%	
Heat exchanger type	cross-flow	
Heat exchanger material	aluminum	

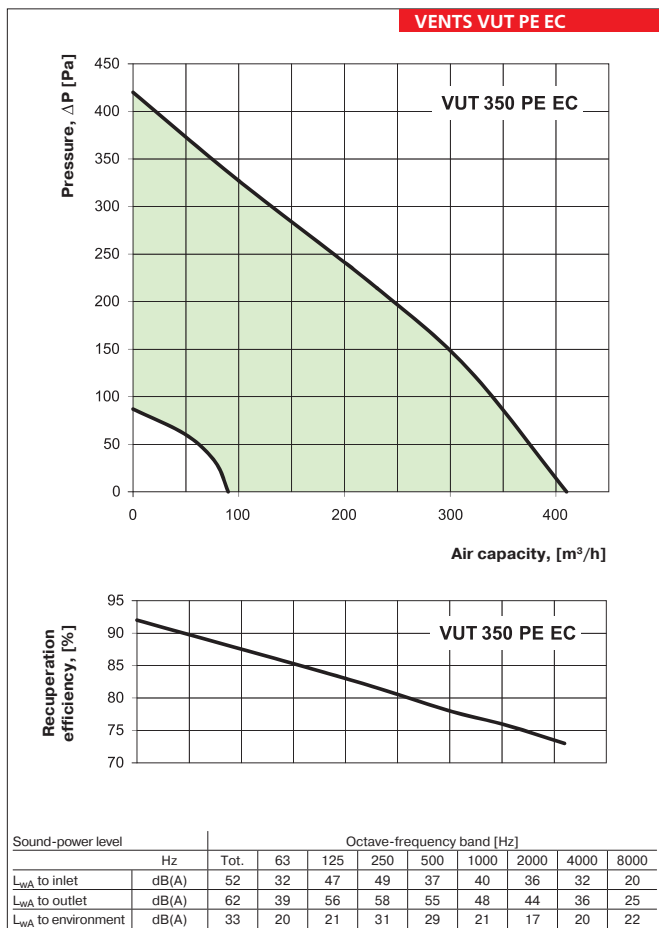

**Accessories to air handling units:**

Type	Replaceable filter	
	Intake (pocket type)	Exhaust (panel type)
VUT 350 PE EC	SFK 350 PE G4	SF 350 PE G4
VUT 600 PE EC	SFK 600 PE/PW G4	SF 600 PE/PW G4
VUT 1000 PE EC	SFK 1000 PE/PW G4	SF 1000 PE/PW G4
VUT 2000 PE EC	SF 2000 PE/PW G4	
VUT 3000 PE EC	SF 3000 PE/PW G4	
VUT 600 PW EC	SFK 600 PE/PW G4	SF 600 PE/PW G4
VUT 1000 PW EC	SFK 1000 PE/PW G4	SF 1000 PE/PW G4
VUT 2000 PW EC	SF 2000 PE/PW G4	
VUT 3000 PW EC	SF 3000 PE/PW G4	

VENTS  
 VUT PE EC /  
 PW EC  
 AIR HANDLING UNIT WITH  
 HEAT RECOVERY SERIES

VENTS VUT PE EC

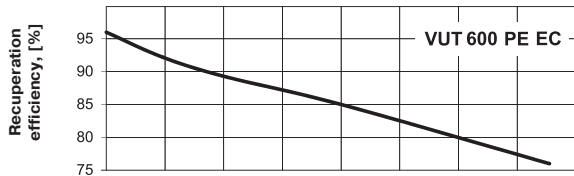
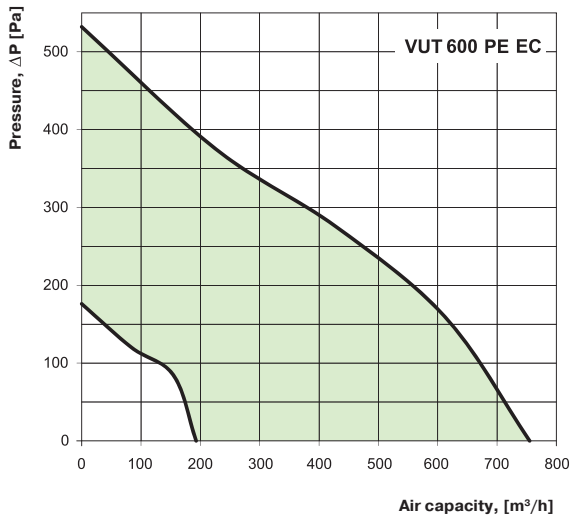

Sound-power level	Hz	Tot.	Octave-frequency band [Hz]							
			63	125	250	500	1000	2000	4000	8000
$L_{WA}$ to inlet	dB(A)	55	35	56	53	43	47	45	37	28
$L_{WA}$ to outlet	dB(A)	65	47	60	61	61	52	51	40	30
$L_{WA}$ to environment	dB(A)	39	30	30	39	33	23	24	26	28

VENTS VUT PW EC

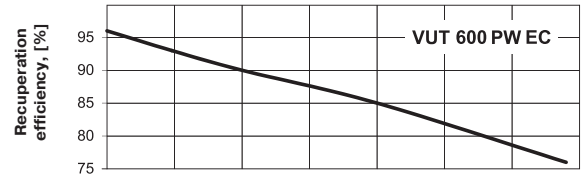
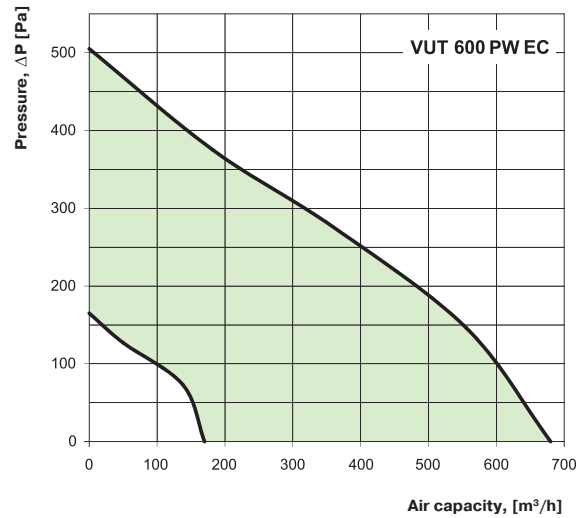

Sound-power level	Hz	Tot.	Octave-frequency band [Hz]							
			63	125	250	500	1000	2000	4000	8000
$L_{WA}$ to inlet	dB(A)	59	34	56	54	43	46	44	36	24
$L_{WA}$ to outlet	dB(A)	68	43	59	62	59	52	52	40	29
$L_{WA}$ to environment	dB(A)	38	29	27	39	33	23	23	24	24

VENTS VUT PE EC

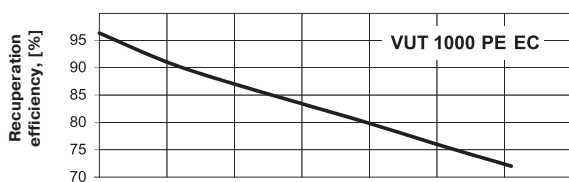
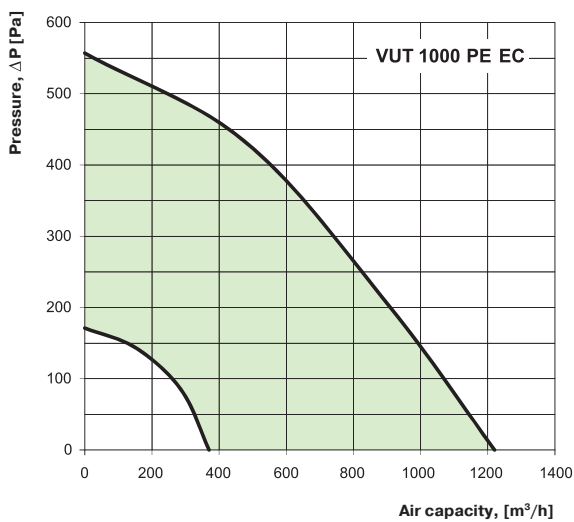

Sound-power level	Hz	Tot.	Octave-frequency band [Hz]							
			63	125	250	500	1000	2000	4000	8000
$L_{WA}$ to inlet	dB(A)	68	67	68	70	68	60	60	61	55
$L_{WA}$ to outlet	dB(A)	70	71	69	68	66	65	63	61	58
$L_{WA}$ to environment	dB(A)	45	57	56	47	52	42	38	34	35

VENTS VUT PW EC

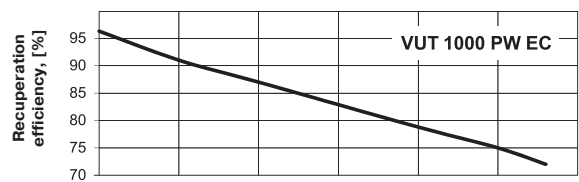
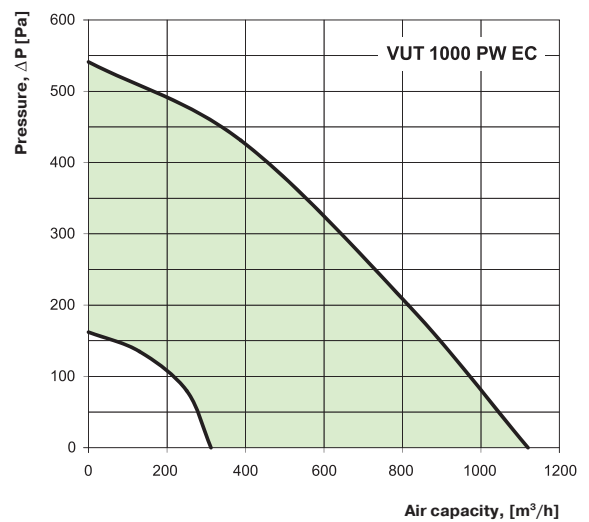

Sound-power level	Hz	Tot.	Octave-frequency band [Hz]							
			63	125	250	500	1000	2000	4000	8000
$L_{WA}$ to inlet	dB(A)	67	68	67	67	66	59	61	61	56
$L_{WA}$ to outlet	dB(A)	69	70	71	68	66	66	64	59	58
$L_{WA}$ to environment	dB(A)	47	58	52	47	53	40	41	35	35

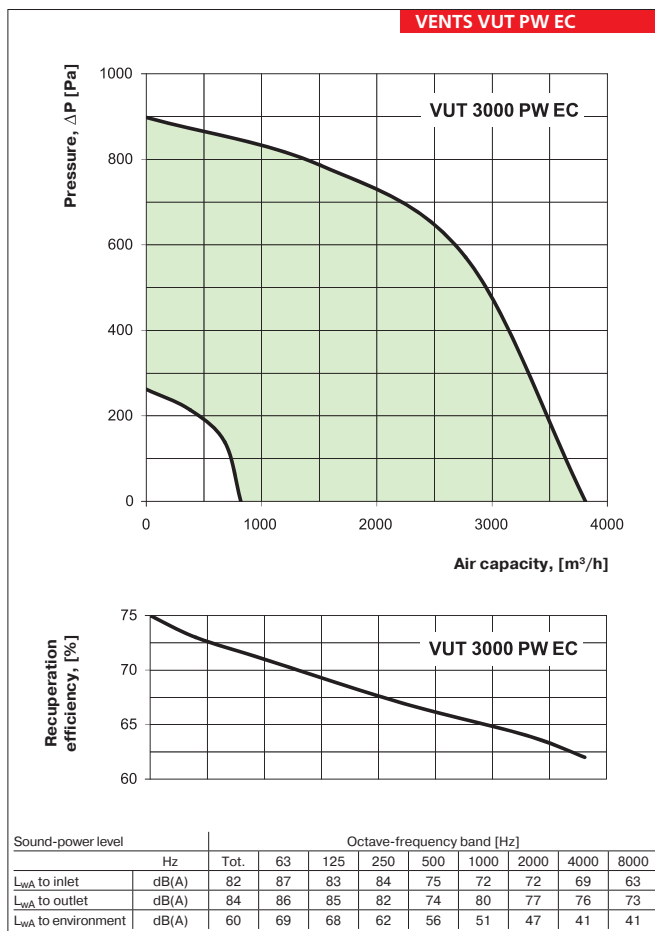
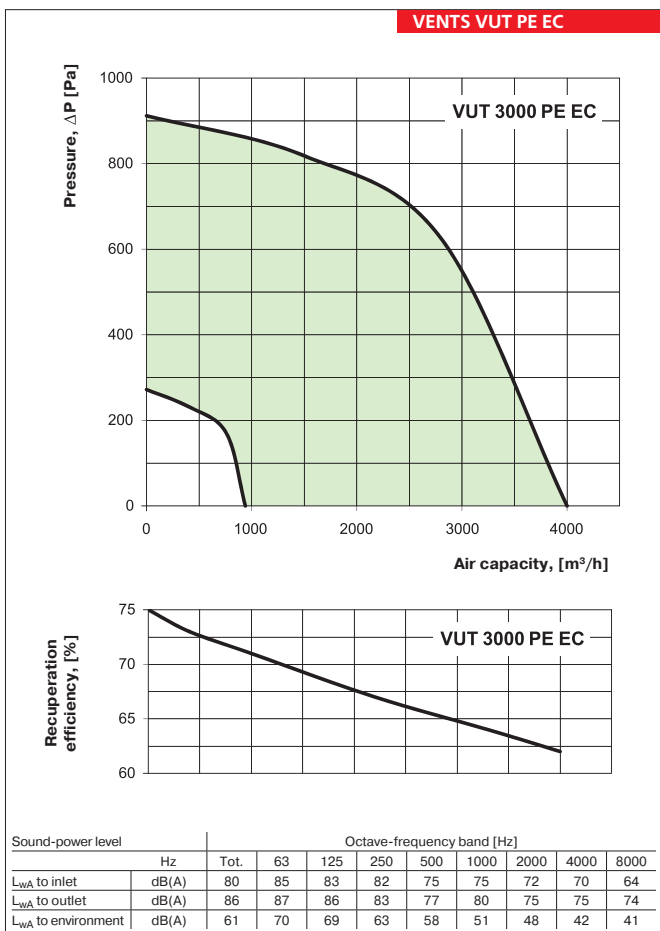
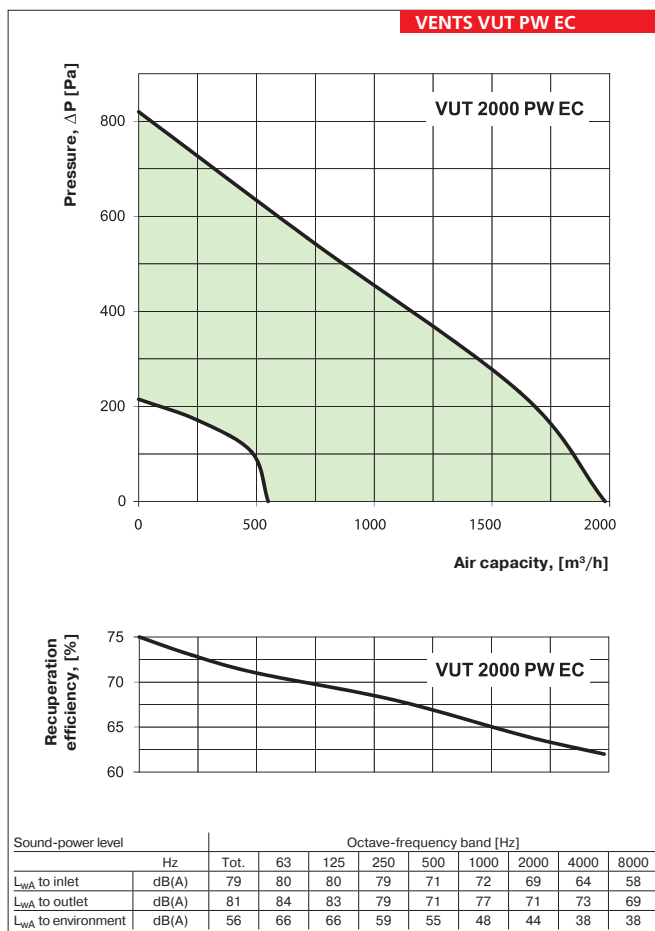
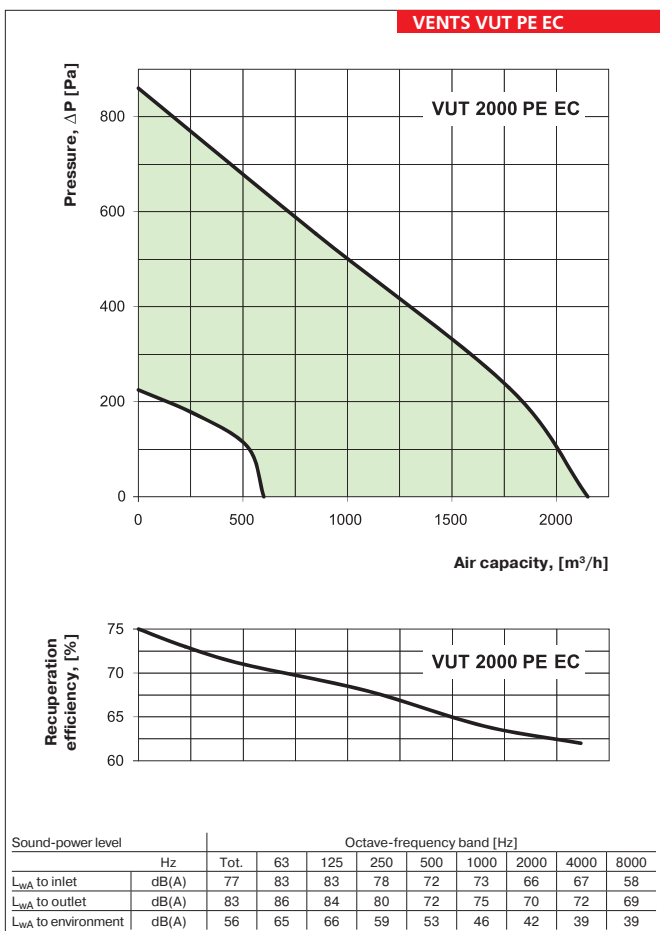

VENTS  
 AIR HANDLING UNIT WITH  
 VUT PE EC /  
 PW EC  
 HEAT RECOVERY SERIES

Hot water coil parameters:

VENTS VUT PW EC

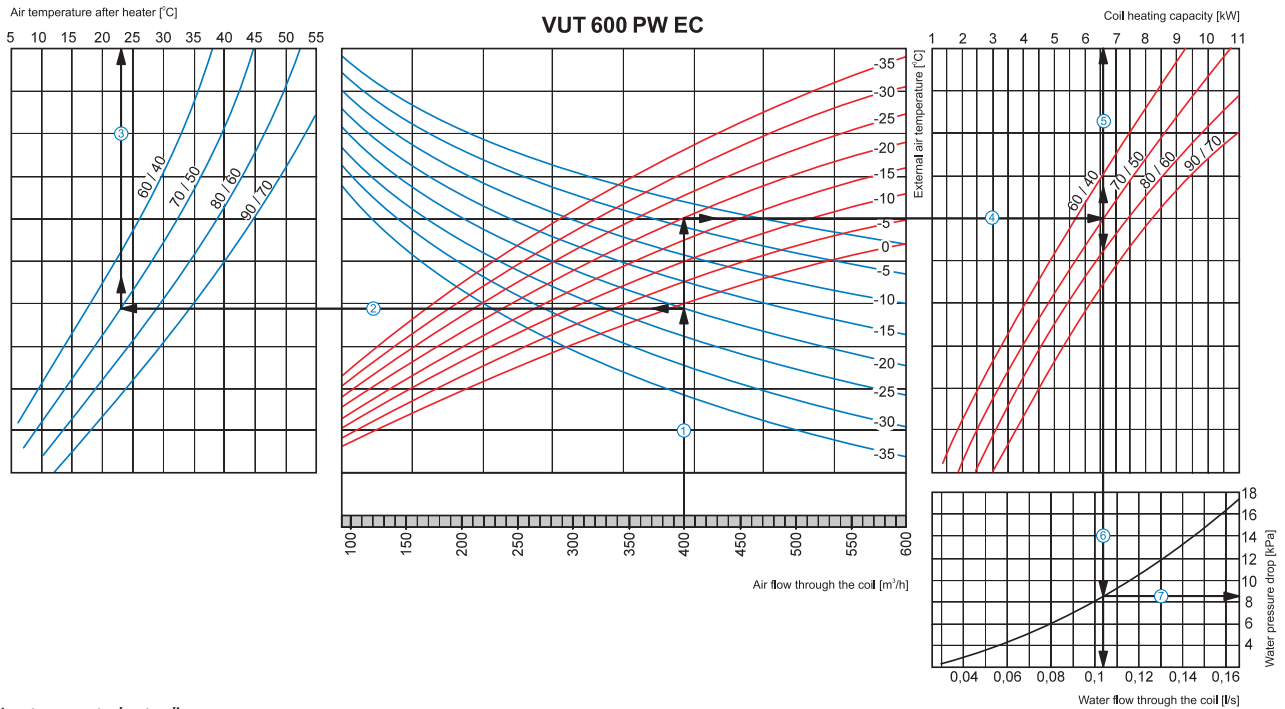

How to use water heater diagrams

System Parameters: Air flow = 400 m³/h. Outside air temperature = -20°C. Water temperature (in/out) = 70/50 °C.

- Supply air temperature. prolong the line of air flow (e.g., 400 m³/h) ① up to the point where it crosses the outside air temperature (blue curve, e.g. -20°C); then draw a horizontal line ② from this point to the left till crossing water in/out temperature curve (e.g. 70/50 °C). From this point draw a vertical line ③ to the supply air temperature axis on top of the graphic (+23°C).
- Heating coil capacity. Prolong the line ① up to the point where it crosses the outside air temperature (e.g. -20°C, red curve) and draw a horizontal line ④ from this point to the right until it crosses water in/out temperature curve (e.g., 70/50 °C), from here draw a vertical line ⑤ up to the scale representing the heating coil capacity (6.6 kW).
- Water flow. Prolong the line ⑤ down to water flow axis at the bottom of the graphic ⑥ (0.105 l/s).
- Water pressure drop. Draw the line ⑦ from the point where the line ⑥ crosses the black curve to the pressure drop axis. (8.5 kPa).

VENTS VUT PW EC

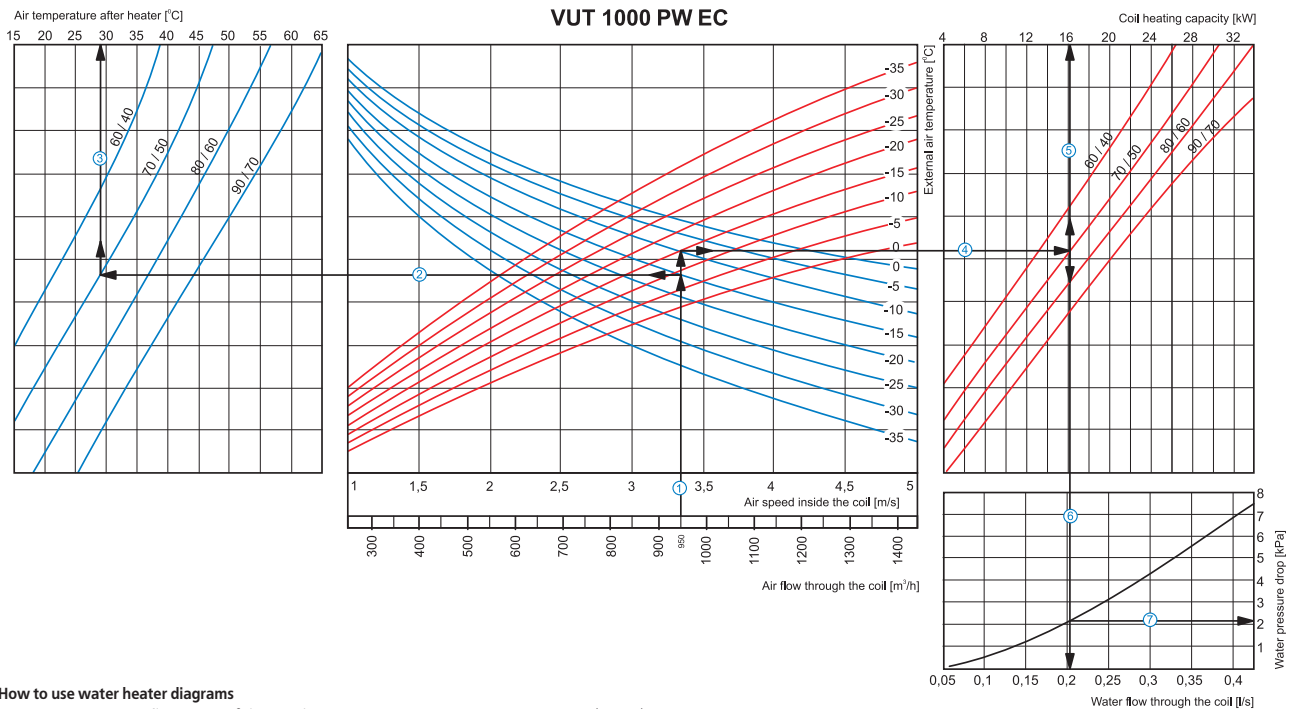

How to use water heater diagrams

System Parameters: Air flow = 950 m³/h. Outside air temperature = -15°C. Water temperature (in/out) = 70/50 °C.

- Air Speed. Starting from 950 m³/h on the air flow scale draw a vertical line ① till the air speed axis which makes about 3.35 m/s.
- Supply air temperature. prolong the line ① up to the point where it crosses the outside air temperature (blue curve, e.g. -15°C); then draw a horizontal line ② from this point to the left till crossing water in/out temperature curve (e.g. 70/50 °C). From this point draw a vertical line ③ to the supply air temperature axis on top of the graphic (+29°C).
- Heating coil capacity. Prolong the line ① up to the point where it crosses the outside air temperature (e.g. -15°C, red curve) and draw a horizontal line ④ from this point to the right until it crosses water in/out temperature curve (e.g., 70/50 °C), from here draw a vertical line ⑤ up to the scale representing the heating coil capacity (16.0 kW).
- Water flow. Prolong the line ⑤ down to water flow axis at the bottom of the graphic ⑥ (0.21 l/s).
- Water pressure drop. Draw the line ⑦ from the point where the line ⑥ crosses the black curve to the pressure drop axis. (2.1 kPa).



**Hot water coil parameters:**

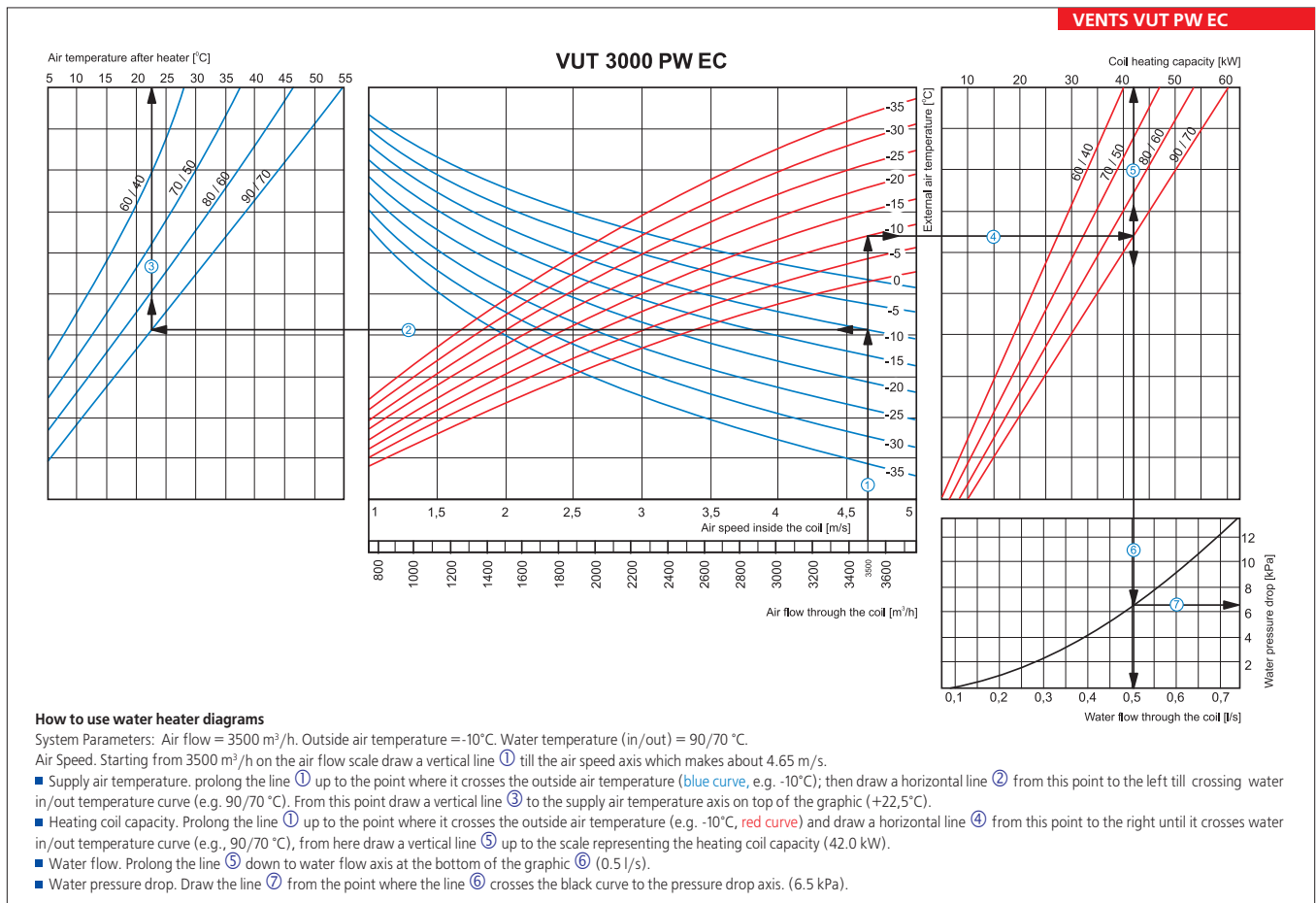
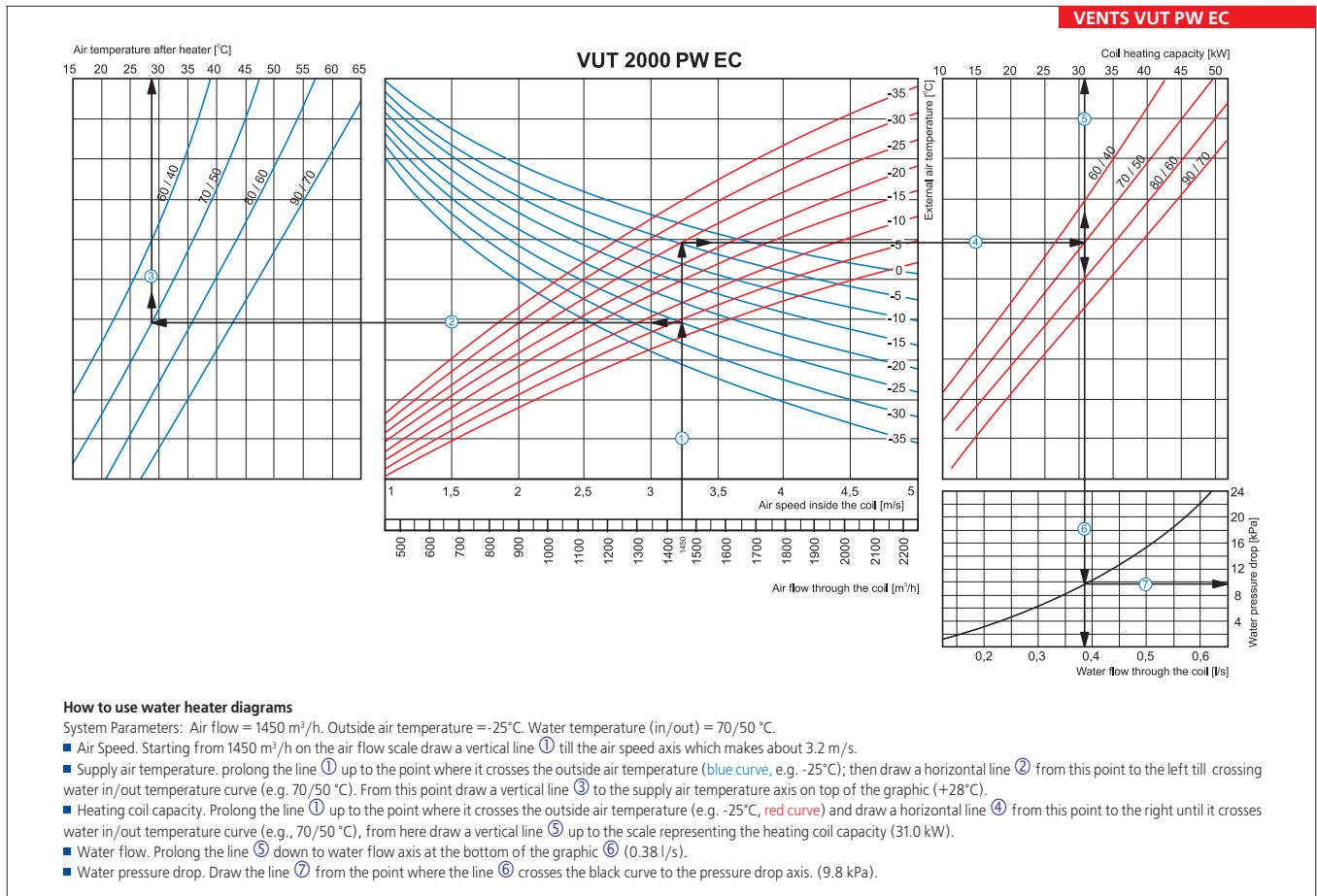

VENTS  
AIR HANDLING UNIT WITH  
HEAT RECOVERY SERIES  
VUT PE EC /  
PW EC

# ENERGY-SAVING IN-LINE UNITS



**Energy-saving units X-vent are the best solution for ventilation and conditioning systems!**

- Do you have limited space in your room?
  - Ventilating chambers are not provided?
    - Do you want to conceal the whole ventilation system under the suspended ceiling?
    - Do you need reasonable and energy-saving solution?

## In this case X-vent in-line units are the best solution!

Based on in-line X-vent units you can arrange both complex and simple ventilation and conditioning systems. X-vent units are designed for arranging any application: air supply, air exhaust, air handling with heat recovery.

### Advantages of in-line X-vent units:

- ▶ Complex solution;
- ▶ Complete range of products;
- ▶ Small-sized and efficient;
- ▶ Easy mounting;
- ▶ Energy-saving technologies;
- ▶ Complex automation system included into equipment list;
- ▶ Low operating costs;
- ▶ Easy fan maintenance and filter removal;
- ▶ Long service life (at least 40 000 hours of continuous operation);
- ▶ High quality for the best price.

### Basic components of the in-line system:



**RRVAF**  
air flow regulating damper



**VKPF**  
radial fan



**PK**  
bend



**NKW**  
water coil



**OKW/OKF**  
water / direct-expansion air cooling coils



**VKP...EC**  
radial-flow fan with EC-motor

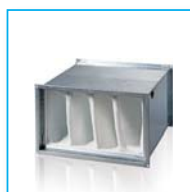

**FB and FBK**  
filters

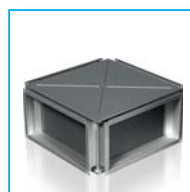

**PR**  
Plate heat exchanger



**SR**  
Silencer



**VVG**  
Flexible connector

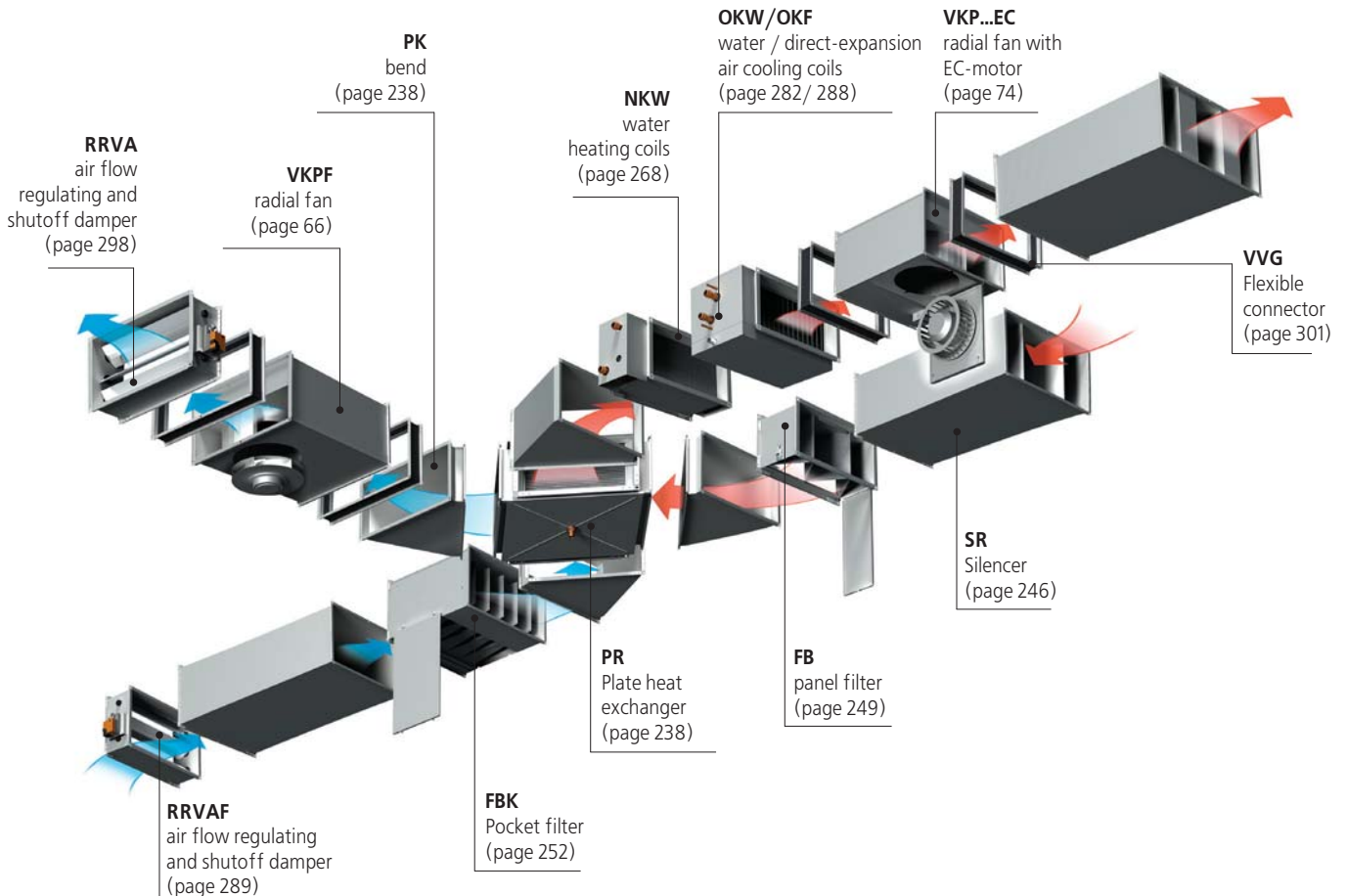
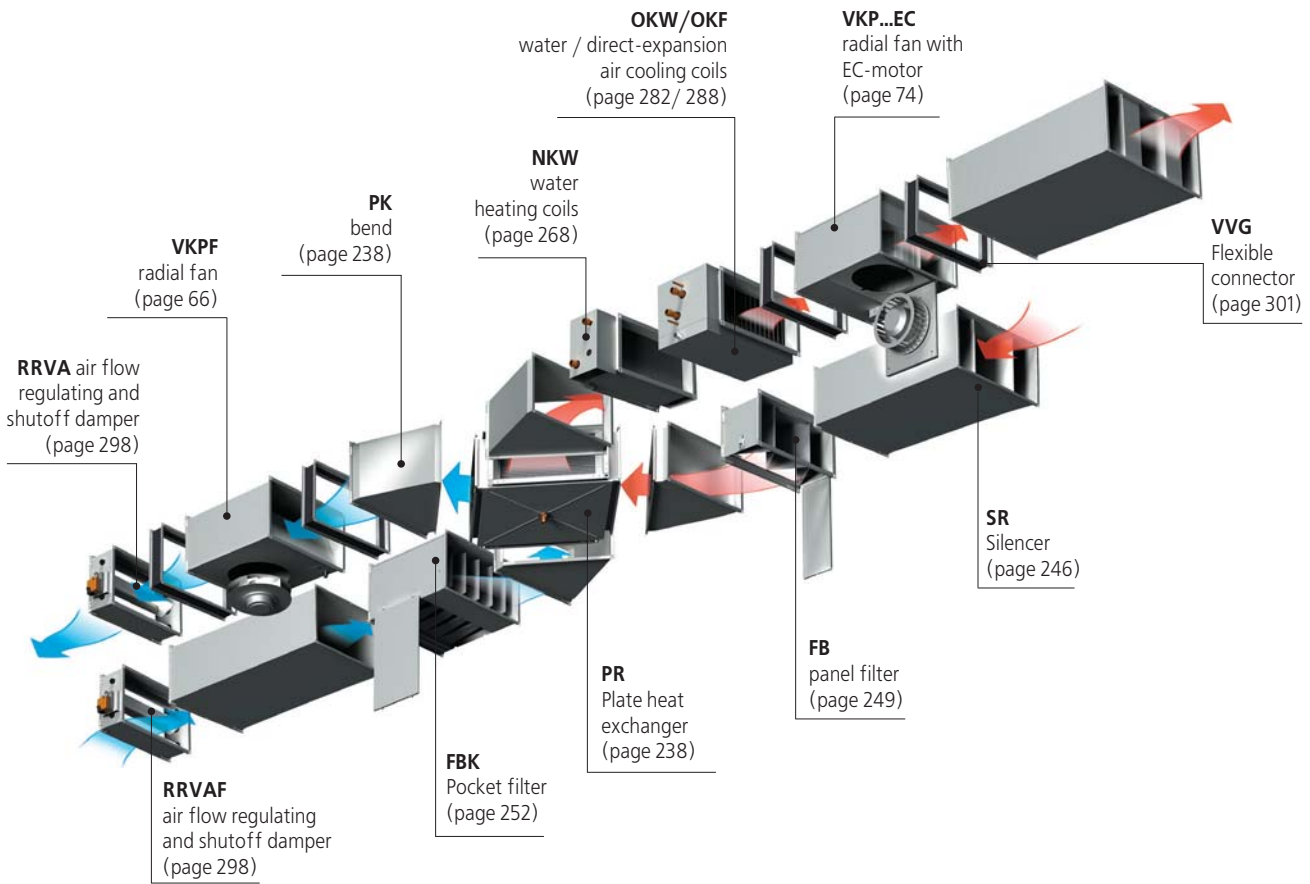

# AIR HANDLING UNITS

## AIR VENTS

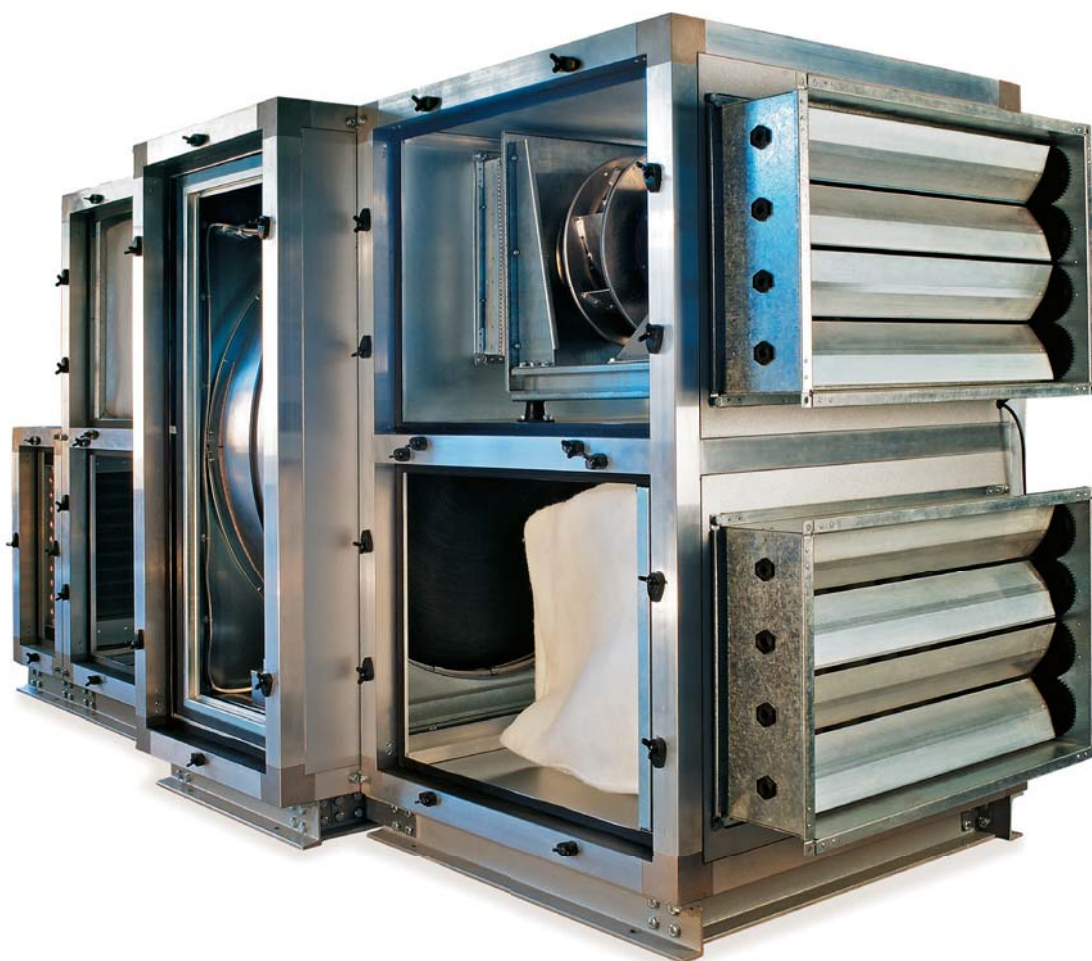



# airVENTS

## ■ Designation

AirVents air handling units are the complete ventilation units ensuring the supply air filtering and heating as well as removal of the extract air. Application varies from the office and bank premises, cinema halls, gyms and swimming pools to the hotels, residential premises, industrial workshops, stocks and supermarkets etc.

## ■ Standard sizes

Air handling units AirVents are available in 8 standard sizes for the air capacity from 2000 up to 35000 m<sup>3</sup>/h. Air handling units are available in left-side and right-side modifications. The service side is marked with respect to its location to air flow. It determines the position of the connecting pipes of water coils and condensate drainage.

## ■ Description

AirVents air handling units is a complex solution for a fully compact and packaged ventilation system. Modularity is the basic privilege of AirVents system. The modular air handling units consist of some functional sections that can be connected in any configurations to create the various complexity equipment upon the customer request in compliance with specific operating conditions.

Purely high quality components supplied by the leading world-wide manufacturers ensure the reliability of the whole complete unit. Energy-efficient automation as well as units and components contribute much to reducing energy consumption.

VENTS is the only company with complete production run of air handling units at one manufacturing facility.

## ■ Casing

The air handling unit frame consists of aluminium shapes connected together with aluminium angles on the mounting frame made of rolled steel to ensure the structure strength and stability. The air-tight casing with extra sealing consists of assembled double skinned aluzink panels internally filled with 50 mm mineral wool heat and sound-insulating layer.

### Effective ranges of air capacity for AirVents units:

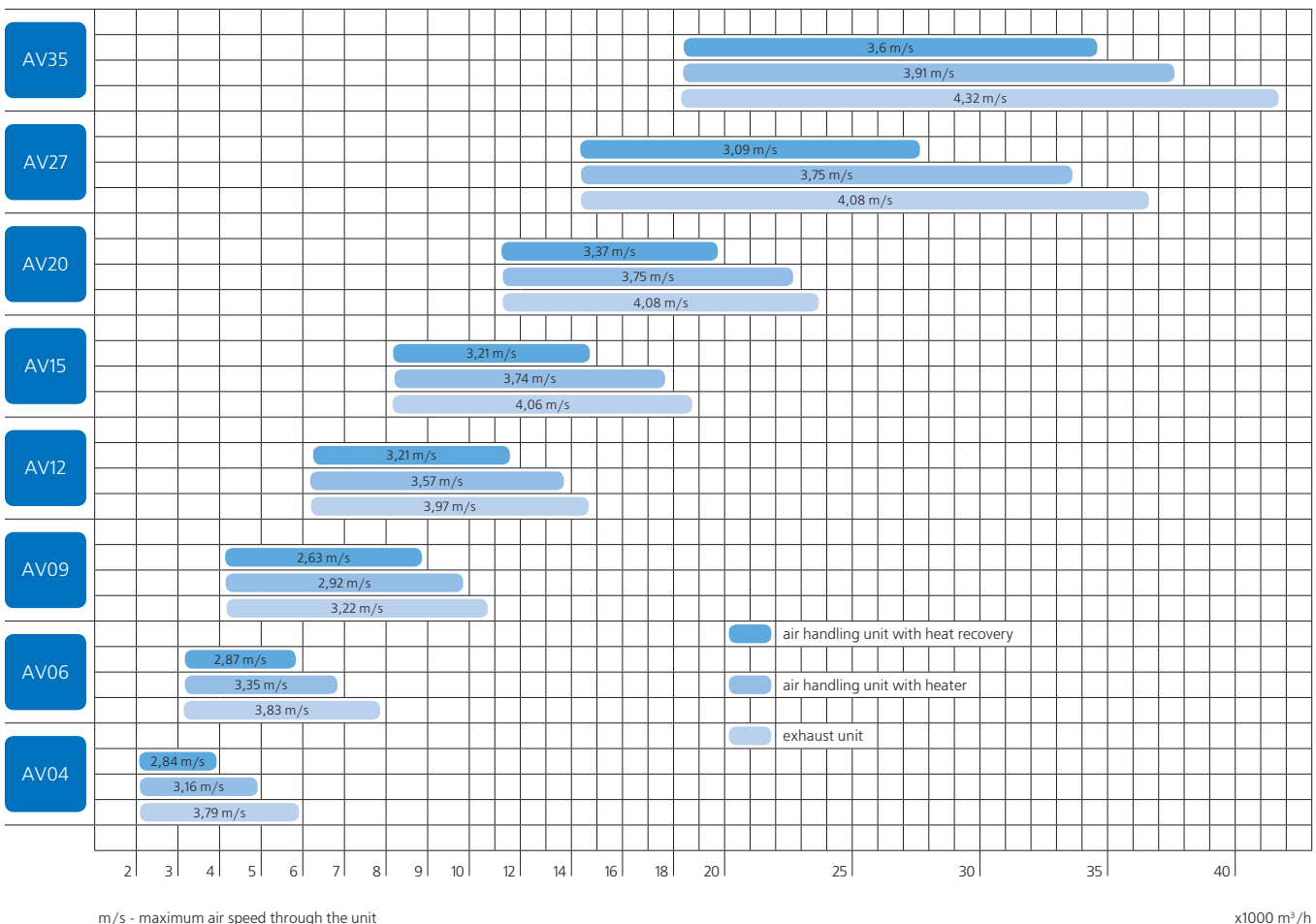

▶ Fan section



The fan section is the basic element of the air handling units. Centrifugal belt-driven cased fans and plug direct-driven fans are applied for AirVents air handling units. A cased fan is a double-inlet high-efficient belt-driven centrifugal fan in the sound-insulated casing. The fan impeller can be supplied with backward or forward curved blades. The fans are mounted on a rigid frames on rubber anti-vibration mounts specifically selected in compliance with the minimum vibration transmission requirements to the air handling unit casing. The fan is connected to the air handling unit through the flexible connector that excludes the vibration transmission to the unit casing.

◆ Heat exchanger section

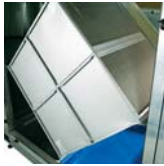

Heat exchanger section is designed for utilization of exhaust air heat. The units can be equipped with the plate heat exchanger or rotary heat exchanger. The cross-flow plate heat exchanger is made of aluminium plates that create ductwork system. The heat exchanger plates are sealed with elastic thermal sealant and fixed internally by means of fixing clamps. Such sealing ensures partition of air streams.



Rotor heat exchanger section consists of the belt driven rotary with the cellular structure due to the aluminium band. The heat exchanger is equipped with the efficient brush sealing around the rotor to minimize the air overflow.

The heat exchanger has either fixed or adjustable speed control type. The adjustable speed control is performed by means of built-in electronic controller that enables the smooth speed controlling and maintaining the best suitable temperature mode.

+ - Heater and coolers



The electric heater in the air handling units is applied to warm up the supply air. The casing is made of galvanized steel sheet and the heating elements are made of stainless steel with additional ribbing which increases the heat exchange surface area and heat transfer to incoming air. NK heaters are equipped with two overheating protection thermostats.



Water heating coils in air handling units are applied to warm up the supply air. The casing is made of galvanized steel sheet and the coils are made of copper tubes and the heat exchange surface is made of aluminium plates. Hot water with the temperature up to 150 °C serves as a heat medium. The connection of the water coils to the heat supply system can be performed by means of threading connection, flanges or welding. The water heating coils can be equipped with connecting pipes for temperature sensors for automatic icing protection.



The cooler in air handling units is applied for supply air cooling. This function is performed by water or direct expansion cooling coils which consist of copper tubes with additional aluminum ribbing. For marine climate application the heat exchangers with additional ribbing made of aluminum-magnesium alloy are available. The direct evaporation cooling coils are equipped with the built-in manifold header. The thermostatic expansion valve can be placed outside on the connected pipe. The unit is equipped with the drain pan for the condensate collection. Droplet separator can be installed to prevent the dropping liquid carrying away with the air stream.

Ⓜ Silencer section



The plate silencers in air handling units are applied for absorption of noise produced by the operating unit. The silencer sections are installed between the fan units and air inlet/outlet vent. The silencers consist of galvanized steel plates filled internally with sound-absorbing fire-resistant insulant with additional synthetic fiber protection. The noise absorbing plates have special covering to protect the noise-absorbing material:

1. Standard covering is applied for general-purpose ventilation systems.
2. Wear-resistant covering is for dry cleaning of noise-absorbing plates with a brush or vacuum cleaner.
3. Synthetic fiber covering is for wet cleaning of noise-absorbing plates. Each noise-absorbing plate is placed into a galvanized steel frame and is used in cases when water treatment of silencers is required by hygienic standards. A large swing-out access door for removal of noise-absorbing plates is provided in the silencer casing with 2 and 3 type plates. After treatment the plates can be easily installed back. The special separators ensure the plates alignment.



**Filter section**



Applied for purification of supply and extract air to prevent the heat exchangers, fans, automation equipment against dusting. Coarse filters can be used as first stage purification filters before more efficient filters.

High degree of supply air purification is achieved due to utilization of built-in coarse and fine filters of panel and pocket types on a metal frame. Panel filter is a compact-sized coarse filter of G4 class as per EN 779 which is featured by shallow incorporation depth that provides efficient utilization of the unit internal space. Folded structure ensures relatively large filtering surface. The filter has insignificant aerodynamic resistance and long-term service life. The coarse filter enables extending of the main filter service life. Pocket filter has a special pocket-type design that provides extremely large filtering surface and extremely high dust capacity. The filter is featured by long service life and efficient operation. The filter consists of several filter cells varied from G3 to F9 class as per EN 779 (coarse and fine filters). The filters are fixed by means of locking rack bars with big handles to enable easy replacement of filtering elements. Filter clogging control as well as filter easy cleaning and removal ensure their high quality and durability in operation.

**Air shutoff dampers**



Designed for automatic shutoff of ventilating duct when ventilation system is out of operation. Airtightness of air handling unit shutoff dampers has class 3 as per EN 1751. The shutoff dampers consist of oppositely rotating blades with excellent aerodynamic characteristics. Rubber sealing between the blades and the casing prevents the air inflow. Provision is made for coldproof of the blades in case of operating at low temperatures. Gear drive made of durable heat-resisting plastic ensures smooth air stream regulation. The shutoff damper control is performed by means of electric spring-loaded drive to ensure the guaranteed blades closing during emergency power cutoff.

**Droplet separator**



Droplet separator is a device to prevent the dropping liquid carrying away with the air stream. The device consists of manifold bent plastic plates installed at the outlet of cooling and heat recovery units. Drop separation is effected due to multiple change of air stream direction in the plate bending. Water drops accumulate on blades and then flow into the drain pan.

Installed in air handling units at cooling or heat exchanging blocks outlet in case the air speed in the unit section 2.5 m/s and if drop separation and their penetration into the duct system is possible.

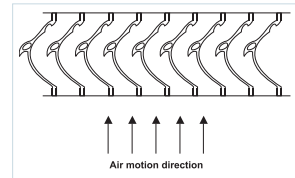

**Condensate drainage system**



The drain pan is designed for condensate collection and drainage. It is located angularly at the bottom of the heat exchanger and equipped with tapping.

**Inspection section  
Empty section**



The inspection section consists of the casing with the access door. Such section is installed between the components requiring inspection and maintenance and used in case some regular measurements are required in any other AHU component. The section can be equipped with the access cover and internal illumination that makes the inspection more comfortable.

An empty section is placed between the sections of the air handling unit and is used as place for sensors, i.e. temperature sensors. Later any other AHU section can be placed instead of the empty section.



The height of the mounting frame is adjusted by means of adjustable legs. The sections are interconnected with additional steel angles to increase the stability and rigidity. Easy-to-use door locks and handles for safe operation and quick maintenance.

Characteristic equipment list of ventilation units

Exhaust units

Exhaust fan

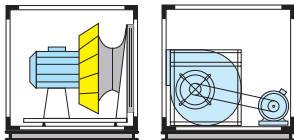

Exhaust fan with filter

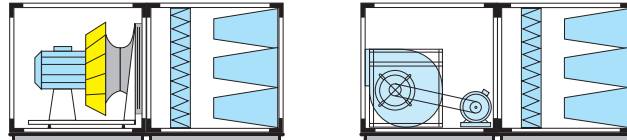

Supply units

Supply fan with filter and heater

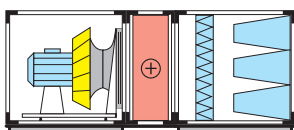

Supply fan with filter and cooler

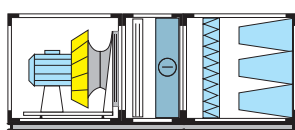

Supply fan with filter, heater and cooler

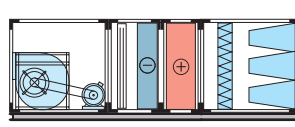
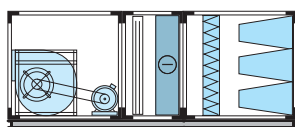
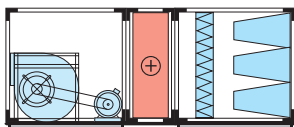
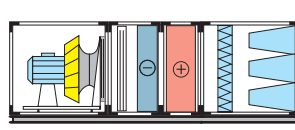

Air handling units with rotor heat exchanger

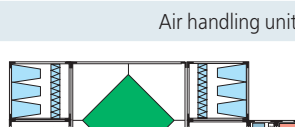
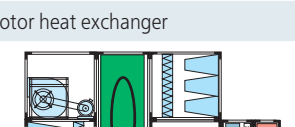

Air handling units with plate heat exchanger

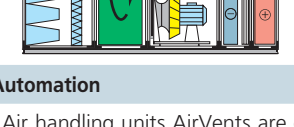

Automation

Air handling units AirVents are equipped with absolutely new automation set to ensure the professional and easy control of air ventilation and conditioning system. This automation provides comfortable low cost microclimate in any premises. Free programmable controller that operates jointly with remote control panel is the core of the new automation set. It ensures easy adjustment of parameters for ventilation and air conditioning system operation. Besides, the controller is open for external automation system.

Control unit for supply and exhaust units: Functions and applications:

- Control, monitoring, ensuring air handling unit operating parameters as operation, temperature, air capacity, emergency condition.
- Calendar-scheduled unit operation.
- Remote unit operation control from any place in the premise by means of external communicative elements.
- user interface;
- Joint operation with external units:
- external remote control panel;
- fire alarm system;
- CO2 detector
- zonal air curtains

Control unit functional diagrams:

VENTS control units ensure the control and reliable monitoring of all operating units and components composing the ventilation system of any configuration. See below some options for use of the control units depending on the equipment configuration.



AirVents air handling units integration into general centralized building management system (smart house).

Air handling units integration into general centralized building management system provides easy and comfortable control and monitoring of simultaneous operation of many ventilation units.

Freedom of choice is one of the main principles of the control system. The system is based on open standards. The controllers used in the control systems are fully controllable and support the most network protocols which are common in building automation as TCP/IP, LON.

The control system is therefore compatible with a wide range of equipment and software and can be integrated into centralized building management control. Control system has vast communication performance capabilities.

Controllers operate both in slow networks (e.g., dial-up) and fast networks (LAN/WAN). The system utilize different media for signal transmission as Internet, telephone connection, GSM, twisted pair. All these data transmission methods can be used either for connections between the controllers and for connection with SCADA system.

- Optional element for automation complex outfit.

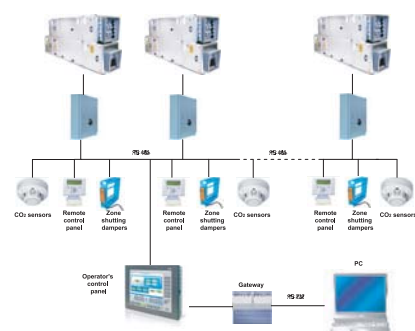

AirVents technical specification data sheet			
Company .....		/Building.....	
Contact person .....		Tell .....	
Tell.....		E-mail: <a href="http://www.vents.ua">www.vents.ua</a>	
E-mail.....		".....".....200....	
General			
<b>Unit:</b>	Exhaust <input type="checkbox"/>	Supply <input type="checkbox"/>	Supply & exhaust <input type="checkbox"/> Supply & exhaust with heat recovery <input type="checkbox"/>
<b>Mounting:</b>	Outdoor <input type="checkbox"/>	Indoor <input type="checkbox"/>	<b>Access side:</b> Left <input type="checkbox"/> Right <input type="checkbox"/>
<b>Supply &amp; exhaust parts:</b>	Lineary <input type="checkbox"/>	Side by side <input type="checkbox"/>	One on other <input type="checkbox"/>
Capacity and pressure		Supply	Exhaust
Capacity	.....	m <sup>3</sup> /hour	..... m <sup>3</sup> /hour
Pressure (system resistance)	.....	Pa	..... Pa
Air parameters		Winter	Summer
Supply	Outdoor air temperature and relative humidity	..... °C ..... %	..... °C ..... %
	Conditioned air temperature and relative humidity	..... °C ..... %	..... °C ..... %
Exhaust	Extract air temperature and relative humidity	..... °C ..... %	..... °C ..... %
	Exhaust air temperature and relative humidity	..... °C ..... %	..... °C ..... %
Sections required			
	<b>Fan</b>	Belt - driven <input type="checkbox"/>	Plug fan <input type="checkbox"/>
	<b>Filter</b>	Supply G4 <input type="checkbox"/> F7 <input type="checkbox"/> Other .....	Exhaust G4 <input type="checkbox"/> F7 <input type="checkbox"/> Other .....
	<b>Heater</b> <input type="checkbox"/>	Air temp before / after heater	..... °C/ ..... °C
	Electric <input type="checkbox"/>	Heater power	..... kWt
	Mixing set <input type="checkbox"/>	Water temp before / after heater	..... °C/ ..... °C
	<b>Cooling section</b> <input type="checkbox"/>	Air temp before / after heater	..... °C/ ..... °C
	Freon <input type="checkbox"/>	Heater power	..... kWt
	Mixing set <input type="checkbox"/>	Water temp before / after heater	..... °C/ ..... °C
	<b>Heat recovery section</b> <input type="checkbox"/>	Inlet temperature .....	..... °C Outlet temperature .... °C
	Plates <input type="checkbox"/>	Inlet humidity .....	..... % Outlet humidity ..... %
	Rotor <input type="checkbox"/>	Efficiency .....	
	<b>Silencer</b> <input type="checkbox"/>	Supply <input type="checkbox"/>	1200 mm long <input type="checkbox"/> ; other .....
		Exhaust <input type="checkbox"/>	
	<b>Air damper</b> <input type="checkbox"/>	Supply <input type="checkbox"/>	Exhaust <input type="checkbox"/>
	<b>Mixing section</b> <input type="checkbox"/>	Sirculating air	..... %
		Inlet air temperature .....	..... °C
		Inlet air humidity .....	..... °C
<b>Accessories:</b>	Flexible connection (inlet) <input type="checkbox"/>	Flexible connection (outlet) <input type="checkbox"/>	Mounting base frame <input type="checkbox"/>
<b>Controll system</b>	<input type="checkbox"/>		
<b>Additional information:</b>			

\* please indicate the control pattern in case of control board order

Fax the filled questionnaire +38 044 406 36 27

# AIR HEATING UNITS

## ▶ VENTS AOW Series



- ▶ Air heating unit with the water heat exchanger. The heating capacity 30 kW and the air capacity up to 3000 m<sup>3</sup>/h. Designed for cost-saving and efficient air heating in various premises.

## ▶ VENTS PVZ Series



- ▶ Air curtains are designed against cold or hot air streams into the door or window openings. They can be equipped with water heating coils or electrical heating batteries. Available standard sizes: 600x350, 700x400, 800x500, 900x500 mm.



**Air Heating unit  
VENTS AOW**

Air capacity – up to 3000 m<sup>3</sup>/h

page  
228



**Air curtain  
VENTS PVZ**

Air capacity – up to 84000 m<sup>3</sup>/h

page  
232



Series  
**AOW**



Air heating units with the water heat exchanger for cost-saving and effective air heating.

■ **Applications**

Designed for air heating by means of water heat medium which is uniformly distributed with the fan and guiding shutters. Air heating units provide quick heating of the large premises due to high-efficient air heater and powerful fan or local heating of any operating space, e.g. in large hangars or manufacturing workshops. Designed for heating of large-sized premises as manufacturing facilities, vehicle repair and car wash shops, garages and car sales centers, stocks, shopping malls, super- and hypermarkets, shops, sport halls, conference and exhibition halls, animal and poultry farms, greenhouses and other similar premises. Installation

of air-heating units reduces installation time and investment costs for heating system in general.

■ **Design**

AOW air heating unit consists of axial fan and aluminum-copper ribbed water heating coils in steel casing with polymeric covering. The water coils are equipped with internally threaded pipes for connection to the heat medium.

■ **Fan motor**

Asynchronous motors with external rotor and built-in thermal overheating protection with automatic restart.

■ **Control and regulation**

Both smooth or step speed control is performed by means of the thymistor or autotransformer controller. Motor speed decrease allows reducing air flow and quantity of removed heat. The heat medium flow can be regulated in various ways.

■ **Mounting**

The heat fan can be installed vertically on walls or columns or horizontally on ceiling or beams.

**Air heating advantages:**

- ▶ quick attaining of the set temperature in the premises,
- ▶ low system response time allows applying varying heating conditions or local heating,
- ▶ high heating capacity,
- ▶ investment for air heating system is much lower as compared with the similar heating system of water type.

**Designation key:** \_\_\_\_\_

Series	Rated power, kW
<b>VENTS AOW</b>	30



**Technical data:**

AOW 30	
Unit supply voltage [V / 50 Hz]	1~ 230
Fan power [W]	191
Fan current [A]	0,85
Air capacity [m³/h]	3000
Fan rotation speed [rpm]	1440
Warm air reach, m	20
Noise level at 3 m [dBA]	55
Maximum heat medium temperature [°C]	100
Protection rating	IP 44

**Overall dimensions:**

Type	Dimensions [mm]								Mass [kg]
	B	H	H2	H3	L	L2	K	Number of rows	
AOW 30	680	655	500	518	360	286	G1"	2	40,0

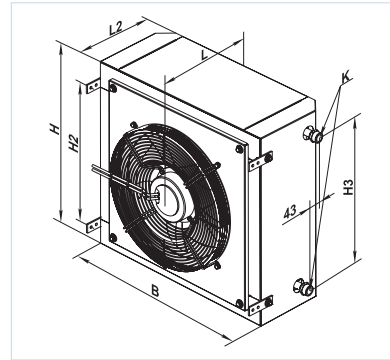

**Technical data:**

Air capacity [m³/h]	Water inlet temperature [°C]	Supply air temperature [°C]	AOW 30			
			Power [kW]	Outlet temperature [°C]	Water flow rate [l/s]	Water pressure loss [kPa]
3000	90/70	-15	48,4	27,2	0,58	13,3
		-10	45,4	30,4	0,56	11,8
		-5	42,4	33,4	0,53	10,4
		0	39,5	36,4	0,47	9,1
		5	36,6	39,3	0,44	7,9
		10	33,8	42,2	0,42	6,8
		15	30,9	44,9	0,39	5,8
	80/60	-15	42,5	22,1	0,53	10,6
		-10	39,6	25,3	0,47	9,3
		-5	36,6	28,2	0,44	8,1
		0	33,8	31,2	0,42	6,9
		5	30,9	34,0	0,39	5,9
		10	28,1	36,8	0,33	4,9
		15	25,2	39,5	0,31	4,1
	70/50	-15	36,6	16,9	0,44	8,2
		-10	33,7	19,9	0,42	7,1
		-5	30,8	22,9	0,39	6,0
		0	27,9	25,7	0,33	5,0
		5	25,1	28,5	0,31	4,1
		10	22,2	31,2	0,28	3,3
		15	19,4	33,8	0,25	2,6
	60/40	-15	30,5	11,7	0,36	6,0
		-10	27,6	14,6	0,33	5,0
		-5	24,7	17,4	0,31	4,1
0		21,8	20,1	0,28	3,3	
5		18,9	22,8	0,22	3,0	
10		16,0	25,3	0,19	1,9	
15		13,0	27,6	0,17	1,3	

HEATING UNITS  
AOW



AOW heating unit gym heating example.



AOW heating unit greenhouse heating example.

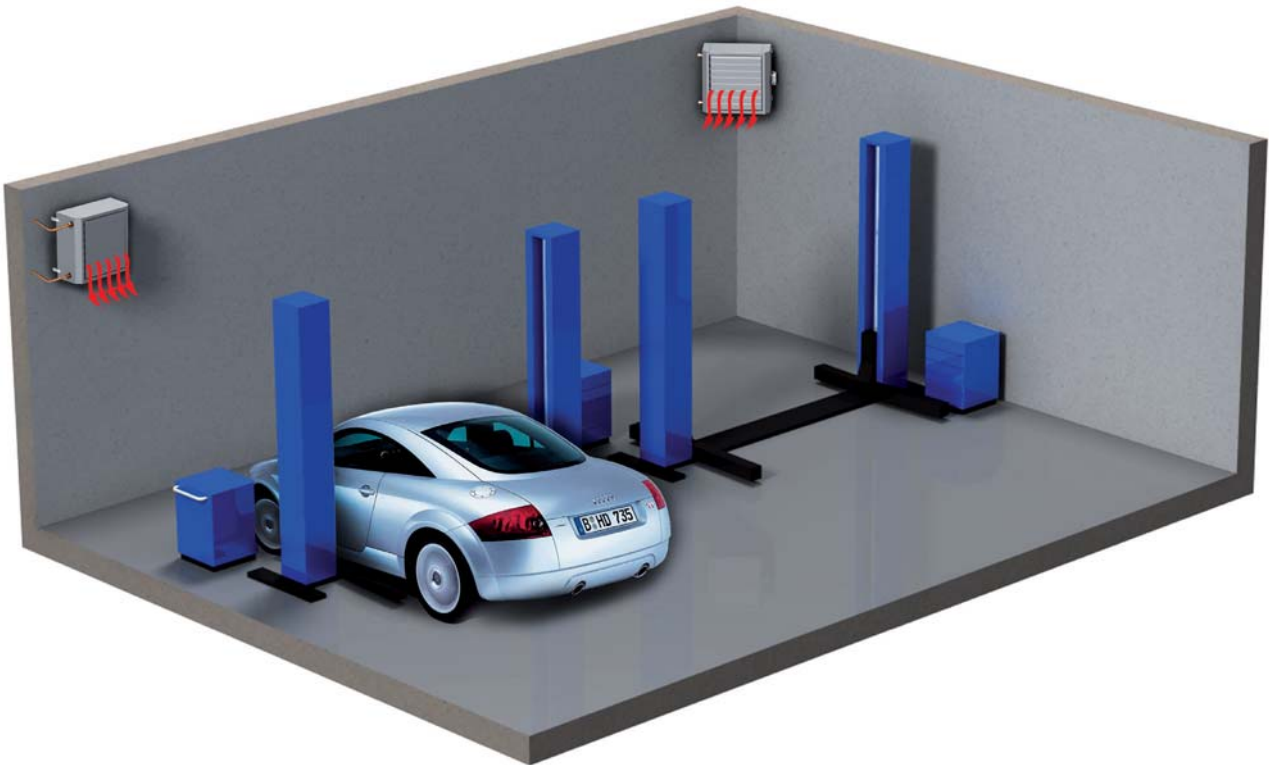

AOW heating unit vehicle repair shop heating example.

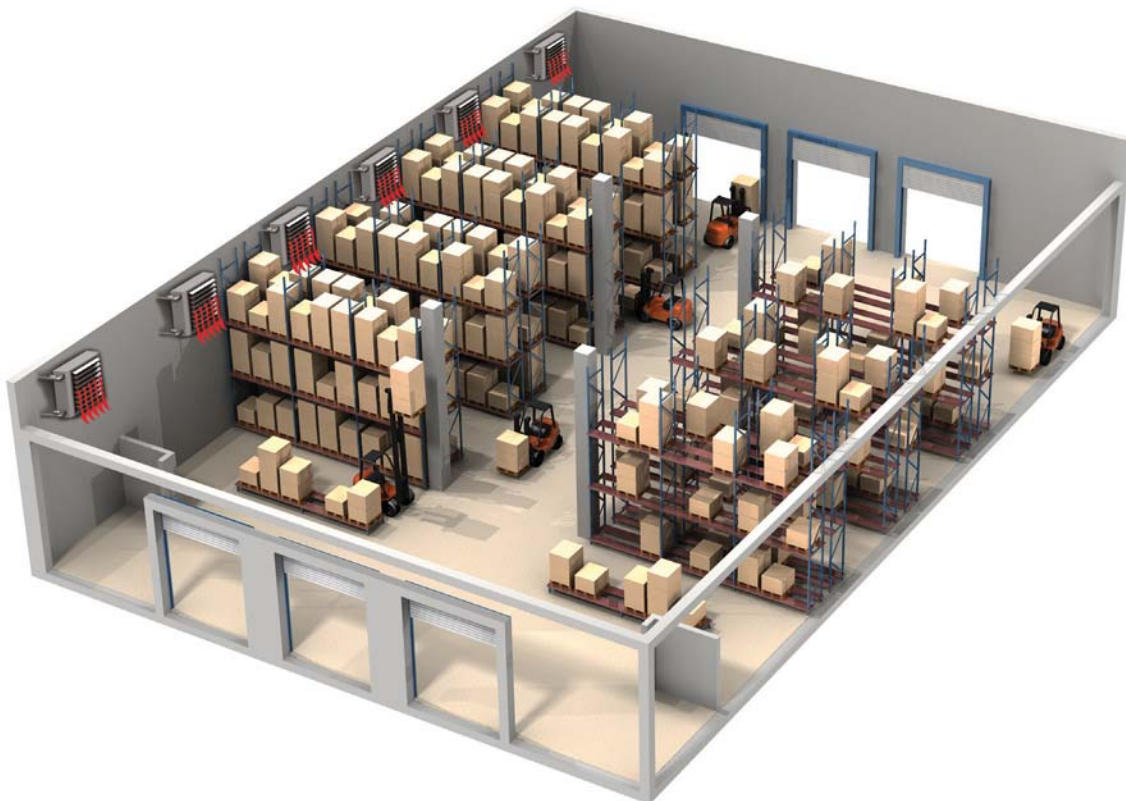

AOW heating unit stock heating example.

Series  
**PVZ**



The air curtains application contributes much to significant cost saving for the house cooling or heating due to invisible aerodynamic barrier between indoor and outdoor spaces, for instance, at the building entry.

■ **Applications**

The air curtains are designed to prevent the cold or hot air streams from outside into door openings or gateways.

The height or width of the covered areas ranges from 2 to 5 meters. The air curtains are suitable for crowded premises with increased traffic load. Designed for application in manufacturing premises, stocks, garages, car service centers and car wash shops, shopping malls, super- and hypermarkets, conference and exhibition halls, and other premises.

■ **Operating logic of the air curtain**

Rectangular duct high pressure fan is applied in air curtain. The supply air is filtered and then supplied to the premise through a narrow slit which ensures the outlet air speed increase and its correct operation. If the curtain has a water or electrical heater the supplied air is warmed up to the set temperature. The aerodynamic barrier created in such a way separates the premise from environment.

■ **Design**

Air curtains are available in 4 standard sizes depending on the capacity. The curtains and their components are made of galvanized steel. Rectangular duct high pressure fan serves for air supply. G4 panel filter provides air filtration. Air heating is effected by means of water heating coils or electrical heater.

If water serve as a heat medium these curtain types are suitable for the premises with the indoor temperature not below 0°C only. Air distribution is performed through the slit sections. The standard slit sections are 1 to 1.5m long that enables easy selection for any door opening.

■ **Fan motor**

The impellers with forward-curved blades made of galvanized steel are powered by four- or six-pole asynchronous motors with external rotor. The fans with such turbine modification are featured with relatively high pressure differential and high air flow capacity. For thermal overheating protection the thermal contacts with the leaded terminals are built in the motor winding for connection to the external protection devices.

■ **Mounting**

Both horizontal and vertical mounting is possible. In case of horizontal mounting the air curtain is fixed above the door opening and creates the air stream vertically downwards along the whole opening width. In case of vertical mounting the curtain is fixed at one side or at both sides of the opening and the air is streamed horizontally. One vertical curtain covers 10 to 12 m<sup>2</sup> space and for larger surfaces the air curtains at both sides shall be installed to increase the effective area.

Designation key:

Series	Standard size	Heater type	Slit outlet section length
<b>PVZ</b>	600x350 700x400 800x500 900x500	<b>W</b> – water coils <b>E</b> – electrical heating elements <b>N</b> – no heater	2; 2,5; 3; 3,5; 4; 4,5; 5



**Technical data:**

	PVZ 600x350	PVZ 700x400	PVZ 800x500	PVZ 900x500
Voltage [V]	3~ 400	3~ 400	3~ 400	3~ 400
Air capacity [m³/h]	4000	6000	6200	8400
Fan power [kW]	2,46	3,63	2,79	3,87
Fan current [A]	3,93	6,0	5,18	7,0
Electric heater power [kW]	21	36	36	45
Electric heater current [A]	30	52	52	65
Fan type	VKPF 4D 600x350	VKPF 4D 700x400	VKPF 6D 800x500	VKPF 6D 900x500
Filter type	FB 600x350	FB 700x400	FB 800x500	FB 900x500
Water heating coils type	NKW 600x350-2	NKW 700x400-2	NKW 800x500-2	NKW 900x500-2
Electric heating battery type	NK 600x350-21,0-3	NK 700x400-36,0-3	NK 800x500-36,0-3	NK 900x500-45,0-3

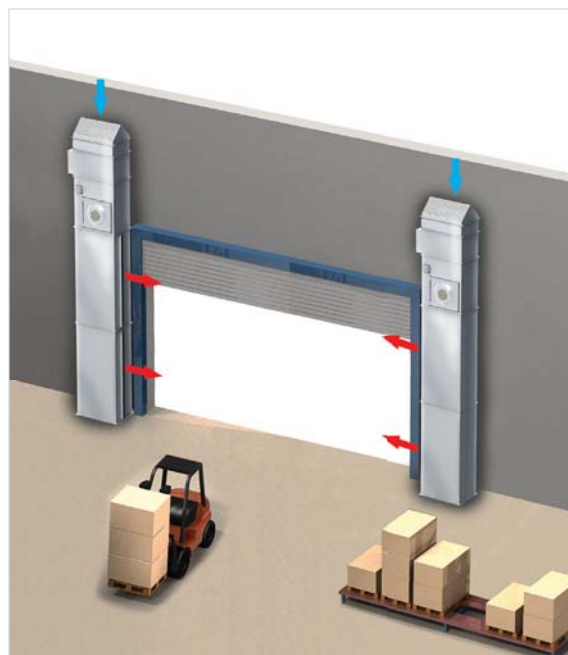
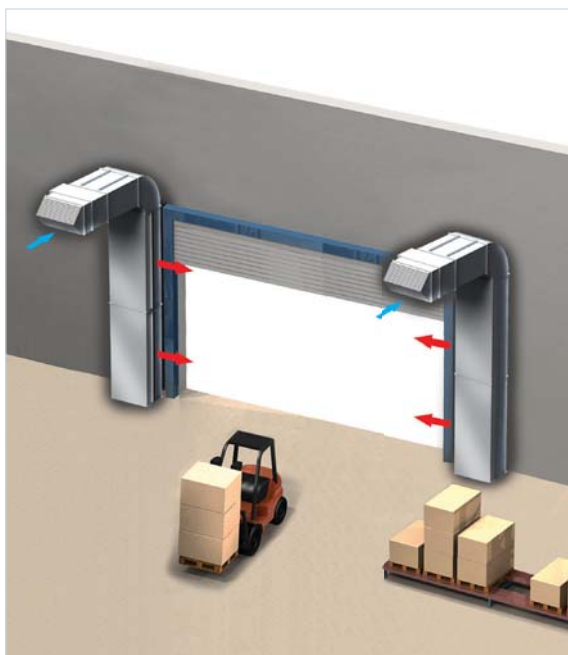
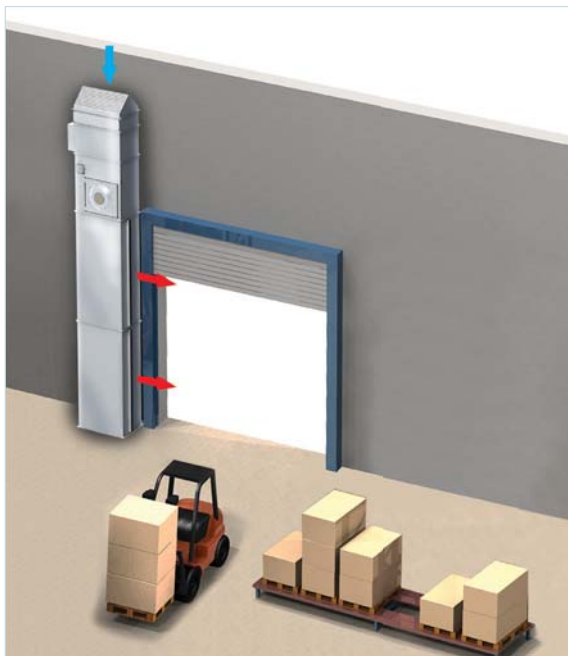

PVZ

AIR CURTAINS



## AIR CURTAINS

### Overall dimensions:

	PVZ 600x350	PVZ 700x400	PVZ 800x500	PVZ 900x500
W, mm	600	700	800	900
L, mm	350	400	500	500
H1, mm	from 2.0 up to 5.0			
H2 (curtain with no heating), mm	1150	1300	1450	1520
H2 (curtain with water heating coils), mm	1350	1500	1650	1720
H2 (curtain with electric heating battery), mm	1350	2050	1960	2270

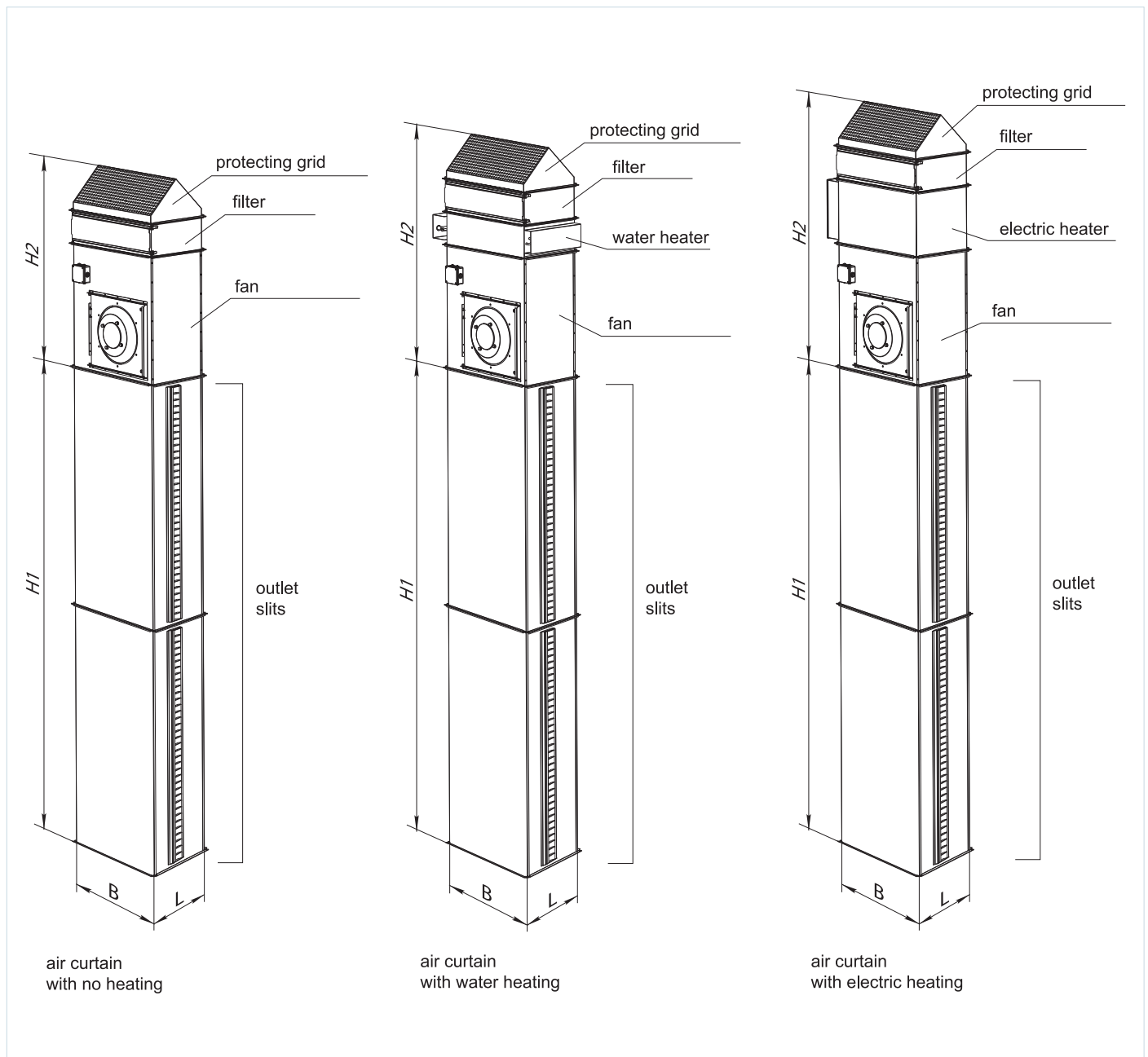

### Nomographic charts for air curtain selection

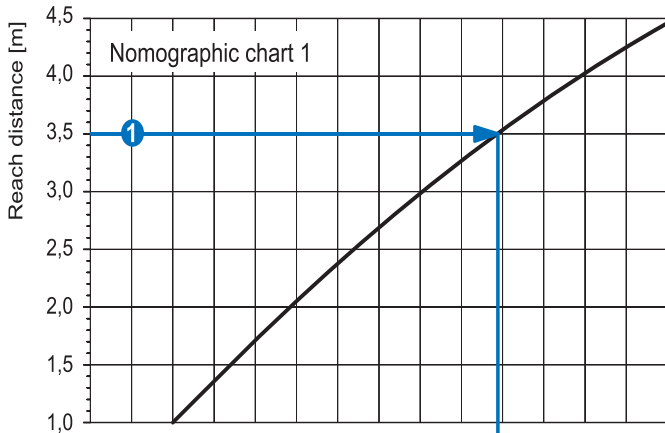

#### Air curtain selection procedure

- Determine the required air curtain orientation (e.g., vertical).
- Determine the required heating type (W - water type, E - electrical type, N - no heating).
- The nomographic chart 1 shows the effective reach distance of the curtain **1** (e.g., 3.5 m; for vertical orientation that value is equal to the door opening width).
- For the outlet air stream speed from the curtain draw a perpendicular line down to the nomographic chart **2** (e.g., 13.9 m/s).
- Using the nomographic chart 3 determine the outlet slit of the air curtain **3** (e.g., 2.5 m; for vertical orientation that is equal to the height of the door opening).
- The nomographic chart 4 shows the minimum required air capacity (lines **4** and **5**, e.g., 4400 m<sup>3</sup>/h).
- The intersection of curves **5** and **6** lies on one of the colour fields of the design chart 5. The field of the point location determines the standard size of the air curtain (e.g., 800x500).
- Projection of curve along the parabola **7** up to the point of intersection with the curve that limits the colour field from above, determines the operating point of the air curtain. The air capacity 4800 m<sup>3</sup>/h which is somewhat above the minimum required air capacity refers to the effective operating point.

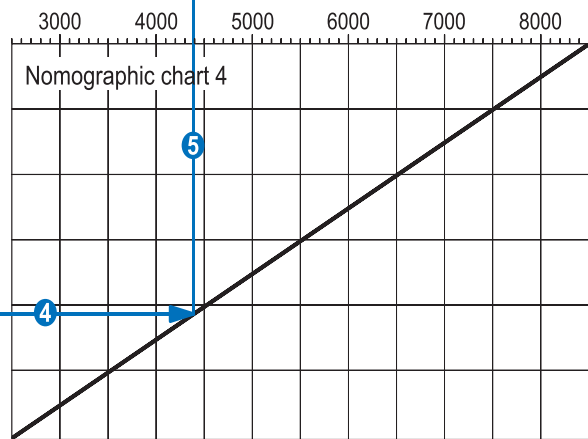
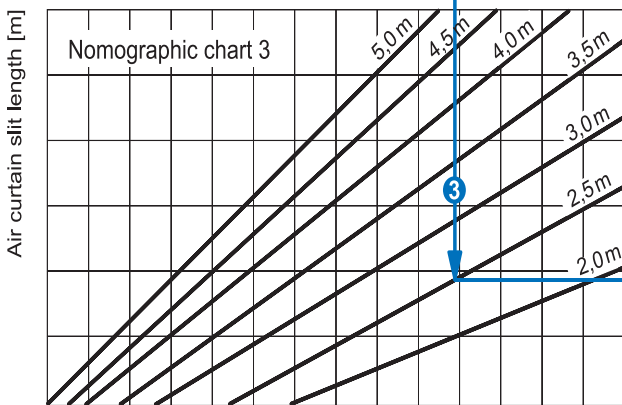
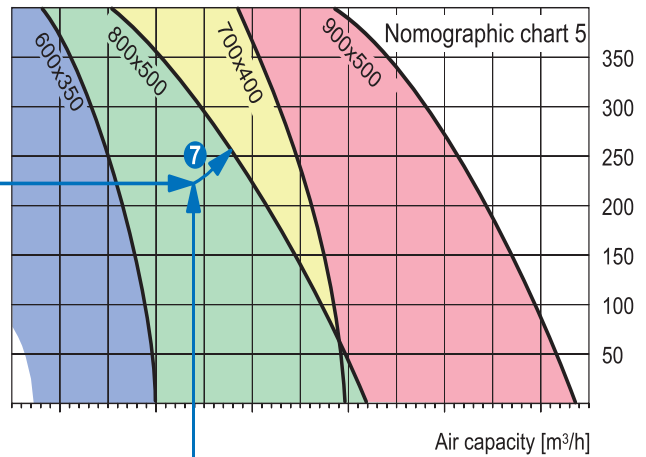
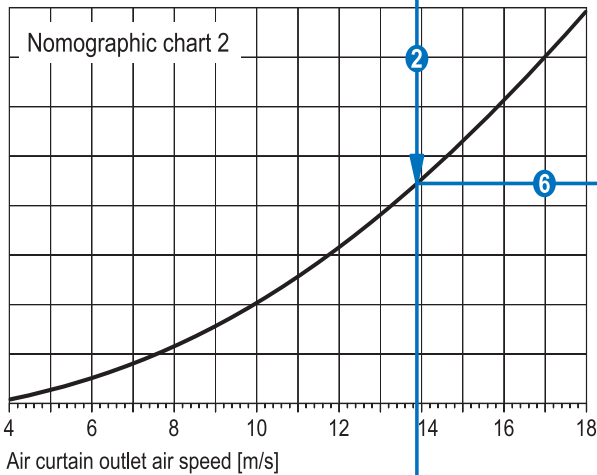



# ACCESSORIES

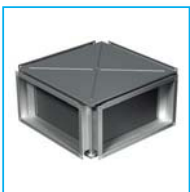

Plate heat exchangers

page  
238



Silencers

page  
240



Plate filters

page  
248



Pocket filters

page  
250



Heaters

page  
254



Mixing set

page  
280



**Coolers**

**page  
282**



**Dampers**

**page  
294**



**Shutoff dampers**

**page  
296**



**Air flow controllers**

**page  
298**



**Backdraft dampers**

**page  
300**



**Flexible connectors**

**page  
301**



**Mixing chambers**

**page  
302**



**Clamps**

**page  
304**

Series  
**PR**

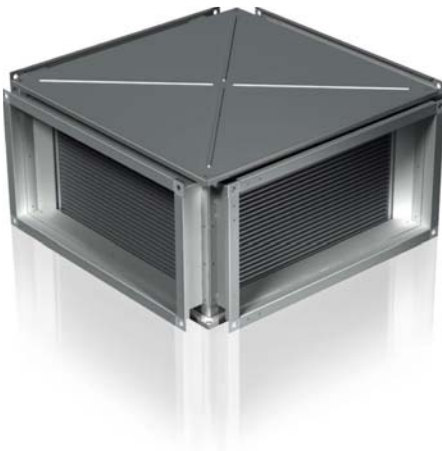

■ **Applications**

PR plate heat exchanger with X-shaped air passage designed for exhaust air heat recovery in conditioning and ventilating systems. The heat exchangers are connected directly to the rectangular ducts both with parallel and perpendicular or diagonal ducting at 45°. Various connection modifications are possible due to bend fittings which shall be ordered in the required quantity. The transported air shall not contain solid, fibrous, aggressive and explosive impurities.

■ **Design**

The heat exchanger casing is made of galvanized steel. The surface of the heat exchanger consists of thin aluminium plates for efficient heat exchange. Some condensate quantity which can be generated

at exhaust surface can be removed at the bottom removable panel. PR heat exchangers equipment list includes connecting pipe on the bottom panel for condensate removing.

■ **Technical data**

Efficiency or performance is the basic characteristics of the plate heat exchangers along with the air resistance in the duct. The thermal efficiency is calculated as following:

$$\eta = \frac{t_p - t_i}{t_e - t_i}$$

$t_p$  – supply air temperature after heat recuperation;  
 $t_i$  – intake air temperature before heat recuperation;  
 $t_e$  – extract air temperature before heat recuperation.

**Accessory**

PK bend  
 Designed for easy mounting of the heat exchanger in any modifications of the air duct.

Bend designation  
 PK 600 x 300



**Accessory**

Summer block VL  
 For the summer period the heat exchanger can be replaced with the summer block VL which performs no heat recovery but reduces pressure loss by 10%. It is applied in systems without by-pass at the inlet and in systems with no cooling.

Possible layout arrangements of PR heat exchanger and bends PK:

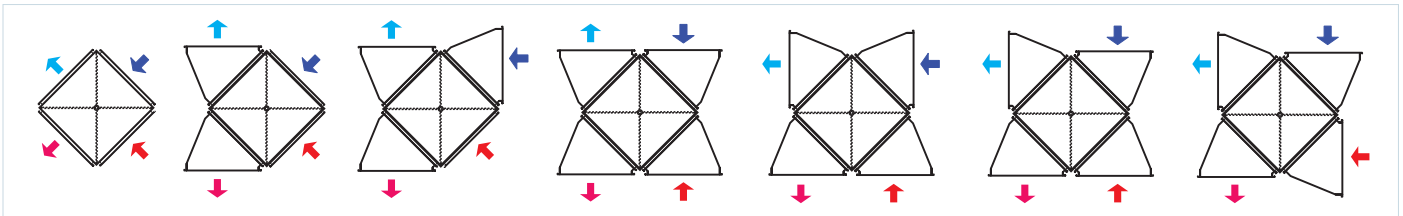

Designation key:

Series	Flange designation (WxH) [mm]
PR PK	400x200; 500x250; 500x300; 600x300; 600x350; 700x400; 800x500; 900x500; 1000x500
VL	400x200; 500x250; 500x300; 600x300; 600x350; 700x400; 800x500; 900x500; 1000x500



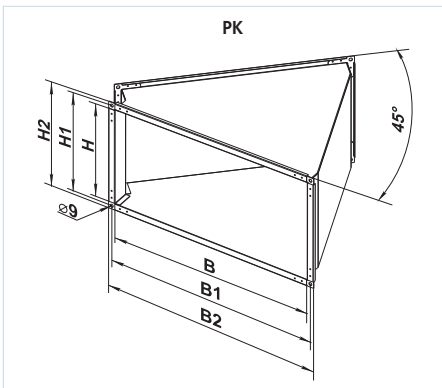

**Overall dimensions:**

Type	Dimensions [mm]						Mass, [kg]
	B	B1	B2	H	H1	H2	
PK 400x200	400	420	440	200	220	240	2,2
PK 500x250	500	520	540	250	270	290	3,3
PK 500x300	500	520	540	300	320	340	3,5
PK 600x300	600	620	640	300	320	340	4,5
PK 600x350	600	620	640	350	370	390	4,7
PK 700x400	700	720	740	400	420	440	5,9
PK 800x500	800	820	840	500	520	540	7,5
PK 900x500	900	920	940	500	520	540	8,7
PK 1000x500	1000	1020	1040	500	520	540	10,3

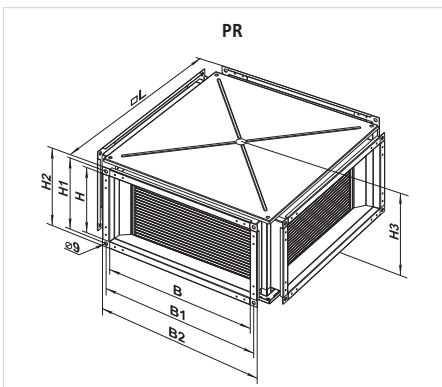

**Overall dimensions:**

Type	Dimensions [mm]								Mass, [kg]
	B	B1	B2	H	H1	H2	H3	L	
PR 400x200	400	420	440	200	220	240	275	530	17,1
PR 500x250	500	520	540	250	270	290	325	630	22,6
PR 500x300	500	520	540	300	320	340	375	630	24,2
PR 600x300	600	620	640	300	320	340	375	730	31,0
PR 600x350	600	620	640	350	370	390	425	730	33,4
PR 700x400	700	720	740	400	420	440	475	830	47,8
PR 800x500	800	820	840	500	520	540	575	930	61,1
PR 900x500	900	920	940	500	520	540	575	1130	78,8
PR 1000x500	1000	1020	1040	500	520	540	575	1130	78,3

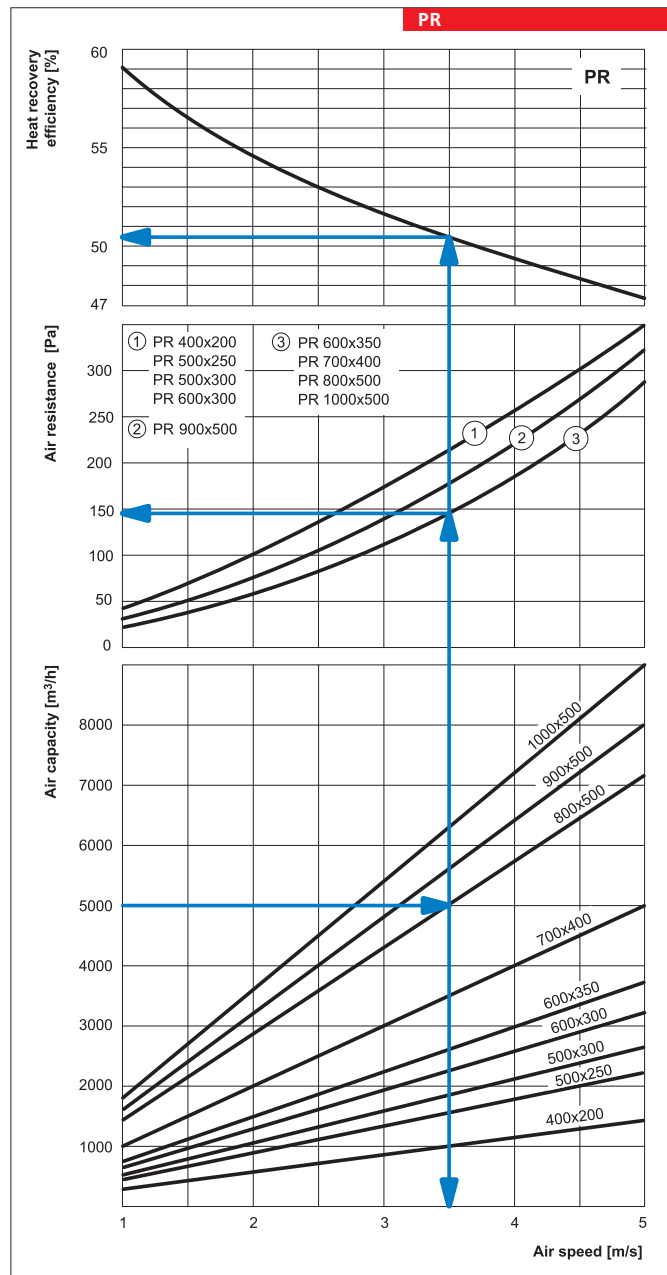

Series  
**SR**



Series  
**SRF**



■ **Applications**

Silencer is applied for noise absorption produced during the ventilating equipment operation and spread along the ducting systems. Suitable for installation into round ducts. The silencer reduces the noise level in the air duct significantly (refer the diagram «Noise level reduction»). The silencer is applied jointly with the sound-insulated fan in case of low-noise requirements not only to the air duct but to the equipment altogether.

■ **Design**

- The galvanized steel casing is filled with flameproof sound insulating material and equipped with protecting covering against fiber blowing-out and connecting flanges with rubber sealing for airtight connection to the air ducts.

- SRF silencer casing consists of internal and external aluminium-alloy spiral seam tubes filled with flameproof sound insulating material. The casing external surface is perforated and has the protecting cover to prevent the fiber blowing-out. The minimum bending radius of the silencer is up to 2 diameters. Each standards size has several length modifications.

■ **Mounting**

The silencer design allows fixing it on the round ducts in any position by means of clamps. The linear mounting is preferable for to attain the better effect. To prevent the flexible silencer sagging it should be fixed not only at the ends but in the middle.

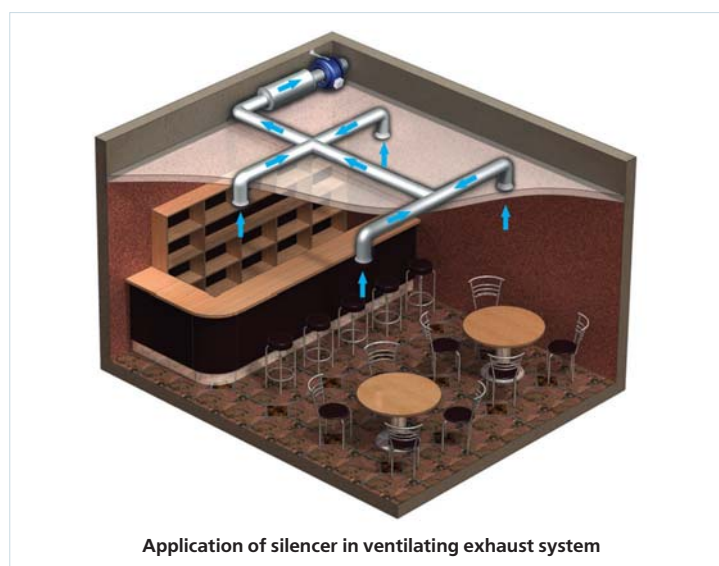

Designation key: \_\_\_\_\_

Series	Air duct diameter, mm	Length
<b>SR</b> <b>SRF</b>	100; 125; 150; 160; 200; 250; 315	600; 900; 1200; 2000

	Noise level reduction, dB (Octave-frequency band [Hz])							
	63 Hz	125 Hz	250 Hz	500 Hz	1000 Hz	2000 Hz	4000 Hz	8000 Hz
SR 100/600	4	8	10	20	34	30	13	14
SR 100/900	5	10	15	23	44	30	16	15
SR 100/1200	6	11	19	28	50	34	20	18
SR 125/600	3	5	6	15	28	17	10	9
SR 125/900	4	9	12	22	43	22	16	12
SR 125/1200	4	9	16	27	48	27	21	17
SR 150/600	2	4	8	16	32	11	7	7
SR 150/900	3	5	9	18	36	25	13	14
SR 150/1200	4	8	14	25	43	30	18	19
SR 160/600	2	4	8	17	33	11	7	7
SR 160/900	2	5	10	19	37	25	13	15
SR 160/1200	4	10	14	24	42	30	19	20
SR 200/600	2	4	6	10	27	13	7	7
SR 200/900	3	7	11	20	39	23	8	7
SR 200/1200	4	10	14	23	40	26	13	12
SR 250/600	4	5	6	11	22	12	7	6
SR 250/900	4	5	7	16	32	20	12	10
SR 250/1200	4	6	8	17	34	22	14	12
SR 315/600	2	4	5	10	17	9	6	5
SR 315/900	3	5	8	17	30	14	10	8
SR 315/1200	4	7	11	22	36	18	14	10

	Noise level reduction, dB (Octave-frequency band [Hz])							
	63 Hz	125 Hz	250 Hz	500 Hz	1000 Hz	2000 Hz	4000 Hz	8000 Hz
SRF 100/600	6	8	13	22	28	34	17	20
SRF 100/900	8	10	15	25	33	40	21	23
SRF 100/2000	10	15	24	48	53	51	39	36
SRF 125/600	4	7	14	20	31	31	13	12
SRF 125/900	5	9	16	23	36	37	17	16
SRF 125/2000	7	15	23	47	55	50	28	25
SRF 150/600	3	7	12	32	40	40	19	20
SRF 150/900	4	8	14	40	48	49	26	25
SRF 150/2000	5	10	21	42	50	48	26	25
SRF 160/600	3	7	12	20	25	24	10	12
SRF 160/900	3	8	13	21	28	28	13	16
SRF 160/2000	5	11	20	40	48	48	25	25
SRF 200/600	2	5	12	20	26	21	10	10
SRF 200/900	3	6	12	22	28	24	12	13
SRF 200/2000	4	11	22	42	51	34	19	23
SRF 250/600	2	3	8	16	22	13	10	10
SRF 250/900	2	4	9	18	25	16	11	12
SRF 250/2000	3	6	16	30	39	27	17	22
SRF 315/600	2	4	9	18	21	12	7	9
SRF 315/900	2	5	11	21	24	14	8	10
SRF 315/2000	4	7	17	34	39	24	14	18

## SILENCERS

### Overall dimensions:

Type	Dimensions [mm]				Mass, [kg]
	∅D	∅D1	L	L1	
SR 100/600	99	200	600	50	2,2
SR 100/900	99	200	900	50	3,2
SR 100/1200	99	200	1200	50	4,3
SR 125/600	124	225	600	50	2,7
SR 125/900	124	225	900	50	4,1
SR 125/1200	124	225	1200	50	5,4
SR 150/600	149	250	600	50	2,8
SR 150/900	149	250	900	50	4,2
SR 150/1200	149	250	1200	50	5,6
SR 160/600	159	260	600	50	3,1
SR 160/900	159	260	900	50	4,6
SR 160/1200	159	260	1200	50	6,2
SR 200/600	199	300	600	50	3,5
SR 200/900	199	300	900	50	5,3
SR 200/1200	199	300	1200	50	7,1
SR 250/600	249	350	600	50	4,2
SR 250/900	249	350	900	50	6,2
SR 250/1200	249	350	1200	50	8,3
SR 315/600	314	415	600	50	4,7
SR 315/900	314	415	900	50	7,1
SR 315/1200	314	415	1200	50	9,4

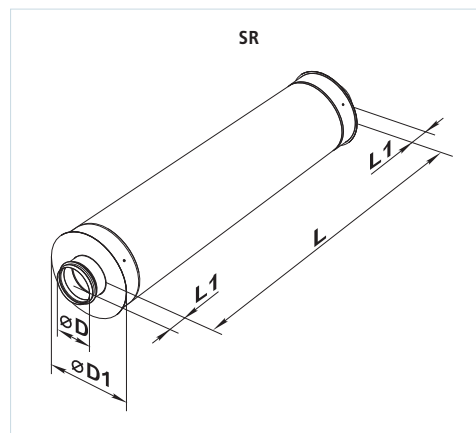

### Overall dimensions:

Type	Dimensions [mm]				Mass, [kg]
	∅D	∅D1	L	L1	
SRF 100/600	99	200	600	50	1,5
SRF 100/900	99	200	900	50	2,2
SRF 100/2000	99	200	2000	50	4,8
SRF 125/600	124	225	600	50	1,8
SRF 125/900	124	225	900	50	2,7
SRF 125/2000	124	225	2000	50	6,0
SRF 150/600	149	250	600	50	1,9
SRF 150/900	149	250	900	50	2,8
SRF 150/2000	149	250	2000	50	6,2
SRF 160/600	159	260	600	50	2,1
SRF 160/900	159	260	900	50	3,1
SRF 160/2000	159	260	2000	50	6,8
SRF 200/600	199	300	600	50	2,4
SRF 200/900	199	300	900	50	3,5
SRF 200/2000	199	300	2000	50	7,8
SRF 250/600	249	350	600	50	2,8
SRF 250/900	249	350	900	50	4,2
SRF 250/2000	249	350	2000	50	9,2
SRF 315/600	314	415	600	50	3,2
SRF 315/900	314	415	900	50	4,7
SRF 315/2000	314	415	2000	50	10,4

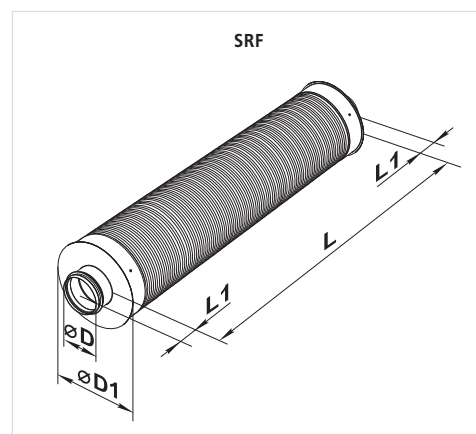

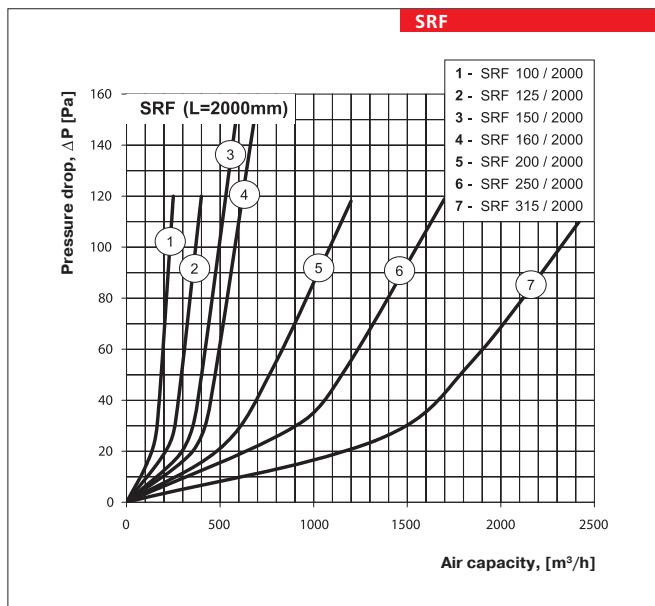
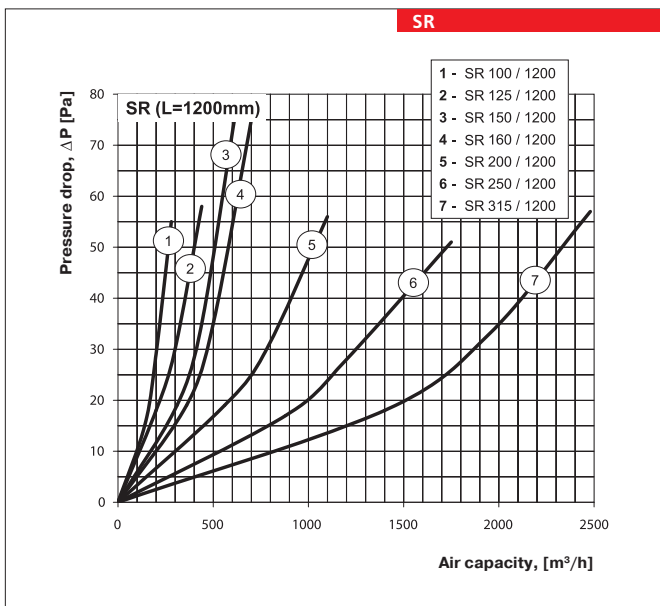
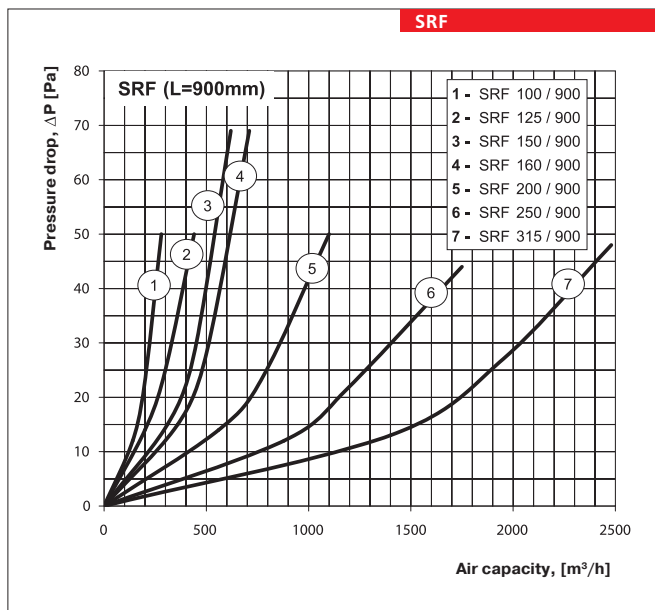
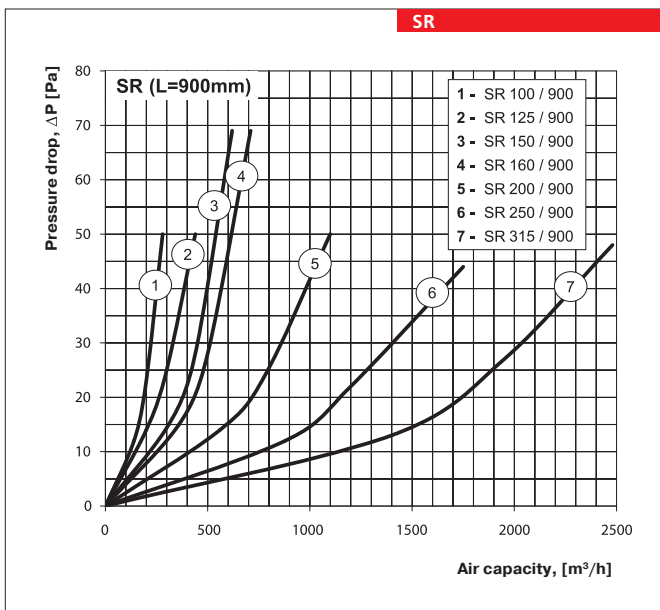
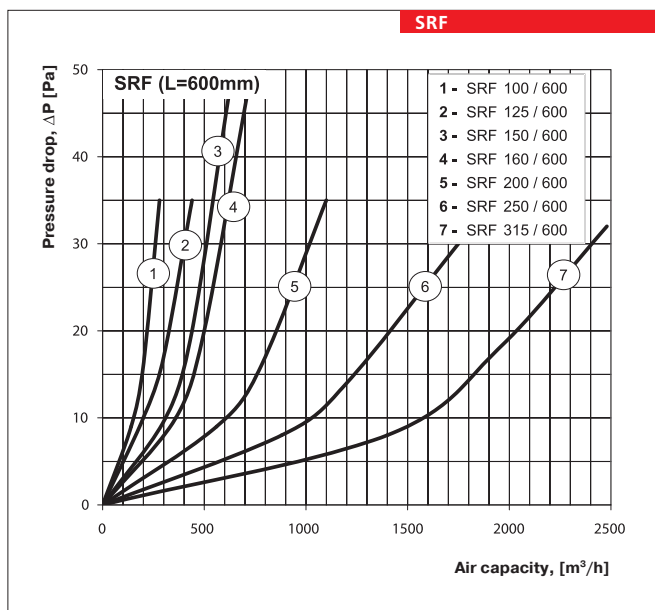
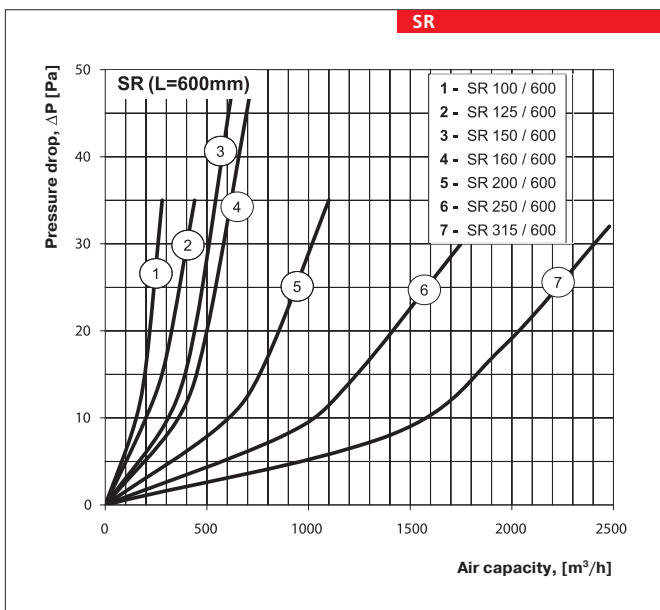

SR  
SRF  
SILENCER



Series  
**SRP**



Series  
**SRN**



■ **Applications**

Silencer is applied for noise absorption produced during the ventilating equipment operation and spread along the ducting systems. Suitable for installation into round ducts. The silencer reduces the noise level in the air duct significantly (refer the diagram «Noise level reduction»). The silencer is applied jointly with the sound-insulated fan in case of high level requirements not only to the air duct but to the equipment altogether.

■ **Design**

- **SRP** silencer consists of external and internal flexible air duct made of aluminum foil and laminated with polyether film. The ducts are reinforced by the scroll

frame made of high-carbon steel wire. The internal air duct is made of micro-perforated aluminium foil. 25 mm mineral wool layer is laid between the air ducts. The silencer is equipped with the connecting flanges with rubber sealing that provides the airtight connection to the air ducts. Each standards size has several length modifications.

- **SRN** silencer consists of the internal and external flexible air duct made of metallized polyether film. The ducts are reinforced by the scroll frame made of high-carbon steel wire. 25 mm mineral woollayer is laid between the air ducts. The silencer is equipped with connecting flanges with rubber sealing which provides the airtight connection to the air ducts. Each standards

size has several length modifications.

■ **Mounting**

The silencer design allows fixing it on the round ducts in any position by means of clamps. Installation in series is preferable to attain the better effect. To prevent the flexible silencer sagging it should be fixed not only at the ends but in the middle as well.

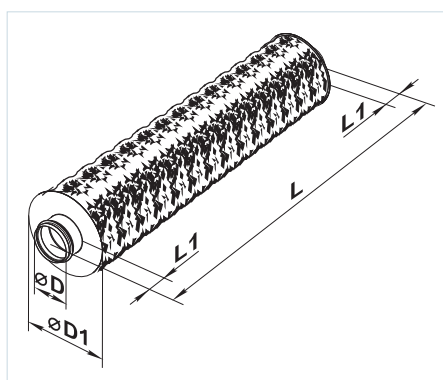

**Designation key:**

Series	Air duct diameter, mm	Length
SRP SRN	100; 125; 150; 160; 200; 250; 315	500; 600; 750; 900; 1200; 1500; 2000

**Overall dimensions:**

Type	Dimensions [mm]				Mass [kg]
	∅D	∅D1	L	L1	
SRP 100/500	99	162	600	50	0,56
SRP 100/600	99	162	700	50	0,62
SRP 100/750	99	162	850	50	0,72
SRP 100/900	99	162	1000	50	0,82
SRP 100/1200	99	162	1300	50	1,02
SRP 100/1500	99	162	1600	50	1,22
SRP 100/2000	99	162	2100	50	1,55
SRP 125/500	124	187	600	50	0,66
SRP 125/600	124	187	700	50	0,74
SRP 125/750	124	187	850	50	0,86
SRP 125/900	124	187	1000	50	0,97
SRP 125/1200	124	187	1300	50	1,21
SRP 125/1500	124	187	1600	50	1,44
SRP 125/2000	124	187	2100	50	1,83
SRP 150/500	149	212	600	50	0,91
SRP 150/600	149	212	700	50	1,00
SRP 150/750	149	212	850	50	1,14
SRP 150/900	149	212	1000	50	1,27
SRP 150/1200	149	212	1300	50	1,54
SRP 150/1500	149	212	1600	50	1,81
SRP 150/2000	149	212	2100	50	2,27
SRP 160/500	159	212	600	50	0,94
SRP 160/600	159	212	700	50	1,03
SRP 160/750	159	212	850	50	1,16
SRP 160/900	159	212	1000	50	1,30
SRP 160/1200	159	212	1300	50	1,57
SRP 160/1500	159	212	1600	50	1,84
SRP 160/2000	159	212	2100	50	2,29
SRP 200/500	199	264	600	50	1,25
SRP 200/600	199	264	700	50	1,36
SRP 200/750	199	264	850	50	1,53
SRP 200/900	199	264	1000	50	1,71
SRP 200/1200	199	264	1300	50	2,05
SRP 200/1500	199	264	1600	50	2,40
SRP 200/2000	199	264	2100	50	2,98
SRP 250/500	249	314	600	50	1,53
SRP 250/600	249	314	700	50	1,67
SRP 250/750	249	314	850	50	1,88
SRP 250/900	249	314	1000	50	2,09
SRP 250/1200	249	314	1300	50	2,51
SRP 250/1500	249	314	1600	50	2,93
SRP 250/2000	249	314	2100	50	3,63
SRP 315/500	314	365	600	50	1,87
SRP 315/600	314	365	700	50	2,04
SRP 315/750	314	365	850	50	2,30
SRP 315/900	314	365	1000	50	2,55
SRP 315/1200	314	365	1300	50	3,06
SRP 315/1500	314	365	1600	50	3,56
SRP 315/2000	314	365	2100	50	4,41

**Overall dimensions:**

Type	Dimensions [mm]				Mass, [kg]
	∅D	∅D1	L	L1	
SRN 100/500	99	162	600	50	0,56
SRN 100/600	99	162	700	50	0,62
SRN 100/750	99	162	850	50	0,72
SRN 100/900	99	162	1000	50	0,82
SRN 100/1200	99	162	1300	50	1,02
SRN 100/1500	99	162	1600	50	1,22
SRN 100/2000	99	162	2100	50	1,55
SRN 125/500	124	187	600	50	0,66
SRN 125/600	124	187	700	50	0,74
SRN 125/750	124	187	850	50	0,86
SRN 125/900	124	187	1000	50	0,97
SRN 125/1200	124	187	1300	50	1,21
SRN 125/1500	124	187	1600	50	1,44
SRN 125/2000	124	187	2100	50	1,83
SRN 150/500	149	212	600	50	0,91
SRN 150/600	149	212	700	50	1,00
SRN 150/750	149	212	850	50	1,14
SRN 150/900	149	212	1000	50	1,27
SRN 150/1200	149	212	1300	50	1,54
SRN 150/1500	149	212	1600	50	1,81
SRN 150/2000	149	212	2100	50	2,27
SRN 160/500	159	212	600	50	0,94
SRN 160/600	159	212	700	50	1,03
SRN 160/750	159	212	850	50	1,16
SRN 160/900	159	212	1000	50	1,30
SRN 160/1200	159	212	1300	50	1,57
SRN 160/1500	159	212	1600	50	1,84
SRN 160/2000	159	212	2100	50	2,29
SRN 200/500	199	264	600	50	1,25
SRN 200/600	199	264	700	50	1,36
SRN 200/750	199	264	850	50	1,53
SRN 200/900	199	264	1000	50	1,71
SRN 200/1200	199	264	1300	50	2,05
SRN 200/1500	199	264	1600	50	2,40
SRN 200/2000	199	264	2100	50	2,98
SRN 250/500	249	314	600	50	1,53
SRN 250/600	249	314	700	50	1,67
SRN 250/750	249	314	850	50	1,88
SRN 250/900	249	314	1000	50	2,09
SRN 250/1200	249	314	1300	50	2,51
SRN 250/1500	249	314	1600	50	2,93
SRN 250/2000	249	314	2100	50	3,63
SRN 315/500	314	365	600	50	1,87
SRN 315/600	314	365	700	50	2,04
SRN 315/750	314	365	850	50	2,30
SRN 315/900	314	365	1000	50	2,55
SRN 315/1200	314	365	1300	50	3,06
SRN 315/1500	314	365	1600	50	3,56
SRN 315/2000	314	365	2100	50	4,41

Series  
**SR**



■ **Applications**

The plate silencer is applied for noise absorption produced during the ventilating equipment operation and spread along the ducting systems. Suitable for installation into rectangular ducts. The silencer reduces the noise level in the air duct significantly (refer the diagram «Noise level reduction»). The silencer is applied jointly with the sound-insulated fan

in case of high noise level requirements not only to the air duct but to the equipment in general.

■ **Design**

Silencer casing and plate shells are made of galvanized steel. The plates are filled with flameproof sound insulating material with protecting covering to prevent the fiber blowing-out.

■ **Mounting**

The mounting is performed by means of flange connection with respect to air flow direction (indicated with an arrow on the casing). The straight portion of at least 1 m long before the silencer is recommended to provide the peak efficiency. Installation in series is preferable to attain the better effect.

	Noise level reduction, dB (Octave-frequency band [Hz])							
	63 Hz	125 Hz	250 Hz	500 Hz	1000 Hz	2000 Hz	4000 Hz	8000 Hz
SR 400x200	3	7	10	23	27	30	25	22
SR 500x250	3	6	11	22	26	25	27	22
SR 500x300	3	6	10	23	24	25	23	18
SR 600x300	3	6	10	21	24	30	24	17
SR 600x350	3	5	11	22	25	29	24	21
SR 700x400	4	7	10	15	22	19	21	18
SR 800x500	5	6	11	17	21	20	22	20
SR 900x500	3	6	10	16	20	20	21	15
SR 1000x500	4	6	11	16	21	21	23	17

Designation key:

Series	Flange designation (WxH) [mm]
SR	400x200; 500x250; 500x300; 600x300; 600x350; 700x400; 800x500; 900x500; 1000x500

**Overall dimensions:**

Type	Dimensions [mm]							Mass [kg]
	B	B1	B2	H	H1	H2	L	
SR 400x200	400	420	440	200	220	240	950	18,5
SR 500x250	500	520	540	250	270	290	950	20,5
SR 500x300	500	520	540	300	320	340	950	24,5
SR 600x300	600	620	640	300	320	340	950	26,5
SR 600x350	600	620	640	350	370	390	950	28,7
SR 700x400	700	720	740	400	420	440	1010	36,7
SR 800x500	800	820	840	500	520	540	1010	50,0
SR 900x500	900	920	940	500	520	540	1010	51,7
SR 1000x500	1000	1020	1040	500	520	540	1010	57,3

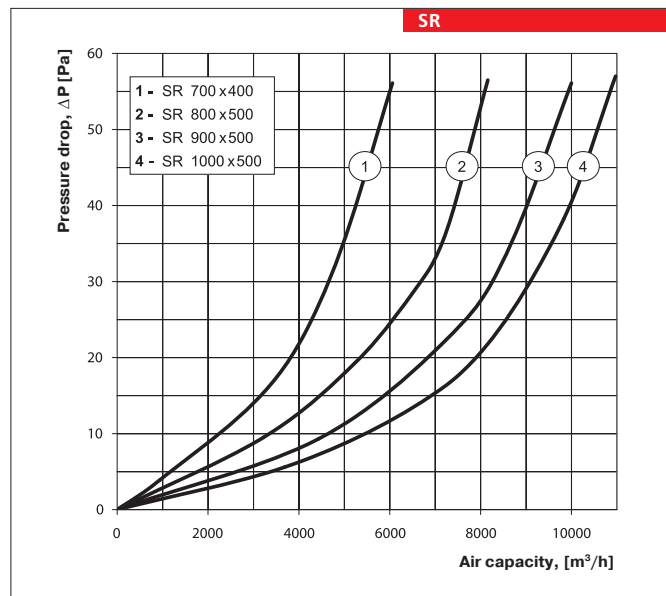
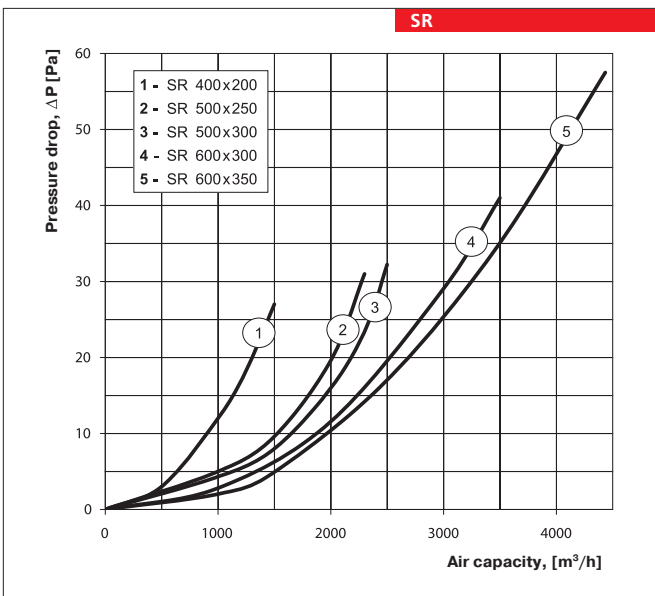
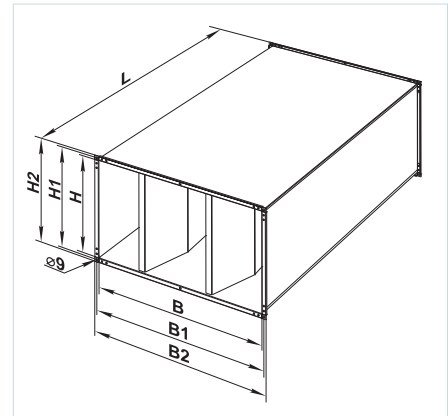

Series  
**FB**



Series  
**FBV**



■ Applications

Panel type air filters are applied for supply air and sometimes extract air purification in round duct ventilating and conditioning systems. Designed for protection of the air ducts, heat exchangers, control equipment and other ventilating equipment against dusting. The filters minimize wall and ceiling pollution near the air diffuser. Coarse filters can be used as first stage purification filters before more efficient filters.

■ Design

The casing is made of galvanized steel. The filtering box has connecting flanges with rubber seals for airtight connection to the air ducts. The swing-out

access door equipped with lever locks provides easy and quick access to the replaceable filtering element. The filtering element is made of non-woven fabric from synthetic fibers and is fixed on the steel frame.

- **FB filter** with flat filtering element (filtering class G4)
- **FBV filter** with V-filtering element with increased filtering area (filtering class G4).

■ Mounting

The filter design ensures its mounting on the round ducts by means of clamps with respect to air flow direction indicated with the pointer on the casing. Access for the fan maintenance shall be provided for the filter cleaning or replacement.

Overall dimensions:

Type	Dimensions [mm]					Mass [kg]
	∅D	B	H	L	L1	
FB 100	99	210	175	215	123	1,4
FB 125	124	220	209	235	143	1,7
FB 150	149	270	237	250	158	2,5
FB 160	159	270	237	250	158	2,3
FB 200	199	320	279	275	183	3,1
FB 250	249	370	327	325	233	4,5
FB 315	314	430	392	425	333	6,7

Overall dimensions:

Type	Dimensions [mm]					Mass [kg]
	∅D	B	H	L	L1	
FBV 100	99	233	175	215	123	1,4
FBV 125	124	243	209	235	143	1,7
FBV 150	149	293	237	250	158	2,2
FBV 160	159	293	237	250	158	2,2
FBV 200	199	343	279	275	183	3,1
FBV 250	249	393	327	325	233	4,2
FBV 315	314	453	392	425	333	6,3

Designation key:

Series	Flange diameter, mm
FB FBV SF SFV	100; 125; 150; 160; 200; 250; 315

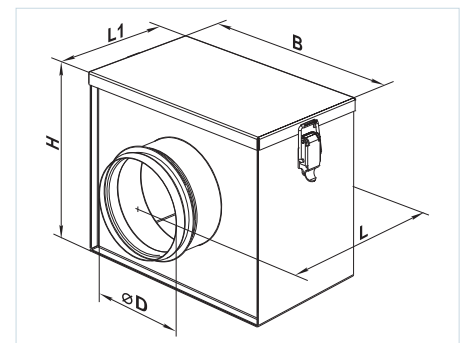
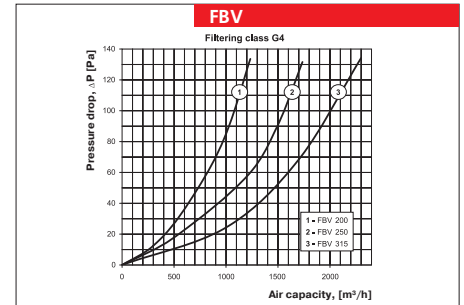
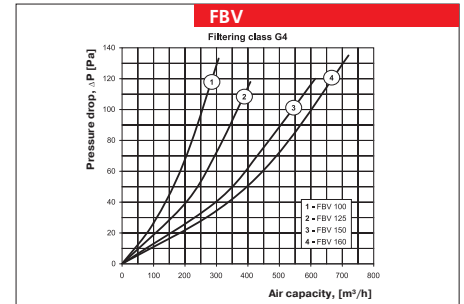
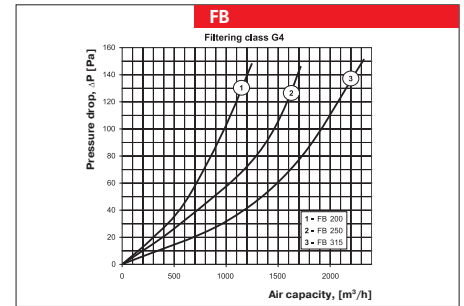
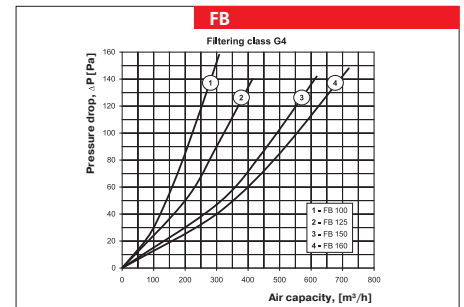

Replaceable filter SF



Replaceable filter SFV





PANEL FILTERS

Series  
**FB**



■ **Applications**

Panel type air filters are applied for supply air and sometimes extract air purification in rectangular duct ventilating and conditioning systems. Designed for protection of the air ducts, heat exchangers, control equipment and other ventilating equipment against dusting. The filters minimize wall and ceiling pollution near the air diffuser. Coarse filters can be used as first stage purification filters before more efficient filters.

■ **Design**

The casing is made of galvanized steel. V-shaped form ensures filtering surface increase. The

filtering element is made of non-woven fabric from synthetic fibers and has protecting metal mesh against deformation caused by air flow. Removable cover equipped with lever locks provides easy and quick access to the replaceable filtering element. The filters are small-sized and are suitable even for limited space. Filtering class G4.

■ **Mounting**

The filters are installed at heater and fan inlet along the air flow direction. The air flow direction shall match the designation on the filter. Access for the fan maintenance shall be provided for the filter cleaning or replacement.

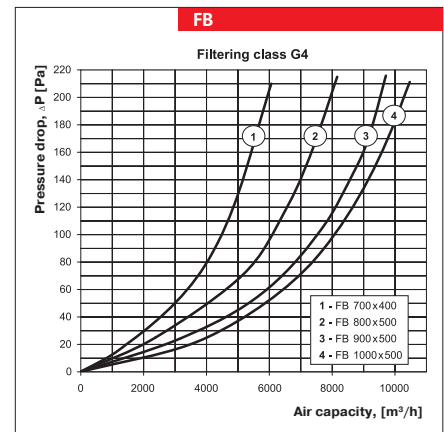
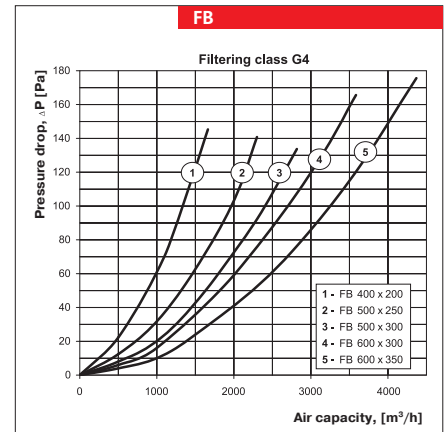

**Overall dimensions:**

Type	Dimensions [mm]						Mass [kg]
	B	B1	B2	H	H1	H2	
FB 400x200	400	420	440	200	220	240	2,4
FB 500x250	500	520	540	250	270	290	4,1
FB 500x300	500	520	540	300	320	340	4,4
FB 600x300	600	620	640	300	320	340	5,2
FB 600x350	600	620	640	350	370	390	5,8
FB 700x400	700	720	740	400	420	440	6,7
FB 800x500	800	820	840	500	520	540	7,9
FB 900x500	900	920	940	500	520	540	8,4
FB 1000x500	1000	1020	1040	500	520	540	8,9

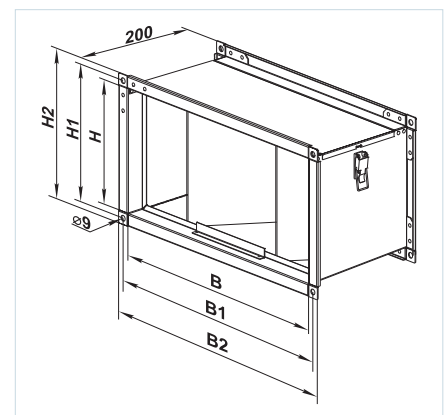

**Designation key:**

Series	Flange designation (WxH) [mm]
FB SF	400x200; 500x250; 500x300; 600x300; 600x350; 700x400; 800x500; 900x500; 1000x500

Replaceable SF filter



Series  
**FBK**



■ **Applications**

Pocket type air filters are applied for supply air and sometimes extract air purification in round duct ventilating and conditioning systems. Designed for protection of the air ducts, heat exchangers, control equipment and other ventilating equipment against dusting. The filters minimize wall and ceiling pollution near the air diffuser. Coarse filters can be used as first stage purification filters before more efficient filters.

■ **Design**

The casing is made of galvanized steel. The filtering box has connecting flanges with rubber seals for airtight connection to the air ducts. The swing-out door equipped with lever locks provides easy and quick access to the replaceable filtering element. The filtering element is made of non-woven fabric from synthetic fibers and is fixed on the galvanized steel frame. The filters are available in G4, F5, F7 filtering class.

■ **Mounting**

The filter design ensures its mounting on the round ducts in any position by means of clamps. The air flow direction shall match the pointer direction on the filter. Both horizontal and vertical mounting is possible. In case of vertical installation the air shall be streamed downwards in such a way as to avoid pockets crumpling. Access for the filter cleaning or replacement shall be provided.

**Overall dimensions:**

Type	Dimensions [mm]				Mass, [kg]
	∅D	B	B1	H	
FBK 100	99	210	230	170	2,41
FBK 125	124	220	240	206	2,69
FBK 150	149	270	290	236	3,20
FBK 160	159	270	290	236	3,26
FBK 200	199	320	340	276	3,76
FBK 250	249	370	390	386	4,39
FBK 315	314	430	450	390	5,17

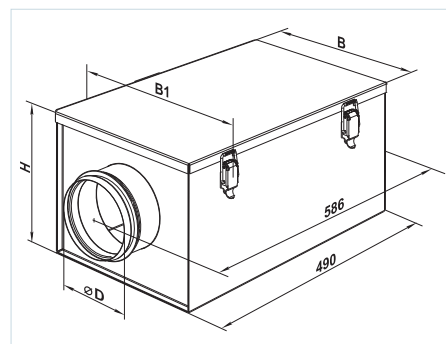

**Designation key:**

Series	Flange diameter, mm	Filtering class
FBK SFK	100; 125; 150; 160; 200; 250; 315	4 – G4 5 – F5 7 – F7

SFK replaceable filter



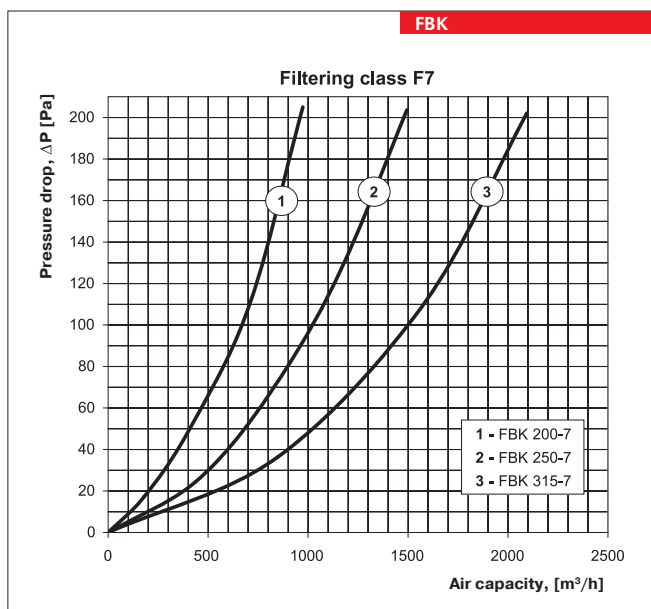
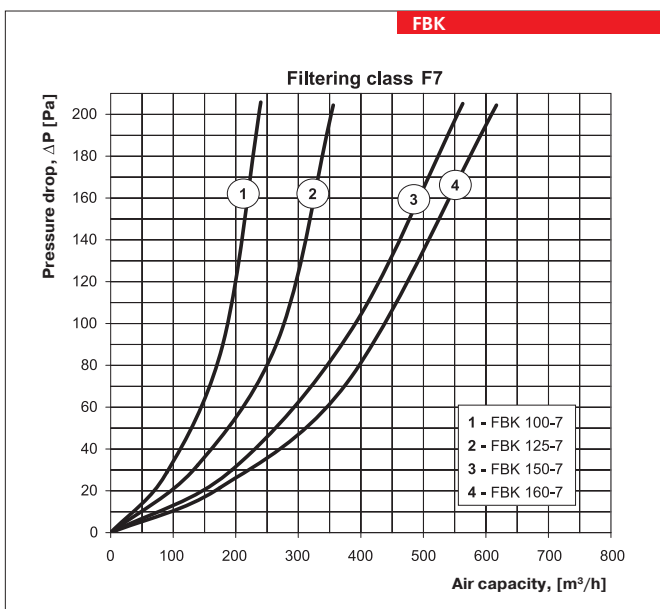
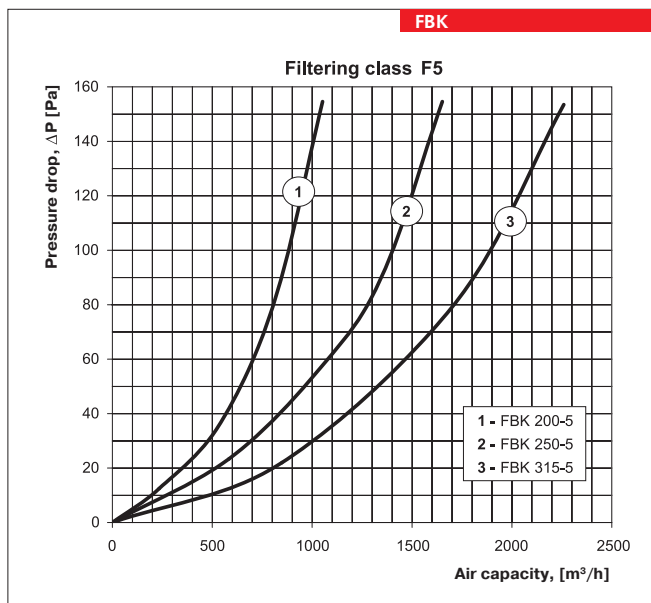
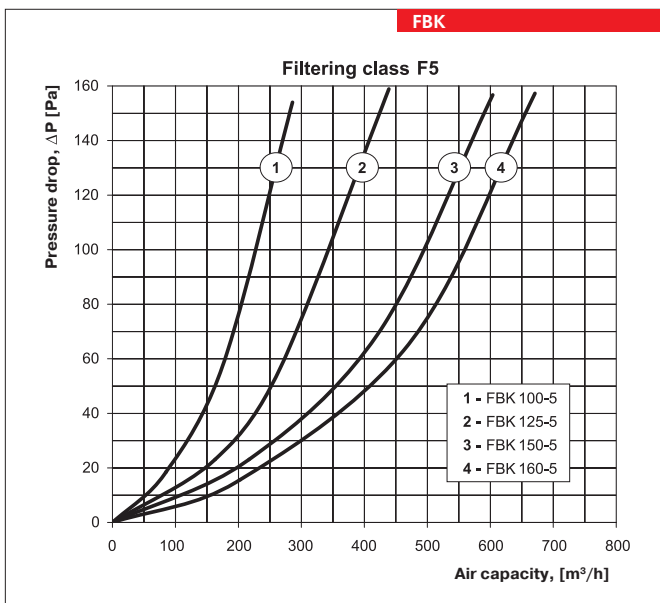
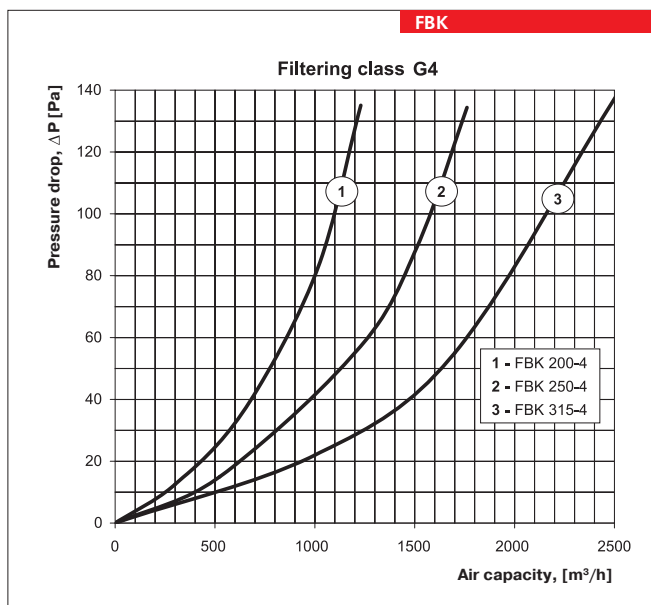
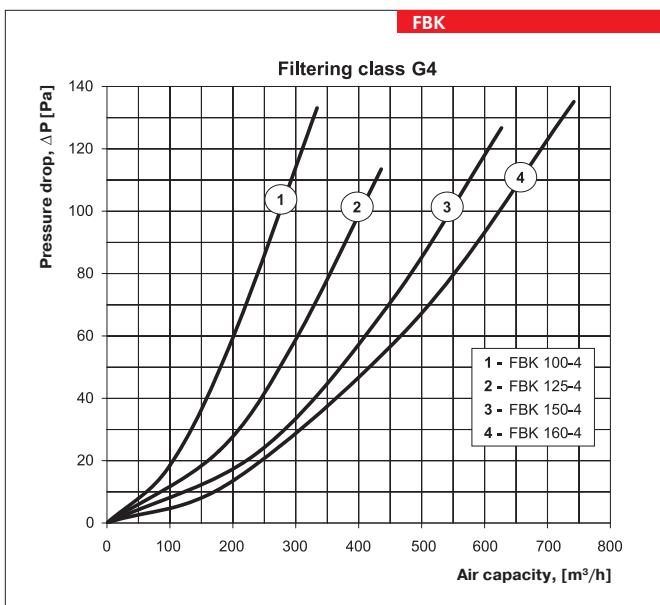

Series  
**FBK**



■ **Applications**

Pocket type air filters are applied for supply air and sometimes for exhaust air purification in rectangular duct ventilating and conditioning systems. They serve to protect air ducts, heat exchangers, control equipment and other ventilating equipment against dusting. The filters minimize wall and ceiling pollution near the air diffuser. Coarse filters can be used as first stage purification filters before more efficient filters.

■ **Design**

The casing is made of galvanized steel. The swing-out cover equipped with lever locks provides easy and quick access to the replaceable filtering element. The pocket-type filtering element is made of non-woven synthetic fibrous fabric and is fixed on the steel frame. The filters are available in G4, F5, F7 filtering classes.

■ **Mounting**

Mounting is performed by means of flange connection. The air flow direction shall match the pointer direction on the filter. Both horizontal and vertical installation is possible. In case of vertical installation the air shall be streamed downwards in such a way as to avoid pockets crumpling. Access for the fan maintenance shall be provided for the filter cleaning or replacement.

**Overall dimensions:**

Type	Dimensions [mm]							Mass, [kg]
	B	B1	B2	H	H1	H2	L	
FBK 400x200	400	420	440	200	220	240	500	6,2
FBK 500x250	500	520	540	250	270	290	600	7,8
FBK 500x300	500	520	540	300	320	340	600	8,3
FBK 600x300	600	620	640	300	320	340	600	8,9
FBK 600x350	600	620	640	350	370	390	600	9,5
FBK 700x400	700	720	740	400	420	440	720	16,2
FBK 800x500	800	820	840	500	520	540	800	20,4
FBK 900x500	900	920	940	500	520	540	800	21,7
FBK 1000x500	1000	1020	1040	500	570	540	800	23,5

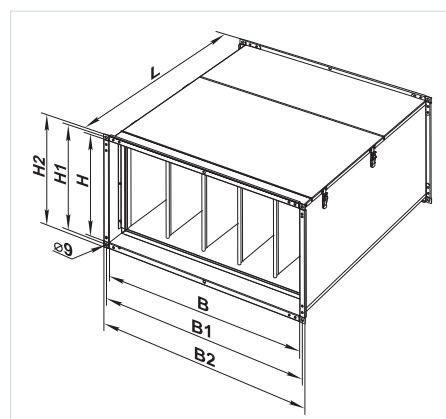

**Designation key:**

Series	Flange designation (WxH) [mm]	Filtering class	Replaceable filter SFK
<b>FBK</b> <b>SFK</b>	400x200; 500x250; 500x300; 600x300; 600x350; 700x400; 800x500; 900x500; 1000x500	4 – G4 5 – F5 7 – F7	

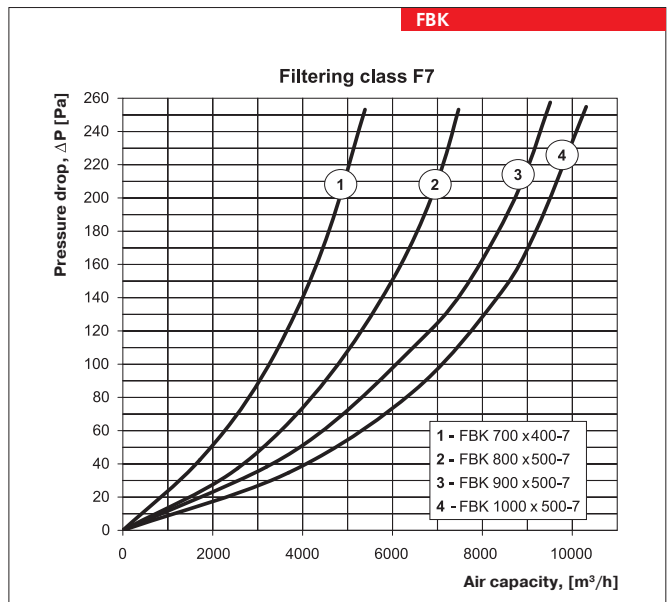
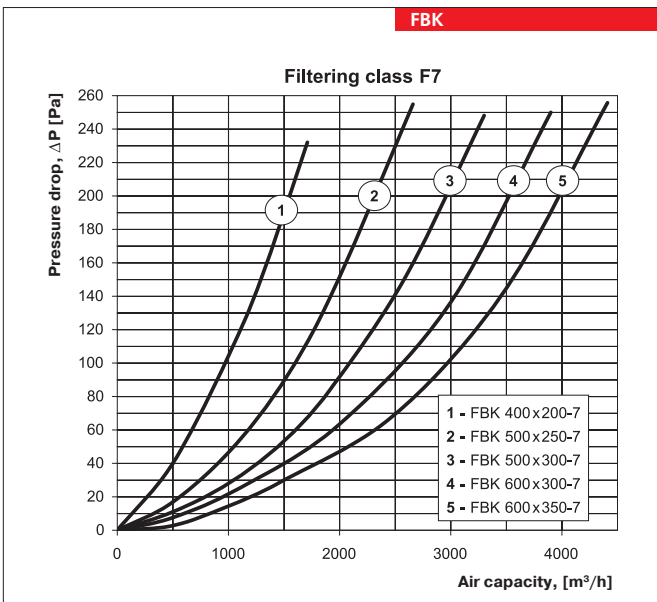
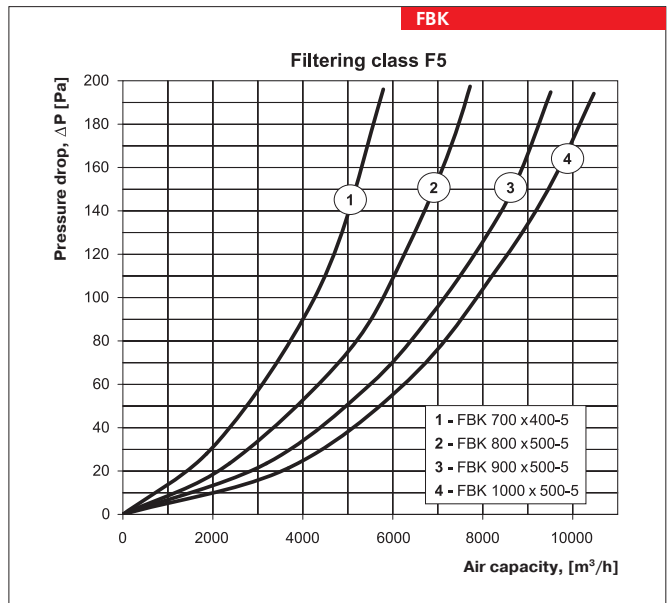
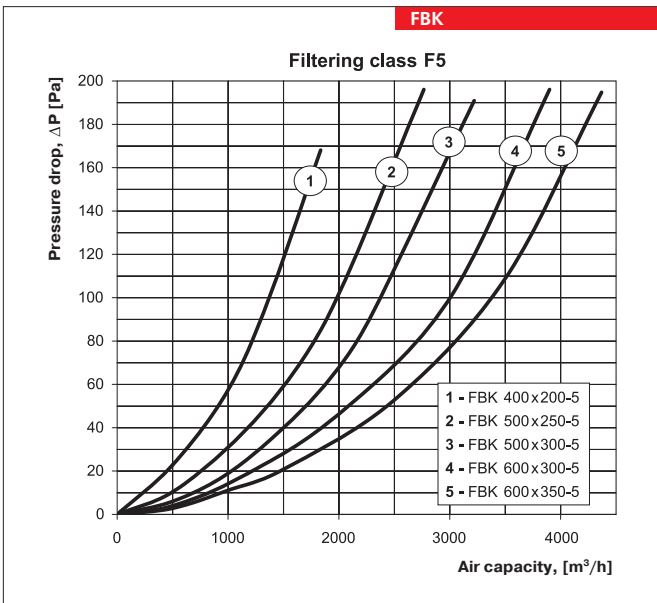
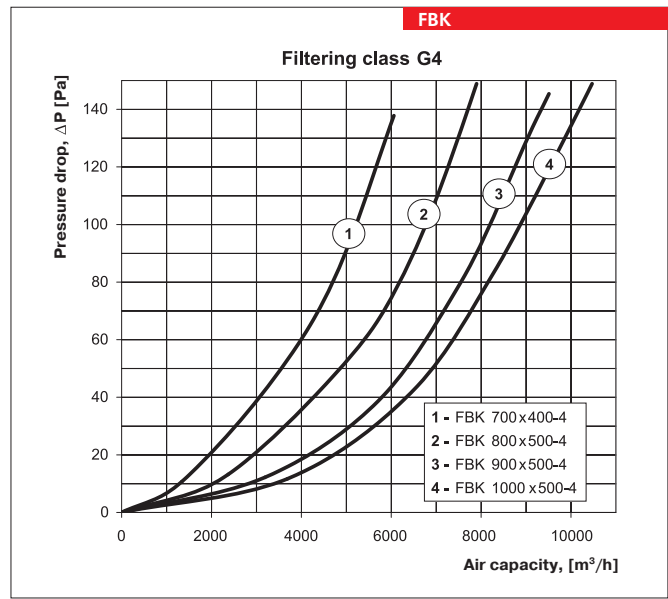
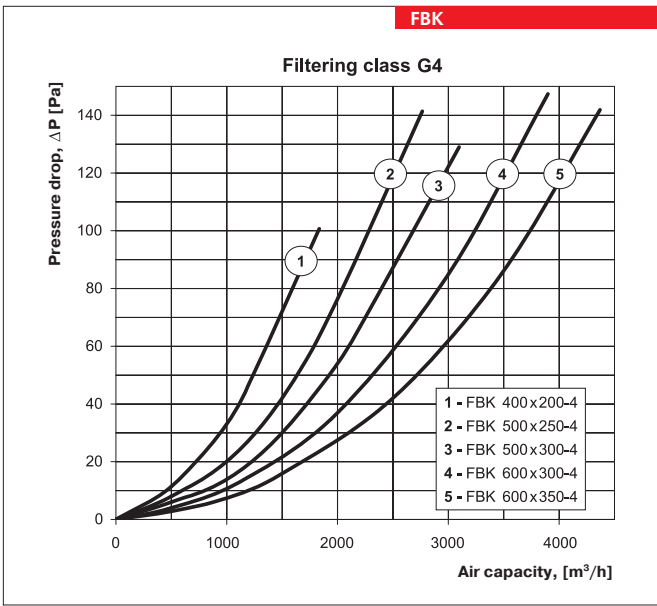



Series  
**NK**



■ **Applications**

Duct electrical heaters are designed for supply air heating in round duct ventilating system. The heaters are applied in heating, ventilation and air conditioning systems for various premises.

■ **Design**

The casing and the terminal box are made of galvanized steel and the heating elements are of stainless steel. The heaters are equipped with rubber seals for connection to the air ducts.

NK duct heaters are equipped with two overheating protection thermostats:

- ▶ basic protection with automatic restart with +50°C operating temperature. After cooling the thermostat closes the control circuit of the heater automatically.
- ▶ emergency protection with manual restart (operating temperature +90°C). In case of response the power supply to the heater is allowed after the manual emergency reset only.

Each standard size has several electric capacity options. The higher capacity can be attained by means of installation of the heaters in series.

■ **Mounting**

- ▶ The heater design ensures its mounting on the round ducts in any position by means of clamps. The air flow direction shall match the pointer on the filter. The duct heaters can be installed in any position except for with the electric control unit below to prevent liquid penetration and wiring short circuit.
- ▶ The mounting shall be performed in such a way as to enable uniform air distribution along the entire cross section.

- ▶ The air filter shall be installed at heater inlet to protect the heating elements against pollution.
- ▶ The minimum distance between the heater and other system elements is no less than two connecting diameters.
- ▶ The duct heaters are designed for minimum air flow speed 1.5 m/s and the maximum operating outlet temperature 40°C. In case of speed control option ensure the minimum air flow through the heater.
- ▶ Power supply to the heater shall be disabled if the fan is not running.
- ▶ To ensure the correct and safe heater operation the automation system can be applied to ensure the complex control and protection:
  - ✓ automatic control of heating elements capacity and air heating temperature;
  - ✓ checking filter condition by means of differential pressure sensor;
  - ✓ power supply disabling in case of supply fan shutdown or airflow speed decrease as well as in case of the built-in overheating thermostats operation;
  - ✓ shutoff of ventilating system with blowing of electrical heating elements.

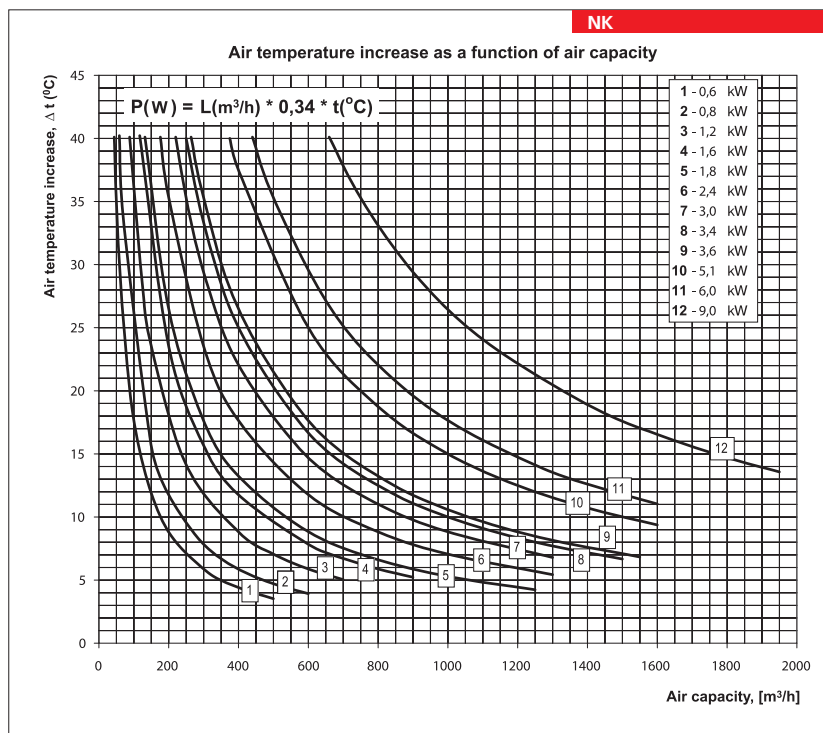

**Designation key:**

Series	Flange diameter, mm	-	Heater power [kW]	-	Phase
NK	100; 125; 150; 160; 200; 250; 315	-	0,6; 0,8; 1,2; 1,6; 1,8; 2,4; 3,4; 3,6; 5,1; 6,0; 9,0	-	1 – single phase; 3 – three phases

**Technical data:**

	Minimum air capacity [m <sup>3</sup> /h]	Current [A]	Voltage [V]	Power [kW]	Number of heating coils x capacity [kW]	Phase
NK 100-0,6-1	60	2,6	230	0,6	1x0,6	1
NK 100-0,8-1	80	3,5	230	0,8	1x0,8	1
NK 100-1,2-1	90	5,2	230	1,2	2x0,6	1
NK 100-1,6-1	120	7,0	230	1,6	2x0,8	1
NK 100-1,8-1	130	7,8	230	1,8	3x0,6	1
NK 125-0,6-1	60	2,6	230	0,6	1x0,6	1
NK 125-0,8-1	80	3,5	230	0,8	1x0,8	1
NK 125-1,2-1	90	5,2	230	1,2	2x0,6	1
NK 125-1,6-1	120	7,0	230	1,6	2x0,8	1
NK 125-2,4-1	150	7,8	230	2,4	3x0,8	1
NK 150-1,2-1	120	5,2	230	1,2	1x1,2	1
NK 150-2,4-1	150	10,4	230	2,4	2x1,2	1
NK 150-3,4-1	220	14,7	230	3,4	2x1,7	1
NK 150-3,6-3	265	5,2	400	3,6	3x1,2	3
NK 150-5,1-3	320	7,4	400	5,1	3x1,7	3
NK 150-6,0-3	360	8,7	400	6,0	3x2,0	3
NK 160-1,2-1	150	5,2	230	1,2	1x1,2	1
NK 160-2,4-1	180	10,4	230	2,4	2x1,2	1
NK 160-3,4-1	250	14,8	230	3,4	2x1,7	1
NK 160-3,6-3	265	5,2	400	3,6	3x1,2	3
NK 160-5,1-3	375	7,4	400	5,1	3x1,7	3
NK 160-6,0-3	440	8,7	400	6,0	3x2,0	3
NK 200-1,2-1	150	5,2	230	1,2	1x1,2	1
NK 200-2,4-1	180	10,4	230	2,4	2x1,2	1
NK 200-3,4-1	250	14,8	230	3,4	2x1,7	1
NK 200-3,6-3	265	5,2	400	3,6	3x1,2	3
NK 200-5,1-3	375	7,4	400	5,1	3x1,7	3
NK 200-6,0-3	440	8,7	400	6,0	3x2,0	3
NK 250-1,2-1	180	5,2	230	1,2	1x1,2	1
NK 250-2,4-1	265	10,4	230	2,4	2x1,2	1
NK 250-3,0-1	375	13,0	230	3,0	1x3,0	1
NK 250-3,6-3	375	5,2	400	3,6	3x1,2	3
NK 250-6,0-3	440	8,7	400	6,0	3x2,0	3
NK 250-9,0-3	660	13,0	400	9,0	3x3,0	3
NK 315-1,2-1	180	5,2	230	1,2	1x1,2	1
NK 315-2,4-1	265	10,4	230	2,4	2x1,2	1
NK 315-3,6-3	375	5,2	400	3,6	3x1,2	3
NK 315-6,0-3	440	8,7	400	6,0	3x2,0	3
NK 315-9,0-3	660	13,0	400	9,0	3x3,0	3

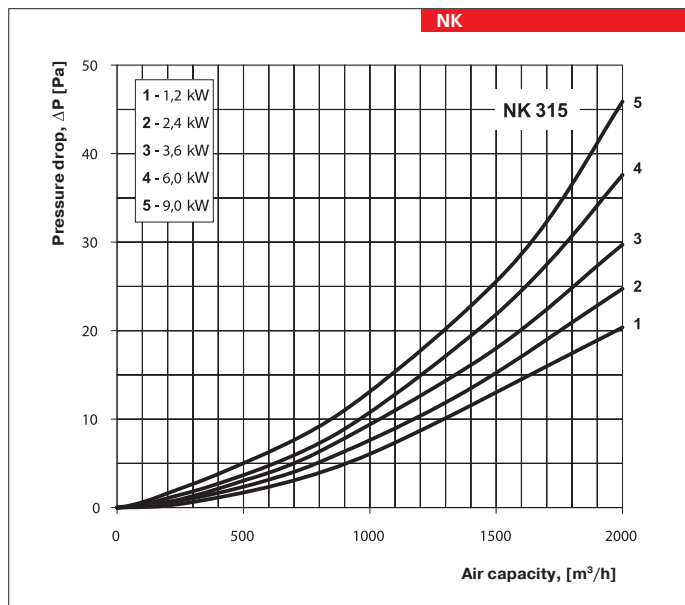
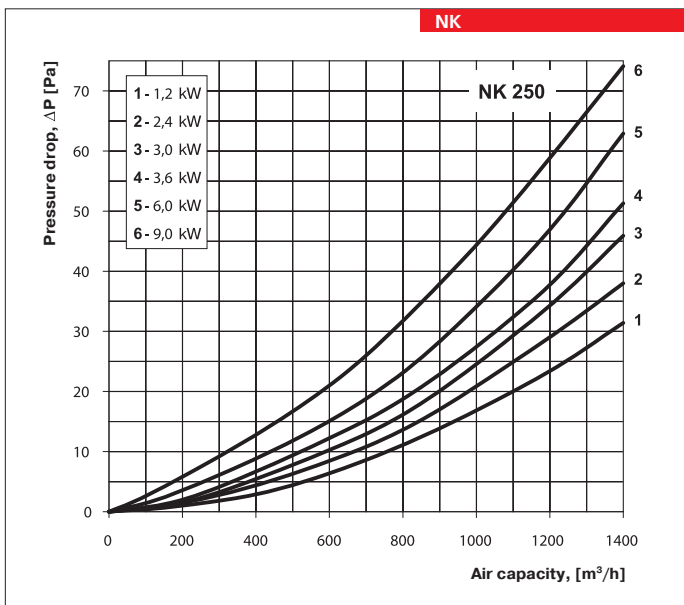
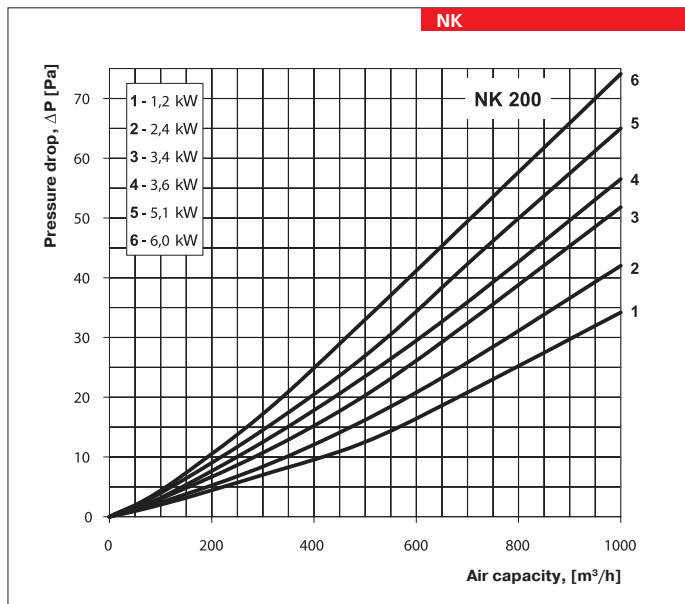
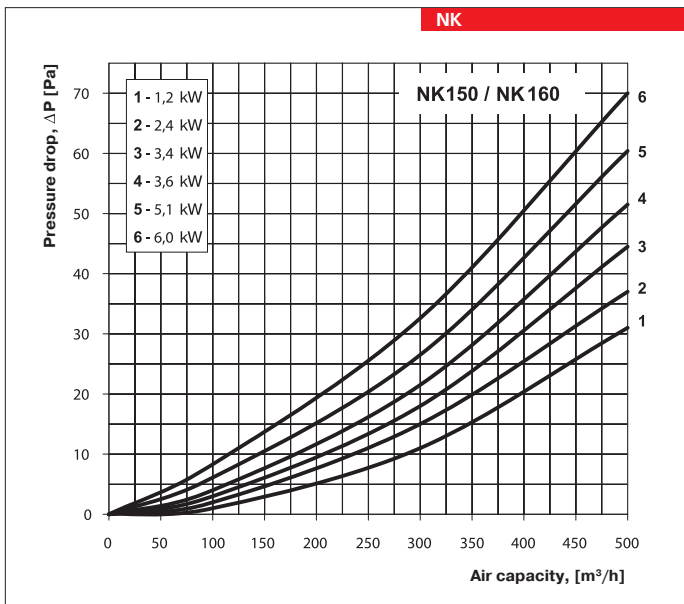
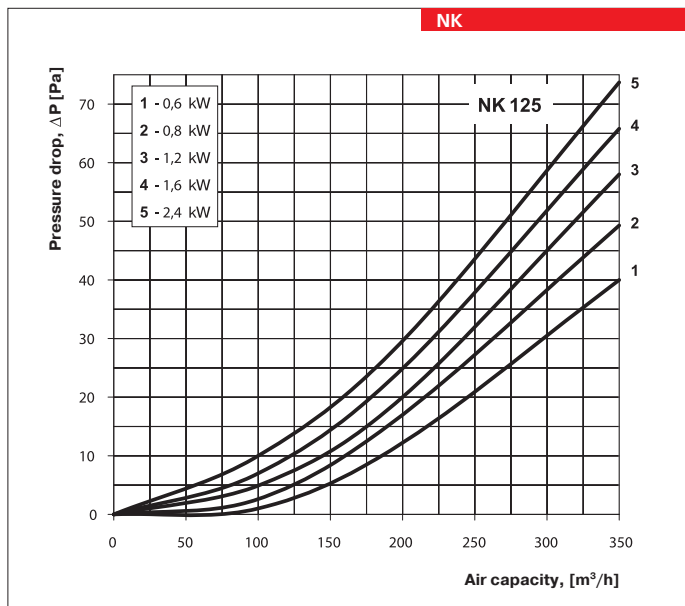
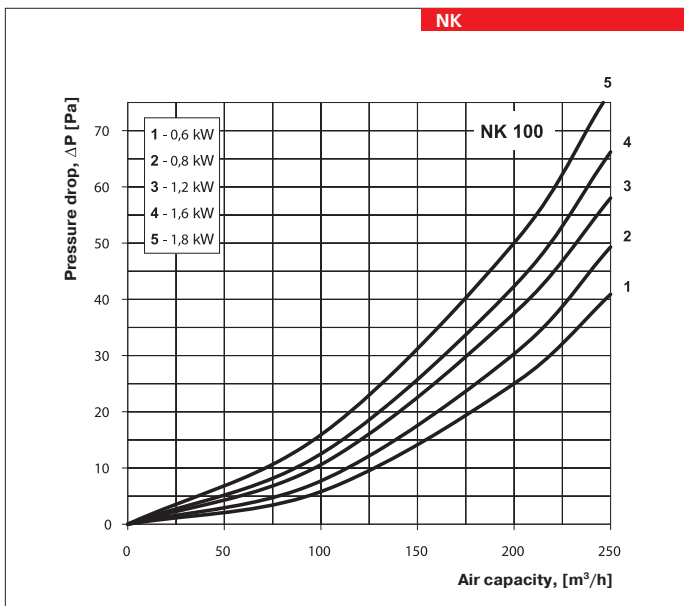

**Overall dimensions:**

Type	Dimensions [mm]						Mass [kg]
	∅D	B	H	L	L1	L2	
NK-100-0,6-1	99	94	207	306	226	40	2,6
NK-100-0,8-1	99	94	207	306	226	40	2,6
NK-100-1,2-1	99	94	207	306	226	40	2,9
NK-100-1,6-1	99	94	207	306	226	40	2,9
NK-100-1,8-1	99	94	207	376	296	40	3,1
NK-125-0,6-1	124	103	230	306	226	40	2,4
NK-125-0,8-1	124	103	230	306	226	40	2,4
NK-125-1,2-1	124	103	230	306	226	40	2,7
NK-125-1,6-1	124	103	230	306	226	40	2,7
NK-125-2,4-1	124	103	230	376	296	40	3,0
NK-150-1,2-1	149	120	255	306	226	40	2,5
NK-150-2,4-1	149	120	255	306	226	40	3,1
NK-150-3,4-1	149	120	255	306	226	40	3,1
NK-150-3,6-3	149	120	255	376	296	40	4,1
NK-150-5,1-3	149	120	255	376	296	40	4,1
NK-150-6,0-3	149	120	255	376	296	40	4,1
NK-160-1,2-1	159	120	267	306	226	40	2,1
NK-160-2,4-1	159	120	267	306	226	40	2,9
NK-160-3,4-1	159	120	267	306	226	40	3,2
NK-160-3,6-3	159	120	267	376	296	40	3,9
NK-160-5,1-3	159	120	267	376	296	40	3,9
NK-160-6,0-3	159	120	267	376	296	40	3,9
NK-200-1,2-1	199	150	302	294	214	40	2,4
NK-200-2,4-1	199	150	302	294	214	40	3,2
NK-200-3,4-1	199	150	302	294	214	40	3,3
NK-200-3,6-3	199	150	302	376	296	40	4,1
NK-200-5,1-3	199	150	302	376	296	40	4,1
NK-200-6,0-3	199	150	302	376	296	40	4,1
NK-250-1,2-1	249	150	356	306	226	40	2,4
NK-250-2,4-1	249	150	356	306	226	40	2,6
NK-250-3,0-1	249	150	356	306	226	40	2,4
NK-250-3,6-3	249	150	356	376	296	40	2,9
NK-250-6,0-3	249	150	356	376	296	40	2,9
NK-250-9,0-3	249	150	356	376	296	40	2,9
NK-315-1,2-1	313	150	425	294	214	40	2,6
NK-315-2,4-1	313	150	425	294	214	40	2,8
NK-315-3,6-3	313	150	425	376	296	40	3,1
NK-315-6,0-3	313	150	425	376	296	40	3,1
NK-315-9,0-3	313	150	425	376	296	40	3,1

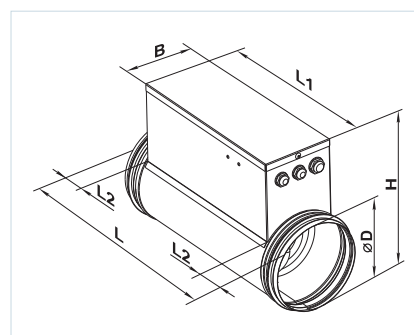

Series  
**NK**



■ **Applications**

Duct electrical heaters are designed for heating of intake air in rectangular ventilating system. The heaters are applied for air heating in ventilation and air conditioning systems in various premises.

■ **Design**

The casing and the terminal box are made of galvanized steel plate and the heating elements are of stainless steel. Additional ribbing is provided to increase the heat

exchange surface. NK duct heaters are equipped with two overheating protection thermostats:

- ▶ basic protection with automatic restart (operating temperature +50°C). After cooling the thermostat closes the control circuit of the heater automatically.
- ▶ emergency protection with manual restart (operating temperature above +90°C). In case of response the power supply to the heater is allowed after the manual emergency reset only.

Each standard size has several electric power capacity options. Higher capacity can be attained by means of installation of the heaters in series.

■ **Mounting**

▶ The heater design ensures its mounting by means of flange connection. The air flow direction shall match the pointer on the filter. The duct heaters can be installed in any position except for with the electric control unit below to prevent condensate penetration and wiring short circuit.

▶ The mounting shall be performed in such a way as to enable the uniform air stream distribution along the entire cross section.

▶ The air filter shall be installed at the heater inlet to protect the heating elements against pollution.

▶ We recommend to keep such distance between the heater and other system elements which is no less than the heater diagonal, i.e. the distance from one angle to another in its air passage part.

▶ The duct heaters are designed for the minimum air flow 1.5 m/s and the operating air temperature 40 °C. In case of speed control option ensure the minimum air flow through the heater.

▶ Power supply to the heater shall be disabled if the fan is not running.

▶ To ensure the correct and safe heater operation the automation system can be applied to ensure the complex control and protection:

- ✓ automatic control of heating elements capacity and air heating temperature;
- ✓ checking filter condition by means of differential pressure sensor;
- ✓ power supply disabling in case of the supply fan shutdown or airflow speed decrease as well as in case of the built-in overheating thermostats operation;
- ✓ shutoff of ventilating system with blowing of electrical heating elements.

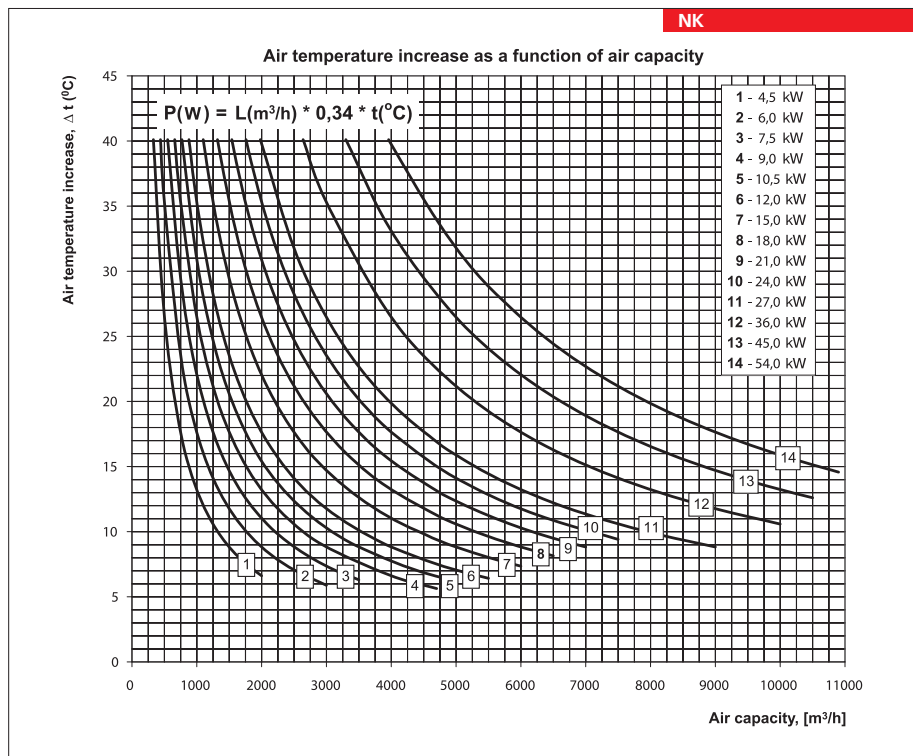

Designation key:

Series	Flange designation (WxH) [mm]	Coil heating capacity [kW]	Phase
NK	400x200; 500x250; 500x300; 600x300; 600x350; 700x400; 800x500; 900x500; 1000x500.	4,5; 6; 7,5; 9; 10,5; 12; 18; 21; 24; 27; 36; 45; 54	3 – three phases

**Technical data:**

	Minimum air capacity [m³/h]	Current [A]	Voltage [V]	Power [kW]	Number of heating coils x capacity [kW]
NK 400x200-4,5-3	330	6,5	400	4,5	3x1,5
NK 400x200-6,0-3	440	8,7	400	6,0	3x2,0
NK 400x200-7,5-3	550	10,9	400	7,5	3x2,5
NK 400x200-9,0-3	660	13,0	400	9,0	3x3,0
NK 400x200-10,5-3	770	15,2	400	10,5	3x3,5
NK 400x200-12,0-3	880	17,4	400	12,0	3x4,0
NK 400x200-15,0-3	1100	21,7	400	15,0	3x5,0
NK 500x250-6,0-3	440	8,7	400	6,0	3x2,0
NK 500x250-7,5-3	550	10,9	400	7,5	3x2,5
NK 500x250-9,0-3	660	13,0	400	9,0	3x3,0
NK 500x250-10,5-3	770	15,2	400	10,5	3x3,5
NK 500x250-12,0-3	880	17,4	400	12,0	3x4,0
NK 500x250-15,0-3	1100	21,7	400	15,0	3x5,0
NK 500x250-18,0-3	1320	26,0	400	18,0	3x6,0
NK 500x250-21,0-3	1540	30,0	400	21,0	3x7,0
NK 500x300-6,0-3	440	8,7	400	6,0	3x2,0
NK 500x300-7,5-3	550	10,9	400	7,5	3x2,5
NK 500x300-9,0-3	660	13,0	400	9,0	3x3,0
NK 500x300-10,5-3	770	15,2	400	10,5	3x3,5
NK 500x300-12,0-3	880	17,4	400	12,0	3x4,0
NK 500x300-15,0-3	1100	21,7	400	15,0	3x5,0
NK 500x300-18,0-3	1320	26,0	400	18,0	3x6,0
NK 500x300-21,0-3	1540	30,0	400	21,0	3x7,0
NK 600x300-9,0-3	660	13,0	400	9,0	3x3,0
NK 600x300-12,0-3	880	17,4	400	12,0	3x4,0
NK 600x300-15,0-3	1100	21,7	400	15,0	3x5,0
NK 600x300-18,0-3	1320	26,0	400	18,0	3x6,0
NK 600x300-21,0-3	1540	30,0	400	21,0	3x7,0
NK 600x300-24,0-3	1760	34,7	400	24,0	3x8,0
NK 600x350-9,0-3	660	13,0	400	9,0	3x3,0
NK 600x350-12,0-3	880	17,4	400	12,0	3x4,0
NK 600x350-15,0-3	1100	21,7	400	15,0	3x5,0
NK 600x350-18,0-3	1320	26,0	400	18,0	3x6,0
NK 600x350-21,0-3	1540	30,0	400	21,0	3x7,0
NK 600x350-24,0-3	1760	34,7	400	24,0	3x8,0
NK 700x400-18-3	1320	26,0	400	18,0	6x3,0
NK 700x400-27-3	1980	39,0	400	27,0	9x3,0
NK 700x400-36-3	2640	52,0	400	36,0	12x3,0
NK 800x500-27-3	1980	39,0	400	27,0	9x3,0
NK 800x500-36-3	2640	52,0	400	36,0	12x3,0
NK 800x500-54-3	3960	78,0	400	54,0	18x3,0
NK 900x500-45-3	3300	65,0	400	45,0	15x3,0
NK 900x500-54-3	3960	78,0	400	54,0	18x3,0
NK 1000x500-45-3	3300	65,0	400	45,0	15x3,0
NK 1000x500-54-3	3960	78,0	400	54,0	18x3,0



# HEATERS

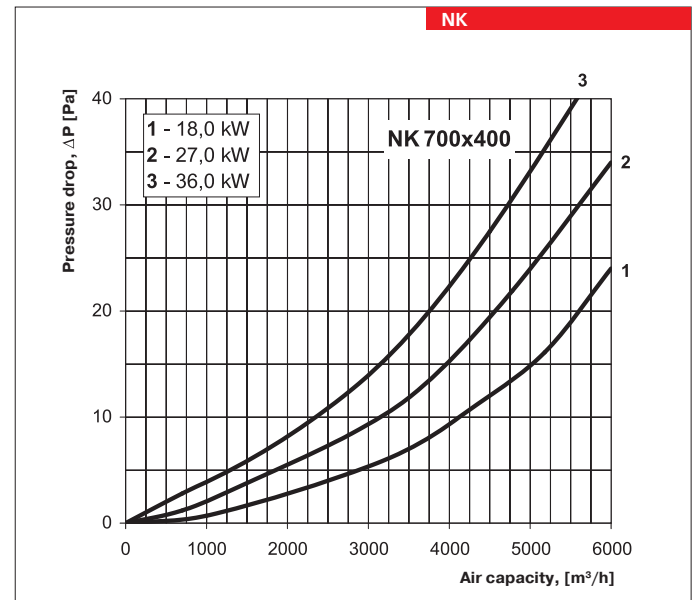
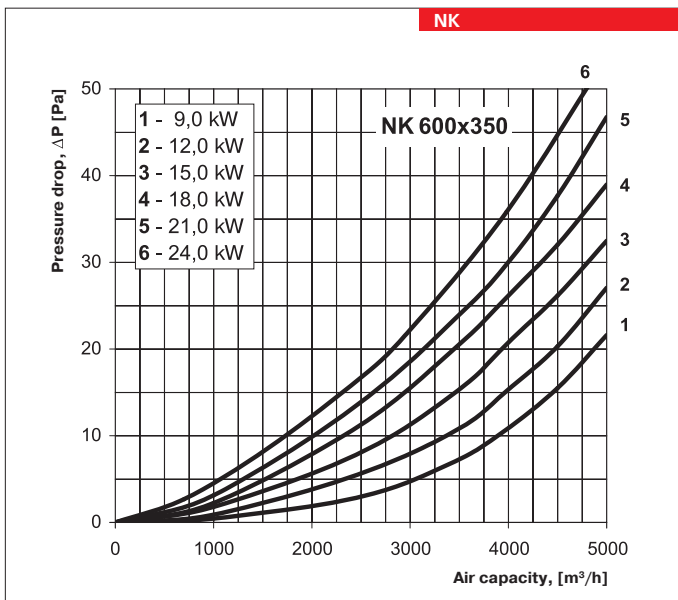
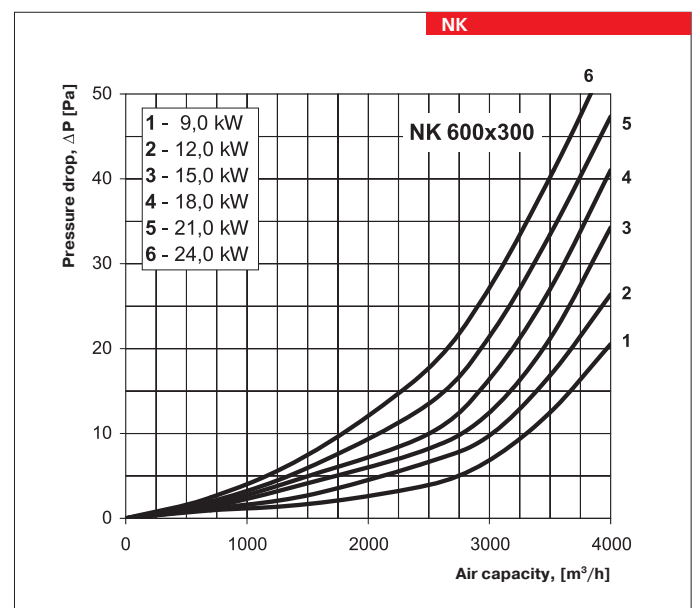
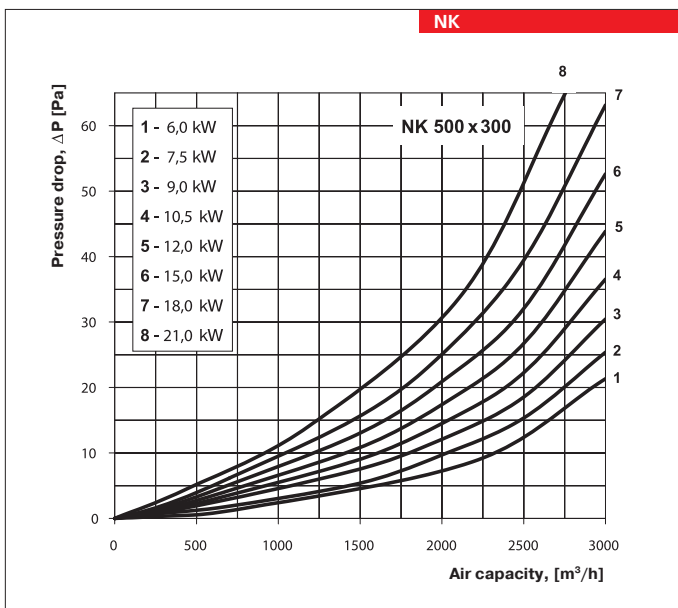
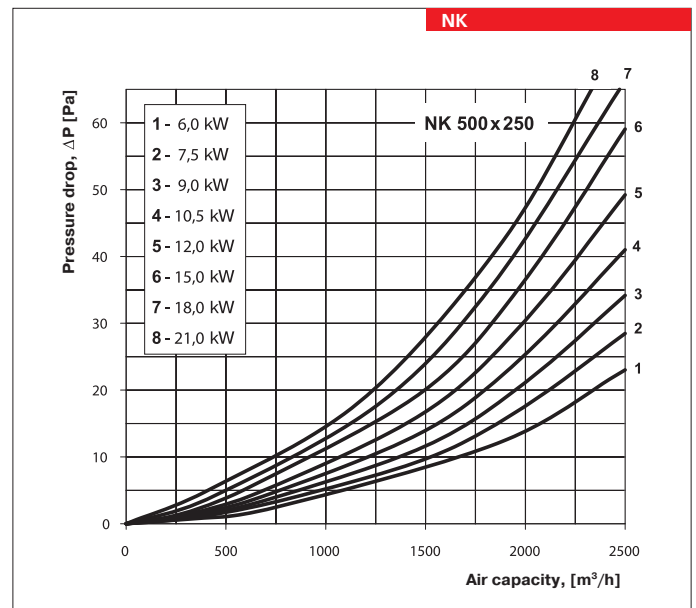
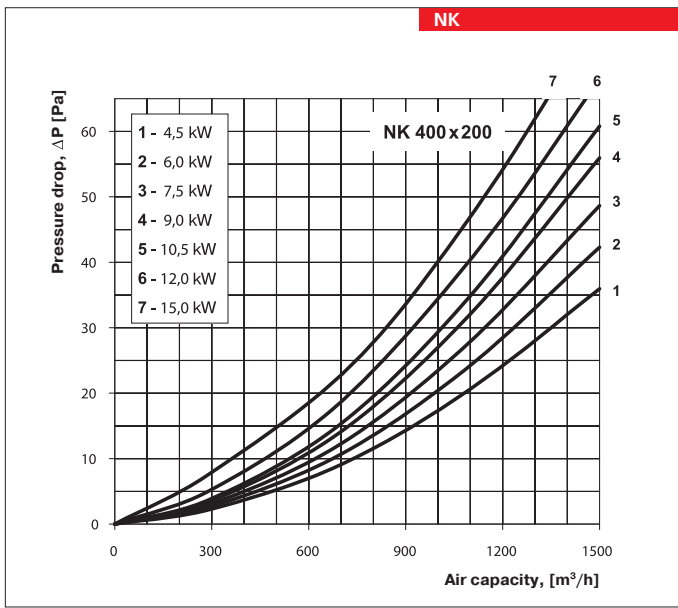

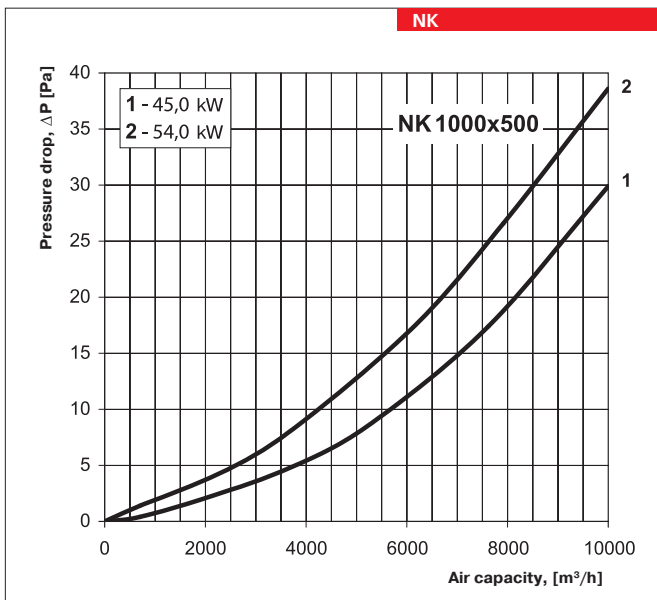
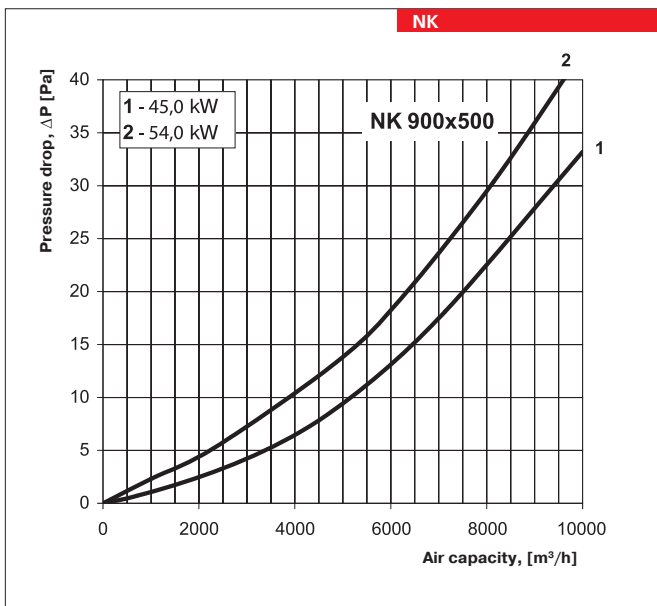
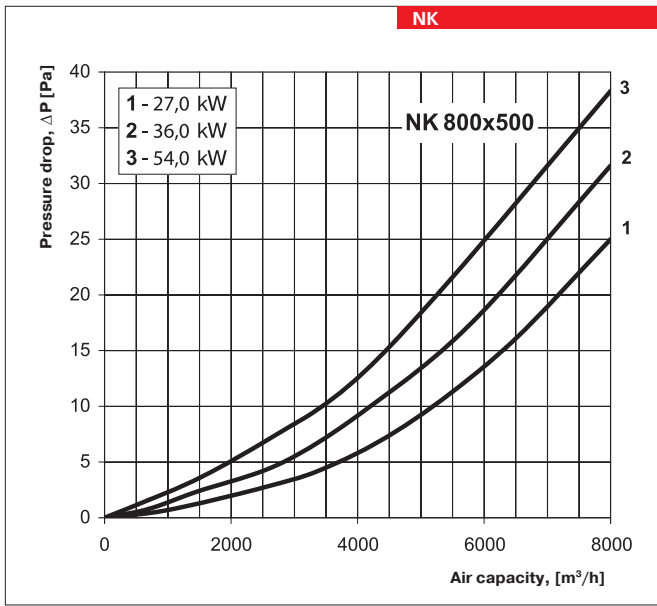

**Overall dimensions:**

Type	Dimensions [mm]								Mass [kg]
	B	B1	B2	B3	H	H1	H2	L	
NK 400x200-4,5-3	400	420	440	540	200	220	240	200	6,5
NK 400x200-6,0-3	400	420	440	540	200	220	240	200	6,5
NK 400x200-7,5-3	400	420	440	540	200	220	240	200	6,5
NK 400x200-9,0-3	400	420	440	540	200	220	240	200	6,5
NK 400x200-10,5-3	400	420	440	540	200	220	240	200	6,5
NK 400x200-12,0-3	400	420	440	540	200	220	240	200	6,5
NK 400x200-15,0-3	400	420	440	540	200	220	240	200	6,5
NK 500x250-6,0-3	500	520	540	640	250	270	290	200	7,65
NK 500x250-7,5-3	500	520	540	640	250	270	290	200	7,65
NK 500x250-9,0-3	500	520	540	640	250	270	290	200	7,65
NK 500x250-10,5-3	500	520	540	640	250	270	290	200	7,65
NK 500x250-12,0-3	500	520	540	640	250	270	290	200	7,65
NK 500x250-15,0-3	500	520	540	640	250	270	290	200	7,65
NK 500x250-18,0-3	500	520	540	640	250	270	290	200	7,65
NK 500x250-21,0-3	500	520	540	640	250	270	290	200	7,65
NK 500x300-6,0-3	500	520	540	640	300	320	340	200	8,2
NK 500x300-7,5-3	500	520	540	640	300	320	340	200	8,2
NK 500x300-9,0-3	500	520	540	640	300	320	340	200	8,2
NK 500x300-10,5-3	500	520	540	640	300	320	340	200	8,2
NK 500x300-12,0-3	500	520	540	640	300	320	340	200	8,2
NK 500x300-15,0-3	500	520	540	640	300	320	340	200	8,2
NK 500x300-18,0-3	500	520	540	640	300	320	340	200	8,2
NK 500x300-21,0-3	500	520	540	640	300	320	340	200	8,2
NK 600x300-9,0-3	600	620	640	740	300	320	340	200	9,4
NK 600x300-12,0-3	600	620	640	740	300	320	340	200	9,4
NK 600x300-15,0-3	600	620	640	740	300	320	340	200	9,4
NK 600x300-18,0-3	600	620	640	740	300	320	340	200	9,4
NK 600x300-21,0-3	600	620	640	740	300	320	340	200	9,4
NK 600x300-24,0-3	600	620	640	740	300	320	340	200	9,4
NK 600x350-9,0-3	600	620	640	740	350	370	390	200	9,75
NK 600x350-12,0-3	600	620	640	740	350	370	390	200	9,75
NK 600x350-15,0-3	600	620	640	740	350	370	390	200	9,75
NK 600x350-18,0-3	600	620	640	740	350	370	390	200	9,75
NK 600x350-21,0-3	600	620	640	740	350	370	390	200	9,75
NK 600x350-24,0-3	600	620	640	740	350	370	390	200	9,75
NK 700x400-18-3	700	720	740	840	400	420	440	390	14
NK 700x400-27-3	700	720	740	840	400	420	440	510	18,5
NK 700x400-36-3	700	720	740	840	400	420	440	750	25
NK 800x500-27-3	800	820	840	940	500	520	540	390	19
NK 800x500-36-3	800	820	840	940	500	520	540	510	23,5
NK 800x500-54-3	800	820	840	940	500	520	540	750	30
NK 900x500-45-3	900	920	940	1040	500	520	540	750	31
NK 900x500-54-3	900	920	940	1040	500	520	540	750	33,5
NK 1000x500-45-3	1000	1020	1040	1140	500	520	540	750	33
NK 1000x500-54-3	1000	1020	1040	1140	500	520	540	750	36

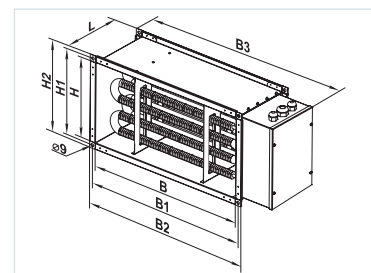

Series  
**NKW**



■ **Applications**

Duct electrical heaters are designed for heating of supply air in round ventilation systems. They can be also applied in supply or supply and exhaust ventilating units.

■ **Design**

The heater casing is made of galvanized steel, the tubular coils are of copper tubes and the heat exchange surface is made of aluminium plates. The heaters are equipped with rubber seals for airtight connection to the air ducts. The heaters are available in 2 and 4 rows modifications and are designed for maximum operating pressure 1.6 MPa (16 bar) and maximum water operating temperature +100°C. The outlet manifold has a branch pipe for installation of submersible temperature probe or icing protecting device. The heater is equipped with a nipple for the system deaeration.

■ **Mounting**

- ▶ The heater design ensures its mounting on the round ducts in any position by means of clamps. The water heating coils can be installed in any position that enables the heater deaeration. The air flow direction shall match the pointer designation on the heater.
- ▶ The mounting shall be performed in such a way as to enable the uniform air stream distribution along the whole cross section.
- ▶ The air filter shall be installed at the heater inlet to protect the heating elements against pollution.
- ▶ The heater can be installed at the fan inlet or outlet. If the heater is located at the filter outlet the air duct between the heater and the filter shall have the length of at least two connecting diameters to ensure the air flow stabilization as well as permissible air temperature level inside the fan.
- ▶ The heater shall be connected on the counterflow principle, otherwise its efficiency can drop by 5-15%.

All the nomographic charts in the catalogue are valid for such connection.

- ▶ If water serves as a heat medium the heaters are suitable for indoor installation only. For outdoor installation use antifreeze mixture, i.e. ethylene glycol solution.
- ▶ To ensure the correct and safe heater operation use the automation system that provides complex control and freezing protection:
  - ✓ automatic control of heating elements capacity and air heating temperature;
  - ✓ Switching ventilating system on after preliminary heating with the heater;
  - ✓ use of air curtains equipped with spring-loaded actuator;
  - ✓ filter checking by means of differential pressure sensor;
  - ✓ fan shutdown in case of the heater freezing danger.

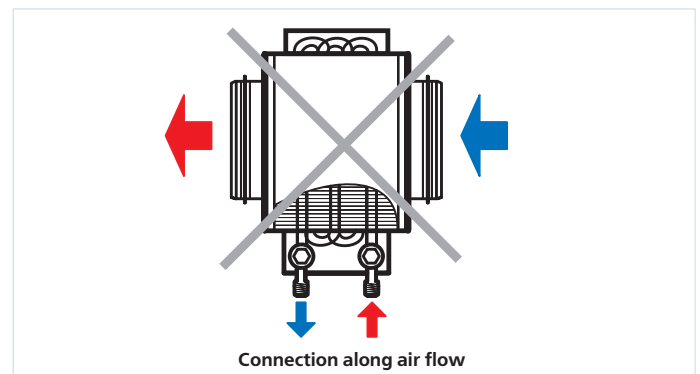
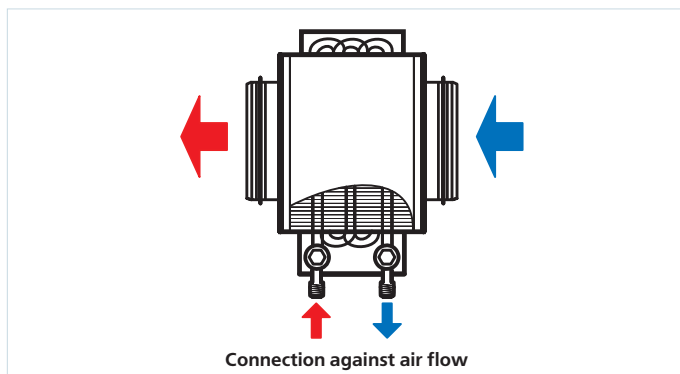

**Designation key:**

Series	Flange diameter, [mm]	–	Number of water coil rows
NKW	100; 125; 150; 160; 200; 250; 315		2; 4

**Accessories**



**Overall dimensions:**

Type	Dimensions [mm]									Number of water coil rows	Mass [kg]
	∅D	B	H	H3	L	L1	L2	L3	K		
NKW 100-2	99	350	230	150	300	32	43	220	G 3/4"	2	3,9
NKW 100-4	99	350	230	150	300	28	65	220	G 3/4"	4	5,2
NKW 125-2	124	350	230	150	300	32	43	220	G 3/4"	2	4,0
NKW 125-4	124	350	230	150	300	28	65	220	G 3/4"	4	5,3
NKW 150-2	149	400	280	200	300	32	43	220	G 3/4"	2	7,5
NKW 150-4	149	400	280	200	300	28	65	220	G 3/4"	4	8,2
NKW 160-2	159	400	280	200	300	32	43	220	G 3/4"	2	7,5
NKW 160-4	159	400	280	200	300	28	65	220	G 3/4"	4	8,2
NKW 200-2	198	400	280	200	300	32	43	220	G 3/4"	2	7,5
NKW 200-4	198	400	280	200	300	28	65	220	G 3/4"	4	8,2
NKW 250-2	248	470	350	270	350	32	43	270	G 1"	2	10,3
NKW 250-4	248	470	350	270	350	28	65	270	G 1"	4	10,8
NKW 315-2	313	550	430	350	450	57	43	370	G 1"	2	12,6
NKW 315-4	313	550	430	350	450	53	65	370	G 1"	4	13,4

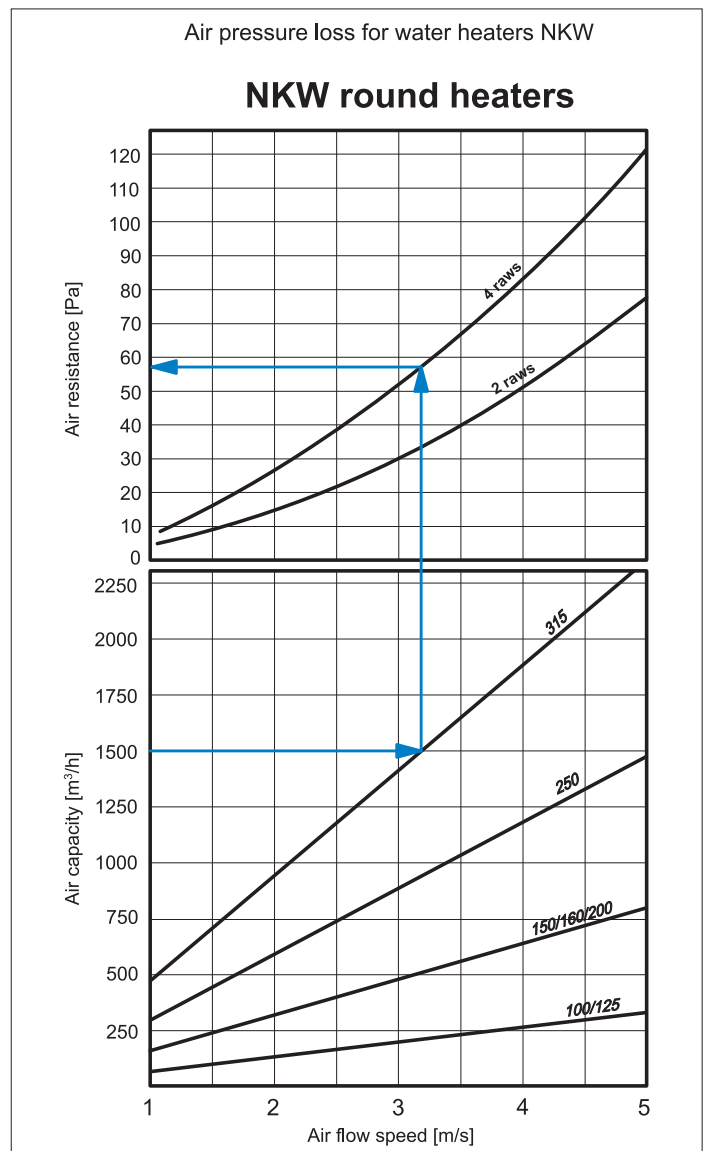
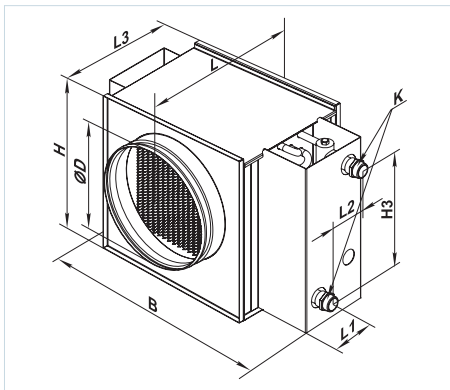

NKW HEATER

NKW

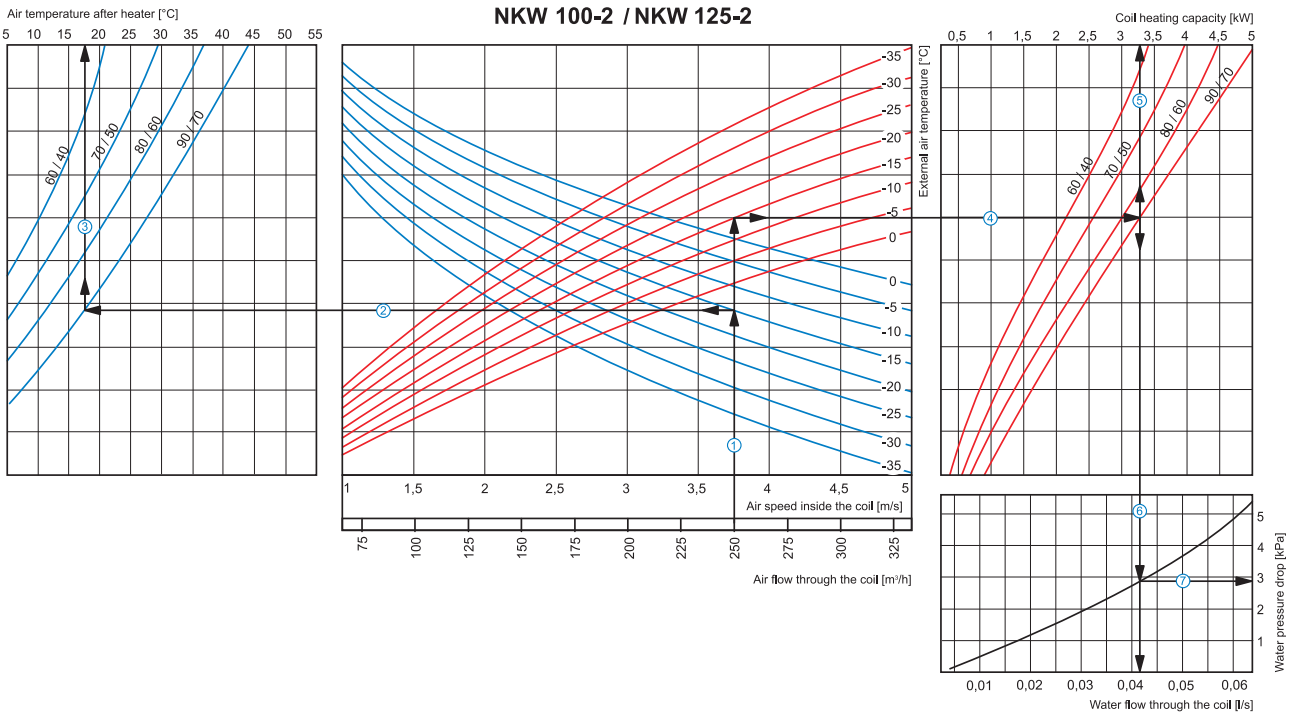

**How to use water heater diagrams**

- Air Speed. Starting from 250 m<sup>3</sup>/h on the air flow scale draw a vertical line ① till the air speed axis which makes about 3.75 m/s.
- Supply air temperature. Prolong the line ① up to the point where it crosses the outside air temperature (blue curve), e.g. -15°C; then draw a horizontal line ② from this point to the left till crossing water in/out temperature curve (90/70 °C). From this point draw a vertical line ③ to the supply air temperature axis on top of the graphic (+17,5°C).
- Heating coil capacity. Prolong the line ① up to the point where it crosses the outside air temperature -15°C (red curve) and draw a horizontal line ④ from this point to the right until it crosses water in/out temperature curve (90/70 °C), from here draw a vertical line ⑤ up to the scale representing the heating coil capacity (3.25 kW).
- Water flow. Prolong the line ⑤ down to water flow axis at the bottom of the graphic (0.042 l/s).
- Water pressure drop. Draw the line ⑦ from the point where line ⑥ crosses the black curve to the pressure drop axis. (2.9 kPa).

NKW

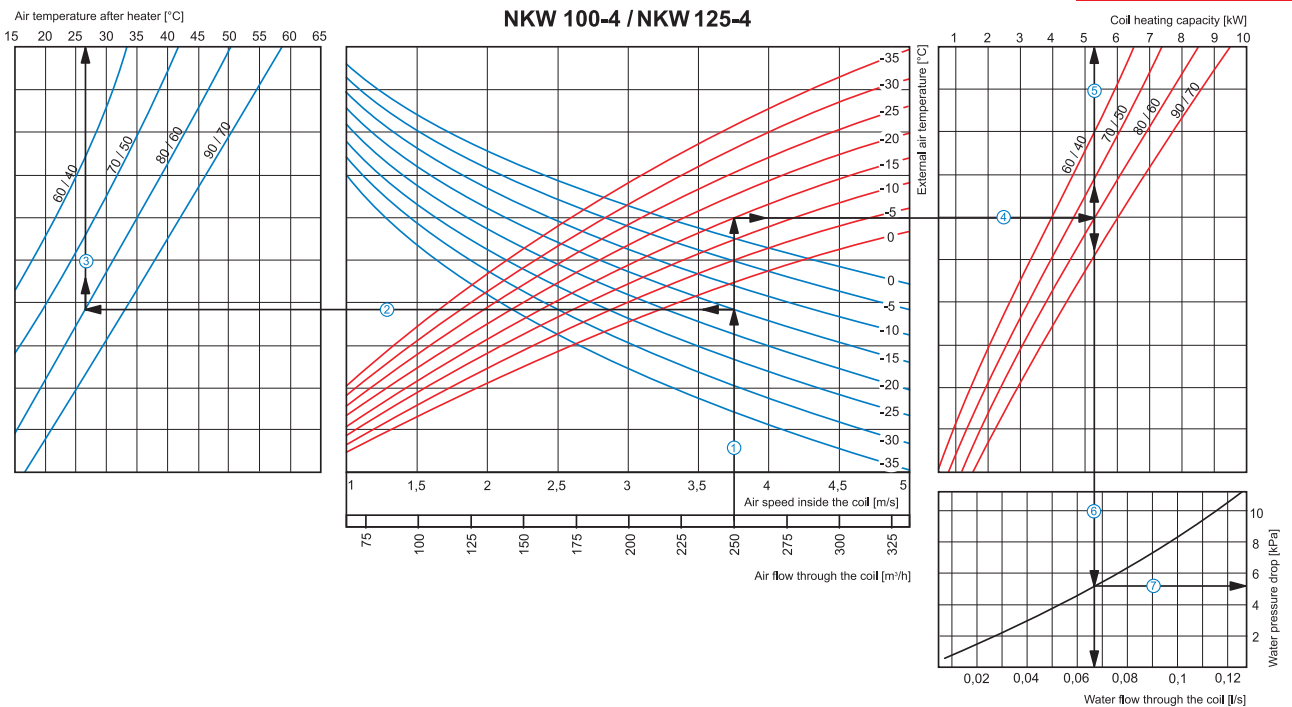

**How to use water heater diagrams**

- Air Speed. Starting from 250 m<sup>3</sup>/h on the air flow scale draw a vertical line ① till the air speed axis which makes about 3.75 m/s.
- Supply air temperature. Prolong the line ① up to the point where it crosses the outside air temperature (blue curve), e.g. -15°C; then draw a horizontal line ② from this point to the left till crossing water in/out temperature curve (80/60 °C). From this point draw a vertical line ③ to the supply air temperature axis on top of the graphic (+27°C).
- Heating coil capacity. Prolong the line ① up to the point where it crosses the outside air temperature indicated as red curve (e.g., -15°C) and draw a horizontal line ④ from this point to the right to the intersection of water in/out temperature curve (e.g., 90/70 °C). From this point draw a vertical line ⑤ up to the scale of heating coil capacity (5.2 kW).
- Water flow. Prolong the line ⑤ down to water flow axis at the bottom of the graphic (0.067 l/s).
- Water pressure drop. Draw the line ⑦ from the point where line ⑥ crosses the black curve to the pressure drop axis. (5.2 kPa).

**NKW**

Air temperature after heater [°C]

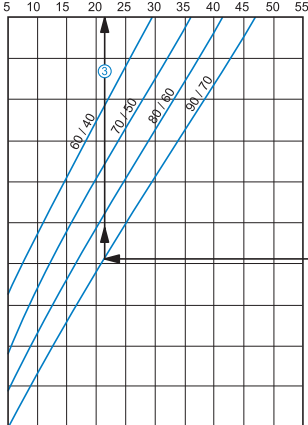

**NKW 150-2 / NKW 160-2 / NKW 200-2**

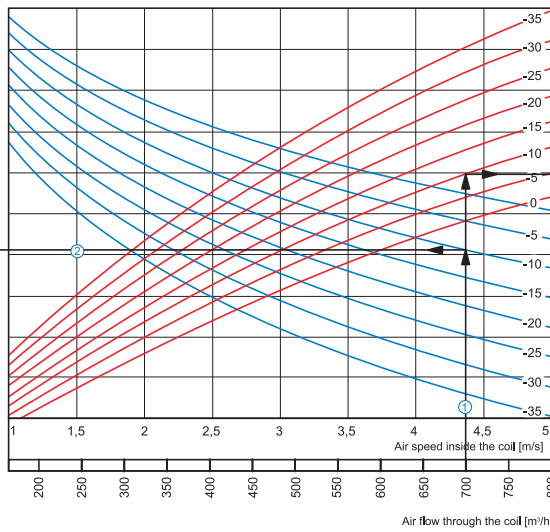

Coil heating capacity [kW]

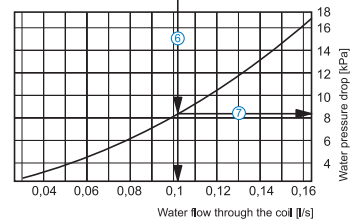
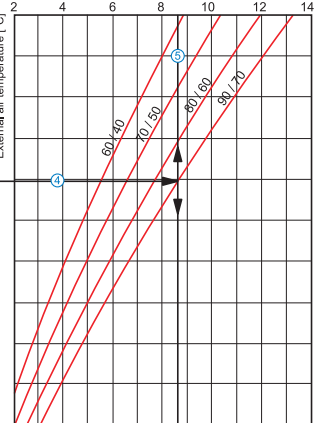

**How to use water heater diagrams**

**Air Speed.** Starting from 700 m<sup>3</sup>/h on the air flow scale draw a vertical line ① till the air speed axis which makes about 4.4 m/s.

■ **Supply air temperature.** Prolong the line ① up to the point where it crosses the outside air temperature (blue curve), e.g. -10°C; then draw a horizontal line ② from this point to the left till crossing water in/out temperature curve (90/70 °C). From this point draw a vertical line ③ to the supply air temperature axis on top of the graphic (+21 °C).

■ **Heating coil capacity.** Prolong the line ① up to the point where it crosses the outside air temperature indicated as red curve (e.g., -10°C) and draw a horizontal line ④ from this point to the right to the intersection of water in/out temperature curve (e.g., 90/70 °C). From this point draw a vertical line ⑤ up to the scale of heating coil capacity (8.6 kW).

■ **Water flow.** Prolong the line ⑥ down to water flow axis at the bottom of the graphic (0.11 l/s).

■ **Water pressure drop.** Draw the line ⑦ from the point where line ⑥ crosses the black curve to the pressure drop axis. (8.2 kPa).

**NKW**

Air temperature after heater [°C]

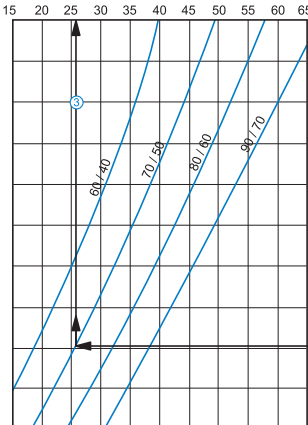

**NKW 150-4 / NKW 160-4 / NKW 200-4**

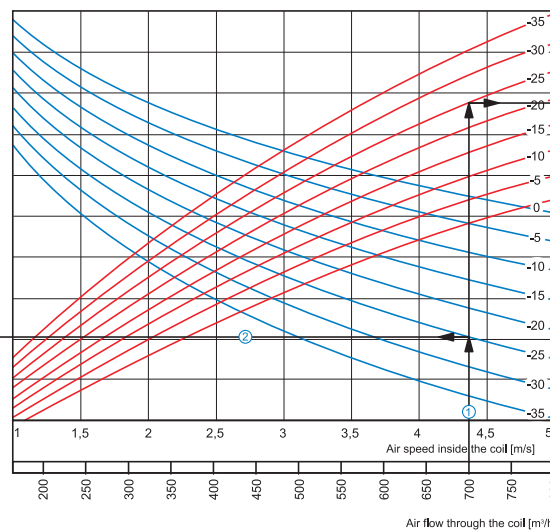

Coil heating capacity [kW]

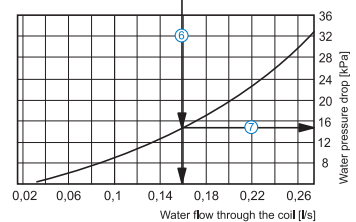
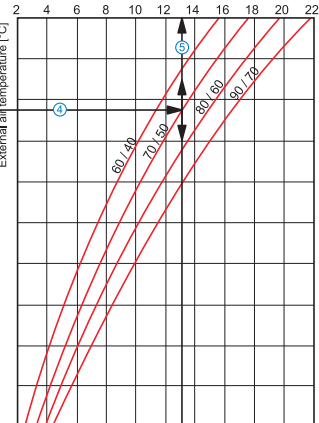

**How to use water heater diagrams**

**Air Speed.** Starting from 700 m<sup>3</sup>/h on the air flow scale draw a vertical line ① till the air speed axis which makes about 4.4 m/s.

■ **Supply air temperature.** Prolong the line ① up to the point where it crosses the outside air temperature (blue curve), e.g. -15°C; then draw a horizontal line ② from this point to the left till crossing water in/out temperature curve (70/50 °C). From this point draw a vertical line ③ to the supply air temperature axis on top of the graphic (+26 °C).

■ **Heating coil capacity.** Prolong the line ① up to the point where it crosses the outside air temperature indicated as red curve (e.g., -25°C) and draw a horizontal line ④ from this point to the right to the intersection of water in/out temperature curve (e.g., 70/50 °C). From this point draw a vertical line ⑤ up to the scale of heating coil capacity (13.0 kW).

■ **Water flow.** Prolong the line ⑥ down to water flow axis at the bottom of the graphic (0.16 l/s).

■ **Water pressure drop.** Draw the line ⑦ from the point where line ⑥ crosses the black curve to the pressure drop axis. (15 kPa).



NKW

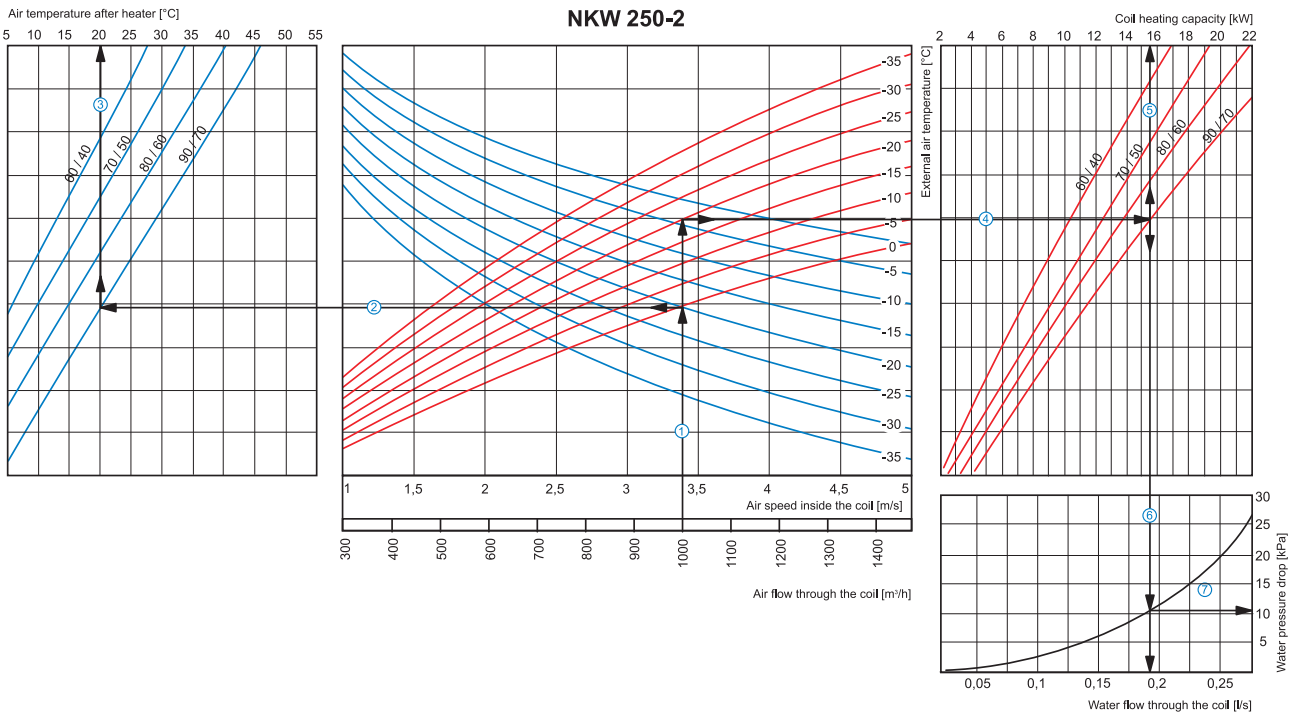

**How to use water heater diagrams**

**Air Speed.** Starting from 1500 m<sup>3</sup>/h on the air flow scale draw a vertical line ① till the air speed axis which makes about 3.4 m/s.

- **Supply air temperature.** Prolong the line ① up to the point where it crosses the outside air temperature (blue curve), e.g. -20°C; then draw a horizontal line ② from this point to the left till crossing water in/out temperature curve (90/70 °C). From this point draw a vertical line ③ to the supply air temperature axis on top of the graphic (+20 °C).
- **Heating coil capacity.** Prolong the line ① up to the point where it crosses the outside air temperature indicated as red curve (e.g., -20°C) and draw a horizontal line ④ from this point to the right to the intersection of water in/out temperature curve (e.g., 90/70 °C). From this point draw a vertical line ⑤ up to the scale of heating coil capacity (15.5 kW).
- **Water flow.** Prolong the line ⑤ down to water flow axis at the bottom of the graphic ⑥ (0.19 l/s).
- **Water pressure drop.** Draw the line ⑦ from the point where line ⑥ crosses the black curve to the pressure drop axis. (11.0 kPa)

NKW

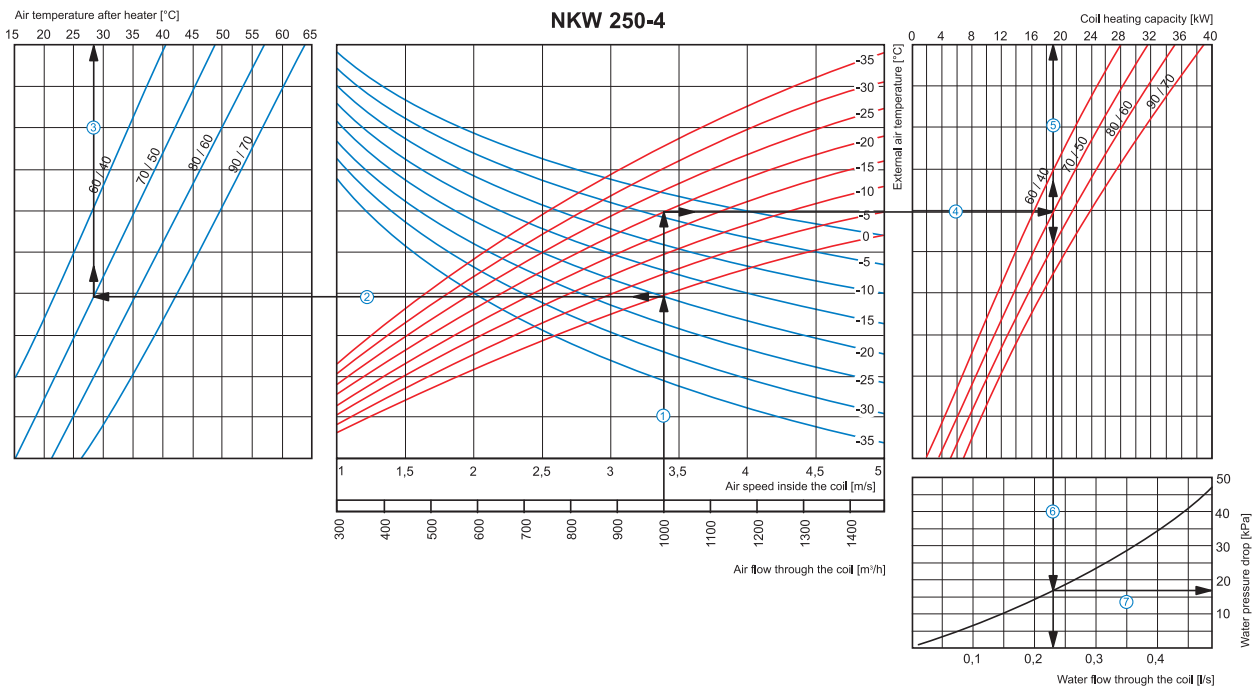

**How to use water heater diagrams**

**Air Speed.** Starting from 1000 m<sup>3</sup>/h on the air flow scale draw a vertical line ① till the air speed axis which makes about 3.4 m/s.

- **Supply air temperature.** Prolong the line ① up to the point where it crosses the outside air temperature (blue curve), e.g. -20°C; then draw a horizontal line ② from this point to the left till crossing water in/out temperature curve (70/50 °C). From this point draw a vertical line ③ to the supply air temperature axis on top of the graphic (+28 °C).
- **Heating coil capacity.** Prolong the line ① up to the point where it crosses the outside air temperature indicated as red curve (e.g., -20°C) and draw a horizontal line ④ from this point to the right to the intersection of water in/out temperature curve (e.g., 70/50 °C). From this point draw a vertical line ⑤ up to the scale of heating coil capacity (19.0 kW).
- **Water flow.** Prolong the line ⑤ down to water flow axis at the bottom of the graphic ⑥ (0.23 l/s).
- **Water pressure drop.** Draw the line ⑦ from the point where line ⑥ crosses the black curve to the pressure drop axis. (17.0 kPa).

**NKW**

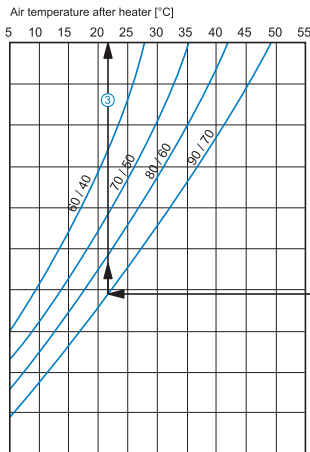

**NKW 315-2**

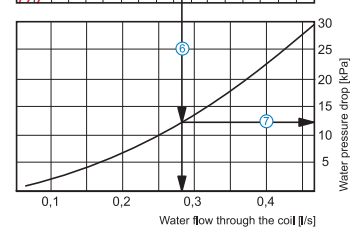
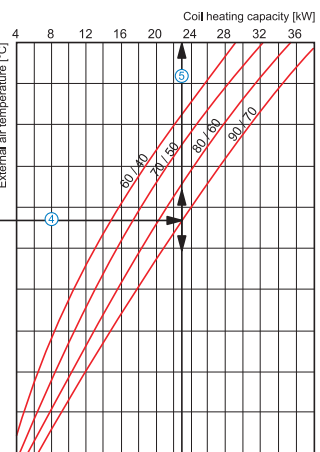
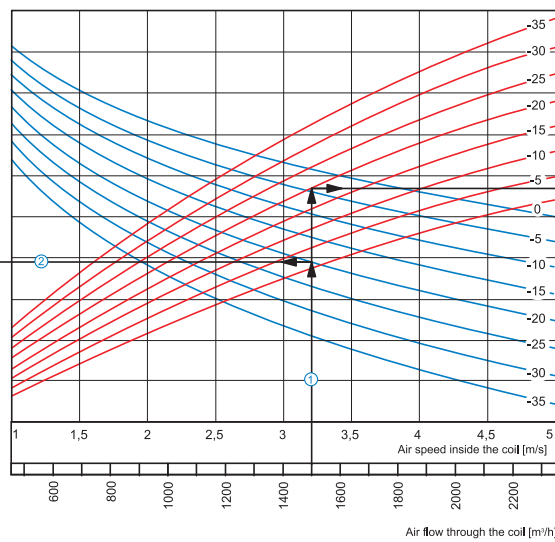

**How to use water heater diagrams**

**Air Speed.** Starting from 1500 m<sup>3</sup>/h on the air flow scale draw a vertical line ① till the air speed axis which makes about 3.2 m/s.

■ **Supply air temperature.** Prolong the line ① up to the point where it crosses the outside air temperature (blue curve), e.g. -20°C, then draw a horizontal line ② from this point to the left till crossing water in/out temperature curve (90/70 °C). From this point draw a vertical line ③ to the supply air temperature axis on top of the graphic (+21 °C).

■ **Heating coil capacity.** Prolong the line ① up to the point where it crosses the outside air temperature (e.g. -20°C, red curve) and draw a horizontal line ④ from this point to the right until it crosses water in/out temperature curve (e.g., 90/70 °C), from here draw a vertical line ⑤ up to the scale representing the heating coil capacity (23.0 kW).

■ **Water flow.** Prolong the line ⑤ down to water flow axis at the bottom of the graphic ⑥ (0.28 l/s)

■ **Water pressure drop.** Draw the line ⑦ from the point where line ⑥ crosses the black curve to the pressure drop axis. (12.5 kPa).

**NKW**

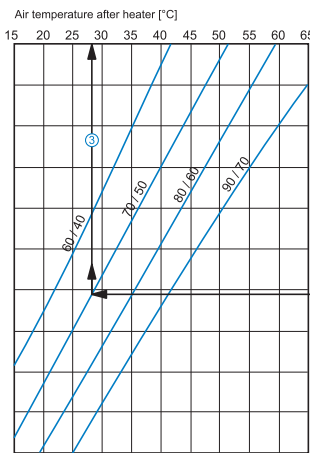

**NKW 315-4**

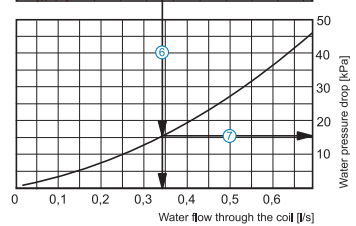
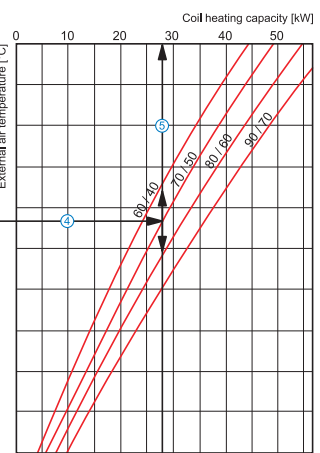
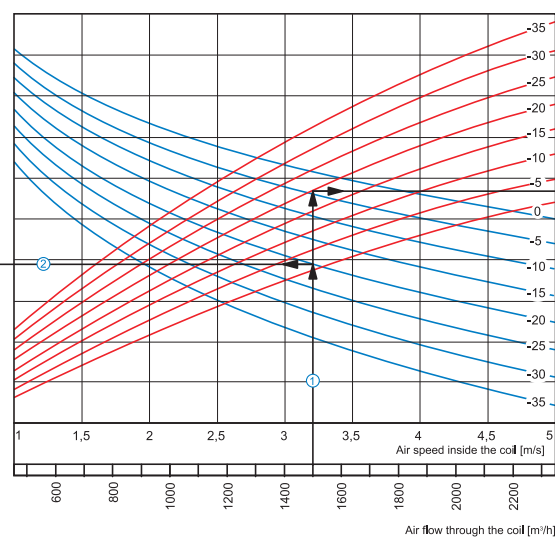

**How to use water heater diagrams**

**Air Speed.** Starting from 1500 m<sup>3</sup>/h on the air flow scale draw a vertical line ① till the air speed axis which makes about 3.2 m/s.

■ **Supply air temperature.** Prolong the line ① up to the point where it crosses the outside air temperature (blue curve), e.g. -20°C; then draw a horizontal line ② from this point to the left till crossing water in/out temperature curve (70/50 °C). From this point draw a vertical line ③ to the supply air temperature axis on top of the graphic (+28 °C).

■ **Heating coil capacity.** Prolong the line ① up to the point where it crosses the outside air temperature (e.g. -20°C, red curve) and draw a horizontal line ④ from this point to the right until it crosses water in/out temperature curve (e.g., 70/50 °C), from here draw a vertical line ⑤ up to the scale representing the heating coil capacity (28.0 kW).

■ **Water flow.** Prolong the line ⑤ down to water flow axis at the bottom of the graphic ⑥ (0.34 l/s).

■ **Water pressure drop.** Draw the line ⑦ from the point where line ⑥ crosses the black curve to the pressure drop axis. (16.0 kPa).

Heater series  
**NKW**



■ **Applications**

Duct electrical heaters are designed for heating of supply air in rectangular ventilating system and are applicable in supply or supply and exhaust units.

■ **Design**

The heater casing is made of galvanized steel, the manifold is made of copper tubes and the heat exchange surface is made of aluminium plates. The heaters are available in 2, 3 or 4 rows modifications and designed for operation at maximum operating pressure 1,6 MPa (16 bar) and maximum operating temperature +100°C. The exhaust manifold of the heater has a branch pipe for submersible temperature sensor or iicng protecting device. The heater has a nipple to provide the system deaeration.

■ **Mounting**

- ▶ The heater design ensures its mounting by means of a flange connection. The water heater can be installed in any position to enable its deaeration. The air stream shall match the pointer on the heater;
- ▶ The heater shall be installed in such a way as to enable the uniform air distribution along the entire cross section;
- ▶ the air filter shall be installed at the heater inlet to provide protection against dust and dirt;
- ▶ the heater can be installed both at the fan inlet or outlet. If the heater is located at the fan outlet the air duct length between the heater and the fan shall be at least 1-1.5 m to ensure the air flow stabilization as well as permissible air temperature level inside the fan;
- ▶ The heater shall be connected on the counterflow principle, otherwise its efficiency can drop by 5-15%. All the nomographic charts in the catalogue are valid for such connection;

- ▶ If waters serves as a heat transfer agent the heaters are designed for indoor installation only. For outdoor installation use antifreeze mixture (i.e. ethylene glycol solution);
- ▶ To ensure the correct and safe heater operation use the automation system that provides the complex control and freezing protection:
  - ✓ automatic control of heating elements capacity and air heating temperature;
  - ✓ Switching ventilating system on with preliminary heating by the heater;
  - ✓ use of air curtains equipped with spring-loaded actuator;
  - ✓ filter checking by means of differential pressure sensor;
  - ✓ fan shutdown in case of water coils freezing danger.

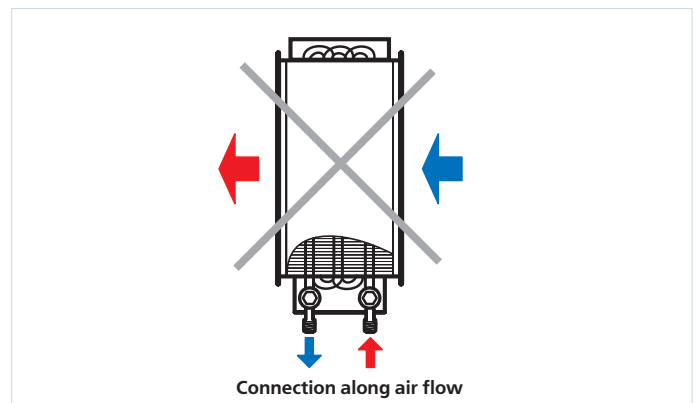
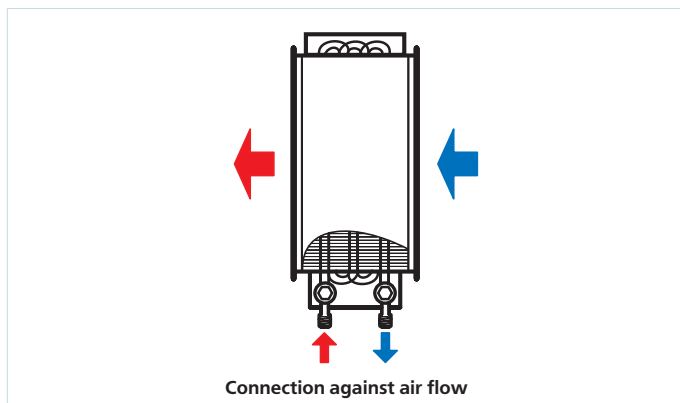

Designation key:

Series	Flange designation (WxH) [mm]	Number of water coil rows
NKW	400x200; 500x250; 500x300; 600x300; 600x350; 700x400; 800x500; 900x500; 1000x500	2; 3; 4

Accessories



page 280

**Overall dimensions:**

Type	Dimensions [mm]												Number of water coil rows	Mass [kg]
	B	B1	B2	B3	H	H1	H2	H3	L	L1	L2	K		
NKW 400x200-2	400	420	440	565	200	220	240	150	200	43	43	G 3/4"	2	7,6
NKW 400x200-4	400	420	440	565	200	220	240	150	200	38	65	G 3/4"	4	8,1
NKW 500x250-2	500	520	540	665	250	270	290	200	200	43	43	G 3/4"	2	15,8
NKW 500x250-4	500	520	540	665	250	270	290	200	200	38	65	G 3/4"	4	16,3
NKW 500x300-2	500	520	540	665	300	320	340	250	200	43	43	G 1"	2	11,5
NKW 500x300-4	500	520	540	665	300	320	340	250	200	38	65	G 1"	4	12,0
NKW 600x300-2	600	620	640	765	300	320	340	250	200	43	43	G 1"	2	21,8
NKW 600x300-4	600	620	640	765	300	320	340	250	200	38	65	G 1"	4	22,3
NKW 600x350-2	600	620	640	765	350	370	390	300	200	43	43	G 1"	2	22,4
NKW 600x350-4	600	620	640	765	350	370	390	300	200	38	65	G 1"	4	22,9
NKW 700x400-2	700	720	740	865	400	420	440	350	200	36	47	G 1"	2	27,8
NKW 700x400-3	700	720	740	865	400	420	440	350	200	42	58	G 1"	3	28,4
NKW 800x500-2	800	820	840	965	500	520	540	450	200	36	47	G 1"	2	36,5
NKW 800x500-3	800	820	840	965	500	520	540	450	200	42	58	G 1"	3	37,2
NKW 900x500-2	900	920	940	1065	500	520	540	450	200	36	47	G 1"	2	40,4
NKW 900x500-3	900	920	940	1065	500	520	540	450	200	42	58	G 1"	3	41,2
NKW 1000x500-2	1000	1020	1040	1165	500	520	540	450	200	36	47	G 1"	2	44,3
NKW 1000x500-3	1000	1020	1040	1165	500	520	540	450	200	42	58	G 1"	3	45,2

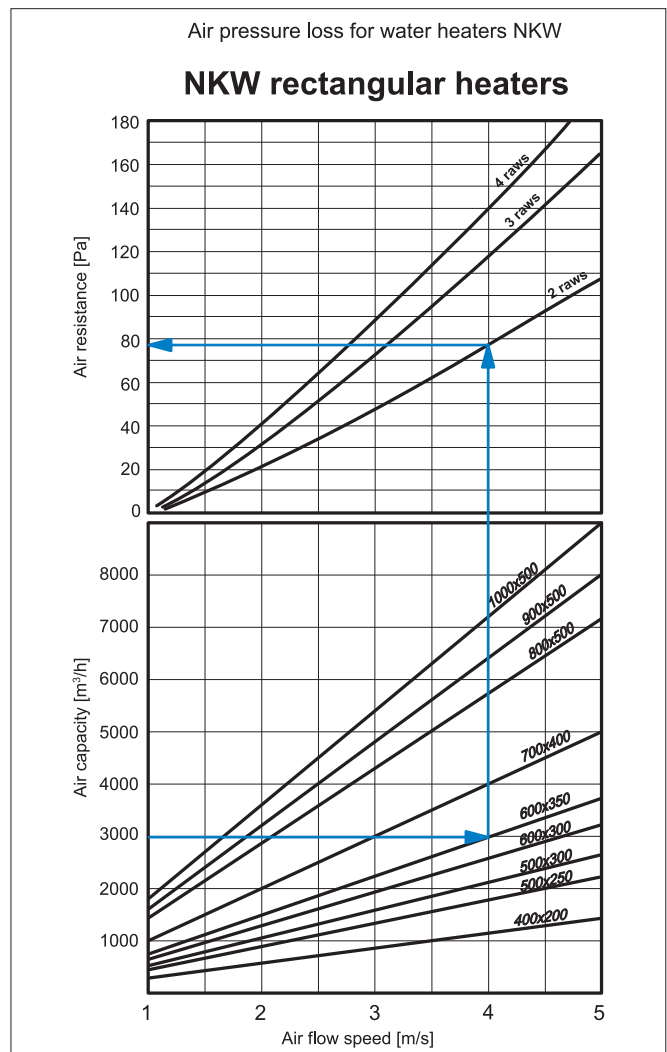
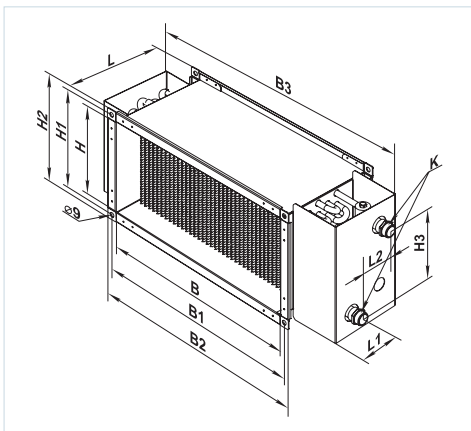

NKW HEATER

NKW

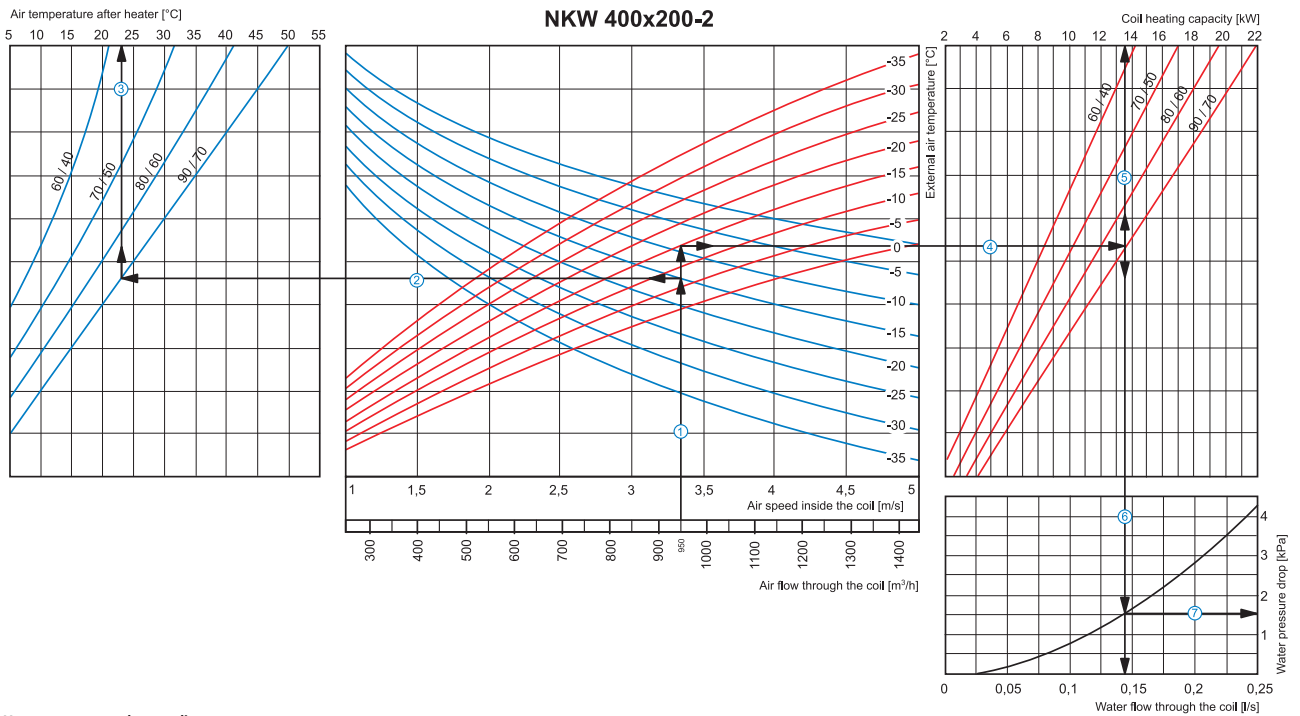

**How to use water heater diagrams**

- Air Speed. Starting from 950 m<sup>3</sup>/h on the air flow scale draw a vertical line ① till the air speed axis which makes about 3.35 m/s.
- Supply air temperature. Prolong the line ① up to the point where it crosses the outside air temperature (blue curve), e.g. -15°C; then draw a horizontal line ② from this point to the left till crossing water in/out temperature curve (90/70 °C). From this point draw a vertical line ③ to the supply air temperature axis on top of the graphic (+23°C).
- Heating coil capacity. Prolong the line ① up to the point where it crosses the outside air temperature indicated as red curve (e.g., -15°C) and draw a horizontal line ④ from this point to the right to the intersection of water in/out temperature curve (e.g., 90/70 °C). From this point draw a vertical line ⑤ up to the scale of heating coil capacity (13.5 kW).
- Water flow. Prolong the line ⑥ down to water flow axis at the bottom of the graphic (0.14 l/s).
- Water pressure drop. Draw the line ⑦ from the point where line ⑥ crosses the black curve to the pressure drop axis. (1.5 kPa).

NKW

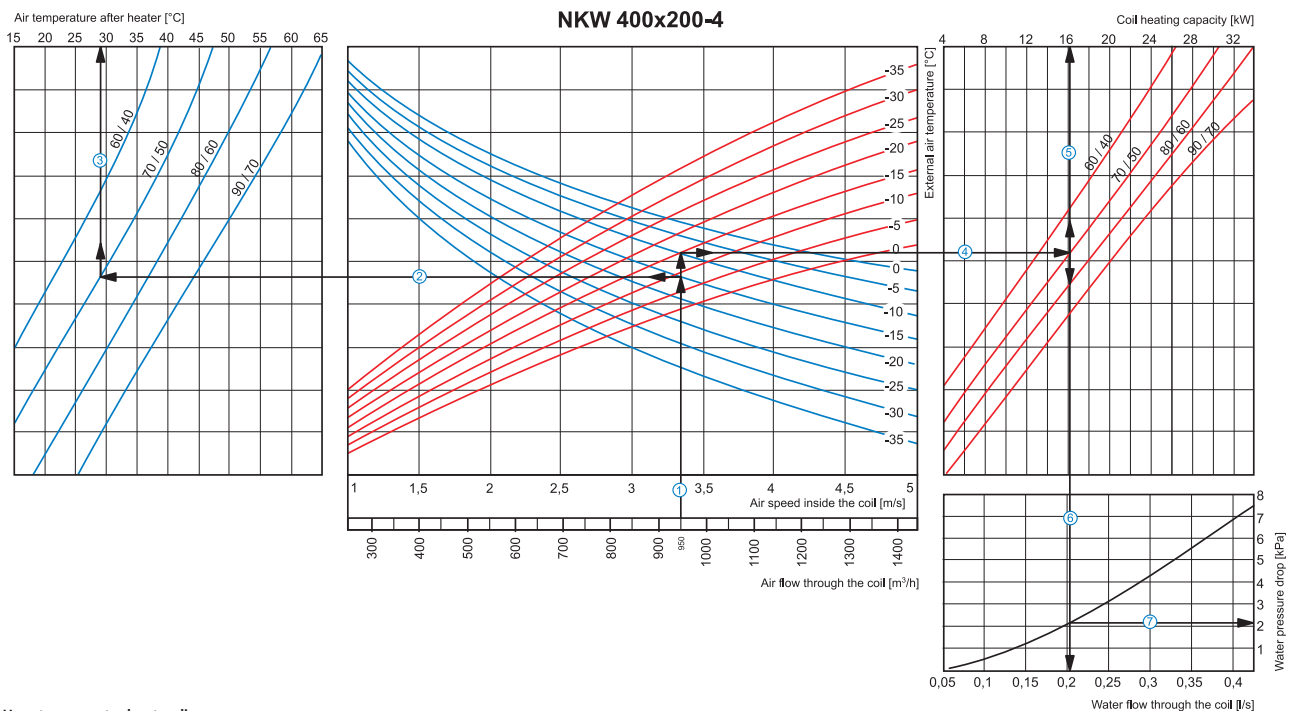

**How to use water heater diagrams**

- Air Speed. Starting from 950 m<sup>3</sup>/h on the air flow scale draw a vertical line ① till the air speed axis which makes about 3.35 m/s.
- Supply air temperature. Prolong the line ① up to the point where it crosses the outside air temperature (blue curve), e.g. -15°C; then draw a horizontal line ② from this point to the left till crossing water in/out temperature curve (70/50 °C). From this point draw a vertical line ③ to the supply air temperature axis on top of the graphic (+29°C).
- Heating coil capacity. Prolong the line ① up to the point where it crosses the outside air temperature indicated as red curve (e.g., -15°C) and draw a horizontal line ④ from this point to the right to the intersection of water in/out temperature curve (e.g., 70/50 °C). From this point draw a vertical line ⑤ up to the scale of heating coil capacity (16.0 kW).
- Water flow. Prolong the line ⑤ down to water flow axis at the bottom of the graphic ⑥ (0.2 l/s).
- Water pressure drop. Draw the line ⑦ from the point where line ⑥ crosses the black curve to the pressure drop axis. (2.1 kPa).



**NKW**

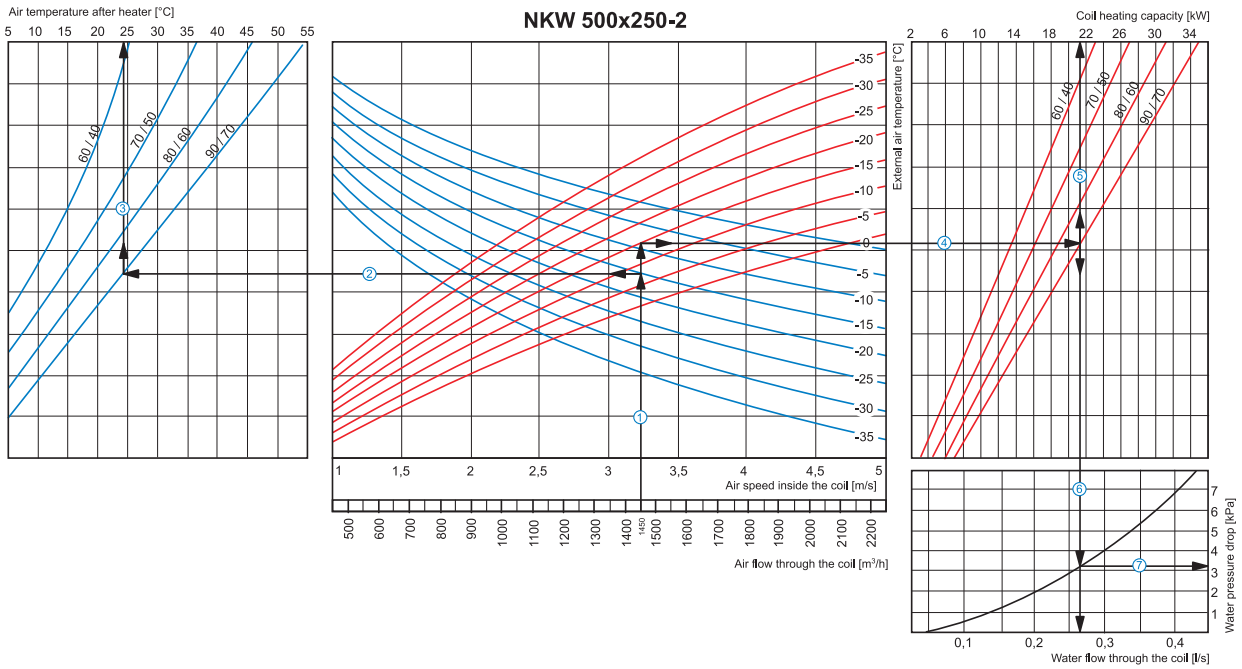

**How to use water heater diagrams**

**Air Speed.** Starting from 1450 m<sup>3</sup>/h on the air flow scale draw a vertical line ① till the air speed axis which makes about 3.2 m/s.

- **Supply air temperature.** Prolong the line ① up to the point where it crosses the outside air temperature (blue curve), e.g. -15°C; then draw a horizontal line ② from this point to the left till crossing water in/out temperature curve (90/70 °C). From this point draw a vertical line ③ to the supply air temperature axis on top of the graphic (+24°C).
- **Heating coil capacity.** Prolong the line ① up to the point where it crosses the outside air temperature indicated as red curve (e.g., -15°C) and draw a horizontal line ④ from this point to the right to the intersection of water in/out temperature curve (e.g., 90/70 °C). From this point draw a vertical line ⑤ up to the scale of heating coil capacity (21.5 kW).
- **water flow .** Prolong the line ⑤ down to water flow axis at the bottom of the graphic ⑥ (0.27 l/s).
- **Water pressure drop.** Draw the line ⑦ from the point where line ⑥ crosses the black curve to the pressure drop axis. (3.2 kPa).

**NKW**

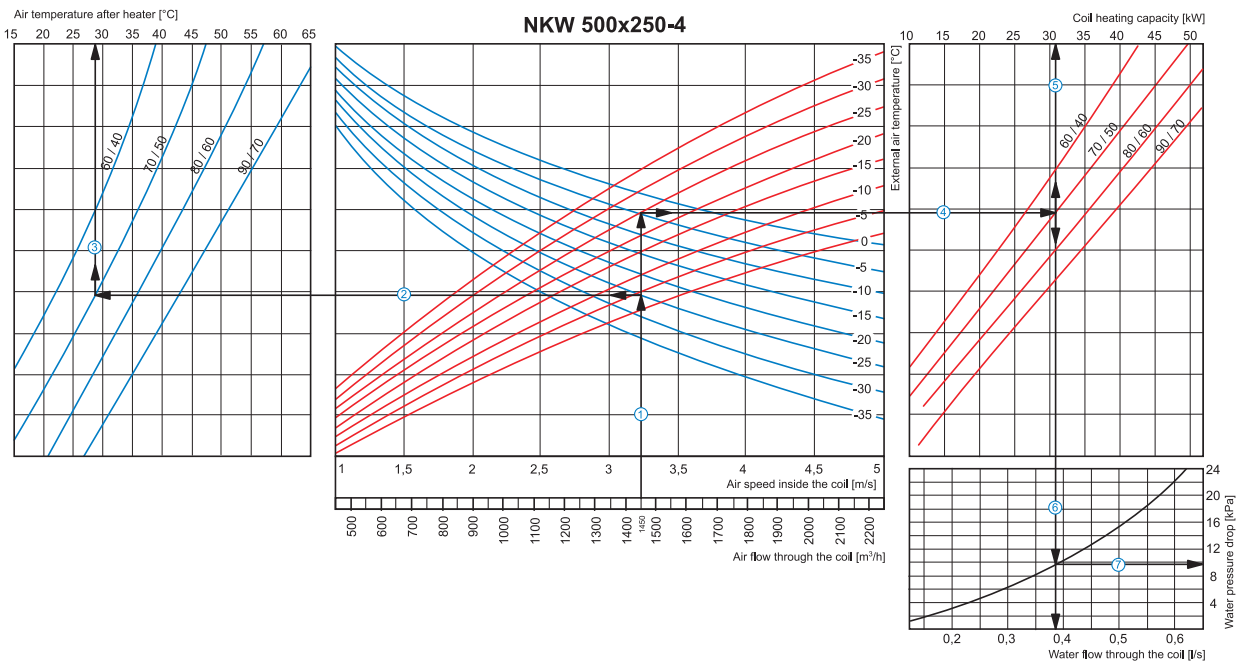

**How to use water heater diagrams**

**Air Speed.** Starting from 1450 m<sup>3</sup>/h on the air flow scale draw a vertical line ① till the air speed axis which makes about 3.2 m/s.

- **Supply air temperature.** Prolong the line ① up to the point where it crosses the outside air temperature (blue curve), e.g. -25°C; then draw a horizontal line ② from this point to the left till crossing water in/out temperature curve (70/50 °C). From this point draw a vertical line ③ to the supply air temperature axis on top of the graphic (+28°C).
- **Heating coil capacity.** Prolong the line ① up to the point where it crosses the outside air temperature indicated as red curve (e.g., -25°C) and draw a horizontal line ④ from this point to the right to the intersection of water in/out temperature curve (e.g., 70/50 °C). From this point draw a vertical line ⑤ up to the scale of heating coil capacity (31.0 kW).
- **water flow .** Prolong the line ⑤ down to water flow axis at the bottom of the graphic ⑥ (0.38 l/s).
- **Water pressure drop.** Draw the line ⑦ from the point where line ⑥ crosses the black curve to the pressure drop axis. (9.8 kPa).



NKW

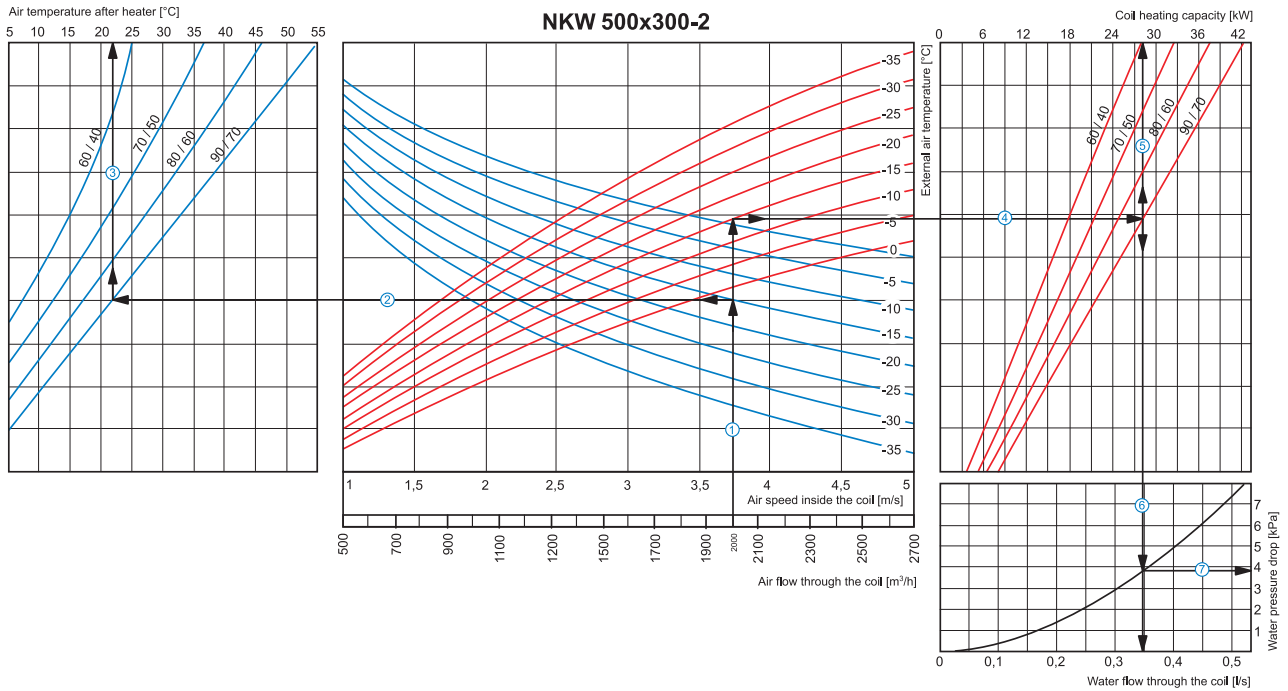

**How to use water heater diagrams**

Air Speed. Starting from 2000 m³/h on the air flow scale draw a vertical line ① till the air speed axis which makes about 3.75 m/s.

Supply air temperature. Prolong the line ① up to the point where it crosses the outside air temperature (blue curve), e.g. -15°C; then draw a horizontal line ② from this point to the left till crossing water in/out temperature curve (90/70 °C). From this point draw a vertical line ③ to the supply air temperature axis on top of the graphic (+22°C).

Heating coil capacity. Prolong the line ① up to the point where it crosses the outside air temperature indicated as red curve (e.g., -15°C) and draw a horizontal line ④ from this point to the right to the intersection of water in/out temperature curve (e.g., 90/70 °C). From this point draw a vertical line ⑤ up to the scale of heating coil capacity (28.0 kW).

Water flow. Prolong the line ⑤ down to water flow axis at the bottom of the graphic ⑥ (0.35 l/s).

Water pressure drop. Draw the line ⑦ from the point where line ⑥ crosses the black curve to the pressure drop axis. (3.8 kPa).

NKW

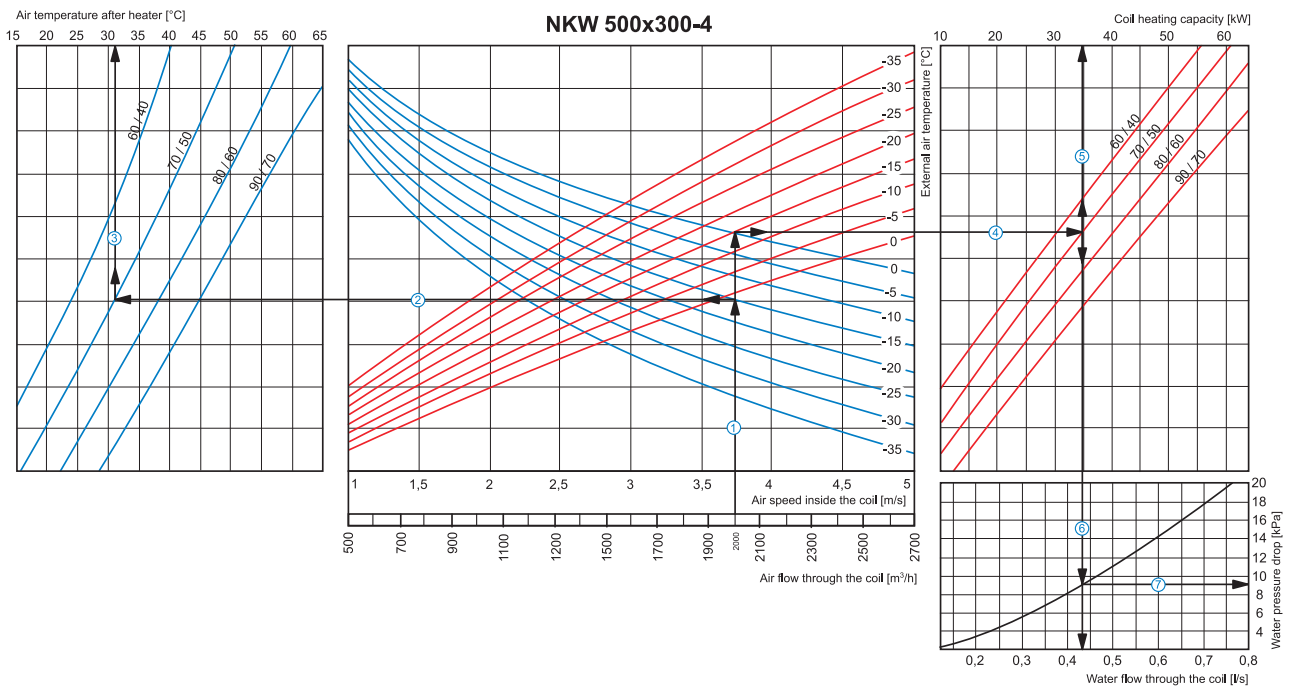

**How to use water heater diagrams**

Air Speed. Starting from 2000 m³/h on the air flow scale draw a vertical line ① till the air speed axis which makes about 3.75 m/s.

Supply air temperature. Prolong the line ① up to the point where it crosses the outside air temperature (blue curve), e.g. -15°C; then draw a horizontal line ② from this point to the left till crossing water in/out temperature curve (70/50 °C). From this point draw a vertical line ③ to the supply air temperature axis on top of the graphic (+31°C).

Heating coil capacity. Prolong the line ① up to the point where it crosses the outside air temperature indicated as red curve (e.g., -15°C) and draw a horizontal line ④ from this point to the right to the intersection of water in/out temperature curve (e.g., 70/50 °C). From this point draw a vertical line ⑤ up to the scale of heating coil capacity (35.0 kW).

Water flow. Prolong the line ⑤ down to water flow axis at the bottom of the graphic ⑥ (0.43 l/s).

Water pressure drop. Draw the line ⑦ from the point where line ⑥ crosses the black curve to the pressure drop axis. (9.0 kPa).

**NKW**

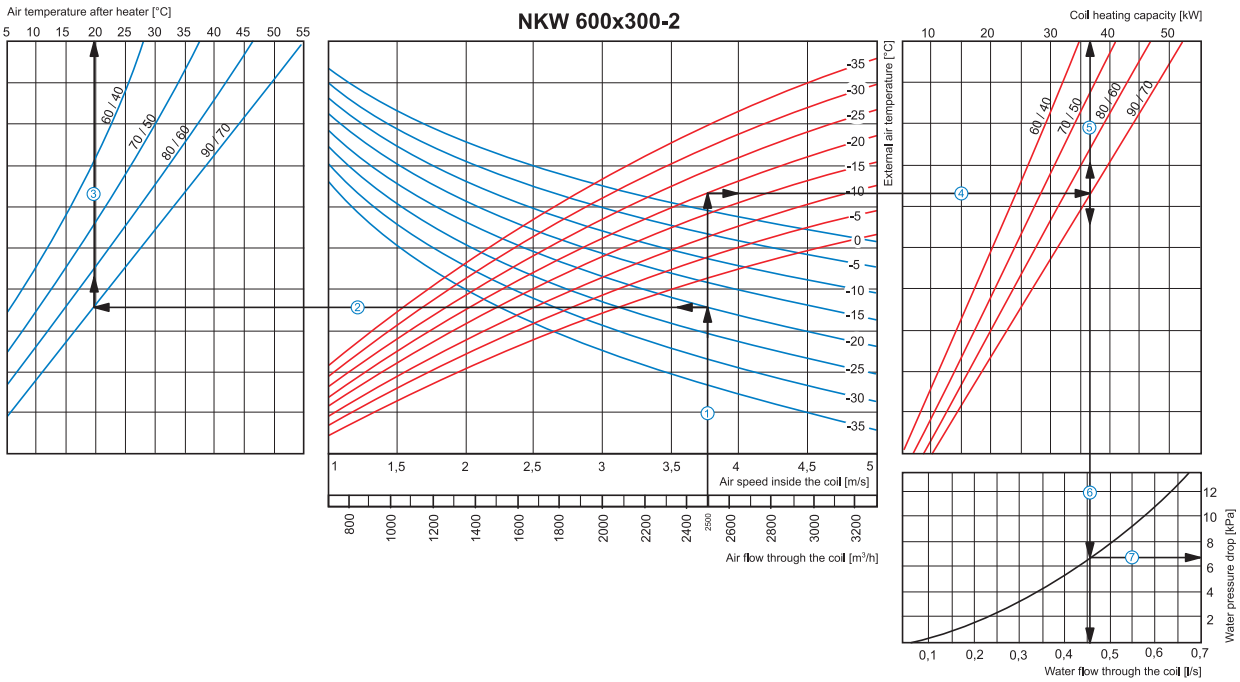

**How to use water heater diagrams**

**Air Speed.** Starting from 2000 m<sup>3</sup>/h on the air flow scale draw a vertical line ① till the air speed axis which makes about 3.75 m/s.

- **Supply air temperature.** Prolong the line ① up to the point where it crosses the outside air temperature (blue curve), e.g. -20°C; then draw a horizontal line ② from this point to the left till crossing water in/out temperature curve (90/70 °C). From this point draw a vertical line ③ to the supply air temperature axis on top of the graphic (+20°C).
- **Heating coil capacity.** Prolong the line ① up to the point where it crosses the outside air temperature indicated as red curve (e.g., -20°C) and draw a horizontal line ④ from this point to the right to the intersection of water in/out temperature curve (e.g., 90/70 °C). From this point draw a vertical line ⑤ up to the scale of heating coil capacity (37.0 kW).
- **Water flow.** Prolong the line ⑤ down to water flow axis at the bottom of the graphic ⑥ (0.46 l/s).
- **Water pressure drop.** Draw the line ⑦ from the point where line ⑥ crosses the black curve to the pressure drop axis. (6.7 kPa).

**NKW**

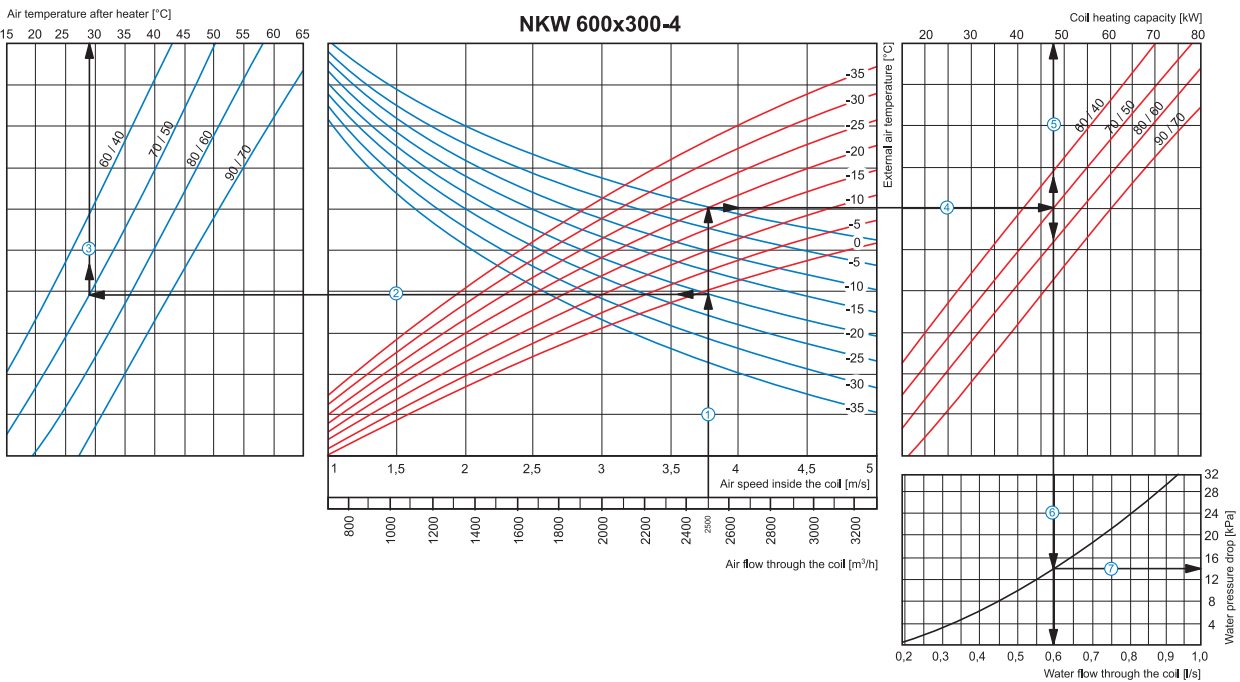

**How to use water heater diagrams**

**Air Speed.** Starting from 2500 m<sup>3</sup>/h on the air flow scale draw a vertical line ① till the air speed axis which makes about 3.75 m/s.

- **Supply air temperature.** Prolong the line ① up to the point where it crosses the outside air temperature (blue curve), e.g. -20°C; then draw a horizontal line ② from this point to the left till crossing water in/out temperature curve (70/50 °C). From this point draw a vertical line ③ to the supply air temperature axis on top of the graphic (+29°C).
- **Heating coil capacity.** Prolong the line ① up to the point where it crosses the outside air temperature indicated as red curve (e.g., -20°C) and draw a horizontal line ④ from this point to the right to the intersection of water in/out temperature curve (e.g., 70/50 °C). From this point draw a vertical line ⑤ up to the scale of heating coil capacity (48.0 kW).
- **Water flow.** Prolong the line ⑤ down to water flow axis at the bottom of the graphic ⑥ (0.6 l/s).
- **Water pressure drop.** Draw the line ⑦ from the point where line ⑥ crosses the black curve to the pressure drop axis. (14.0 kPa).

NKW

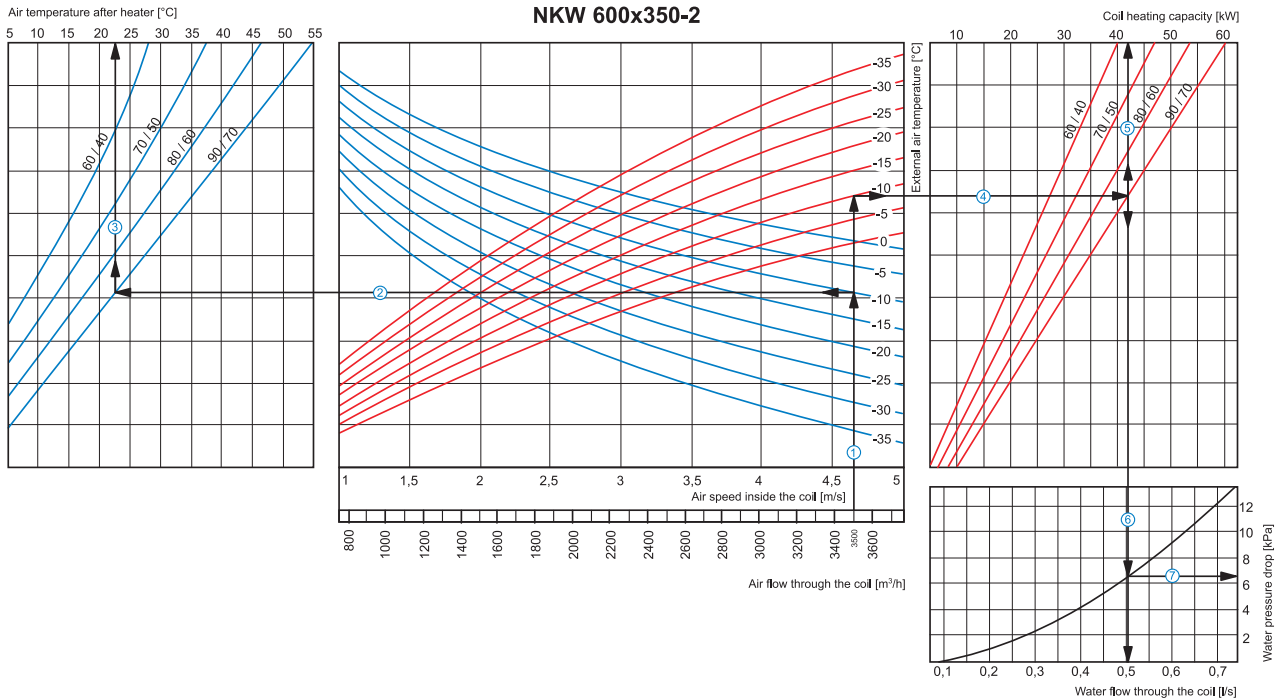

**How to use water heater diagrams**

**Air Speed.** Starting from 3500 m<sup>3</sup>/h on the air flow scale draw a vertical line ① till the air speed axis which makes about 4.65 m/s.

- **Supply air temperature.** Prolong the line ① up to the point where it crosses the outside air temperature (blue curve), e.g. -10°C, then draw a horizontal line ② from this point to the left till crossing water in/out temperature curve (90/70 °C). From this point draw a vertical line ③ to the supply air temperature axis on top of the graphic (+22.5°C).
- **Heating coil capacity.** Prolong the line ① up to the point where it crosses the outside air temperature indicated as red curve (e.g., -10°C) and draw a horizontal line ④ from this point to the right to the intersection of water in/out temperature curve (e.g., 90/70 °C). From this point draw a vertical line ⑤ up to the scale of heating coil capacity (42.0 kW).
- **water flow.** Prolong the line ⑤ down to water flow axis at the bottom of the graphic ⑥ (0.5 l/s).
- **Water pressure drop.** Draw the line ⑦ from the point where line ⑥ crosses the black curve to the pressure drop axis. (6.5 kPa).

NKW

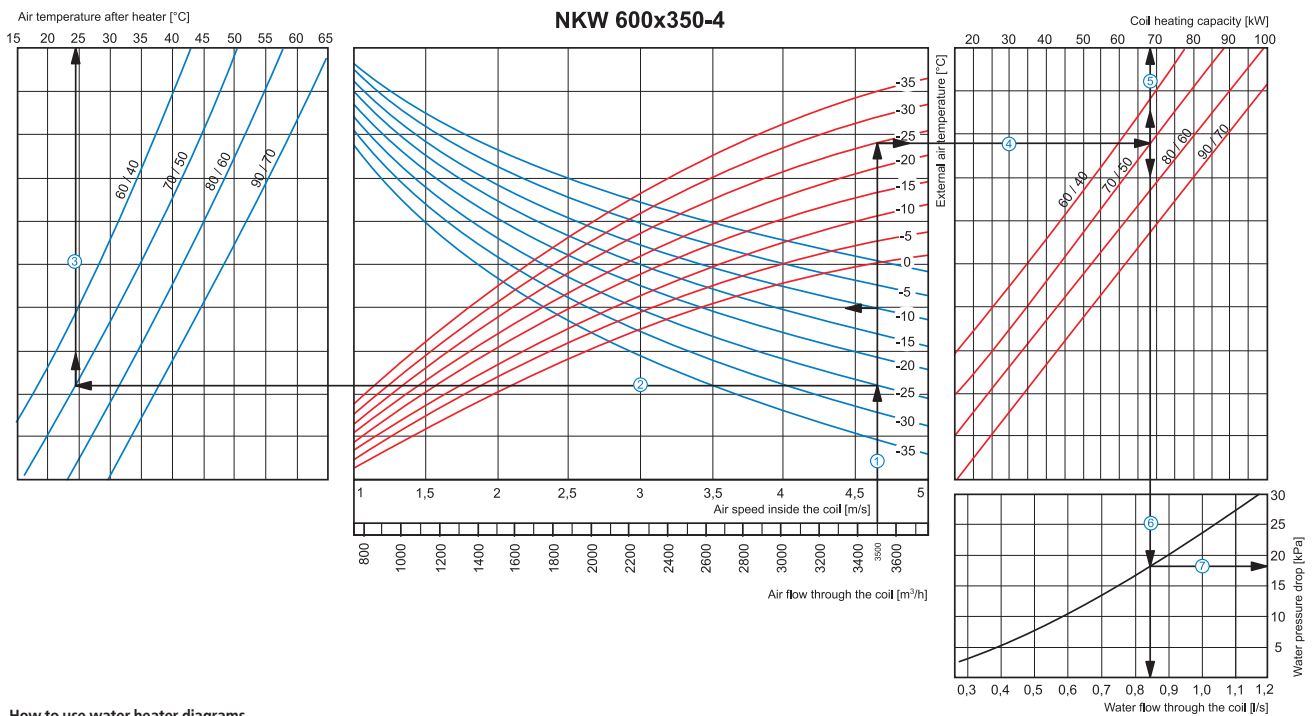

**How to use water heater diagrams**

**Air Speed.** Starting from 3500 m<sup>3</sup>/h on the air flow scale draw a vertical line ① till the air speed axis which makes about 4.65 m/s.

- **Supply air temperature.** Prolong the line ① up to the point where it crosses the outside air temperature (blue curve), e.g. -25°C, then draw a horizontal line ② from this point to the left till crossing water in/out temperature curve (70/50 °C). From this point draw a vertical line ③ to the supply air temperature axis on top of the graphic (+24°C).
- **Heating coil capacity.** Prolong the line ① up to the point where it crosses the outside air temperature indicated as red curve (e.g., -25°C) and draw a horizontal line ④ from this point to the right to the intersection of water in/out temperature curve (e.g., 70/50 °C). From this point draw a vertical line ⑤ up to the scale of heating coil capacity (68.0 kW).
- **water flow.** Prolong the line ⑤ down to water flow axis at the bottom of the graphic ⑥ (0.84 l/s).
- **Water pressure drop.** Draw the line ⑦ from the point where line ⑥ crosses the black curve to the pressure drop axis. (18.0 kPa).

**NKW**

Air temperature after heater [°C]

**NKW 700x400-2**

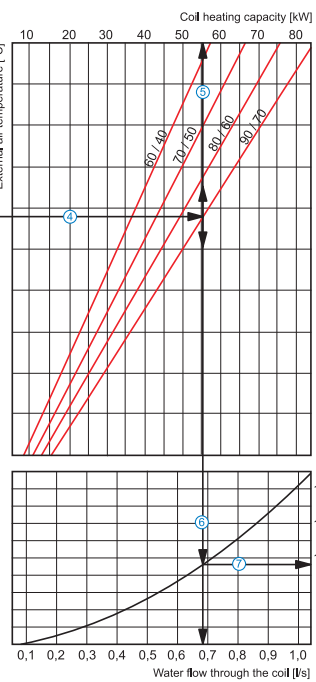
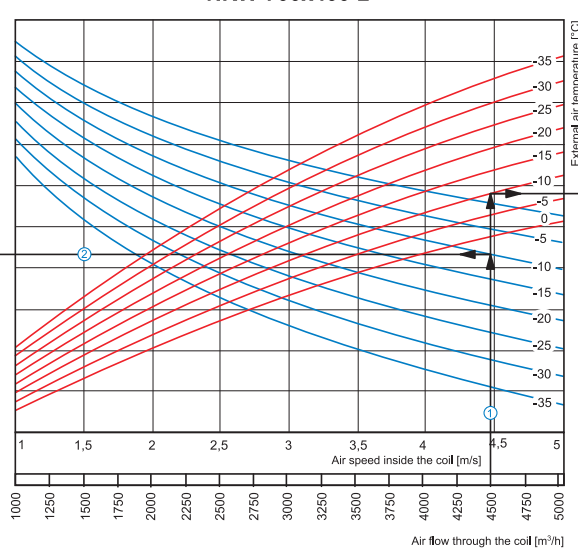
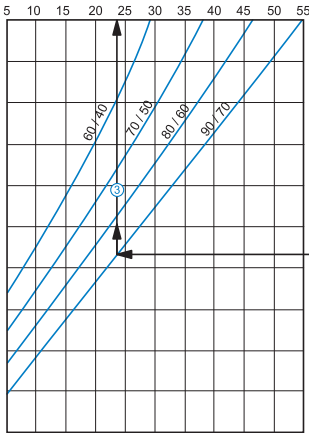

**How to use water heater diagrams**

**Air Speed.** Starting from 4500 m<sup>3</sup>/h on the air flow scale draw a vertical line ① till the air speed axis which makes about 4.45 m/s.

■ **Supply air temperature.** Prolong the line ① up to the point where it crosses the outside air temperature (blue curve), e.g. -10°C, then draw a horizontal line ② from this point to the left till crossing water in/out temperature curve (90/70 °C). From this point draw a vertical line ③ to the supply air temperature axis on top of the graphic (+24°C).

■ **Heating coil capacity.** Prolong the line ① up to the point where it crosses the outside air temperature indicated as red curve (e.g., -10°C) and draw a horizontal line ④ from this point to the right to the intersection of water in/out temperature curve (e.g., 90/70 °C). From this point draw a vertical line ⑤ up to the scale of heating coil capacity (55.0 kW).

■ **Water flow.** Prolong the line ⑤ down to water flow axis at the bottom of the graphic (⑥) (0.68 l/s).

■ **Water pressure drop.** Draw the line ⑦ from the point where line ⑥ crosses the black curve to the pressure drop axis. (9.2 kPa).

**NKW**

Air temperature after heater [°C]

**NKW 700x400-3**

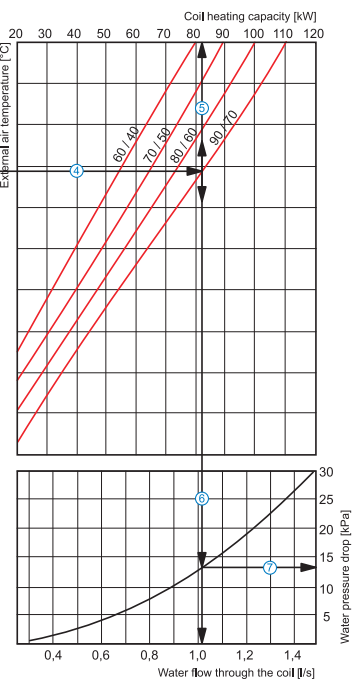
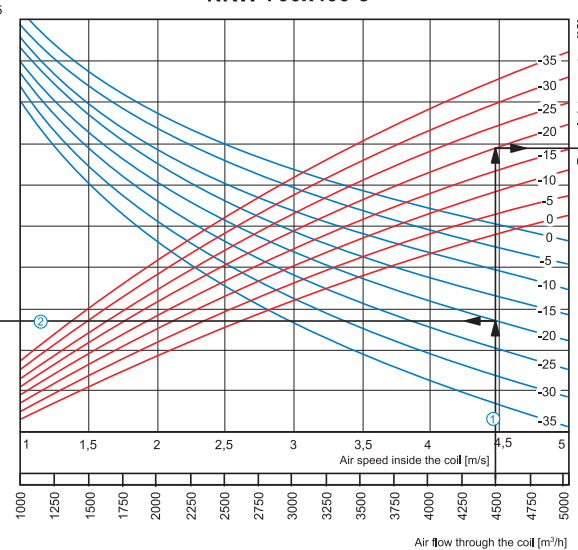
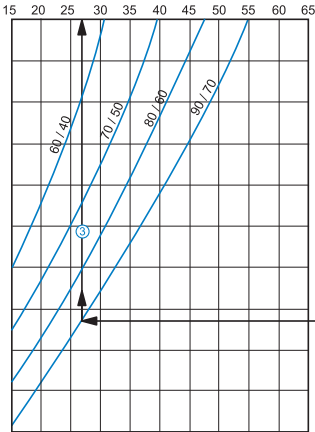

**How to use water heater diagrams**

**Air Speed.** Starting from 4500 m<sup>3</sup>/h on the air flow scale draw a vertical line ① till the air speed axis which makes about 4.45 m/s.

■ **Supply air temperature.** Prolong the line ① up to the point where it crosses the outside air temperature (blue curve), e.g. -20°C, then draw a horizontal line ② from this point to the left till crossing water in/out temperature curve (90/70 °C). From this point draw a vertical line ③ to the supply air temperature axis on top of the graphic (+27°C).

■ **Heating coil capacity.** Prolong the line ① up to the point where it crosses the outside air temperature indicated as red curve (e.g., -20°C) and draw a horizontal line ④ from this point to the right to the intersection of water in/out temperature curve (e.g., 90/70 °C). From this point draw a vertical line ⑤ up to the scale of heating coil capacity (82.0 kW).

■ **Water flow.** Prolong the line ⑤ down to water flow axis at the bottom of the graphic (⑥) (1.02 l/s).

■ **Water pressure drop.** Draw the line ⑦ from the point where line ⑥ crosses the black curve to the pressure drop axis. (13.0 kPa).

NKW

Air temperature after heater [°C]

NKW 800x500-2

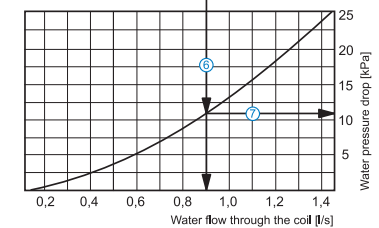
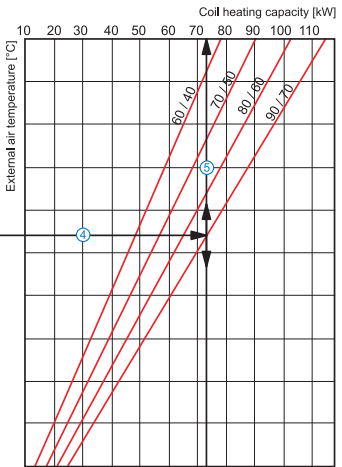
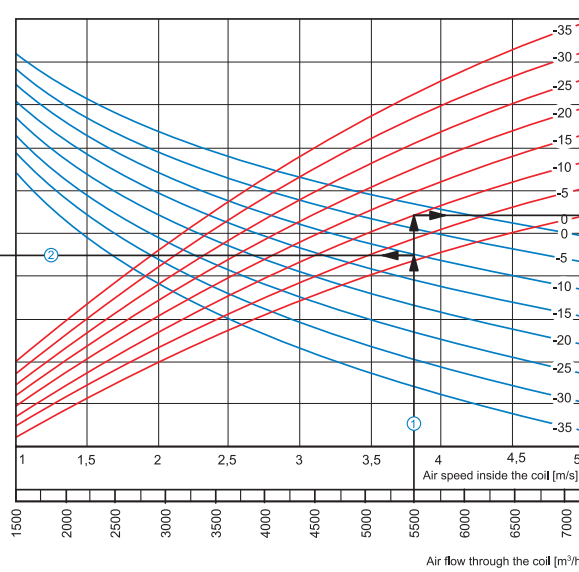
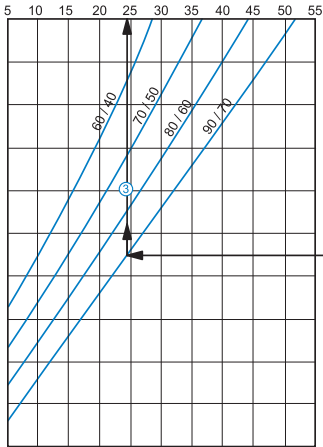

How to use water heater diagrams

Air Speed. Starting from 5500 m<sup>3</sup>/h on the air flow scale draw a vertical line ① till the air speed axis. It makes 3.8 m/s.

- Supply air temperature. Prolong the line ① up to the point where it crosses the outside air temperature (blue curve), e.g. -10°C; then draw a horizontal line ② from this point to the left till crossing water in/out temperature curve (90/70 °C). From this point draw a vertical line ③ to the supply air temperature axis on top of the graphic (+24.5°C).
- Heating coil capacity. Prolong the line ① up to the point where it crosses the outside air temperature indicated as red curve (e.g., -10°C) and draw a horizontal line ④ from this point to the right to the intersection of water in/out temperature curve (e.g., 90/70 °C). From this point draw a vertical line ⑤ up to the scale of heating coil capacity (73.0 kW).
- Water flow. Prolong the line ⑤ down to water flow axis at the bottom of the graphic ⑥ (0.9 l/s).
- Water pressure drop. Draw the line ⑦ from the point where line ⑥ crosses the black curve to the pressure drop axis. (11.0 kPa).

NKW

Air temperature after heater [°C]

NKW 800x500-3

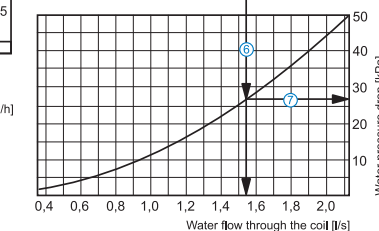
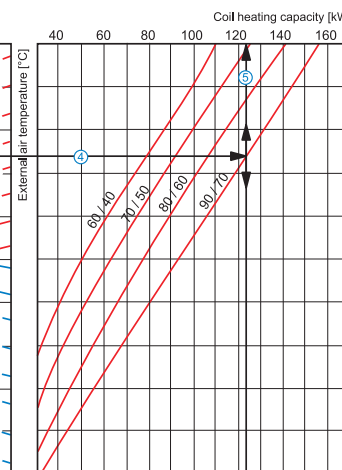
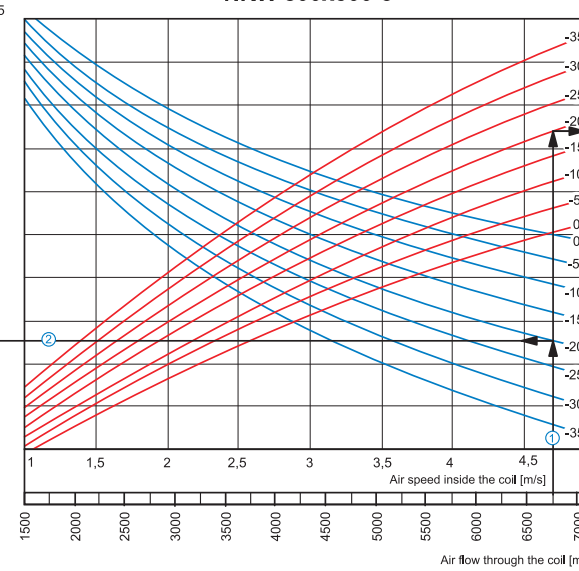
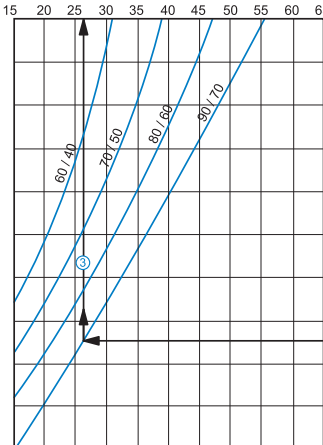

How to use water heater diagrams

Air Speed. Starting from 6750 m<sup>3</sup>/h on the air flow scale draw a vertical line ① till the air speed axis. It makes 4.7 m/s.

- Supply air temperature. Prolong the line ① up to the point where it crosses the outside air temperature (blue curve), e.g. -20°C; then draw a horizontal line ② from this point to the left till crossing water in/out temperature curve (90/70 °C). From this point draw a vertical line ③ to the supply air temperature axis on top of the graphic (+26°C).
- Heating coil capacity. Prolong the line ① up to the point where it crosses the outside air temperature indicated as red curve (e.g., -20°C) and draw a horizontal line ④ from this point to the right to the intersection of water in/out temperature curve (e.g., 90/70 °C). From this point draw a vertical line ⑤ up to the scale of heating coil capacity (123.0 kW).
- Water flow. Prolong the line ⑤ down to water flow axis at the bottom of the graphic ⑥ (1.54 l/s).
- Water pressure drop. Draw the line ⑦ from the point where line ⑥ crosses the black curve to the pressure drop axis. (27.0 kPa).



**NKW**

Air temperature after heater [°C]

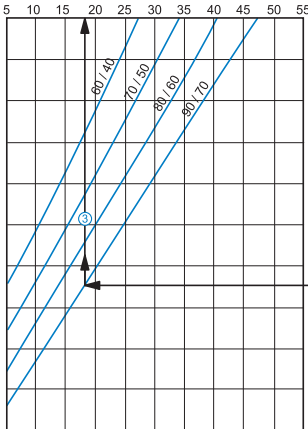

**NKW 900x500-2**

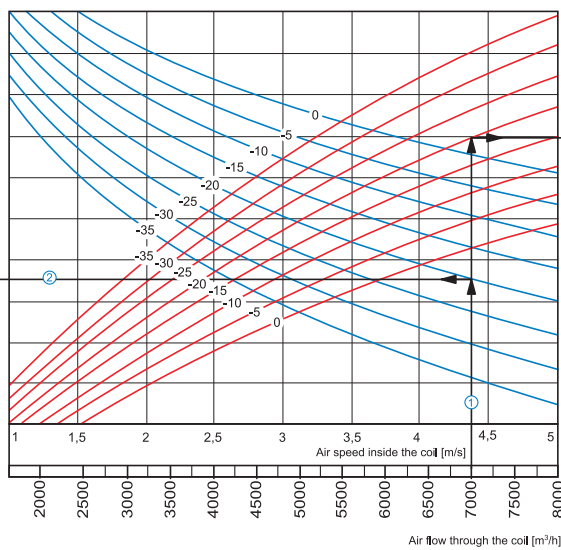

Coil heating capacity [kW]

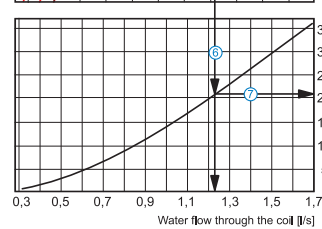
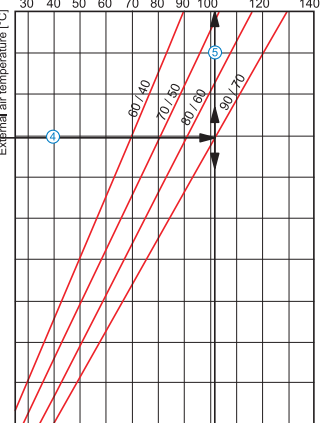

**How to use water heating coils diagrams**

**Air Speed.** Starting from 7000 m<sup>3</sup>/h on the air flow scale draw a vertical line ① till the air speed axis. It makes 4.4 m/s.

■ **Supply air temperature.** Prolong the line ① up to the point where it crosses the outside air temperature (blue curve), e.g. -20°C; then draw a horizontal line ② from this point to the left till crossing water in/out temperature curve (90/70 °C). From this point draw a vertical line ③ to the supply air temperature axis on top of the graphic (+18°C).

■ **Heating coil capacity.** Prolong the line ① up to the point where it crosses the outside air temperature indicated as red curve (e.g., -20°C) and draw a horizontal line ④ from this point to the right to the intersection of water in/out temperature curve (e.g., 90/70 °C). From this point draw a vertical line ⑤ up to the scale of heating coil capacity (102.0 kW).

■ **Water flow.** Prolong the line ⑤ down to water flow axis at the bottom of the graphic ⑥ (1.23 l/s).

■ **Water pressure drop.** Draw the line ⑦ from the point where line ⑥ crosses the black curve to the pressure drop axis. (21.0 kPa).

**NKW**

Air temperature after heater [°C]

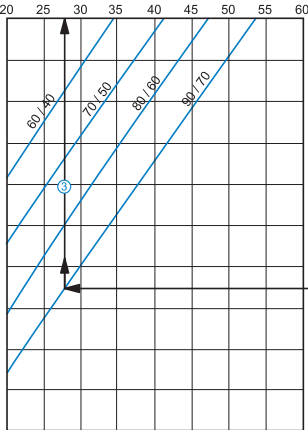

**NKW 900x500-3**

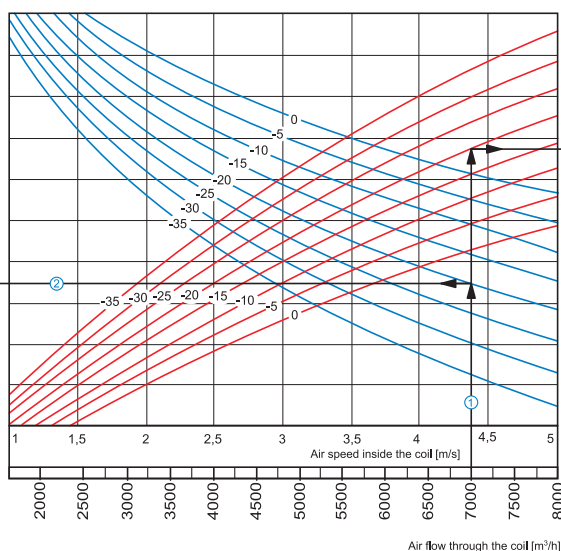

Coil heating capacity [kW]

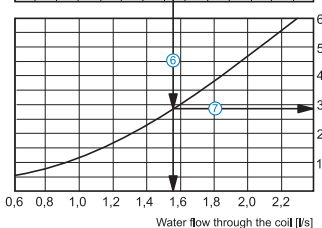
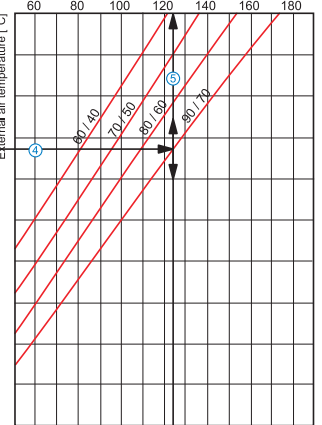

**How to use water heater diagrams**

**Air Speed.** Starting from 7000 m<sup>3</sup>/h on the air flow scale draw a vertical line ① till the air speed axis. It makes 4.4 m/s.

■ **Supply air temperature.** Prolong the line ① up to the point where it crosses the outside air temperature (blue curve), e.g. -20°C; then draw a horizontal line ② from this point to the left till crossing water in/out temperature curve (90/70 °C). From this point draw a vertical line ③ to the supply air temperature axis on top of the graphic (+28°C).

■ **Heating coil capacity.** Prolong the line ① up to the point where it crosses the outside air temperature indicated as red curve (e.g., -20°C) and draw a horizontal line ④ from this point to the right to the intersection of water in/out temperature curve (e.g., 90/70 °C). From this point draw a vertical line ⑤ up to the scale of heating coil capacity (124.0 kW).

■ **Water flow.** Prolong the line ⑤ down to water flow axis at the bottom of the graphic ⑥ (1.55 l/s).

■ **Water pressure drop.** Draw the line ⑦ from the point where line ⑥ crosses the black curve to the pressure drop axis. (28.0 kPa).



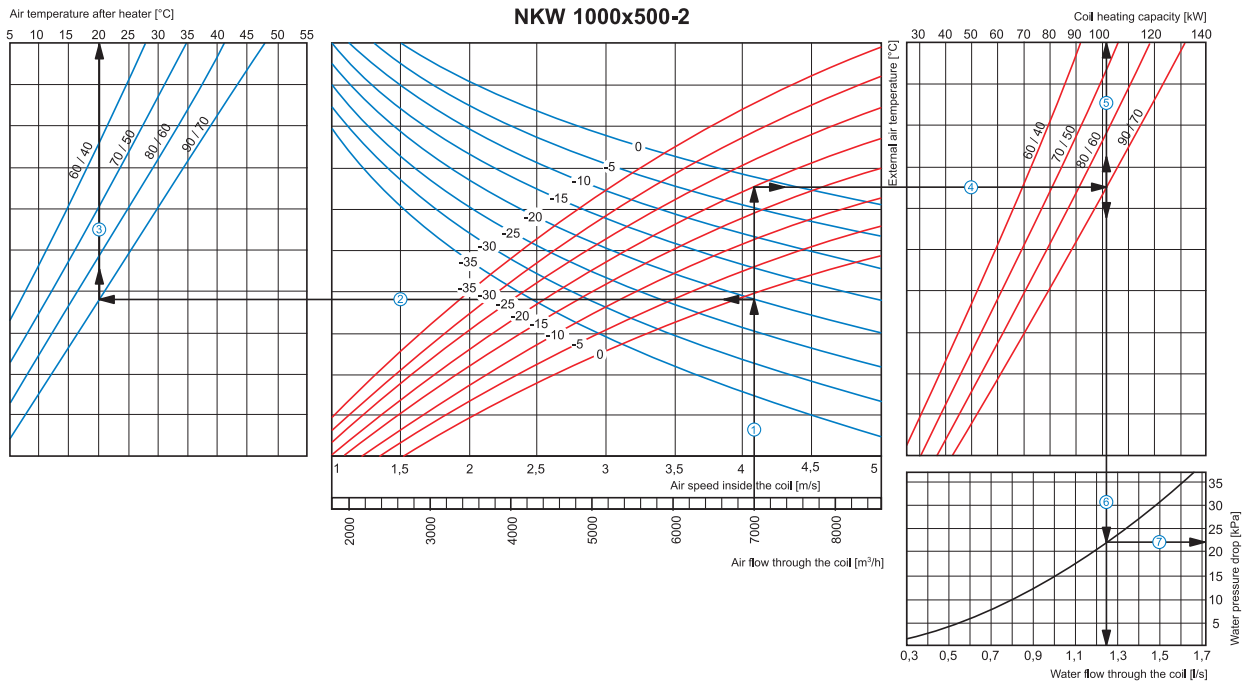

**How to use water heater diagrams**

**Air Speed.** Starting from 7000 m³/h on the air flow scale draw a vertical line ① till the air speed axis. It makes 4.1 m/s.

■ **Supply air temperature.** Prolong the line ① up to the point where it crosses the outside air temperature (blue curve), e.g. -20°C; then draw a horizontal line ② from this point to the left till crossing water in/out temperature curve (90/70 °C). From this point draw a vertical line ③ to the supply air temperature axis on top of the graphic (+20°C).

■ **Heating coil capacity.** Prolong the line ① up to the point where it crosses the outside air temperature indicated as red curve (e.g., -20°C) and draw a horizontal line ④ from this point to the right to the intersection of water in/out temperature curve (e.g., 90/70 °C). From this point draw a vertical line ⑤ up to the scale of heating coil capacity (101.0 kW).

■ **Water flow.** Prolong the line ⑤ down to water flow axis at the bottom of the graphic ⑥ (1.25 l/s).

■ **Water pressure drop.** Draw the line ⑦ from the point where line ⑥ crosses the black curve to the pressure drop axis. (22.0 kPa).

**NKW**

**NKW 1000x500-3**

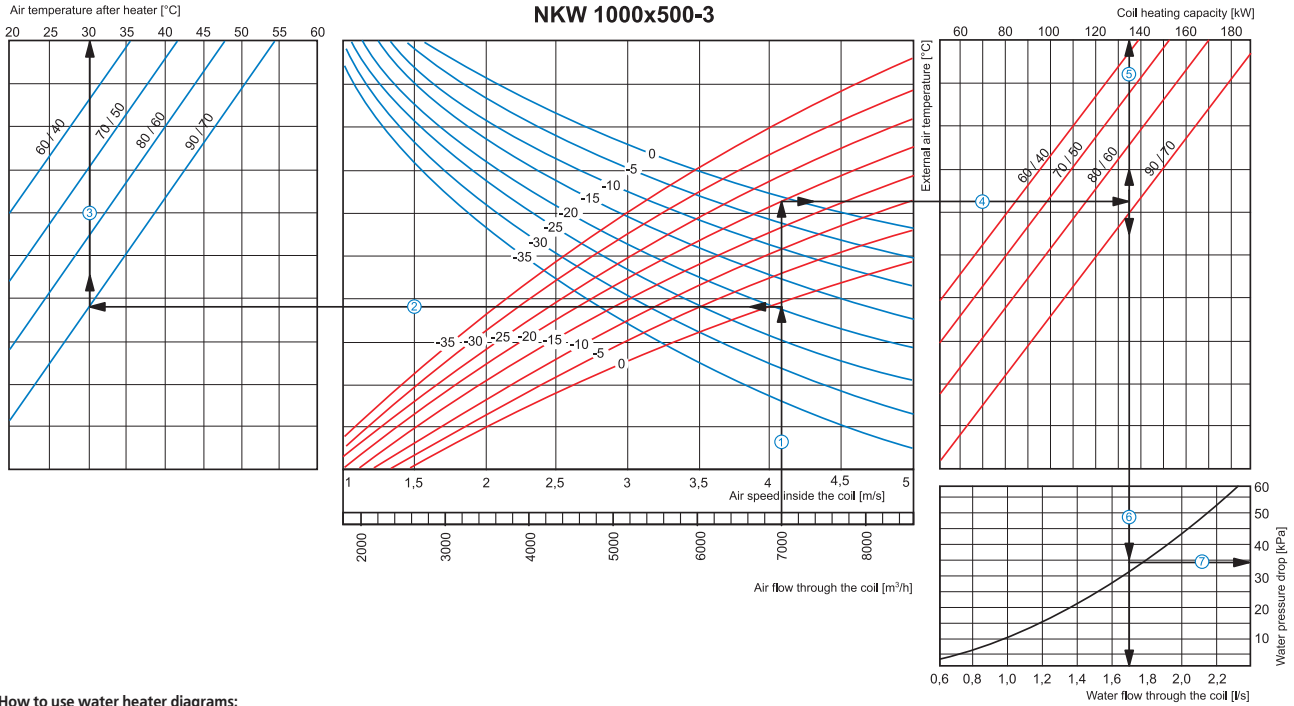

**How to use water heater diagrams:**

**Air Speed.** Starting from 7000 m<sup>3</sup>/h on the air flow scale draw a vertical line ① till the air speed axis. It makes 4.1 m/s.

■ **Supply air temperature.** Prolong the line ① up to the point where it crosses the outside air temperature (blue curve), e.g. -20°C; then draw a horizontal line ② from this point to the left till crossing water in/out temperature curve (90/70 °C). From this point draw a vertical line ③ to the supply air temperature axis on top of the graphic (+30°C).

■ **Heating coil capacity.** Prolong the line ① up to the point where it crosses the outside air temperature indicated as red curve (e.g., -20°C) and draw a horizontal line ④ from this point to the right to the intersection of water in/out temperature curve (e.g., 90/70 °C). From this point draw a vertical line ⑤ up to the scale of heating coil capacity (135.0 kW).

■ **Water flow.** Prolong the line ⑤ down to water flow axis at the bottom of the graphic ⑥ (1.7 l/s).

■ **Water pressure drop.** Draw the line ⑦ from the point where line ⑥ crosses the black curve to the pressure drop axis. (34.0 kPa).

Series  
**USWK**



■ **Applications**

Mixing sets USWK are designed for water circulation and water/water mixture temperature regulation in heat exchangers of ventilation systems.

■ **Design and operation description**

USWK design is shown at fig.1. On customer's demand both right-side and left-side applications are available. The unit piping consists of the metal elements with the heat resistance up to +150 °C. The circulation pump 1 provides the continuous required water flow rate while the supplied water temperature to the heat exchanger is regulated by means mixing of the water supplied from the network together with the heat exchanger return water in the flow circuit. Quantity of return water supplied through the bridge 4 is controlled by means of three-way valve 3 with actuator 2. The control signal of the actuator 2 depends on the supply air set temperature at water coil outlet.

■ **USWK installation and maintenance**

The electrical connection shall be performed by the

professionals only. USWK operation beyond the temperature range as well as operation in aggressive and explosion hazard environment is not allowed. Before connecting the unit to the network make sure of no visible damages.

Check the following conditions before installation:

- horizontal motor shaft direction;
- no mechanical load transfer from the connected pipelines to USWK unit;
- disabling any incidental contact of power supply wires with the rotating USWK parts.

■ **Connecting USWK to the water main**

Water supply or discharge from USWK is performed either at direct connection to the fixed water main or by means of flexible metal and rubber hoses thread-connected to and exhaust branch pipes. The connection to the water main shall be performed in such a way as to exclude any loads resulting in mechanical or airtight damages of USWK unit. The pipelines shall be connected in such a way as to ensure their easy and quick disconnection.

■ **Electrical connection**

All the electrical connections shall be performed by the professionals only. The circulation pump shall be earthed before connection. Avoid any contact of the power cord with the pipeline or the pump.

■ **USWK operating conditions**

Admissible operating conditions for the mixing sets are determined by their completement. However the following values shall be observed:

- ambient temperature, °C .....5-40
- maximum inlet water temperature, °C.....110-120
- maximum operating pressure, bar.....10

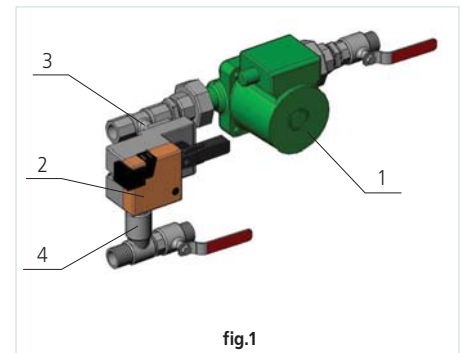

**Designation key:**

Series	Connecting diameter, mm	Transmission factor, Kvs
USWK	3/4"; 1"; 1 1/4"; 1 1/2"; 2"	4; 6; 10; 16; 25

**Technical data:**

Type US	USWK-3/4-4	USWK-1-6	USWK-1 1/4-10	USWK-1 1/2-16	USWK-2-25
Water flow rate, [m³/h]	up to 4	up to 6	up to 10	up to 16	up to 25
Head, mwc	up to 6	up to 6	up to 6	up to 11	up to 11
Kvs*	4	6,3	10	16	25
Pressure, bar	10	10	10	10	10
Connecting diameter, [mm]	3/4"	1"	1 1/4"	1 1/2"	2"
Operating temperature, [°C]	-10...+110	-10...+110	-10...+110	-10...+120	-10...+120

**Overall dimensions:**

Type	Dimensions [mm]				Mass [kg]
	B	H	H1	L	
USWK-3/4-4	150	290	180	460	4,1
USWK-1-6	175	320	210	490	6,8
USWK-1 1/4-10	175	355	240	500	7,4
USWK-1 1/2-16	266	420	255	610	23,0
USWK-2-25	312	474	290	660	31,0

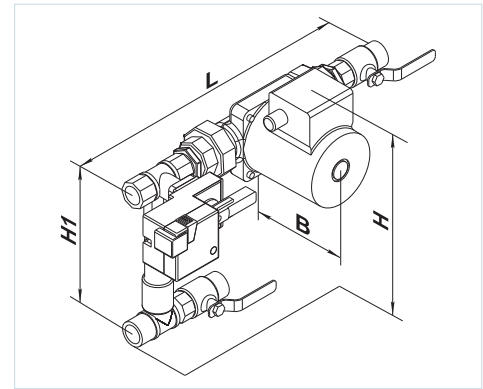

\* transmission factor  $K_{vs} = \frac{V_{100}}{\sqrt{\frac{\Delta p_{v,100}}{100}}}$ , where

$\Delta p_{v,100}$  – pressure loss at fully open valve;

$V_{100}$  – rated flow rate at  $\Delta p_{v,100}$ .

Recommended connecting diagram to the centralized waterworks

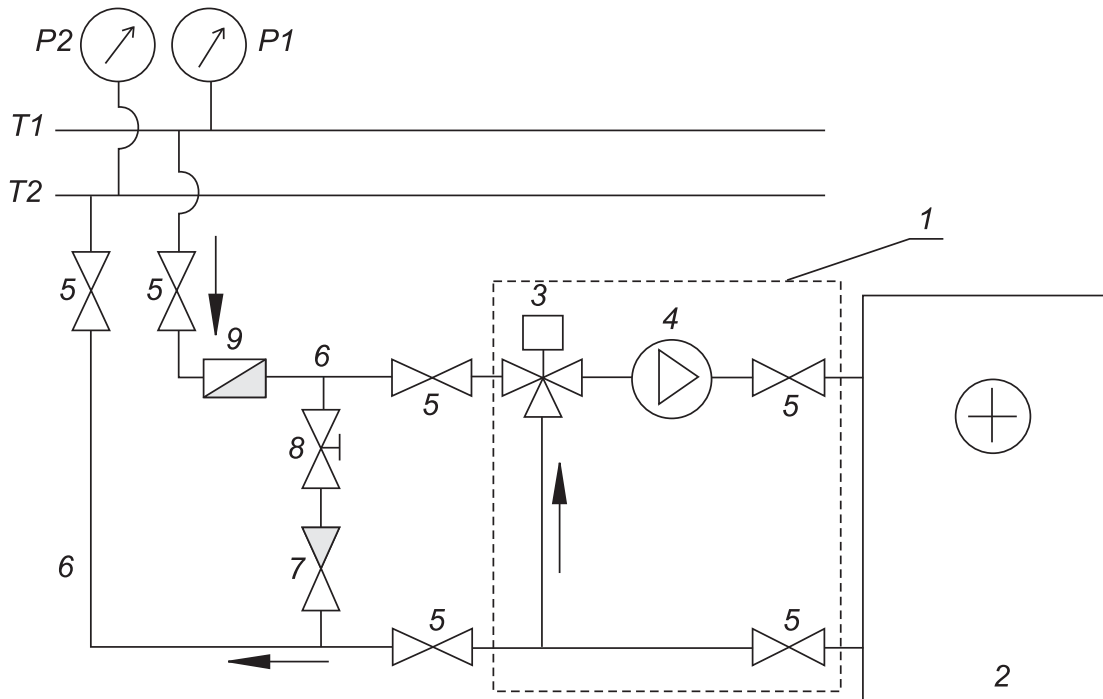

T1 and T2 - supply and return pipeline of the heating network;  
 P1 and P2 - liquid manometers in the heating network;  
 1 - USWK (mixing set);

2 - Water heating coils;  
 3 - Electric-driven three-way valve;  
 4 - Circulation pump;  
 5 - Shutoff valve;  
 6 - Supply and return pipelines from heating

networks to the heater;  
 7 - non-return valve;  
 8 - balancing valve;  
 9 - Coarse filter.

Series  
**OKW**



■ **Applications**

Duct water coil air coolers are designed for cooling of supply air in rectangular ventilation systems and can be applied in supply or supply and exhaust ventilation systems.

■ **Design**

The cooler casing is made of galvanized sheet steel, the manifold is made of copper tubes and the heat exchange surface is made of aluminium plates. The cooling coils are available in 3 rows modification and designed for the maximum operating pressure

1,5 MPa (15 bar). The cooling coils are equipped with the drain pan for condensate collecting and draining.

■ **Mounting**

▶ Mounting is effected by means of flange connection. The water cooling coils can be installed only horizontally to enable the unit deaeration and condensate draining.

▶ The installation shall be performed in such a way as to enable the uniform air distribution along the entire cross section.

▶ The air filter shall be installed at the cooler inlet to protect the cooler against dirt and dusting.

▶ The cooler can be installed both at the fan inlet or outlet. If the cooling coils are located at the fan outlet the air duct between the cooler and the fan shall have the length 1 to 1.5 m to ensure the air flow stabilization.

▶ The cooling coils shall be connected on the counterflow basis to provide the maximum cooling capacity. All the nomographic charts in the catalogue are valid for such connection.

▶ If water serves as a cooling agent, the coolers are suitable for indoor installation only in the premises with the indoor temperature not below 0 °C. For outdoor installation use an antifreeze mixture,

i.e. ethylene glycol solution.

▶ The droplet separator which is ordered separately can be installed at the cooler outlet if the air speed exceeds 2.5 m/s. That prevents the condensate drop penetration into the air duct system.

▶ Condensate drain from the cooler shall be performed through the U-trap. The U-trap height depends on the total pressure in the fan and can be calculated using the figures and the table below.

H [mm]	K [mm]	P [Pa]
100	55	600
200	105	1100
260	140	1400

H – U-trap height  
K – drain height  
P – total pressure in the fan

▶ To ensure the correct and safe cooler operation use the automation system providing the complex control and automatic regulation of the cooling capacity and air cooling temperature.

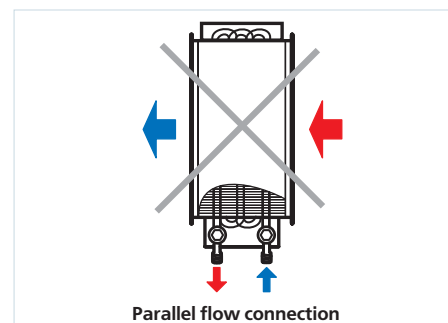
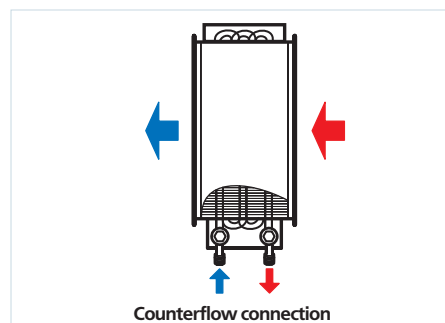

**Overall dimensions:**

Type	Dimensions [mm]												
	B	B1	B2	B3	H	H1	H2	H3	H4	L	L1	L2	K
OKW 400x200-3	400	420	438	528	200	220	238	70	273	395	176	43	G 3/4"
OKW 500x250-3	500	520	538	628	250	270	288	120	323	395	176	43	G 3/4"
OKW 500x300-3	500	520	538	628	300	320	338	175	373	395	176	43	G 3/4"
OKW 600x300-3	600	620	638	728	300	320	338	170	373	395	176	43	G 3/4"
OKW 600x350-3	600	620	638	728	350	370	388	220	423	395	176	43	G 3/4"
OKW 700x400-3	700	720	738	828	400	420	438	250	473	395	170	55	G 3/4"
OKW 800x500-3	800	820	838	928	500	520	538	340	573	395	170	55	G 3/4"
OKW 900x500-3	900	920	938	1028	500	520	538	350	573	395	170	55	G 1"
OKW 1000x500-3	1000	1020	1038	1128	500	520	538	350	573	395	170	55	G 1"

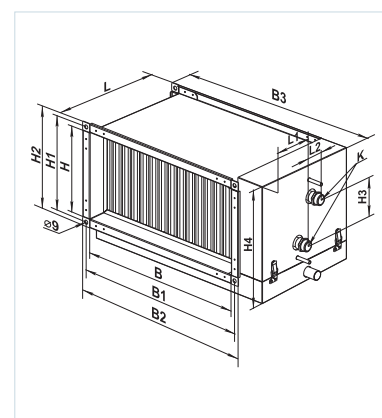

**Designation key:**

Series	Flange designation (WxH) [mm]	Number of cooling coils
OKW	400x200; 500x250; 500x300; 600x300; 600x350; 700x400; 800x500; 900x500; 1000x500	3

**Accessories**



page 280

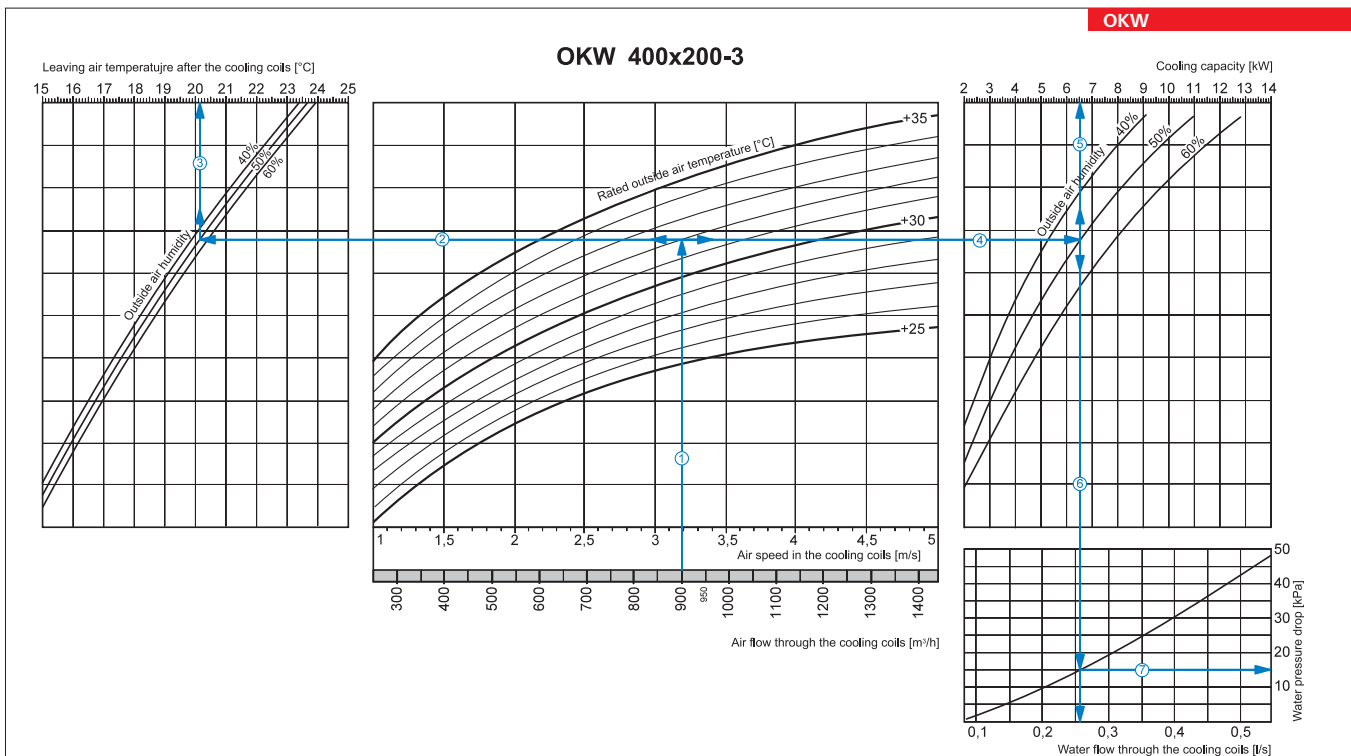
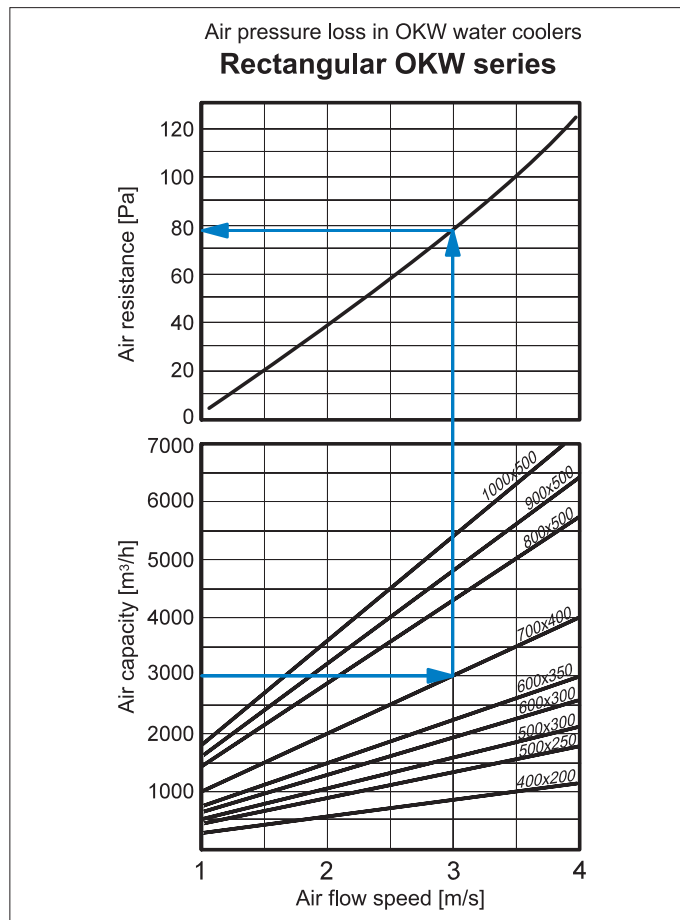

**How to use water cooler diagrams**

- Air Speed. Starting from 900 m<sup>3</sup>/h on the air flow scale draw a vertical line ① till the air speed axis. It makes 3.2 m/s.
- Supply air temperature. prolong the line ① up to the point where it crosses the outside air temperature (e.g. +32°C); then draw a horizontal line ② from this point to the left till crossing the outside air humidity (e.g. 50%). From this point draw a vertical line ③ to the supply air temperature at cooler outlet axis on top of the graphic (+20.1°C).
- Cooling capacity. Prolong the line ① up to the point where it crosses the outside air temperature (e.g. +32°C) and draw a horizontal line ④ from this point to the right until it crosses the outside air humidity curve (e.g., 50%), from here draw a vertical line ⑤ up to the scale representing the cooler capacity (6.5 kW).
- Water flow. Prolong the line ⑤ down to water flow axis at the bottom of the graphic ⑥ (0.26 l/s).
- Water pressure drop. Draw the line ⑦ from the point where the line ⑥ crosses the black curve to the pressure drop axis. (15.0 kPa).

OKW WATER COOLER



OKW

OKW 500x250-3

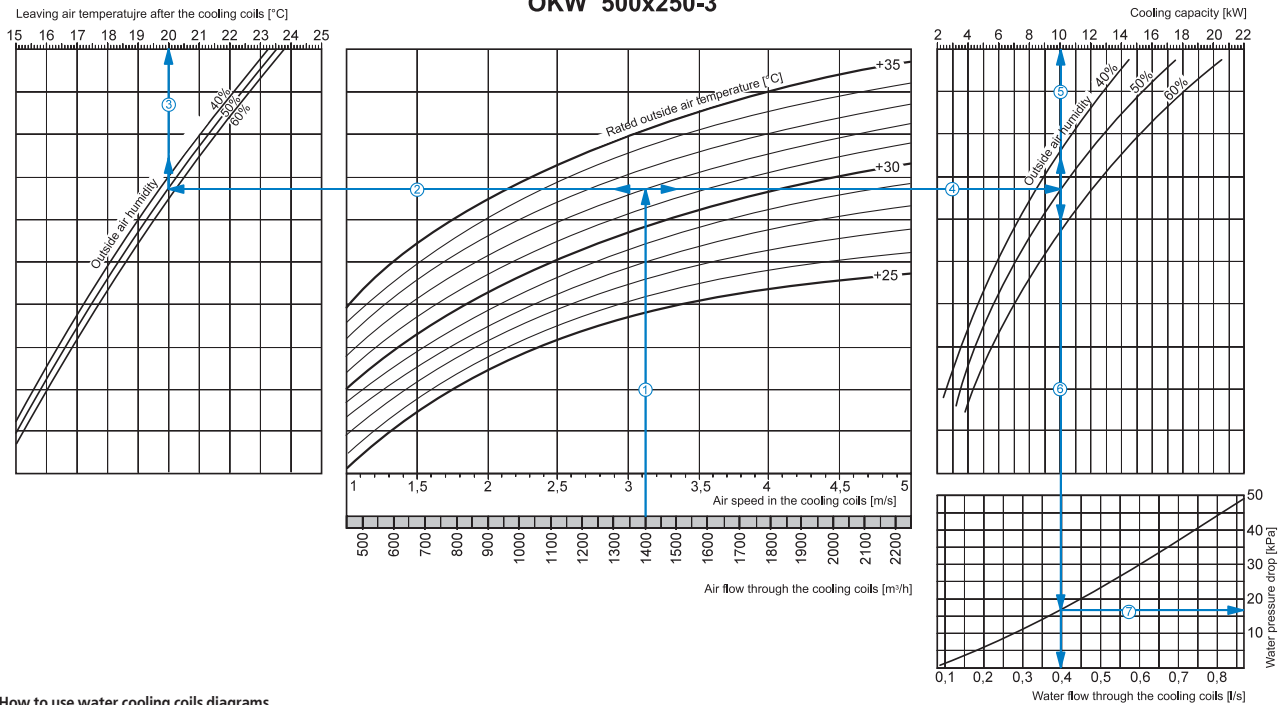

How to use water cooling coils diagrams

- Air Speed. Starting from 1400 m<sup>3</sup>/h on the air flow scale draw a vertical line ① till the air speed axis. It makes 3.1 m/s.
- Supply air temperature. prolong the line ① up to the point where it crosses the outside air temperature (e.g. +32°C); then draw a horizontal line ② from this point to the left till crossing the outside air humidity (e.g. 50%). From this point draw a vertical line ③ to the supply air temperature at cooler outlet axis on top of the graphic (+20°C).
- Cooling capacity. Prolong the line ① up to the point where it crosses the outside air temperature (e.g. +32°C) and draw a horizontal line ④ from this point to the right until it crosses the outside air humidity curve (e.g., 50%), from here draw a vertical line ⑤ up to the scale representing the cooling capacity (10.0 kW).
- Water flow. Prolong the line ⑤ down to water flow axis at the bottom of the graphic ⑥ (0.4 l/s).
- Water pressure drop. Draw the line ⑦ from the point where the line ⑥ crosses the black curve to the pressure drop axis. (17.0 kPa).

OKW

OKW 500x300-3

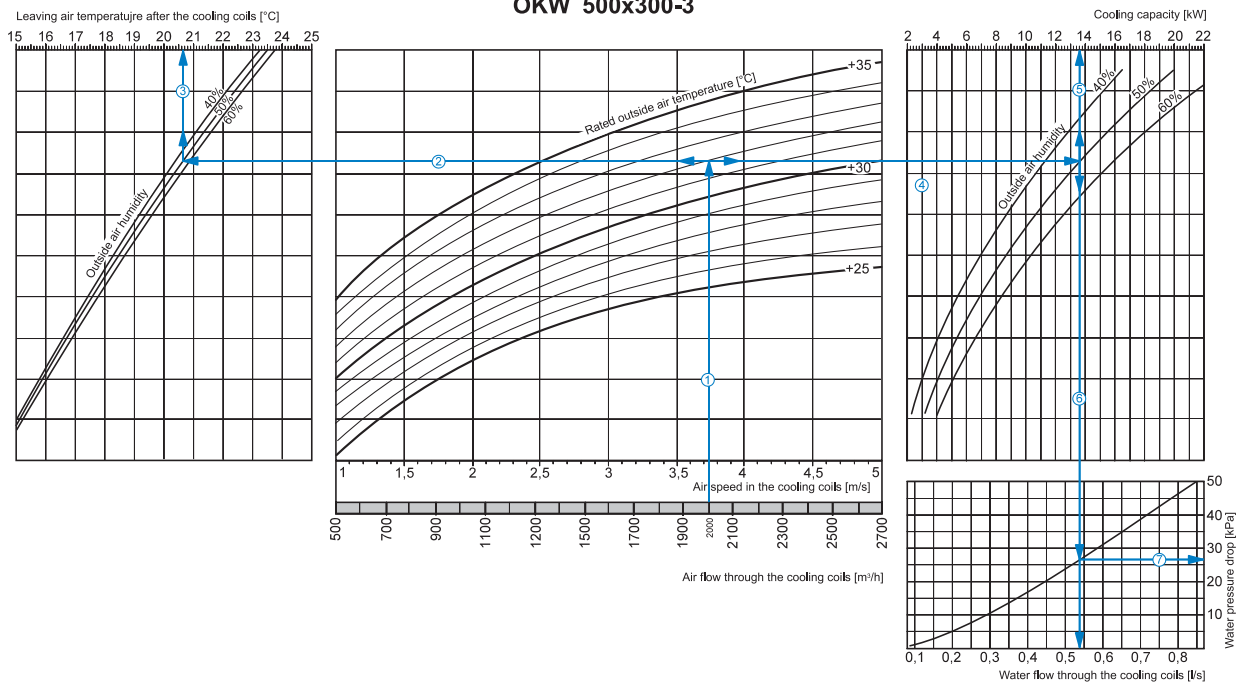

How to use water cooler diagrams

- Air Speed. Starting from 2000 m<sup>3</sup>/h on the air flow scale draw a vertical line ① till the air speed axis. It makes 3.75 m/s.
- Supply air temperature. prolong the line ① up to the point where it crosses the outside air temperature (e.g. +32°C); then draw a horizontal line ② from this point to the left till crossing the outside air humidity (e.g. 50%). From this point draw a vertical line ③ to the supply air temperature at cooler outlet axis on top of the graphic (+20.6°C).
- Cooling capacity. Prolong the line ① up to the point where it crosses the outside air temperature (e.g. +32°C) and draw a horizontal line ④ from this point to the right until it crosses the outside air humidity curve (e.g., 50%), from here draw a vertical line ⑤ up to the scale representing the cooling capacity (13.6 kW).
- Water flow. Prolong the line ⑤ down to water flow axis at the bottom of the graphic ⑥ (0.54 l/s).
- Water pressure drop. Draw the line ⑦ from the point where the line ⑥ crosses the black curve to the pressure drop axis. (27.0 kPa).

OKW

### OKW 600x300-3

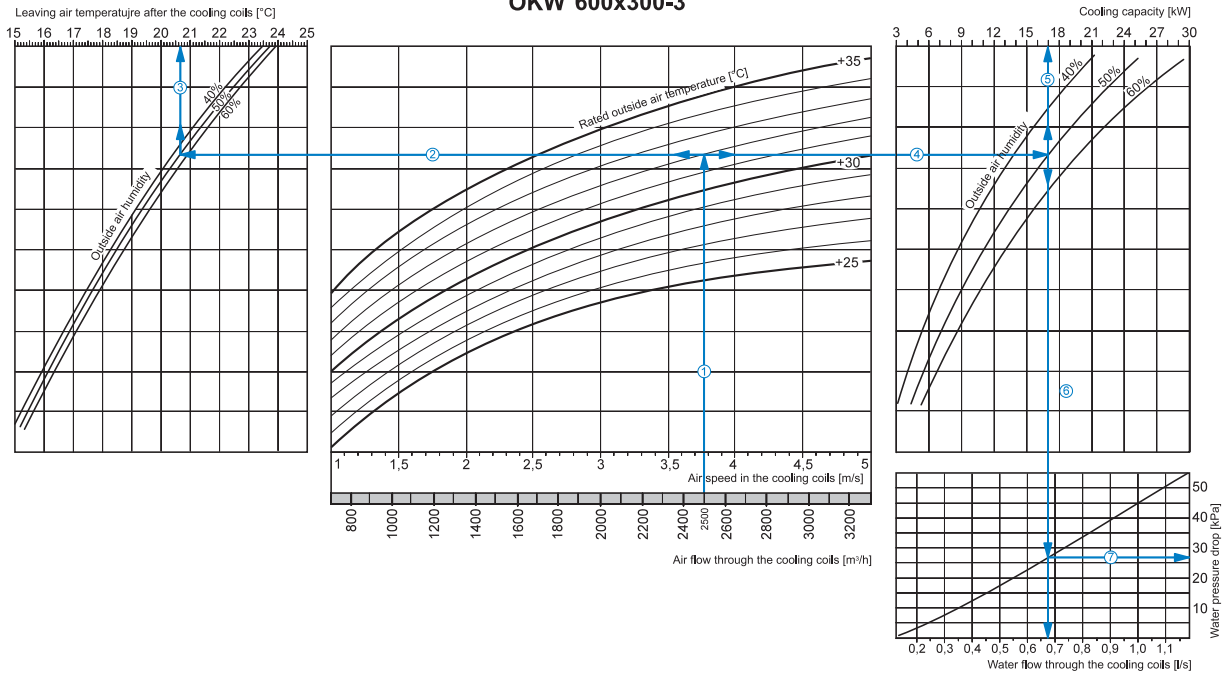

#### How to use water cooler diagrams

Air Speed. Starting from 2500 m<sup>3</sup>/h on the air flow scale draw a vertical line ① till the air speed axis. It makes 3.75 m/s.

- Supply air temperature. prolong the line ① up to the point where it crosses the outside air temperature (e.g. +32°C); then draw a horizontal line ② from this point to the left till crossing the outside air humidity (e.g. 50%). From this point draw a vertical line ③ to the supply air temperature at cooler outlet axis on top of the graphic (+20.7°C).
- Cooling capacity. Prolong the line ① up to the point where it crosses the outside air temperature (e.g. +32°C) and draw a horizontal line ④ from this point to the right until it crosses the outside air humidity curve (e.g., 50%), from here draw a vertical line ⑤ up to the scale representing the cooling capacity (17.0 kW).
- Water flow. Prolong the line ⑤ down to water flow axis at the bottom of the graphic ⑥ (0.68 l/s).
- Water pressure drop. Draw the line ⑦ from the point where the line ⑥ crosses the black curve to the pressure drop axis. (27.0 kPa).

OKW

### OKW 600x350-3

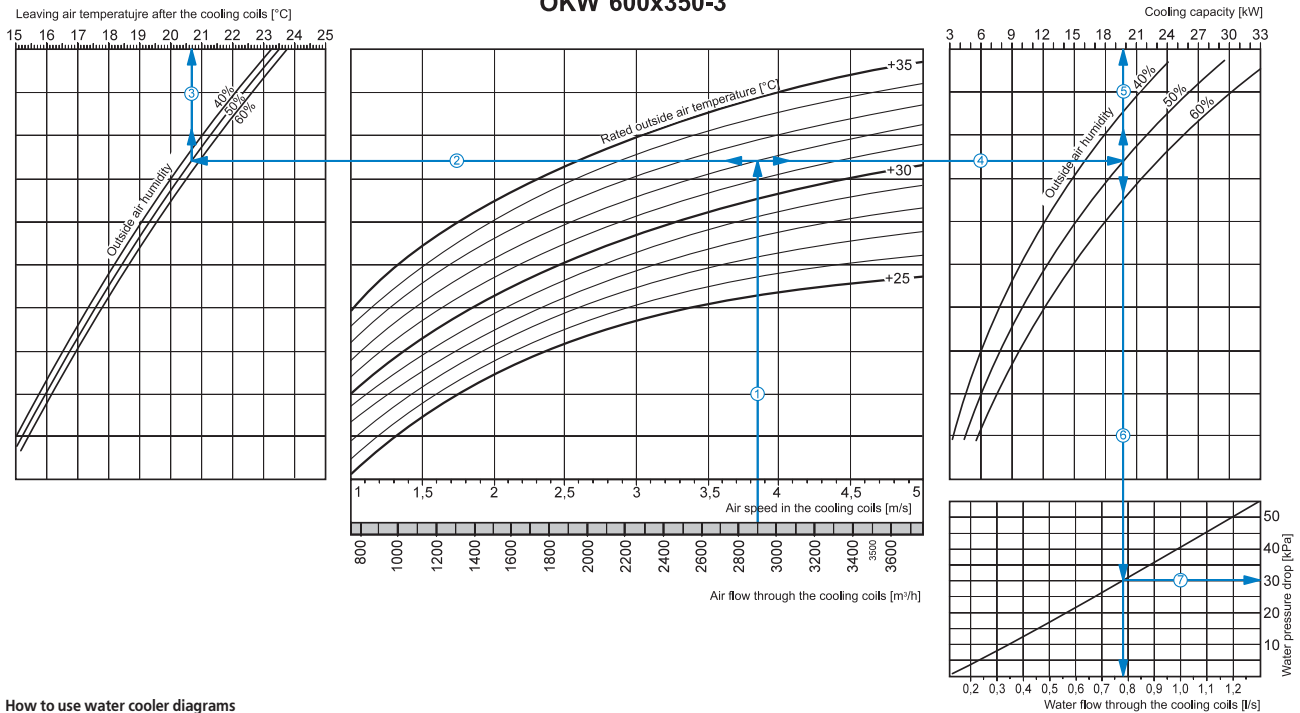

#### How to use water cooler diagrams

Air Speed. Starting from 2850 m<sup>3</sup>/h on the air flow scale draw a vertical line ① till the air speed axis. It makes 3.85 m/s.

- Supply air temperature. prolong the line ① up to the point where it crosses the outside air temperature (e.g. +32°C); then draw a horizontal line ② from this point to the left till crossing the outside air humidity (e.g. 50%). From this point draw a vertical line ③ to the supply air temperature at cooler outlet axis on top of the graphic (+20.7°C).
- Cooling capacity. Prolong the line ① up to the point where it crosses the outside air temperature (e.g. +32°C) and draw a horizontal line ④ from this point to the right until it crosses the outside air humidity curve (e.g., 50%), from here draw a vertical line ⑤ up to the scale representing the cooling capacity (19.8 kW).
- Water flow. Prolong the line ⑤ down to water flow axis at the bottom of the graphic ⑥ (0.78 l/s).
- Water pressure drop. Draw the line ⑦ from the point where the line ⑥ crosses the black curve to the pressure drop axis. (30.0 kPa).

OKW

OKW 700x400-3

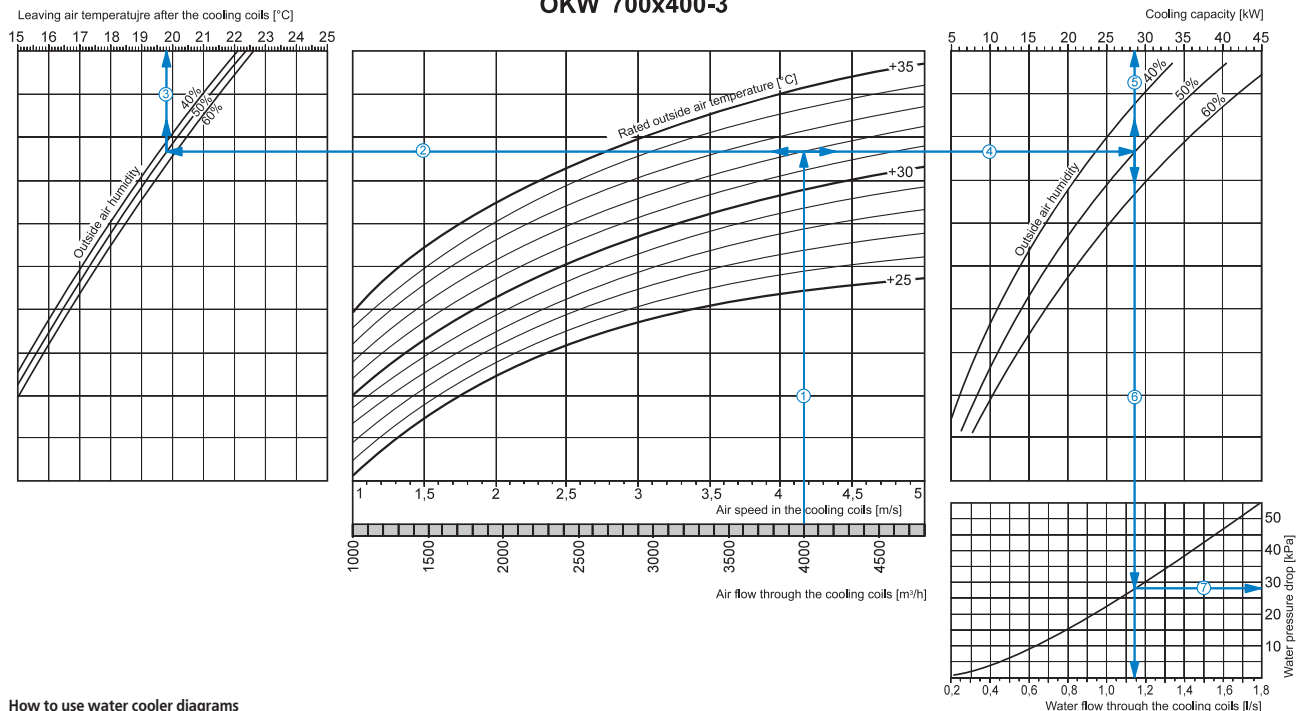

How to use water cooler diagrams

- Air Speed. Starting from 4000 m³/h on the air flow scale draw a vertical line ① till the air speed axis. It makes 4.15 m/s.
- Supply air temperature. prolong the line ① up to the point where it crosses the outside air temperature (e.g. +32°C); then draw a horizontal line ② from this point to the left till crossing the outside air humidity (e.g. 50%). From this point draw a vertical line ③ to the supply air temperature at cooler outlet axis on top of the graphic (+19.8°C).
- Cooling capacity. Prolong the line ① up to the point where it crosses the outside air temperature (e.g. +32°C) and draw a horizontal line ④ from this point to the right until it crosses the outside air humidity curve (e.g., 50%), from here draw a vertical line ⑤ up to the scale representing the cooling capacity (28.5 kW).
- Water flow. Prolong the line ⑤ down to water flow axis at the bottom of the graphic ⑥ (1.14 l/s).
- Water pressure drop. Draw the line ⑦ from the point where the line ⑥ crosses the black curve to the pressure drop axis. (28.0 kPa).

OKW

OKW 800x500-3

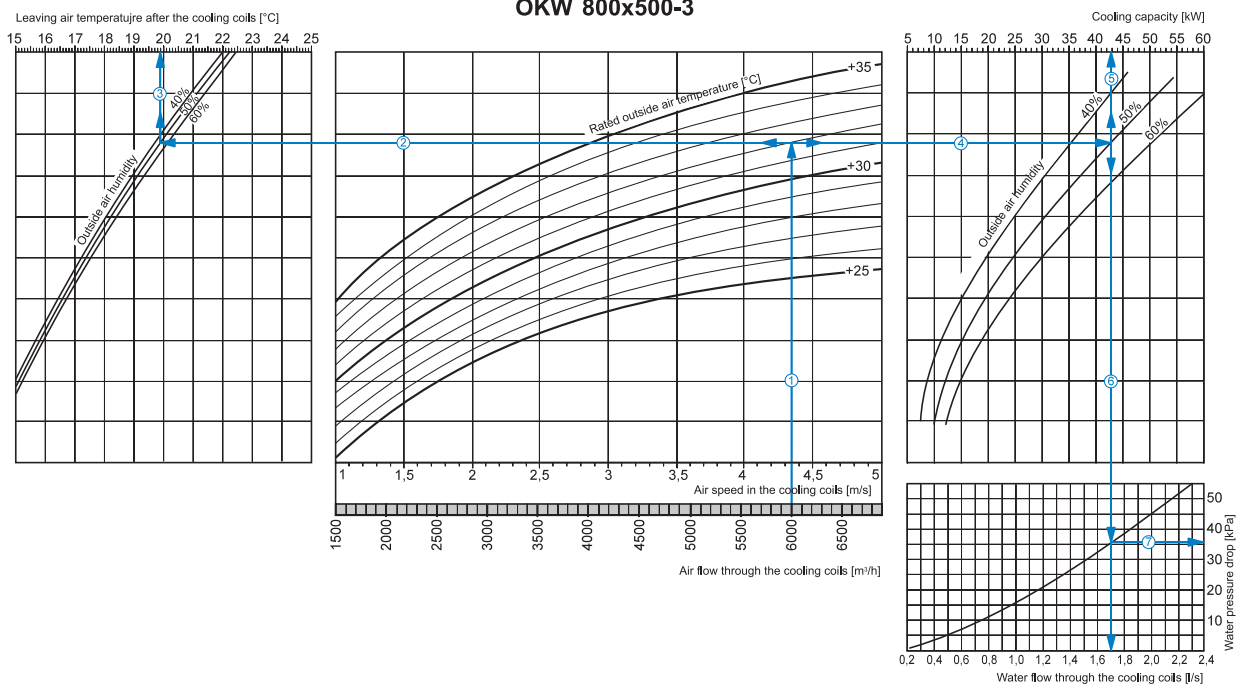

How to use water cooler diagrams

- Air Speed. Starting from 6000 m³/h on the air flow scale draw a vertical line ① till the air speed axis. It makes 4.35 m/s.
- Supply air temperature. prolong the line ① up to the point where it crosses the outside air temperature (e.g. +32°C); then draw a horizontal line ② from this point to the left till crossing the outside air humidity (e.g. 50%). From this point draw a vertical line ③ to the supply air temperature at cooler outlet axis on top of the graphic (+19.9°C).
- Cooling capacity. Prolong the line ① up to the point where it crosses the outside air temperature (e.g. +32°C) and draw a horizontal line ④ from this point to the right until it crosses the outside air humidity curve (e.g., 50%), from here draw a vertical line ⑤ up to the scale representing the cooling capacity (43 kW).
- Water flow. Prolong the line ⑤ down to water flow axis at the bottom of the graphic ⑥ (1.7 l/s).
- Water pressure drop. Draw the line ⑦ from the point where the line ⑥ crosses the black curve to the pressure drop axis. (36.0 kPa).

OKW

### OKW 900x500-3

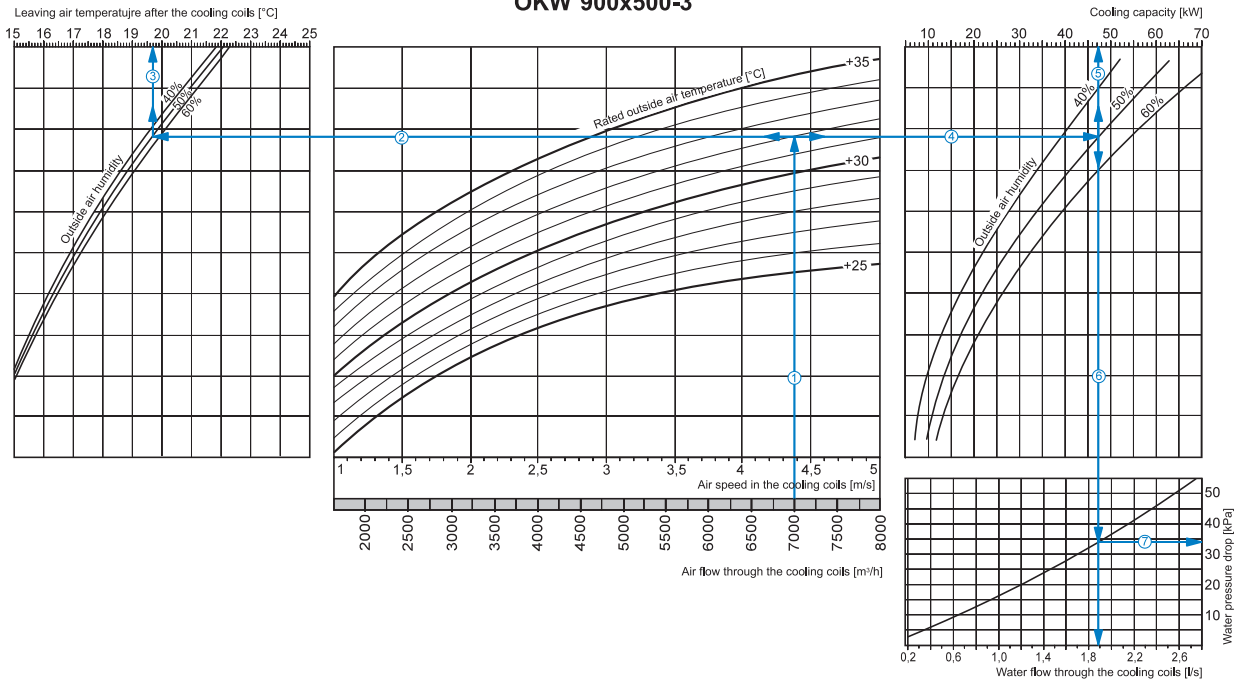

#### How to use water cooler diagrams

Air Speed. Starting from 7000 m<sup>3</sup>/h on the air flow scale draw a vertical line ① till the air speed axis. It makes 4.4 m/s.

Supply air temperature. prolong the line ① up to the point where it crosses the outside air temperature (e.g. +32°C); then draw a horizontal line ② from this point to the left till crossing the outside air humidity (e.g. 50%). From this point draw a vertical line ③ to the supply air temperature at cooler outlet axis on top of the graphic (+19.7°C).

Cooling capacity. Prolong the line ① up to the point where it crosses the outside air temperature (e.g. +32°C) and draw a horizontal line ④ from this point to the right until it crosses the outside air humidity curve (e.g., 50%), from here draw a vertical line ⑤ up to the scale representing the cooling capacity (47.0 kW).

Water flow. Prolong the line ⑤ down to water flow axis at the bottom of the graphic ⑥ (1.9 l/s).

Water pressure drop. Draw the line ⑦ from the point where the line ⑥ crosses the black curve to the pressure drop axis. (34.0 kPa).

OKW

### OKW 1000x500-3

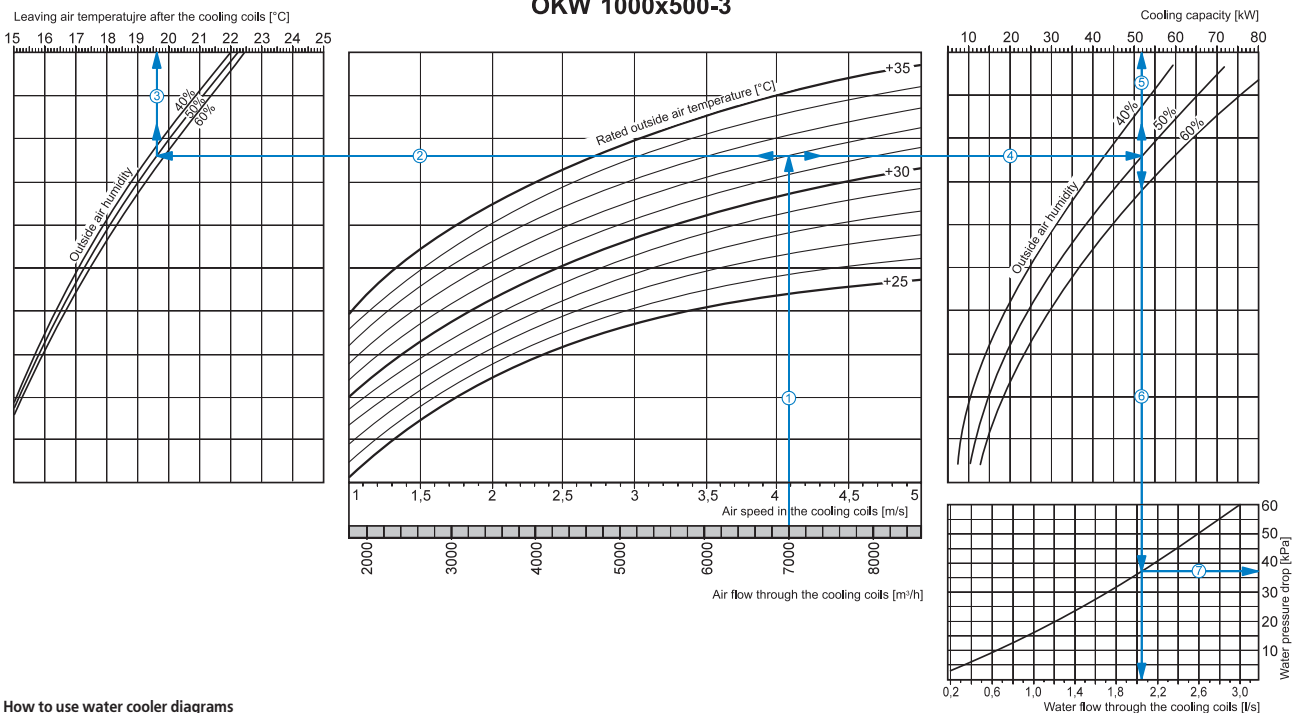

#### How to use water cooler diagrams

Air Speed. Starting from 7000 m<sup>3</sup>/h on the air flow scale draw a vertical line ① till the air speed axis. It makes 4.1 m/s.

Supply air temperature. prolong the line ① up to the point where it crosses the outside air temperature (e.g. +32°C); then draw a horizontal line ② from this point to the left till crossing the outside air humidity (e.g. 50%). From this point draw a vertical line ③ to the supply air temperature at cooler outlet axis on top of the graphic (+19.6°C).

Cooling capacity. Prolong the line ① up to the point where it crosses the outside air temperature (e.g. +32°C) and draw a horizontal line ④ from this point to the right until it crosses the outside air humidity curve (e.g., 50%), from here draw a vertical line ⑤ up to the scale representing the cooling capacity (52.0 kW).

Water flow. Prolong the line ⑤ down to water flow axis at the bottom of the graphic ⑥ (2.05 l/s).

Water pressure drop. Draw the line ⑦ from the point where the line ⑥ crosses the black curve to the pressure drop axis. (37.0 kPa).

Series  
**OKF**



■ **Applications**

Direct-expansion duct coolers are designed for cooling of supply air in rectangular ventilation systems and can be used either for supply or supply and exhaust units.

■ **Design**

The cooler casing is made of galvanized sheet steel, the piping is made of copper tubes and the heat exchange surface is made of aluminium plates. The coolers are available in 3 rows modification and designed for operation with R123, R134a, R152a, R404a, R407c, R410a, R507, R12, R22 cooling agents. The coolers are equipped with the drain pan for condensate collecting and draining.

■ **Mounting**

- ▶ Mounting is effected by means of flange connection. Direct-expansion cooling coils, can be installed horizontally only to enable the condensate draining.
- ▶ Installation shall be performed in such a way as to provide the uniform air stream distribution along the entire cross section.
- ▶ The air filter shall be installed at the cooler inlet to ensure the cooler protection against dirt and dusting.
- ▶ The cooler can be installed at the fan inlet or outlet. If the cooler is located at the fan outlet the air duct between the cooler and the fan shall be at least 1-1,5 m long to ensure the air stream stabilization.
- ▶ The cooler shall be connected on the counterflow basis to provide its maximum cooling capacity. All the nomographic charts in the catalogue are valid for such connection.
- ▶ The droplet separator which is ordered separately can be installed at the cooler outlet if the air speed exceeds 2.5 m/s. That prevents the condensate drop penetration into the air duct system.
- ▶ Condensate draining from the cooler shall be performed through the U-trap. The U-trap height depends on the total pressure in the fan. The trap height can be calculated using the figure and the table below.

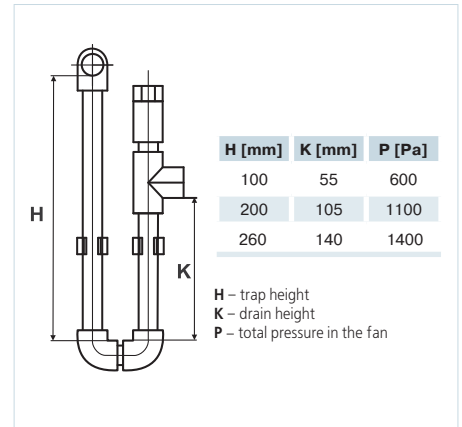

- ▶ To ensure the correct and safe cooler operation use the automation system providing the complex control and automatic regulation of the cooling capacity and air cooling temperature.

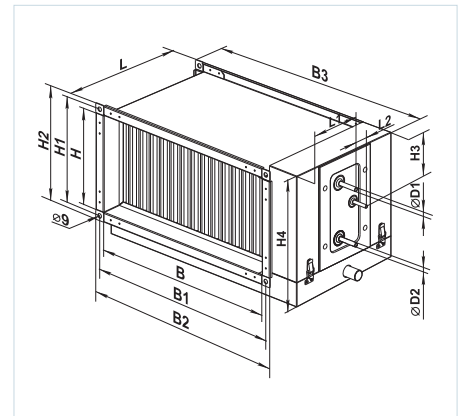

**Overall dimensions:**

Type	Dimensions [mm]													
	∅D1	∅D2	B	B1	B2	B3	H	H1	H2	H3	H4	L	L1	L2
OKF 400x200-3	12	22	400	420	438	528	200	220	238	70	273	395	165	60
OKF 500x250-3	12	22	500	520	538	628	250	270	288	120	323	395	165	60
OKF 500x300-3	12	22	500	520	538	628	300	320	338	175	373	395	165	60
OKF 600x300-3	18	28	600	620	638	728	300	320	338	170	373	395	165	60
OKF 600x350-3	18	28	600	620	638	728	350	370	388	220	423	395	165	60
OKF 700x400-3	22	28	700	720	738	858	400	420	438	250	473	395	160	75
OKF 800x500-3	22	28	800	820	838	958	500	520	538	340	573	395	160	75
OKF 900x500-3	22	28	900	920	938	1058	500	520	538	350	573	395	160	75
OKF 1000x500-3	22	28	1000	1020	1038	1158	500	520	538	350	573	395	160	75

**Designation key:**

<b>Series</b>	<b>Flange designation (WxH) [mm]</b>	-	<b>Number of cooling coils</b>
OKF	400x200; 500x250; 500x300; 600x300; 600x350; 700x400; 800x500; 900x500; 1000x500		3

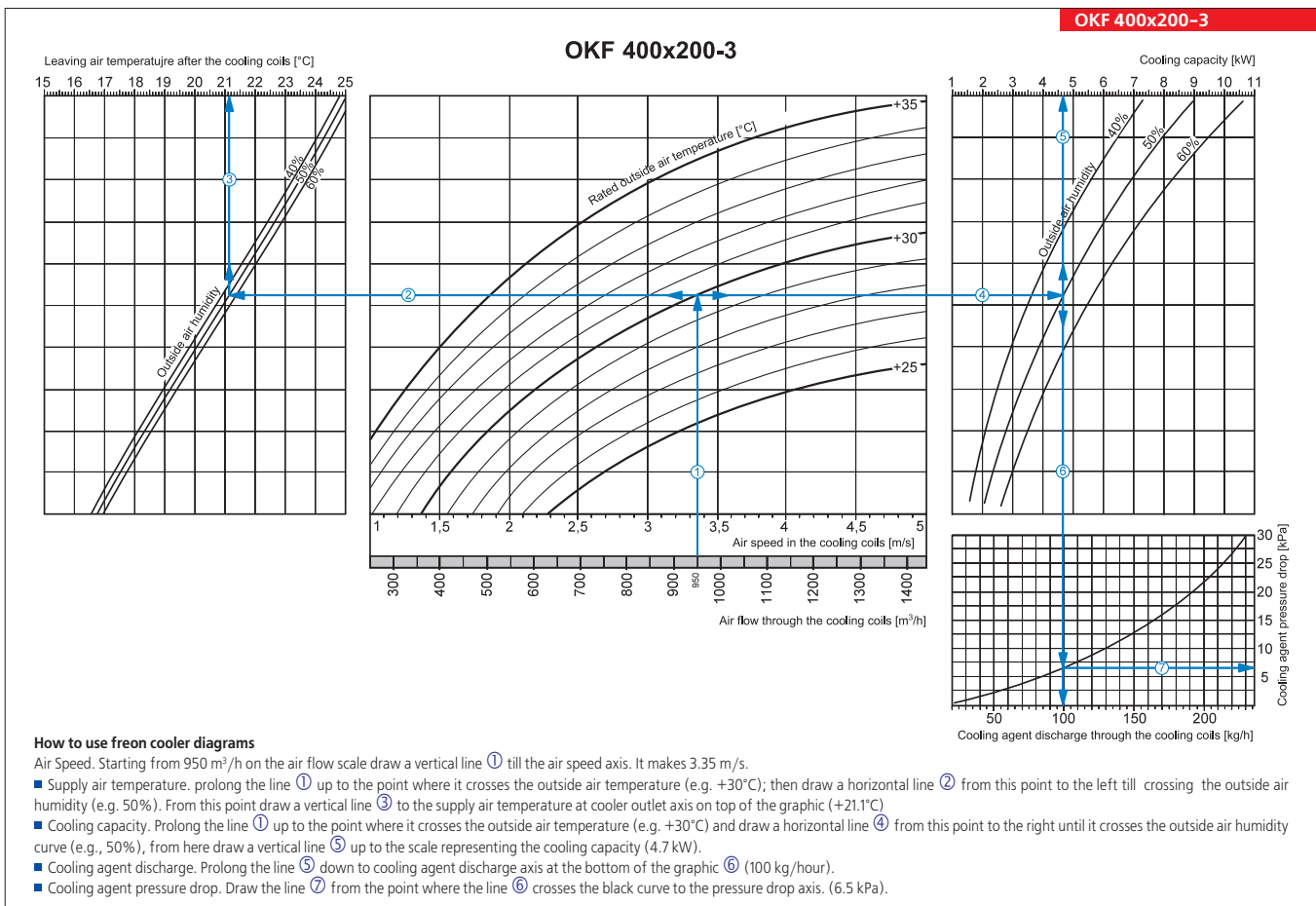
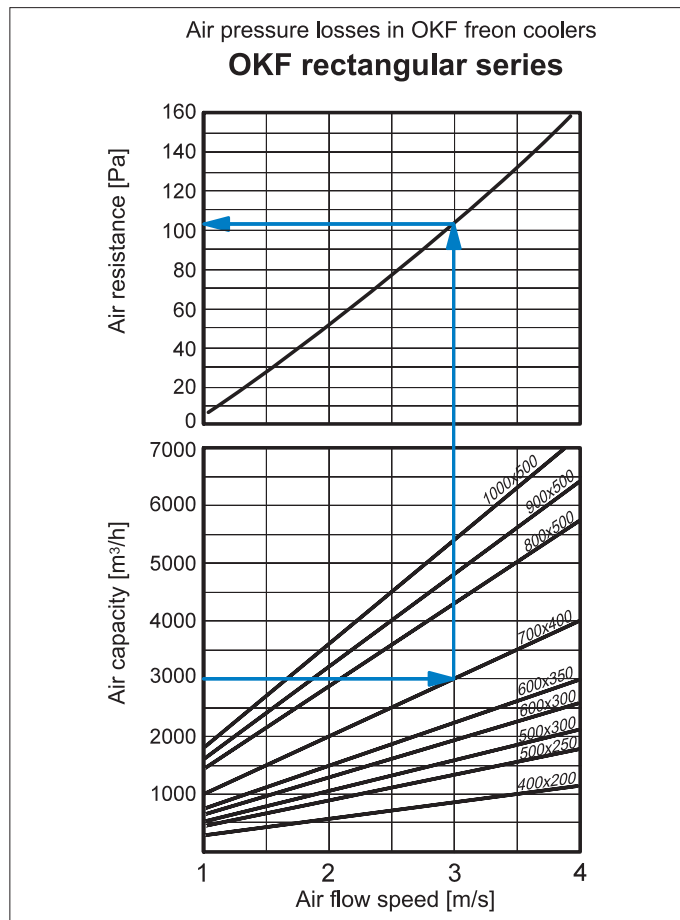



OKF 500x250-3

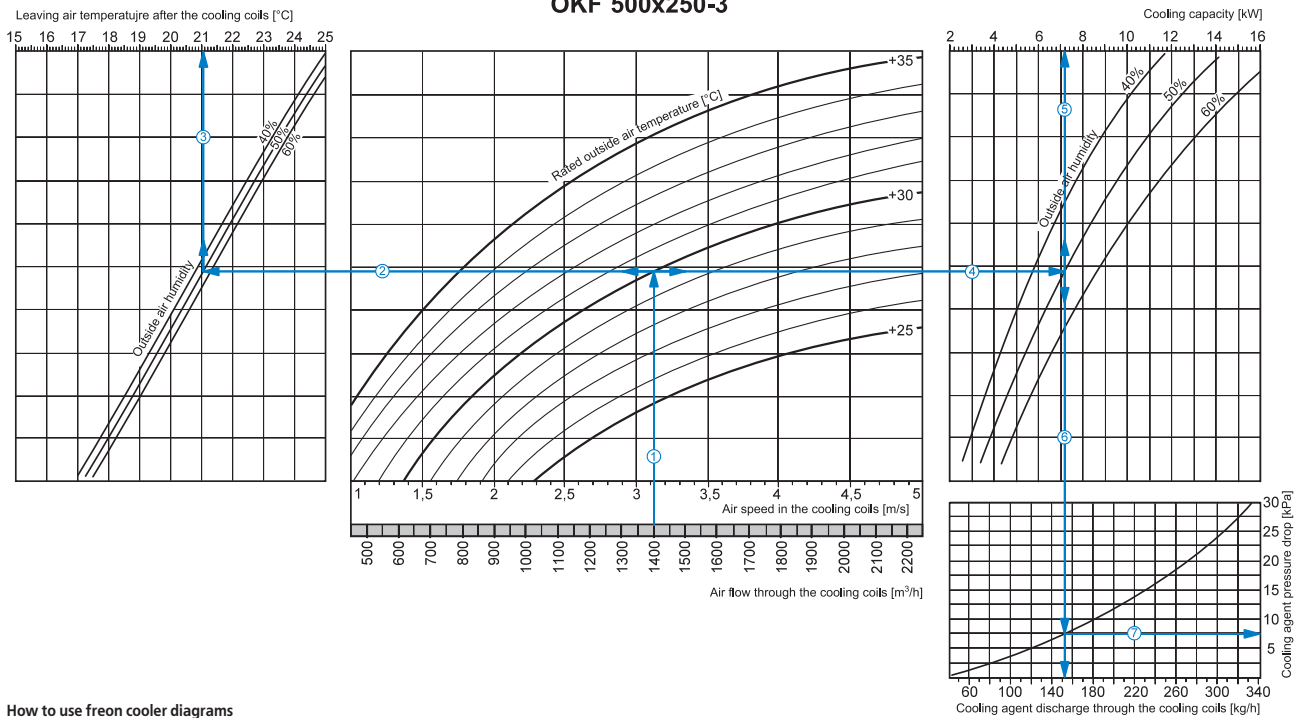

How to use freon cooler diagrams

- Air Speed. Starting from 1400 m<sup>3</sup>/h on the air flow scale draw a vertical line ① till the air speed axis. It makes 3.1 m/s.
- Supply air temperature. prolong the line ① up to the point where it crosses the outside air temperature (e.g. +30°C); then draw a horizontal line ② from this point to the left till crossing the outside air humidity (e.g. 50%). From this point draw a vertical line ③ to the supply air temperature at cooler outlet axis on top of the graphic (+21.1°C).
- Cooling capacity. Prolong the line ① up to the point where it crosses the outside air temperature (e.g. +30°C) and draw a horizontal line ④ from this point to the right until it crosses the outside air humidity curve (e.g., 50%), from here draw a vertical line ⑤ up to the scale representing the cooling capacity (7.2 kW).
- Cooling agent discharge. Prolong the line ⑤ down to cooling agent discharge axis at the bottom of the graphic ⑥ (152 kg/hour).
- Cooling agent pressure drop. Draw the line ⑦ from the point where the line ⑥ crosses the black curve to the pressure drop axis. (7.5 kPa).

OKF 500x300-3

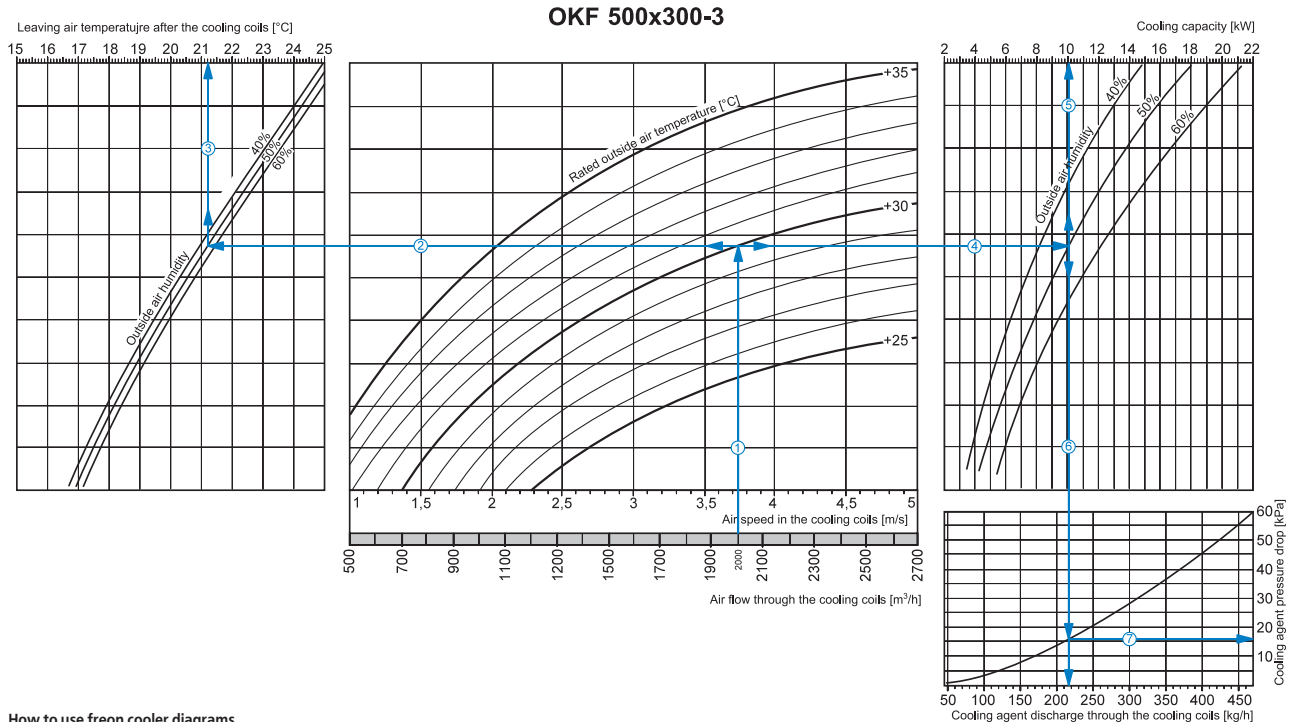

How to use freon cooler diagrams

- Air Speed. Starting from 2000 m<sup>3</sup>/h on the air flow scale draw a vertical line ① till the air speed axis. It makes 3.75 m/s.
- Supply air temperature. prolong the line ① up to the point where it crosses the outside air temperature (e.g. +30°C); then draw a horizontal line ② from this point to the left till crossing the outside air humidity (e.g. 50%). From this point draw a vertical line ③ to the supply air temperature at cooler outlet axis on top of the graphic (+21.2°C).
- Cooling capacity. Prolong the line ① up to the point where it crosses the outside air temperature (e.g. +30°C) and draw a horizontal line ④ from this point to the right until it crosses the outside air humidity curve (e.g., 50%), from here draw a vertical line ⑤ up to the scale representing the cooling capacity (10 kW).
- Cooling agent discharge. Prolong the line ⑤ down to cooling agent discharge axis at the bottom of the graphic ⑥ (215 kg/hour).
- Cooling agent pressure drop. Draw the line ⑦ from the point where the line ⑥ crosses the black curve to the pressure drop axis. (16.0 kPa).

**OKF 600x300-3**

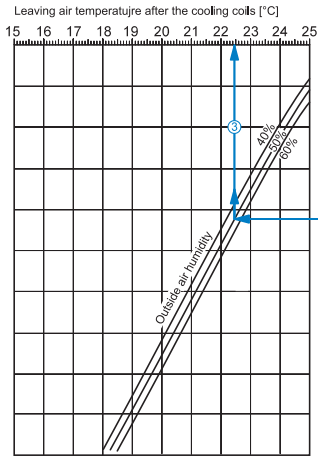

**OKF 600x300-3**

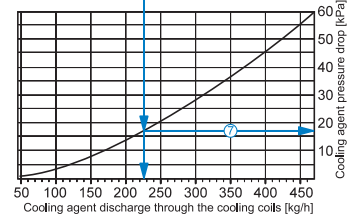
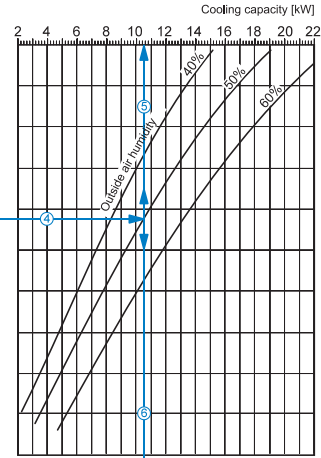
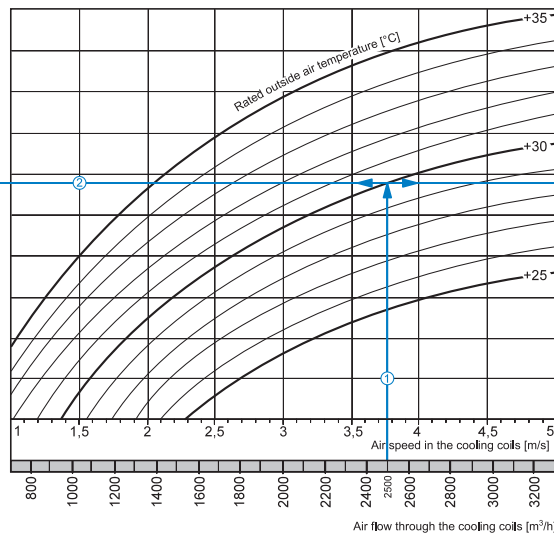

**How to use freon cooler diagrams**

**Air Speed.** Starting from 2500 m<sup>3</sup>/h on the air flow scale draw a vertical line ① till the air speed axis. It makes 3.75 m/s.

■ **Supply air temperature.** prolong the line ① up to the point where it crosses the outside air temperature (e.g. +30°C); then draw a horizontal line ② from this point to the left till crossing the outside air humidity (e.g. 50%). From this point draw a vertical line ③ to the supply air temperature at cooler outlet axis on top of the graphic (+22.5°C).

■ **Cooling coil capacity.** Prolong the line ① up to the point where it crosses the outside air temperature (e.g. +30°C) and draw a horizontal line ④ from this point to the right until it crosses the outside air humidity curve (e.g., 50%), from here draw a vertical line ⑤ up to the scale representing the cooling capacity (10.5 kW).

■ **Cooling agent discharge.** Prolong the line ⑤ down to cooling agent discharge axis at the bottom of the graphic ⑥ (225 kg/hour).

■ **Cooling agent pressure drop.** Draw the line ⑦ from the point where the line ⑥ crosses the black curve to the pressure drop axis. (17.0 kPa).

**OKF 600x350-3**

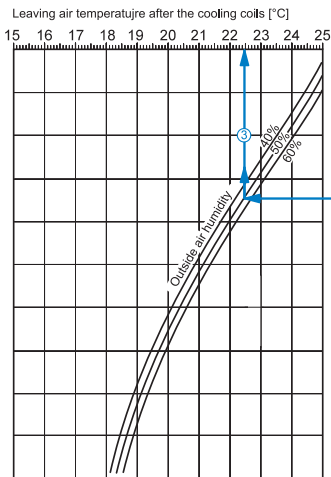

**OKF 600x350-3**

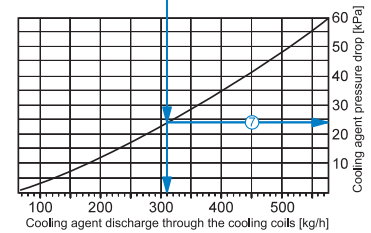
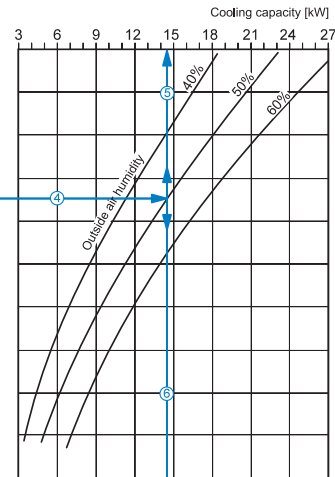
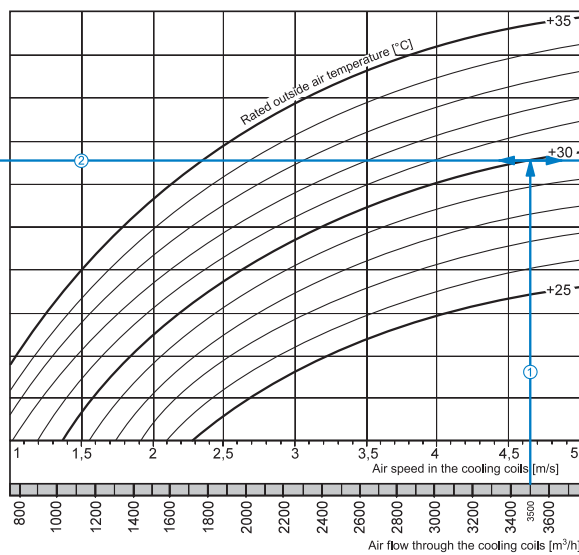

**How to use freon cooler diagrams**

**Air Speed.** Starting from 3500 m<sup>3</sup>/h on the air flow scale draw a vertical line ① till the air speed axis. It makes 4.65 m/s.

■ **Supply air temperature.** prolong the line ① up to the point where it crosses the outside air temperature (e.g. +30°C); then draw a horizontal line ② from this point to the left till crossing the outside air humidity (e.g. 50%). From this point draw a vertical line ③ to the supply air temperature at cooler outlet axis on top of the graphic (+22.5°C).

■ **Cooling coil capacity.** Prolong the line ① up to the point where it crosses the outside air temperature (e.g. +30°C) and draw a horizontal line ④ from this point to the right until it crosses the outside air humidity curve (e.g., 50%), from here draw a vertical line ⑤ up to the scale representing the cooling capacity (14.5 kW).

■ **Cooling agent discharge.** Prolong the line ⑤ down to cooling agent discharge axis at the bottom of the graphic ⑥ (310 kg/hour).

■ **Cooling agent pressure drop.** Draw the line ⑦ from the point where the line ⑥ crosses the black curve to the pressure drop axis. (24.0 kPa).

OKF 700x400-3

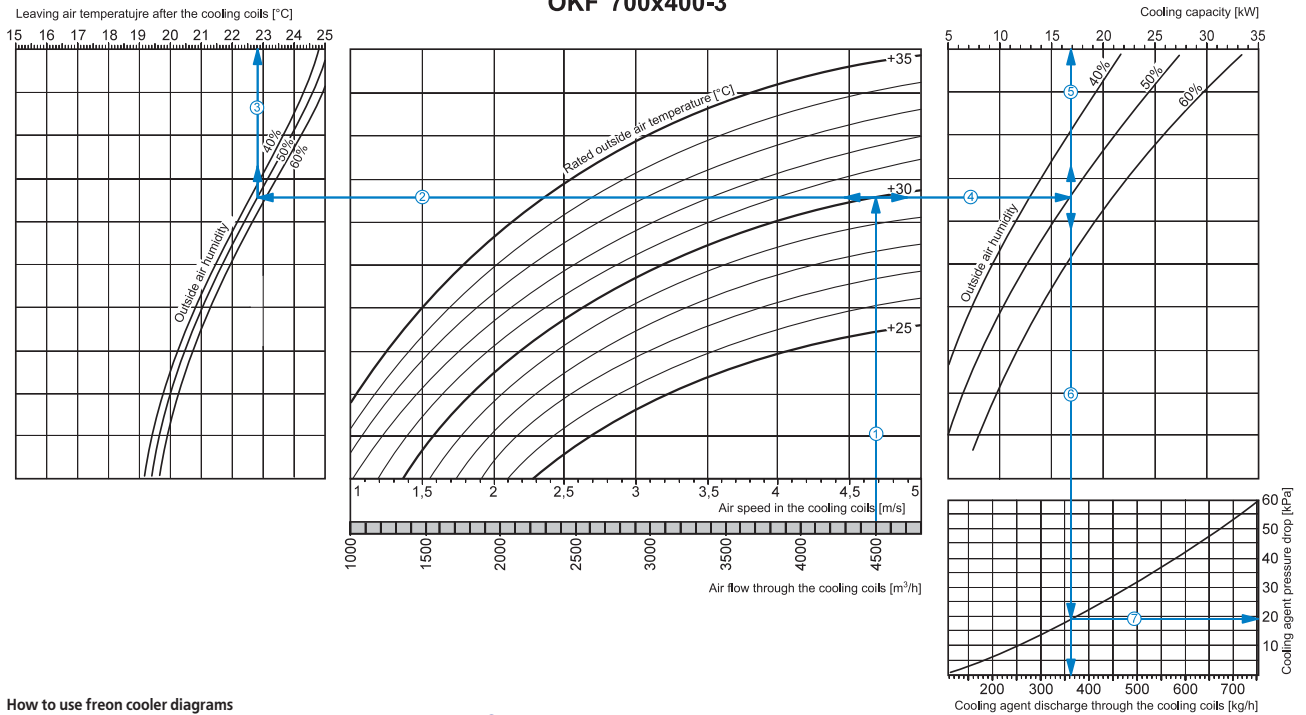

How to use freon cooler diagrams

- Air Speed. Starting from 4500 m<sup>3</sup>/h on the air flow scale draw a vertical line ① till the air speed axis. It makes 4.7 m/s.
- Supply air temperature. Prolong the line ① up to the point where it crosses the outside air temperature (e.g. +30°C); then draw a horizontal line ② from this point to the left till crossing the outside air humidity (e.g. 50%). From this point draw a vertical line ③ to the supply air temperature at cooler outlet axis on top of the graphic (+22.8°C).
- Cooling coil capacity. Prolong the line ① up to the point where it crosses the outside air temperature (e.g. +30°C) and draw a horizontal line ④ from this point to the right until it crosses the outside air humidity curve (e.g., 50%), from here draw a vertical line ⑤ up to the scale representing the cooling capacity (17.0 kW).
- Cooling agent discharge. Prolong the line ⑤ down to cooling agent discharge axis at the bottom of the graphic ⑥ (360 kg/hour).
- Cooling agent pressure drop. Draw the line ⑦ from the point where the line ⑥ crosses the black curve to the pressure drop axis. (19.0 kPa).

OKF 800x500-3

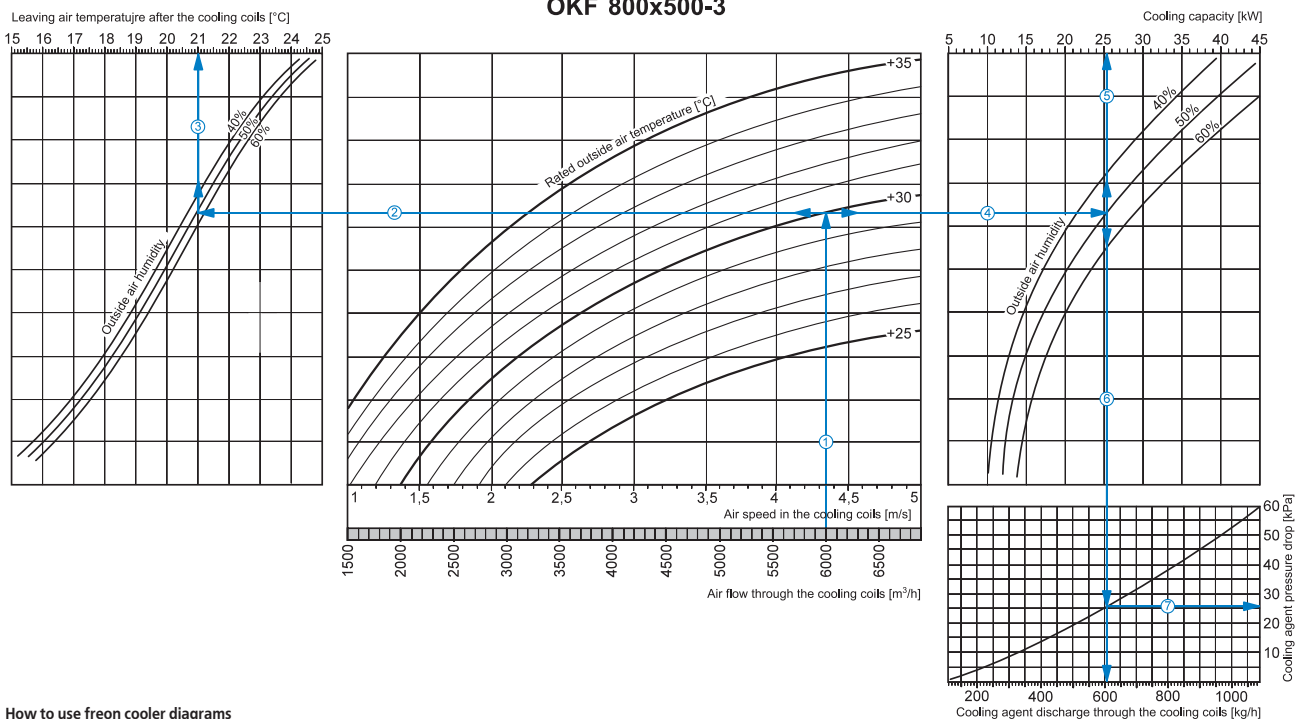

How to use freon cooler diagrams

- Air Speed. Starting from 6000 m<sup>3</sup>/h on the air flow scale draw a vertical line ① till the air speed axis. It makes 4.35 m/s.
- Supply air temperature. Prolong the line ① up to the point where it crosses the outside air temperature (e.g. +30°C); then draw a horizontal line ② from this point to the left till crossing the outside air humidity (e.g. 50%). From this point draw a vertical line ③ to the supply air temperature at cooler outlet axis on top of the graphic (+21.0°C).
- Cooling coil capacity. Prolong the line ① up to the point where it crosses the outside air temperature (e.g. +30°C) and draw a horizontal line ④ from this point to the right until it crosses the outside air humidity curve (e.g., 50%), from here draw a vertical line ⑤ up to the scale representing the cooling capacity (25.5 kW).
- Cooling agent discharge. Prolong the line ⑤ down to cooling agent discharge axis at the bottom of the graphic ⑥ (605 kg/hour).
- Cooling agent pressure drop. Draw the line ⑦ from the point where the line ⑥ crosses the black curve to the pressure drop axis. (26.0 kPa).

**OKF 900x500-3**

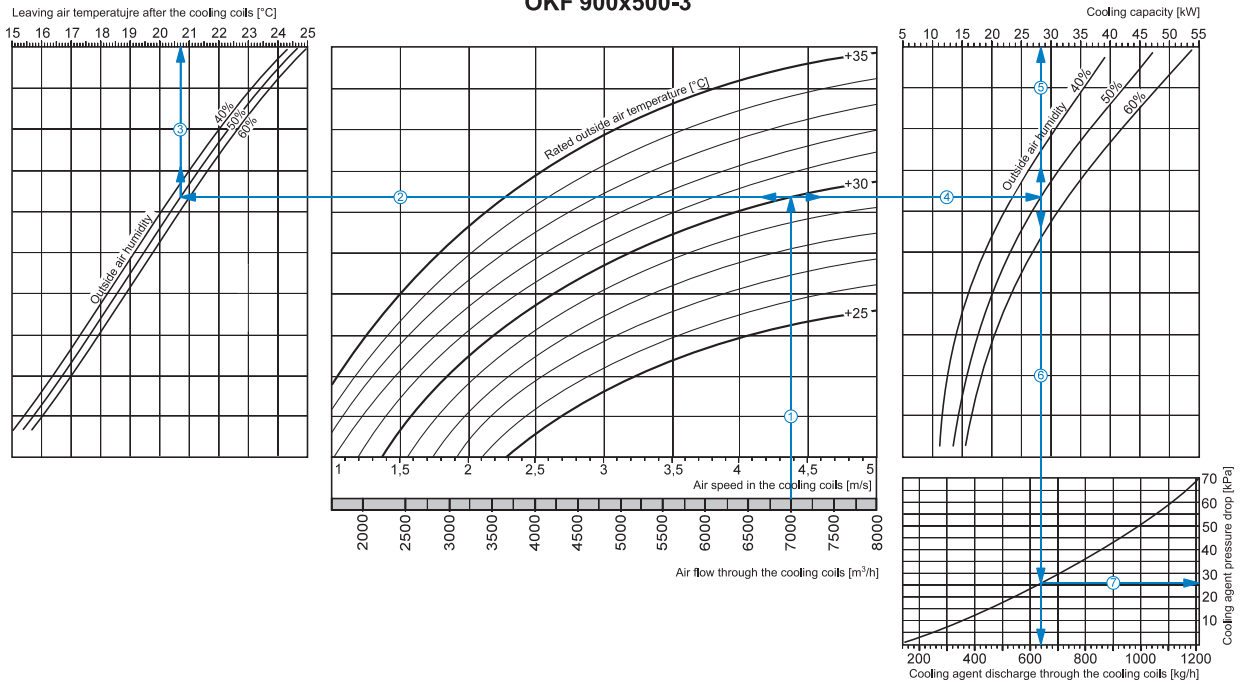

**How to use freon cooler diagrams**

Air Speed. Starting from 7000 m<sup>3</sup>/h on the air flow scale draw a vertical line ① till the air speed axis. It makes 4.4 m/s.

Supply air temperature. prolong the line ① up to the point where it crosses the outside air temperature (e.g. +30°C); then draw a horizontal line ② from this point to the left till crossing the outside air humidity (e.g. 50%). From this point draw a vertical line ③ to the supply air temperature at cooler outlet axis on top of the graphic (+20.7°C).

Cooling coil capacity. Prolong the line ① up to the point where it crosses the outside air temperature (e.g. +30°C) and draw a horizontal line ④ from this point to the right until it crosses the outside air humidity curve (e.g., 50%), from here draw a vertical line ⑤ up to the scale representing the cooling capacity (28.0 kW).

Cooling agent discharge. Prolong the line ⑤ down to cooling agent discharge axis at the bottom of the graphic ⑥ (640 kg/hour).

Cooling agent pressure drop. Draw the line ⑦ from the point where the line ⑥ crosses the black curve to the pressure drop axis. (26.0 kPa).

**OKF 1000x500-3**

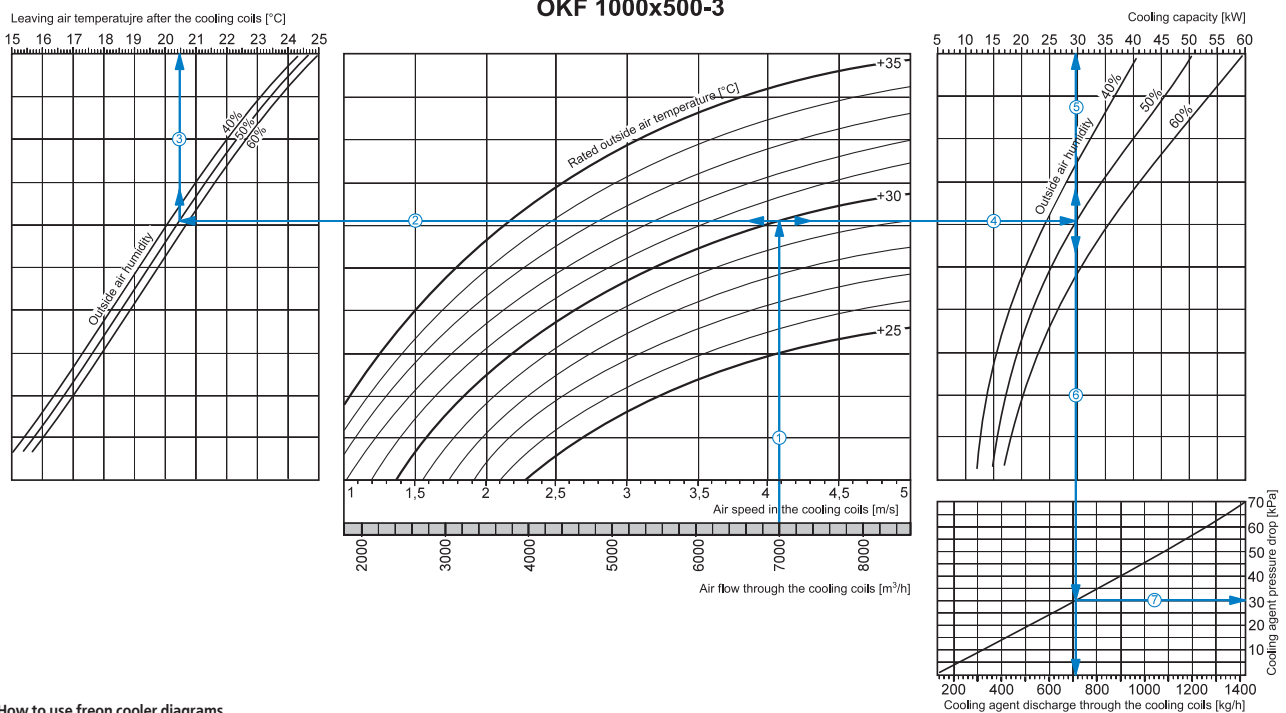

**How to use freon cooler diagrams**

Air Speed. Starting from 7000 m<sup>3</sup>/h on the air flow scale draw a vertical line ① till the air speed axis. It makes 4.1 m/s.

Supply air temperature. prolong the line ① up to the point where it crosses the outside air temperature (e.g. +30°C); then draw a horizontal line ② from this point to the left till crossing the outside air humidity (e.g. 50%). From this point draw a vertical line ③ to the supply air temperature at cooler outlet axis on top of the graphic (+20.5°C).

Cooling coil capacity. Prolong the line ① up to the point where it crosses the outside air temperature (e.g. +30°C) and draw a horizontal line ④ from this point to the right until it crosses the outside air humidity curve (e.g., 50%), from here draw a vertical line ⑤ up to the scale representing the cooling capacity (30.0 kW).

Cooling agent discharge. Prolong the line ⑤ down to cooling agent discharge axis at the bottom of the graphic ⑥ (710 kg/hour).

Cooling agent pressure drop. Draw the line ⑦ from the point where the line ⑥ crosses the black curve to the pressure drop axis. (30.0 kPa).

## Series KOM



### Applications

Backdraft spring-loaded damper designed for automatic shutoff of the round ducts and preventing back draft of air when ventilation system is switched off. Damper vanes are opened with the pressure generated by air stream and are closed by the spring.

### Design

The damper housing is made of galvanized steel and the vanes are made of aluminium sheet. The damper has two spring-loaded vanes.

### Mounting

The damper design ensures its mounting on the round air ducts by means of clamps. Ensure the vertical position of vane rotation axis. When installing the damper in the ventilation system the air stream direction shall be considered.

### Overall dimensions:

Type	Dimensions [mm]		Mass [kg]
	ØD	L	
KOM 100	99	80	0,18
KOM 125	124	100	0,27
KOM 150	149	115	0,38
KOM 160	159	120	0,42
KOM 200	199	145	0,63
KOM 250	249	165	0,90
KOM 315	314	190	1,31

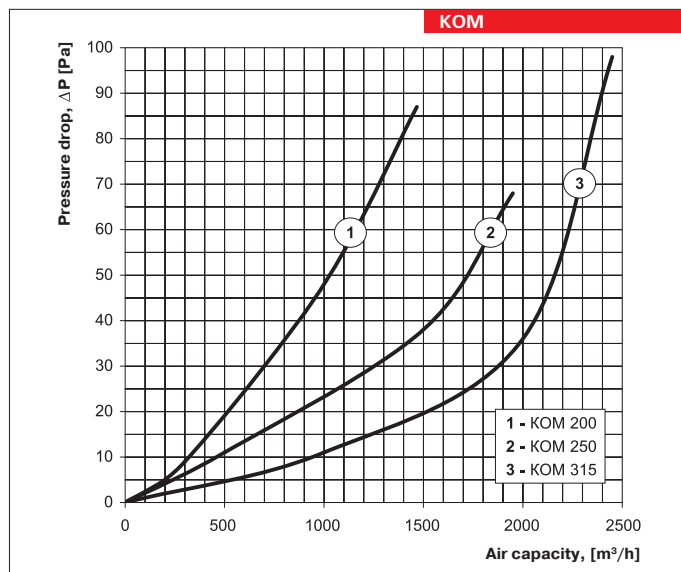
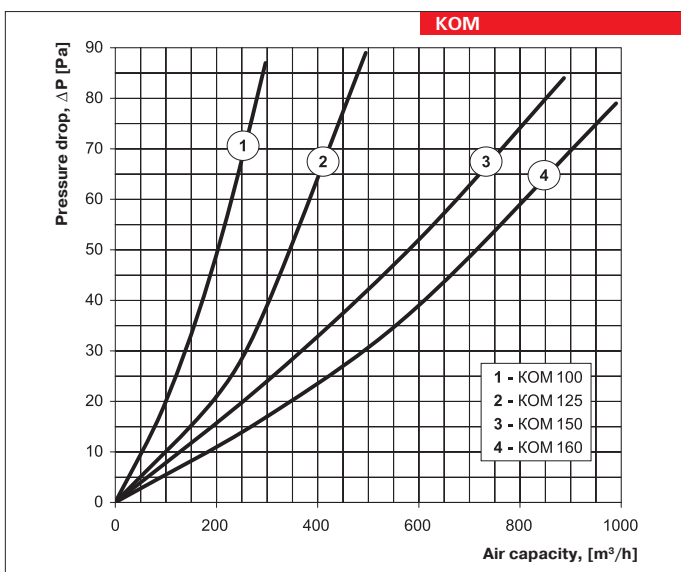
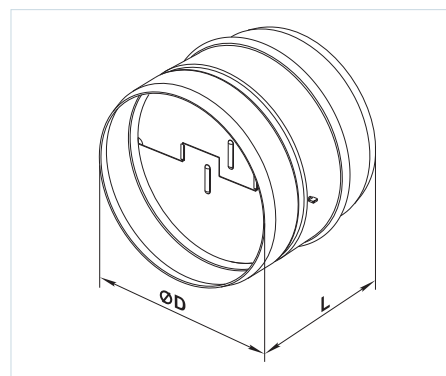

### Designation key:

Series	Flange diameter, [mm]
KOM	100; 125; 150; 160; 200; 250; 315



**BACKDRAFT DAMPERS**

**Series  
KOM1**



**Applications**

Backdraft damper based on gravitation actuation is designed for automatic duct shutoff and preventing air back draft.

**Design**

The casing and the rotary vane are made of galvanized sheet steel. The rubber seals provide airtight connection to the air ducts. The vane is opened by means of air flow and is closed automatically at no flow. The damper lever is equipped with a counter balancing weight to regulate the sensitivity of the damper opening/closing.

**Mounting**

The damper design ensures its mounting on the round ducts by means of clamps. The vane shall be gravitationally closed. While mounting the damper in the ventilation system consider the air stream direction.

**Series  
KOM1**



**Applications**

The backdraft damper based on gravitation actuation is designed for automatic air duct shutoff when the fan is switched off.

**Design**

The casing and the rotary vane are made of galvanized sheet steel. The vane is opened by means of air flow and is closed automatically at no flow. The damper lever is equipped with a counter balancing weight to regulate the sensitivity of the damper opening/closing.

**Mounting**

The damper is designed for mounting into rectangular air ducts of the ventilation systems with the horizontal position of the wide side. The vane is closed gravitationally. While mounting the damper in the ventilation system consider the air stream direction.

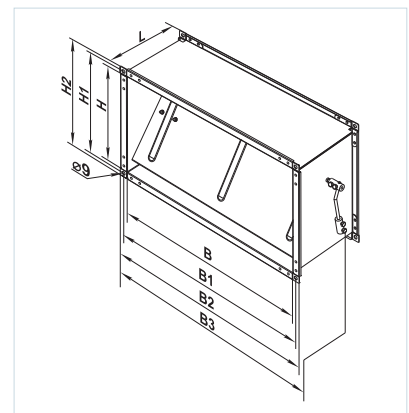
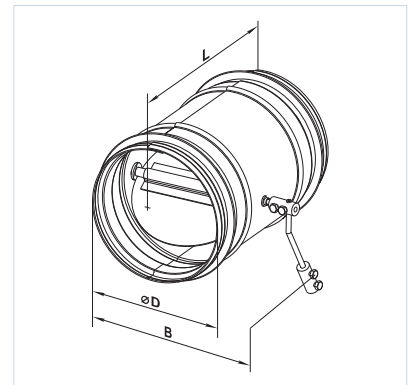

**Overall dimensions:**

Type	Dimensions [mm]			Mass [kg]
	øD	B	L	
KOM1 100	99	139	150	0,65
KOM1 125	124	162	170	0,81
KOM1 150	149	194	180	0,97
KOM1 160	159	204	190	1,06
KOM1 200	199	238	220	1,57
KOM1 250	249	290	270	2,2
KOM1 315	314	356	340	3,24

**Overall dimensions:**

Type	Dimensions [mm]								Mass [kg]
	B	B1	B2	B3	H	H1	H2	L	
KOM1 400x200	400	420	440	461	200	220	240	202	2,9
KOM1 500x250	500	520	540	561	200	270	290	202	3,73
KOM1 500x300	500	520	540	561	300	320	340	202	4,1
KOM1 600x300	600	620	640	661	300	320	340	202	4,64
KOM1 600x350	600	620	640	661	350	370	390	202	5,03

**Designation key:**

<b>Series</b> KOM 1	<b>Flange diameter, [mm]</b> 100; 125; 150; 160; 200; 250; 315	<b>Series</b> KOM 1	<b>Flange designation (WxH) [mm]</b> 400x200; 500x250; 500x300; 600x300; 600x350
------------------------	---	------------------------	---

BACKDRAFT DAMPER

KOM  
KOM1



Series  
**KR**



Series  
**KRA**



■ **Applications**

Air shutters are designed for manual air flow controlling (KR) or automatic round air duct shutoff (KRA).

■ **Design**

The casing and the rotary vane are made of galvanized

sheet steel. Provided with rubber seals for airtight connection to the air ducts.

**KR** - manually controlled air shutter equipped with metal leverage as well as locking device to fix the position by means of butterfly bolt.

**KRA** - air shutter equipped with an actuator to ensure automatic opening or closing of a ventilation duct.

■ **Mounting**

The air shutter design ensures its mounting on the round ducts by means of clamps. While mounting the automatic air shutters with actuator the space for easy access to the drive shall be ensured.

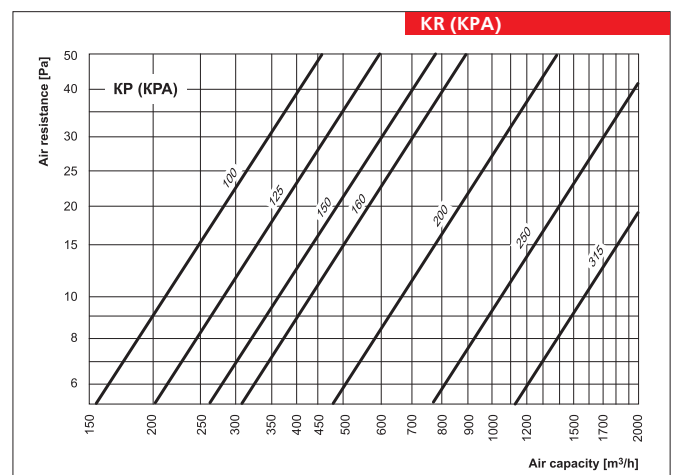
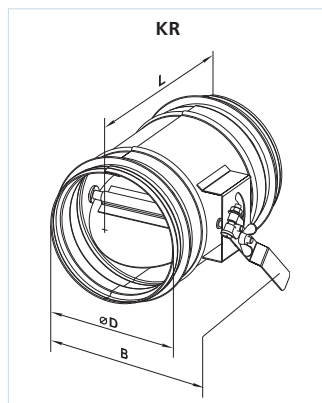
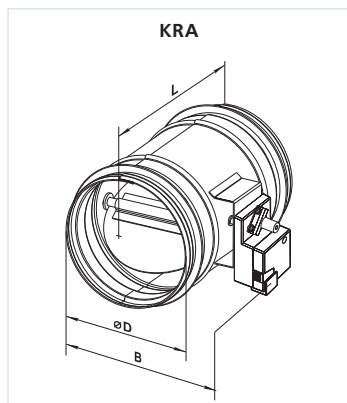

**Overall dimensions:**

Type	Dimensions [mm]			Mass [kg]
	ØD	B	L	
KRA 100	99	185	150	1,2
KRA 125	124	211	170	1,4
KRA 150	149	237	180	1,6
KRA 160	159	243	190	1,7
KRA 200	199	287	220	2,2
KRA 250	249	339	270	2,8
KRA 315	314	405	340	3,9
KRA 355	348	450	400	5,0

**Overall dimensions:**

Type	Dimensions [mm]			Mass [kg]
	ØD	B	L	
KR 100	99	131	150	0,6
KR 125	124	159	170	0,8
KR 150	149	186	180	0,96
KR 160	159	196	190	1,04
KR 200	199	230	220	1,56
KR 250	249	282	270	2,18
KR 315	314	348	340	3,23

**Designation key:**

Series	Flange diameter, [mm]
KR / KRA	100; 125; 150; 160; 200; 250; 315; 355

## AIR SHUTTERS

### Series KR



### Series KRA



#### Applications

Air shutters are designed for manual air flow controlling (KR) or automatic round air duct shutoff (KRA).

#### Design

The casing and the rotary vane are made of galvanized sheet steel.

**KR** - manually controlled air shutter equipped with metal leverage as well as locking device to fix the position by means of butterfly bolt.

**KRA** - air shutter equipped with an actuator to ensure automatic opening or closing of a ventilation duct.

#### Mounting

The shutter shall be mounted by means of a flange

connection. The mounting inside the ventilation system is performed through connection of the end flanges of the shutter to the mating flanges of the air ducts and other units of the system. The fixing is effected by means of galvanized bolts and brackets. While mounting the dampers with the actuator ensure easy access to the actuator.

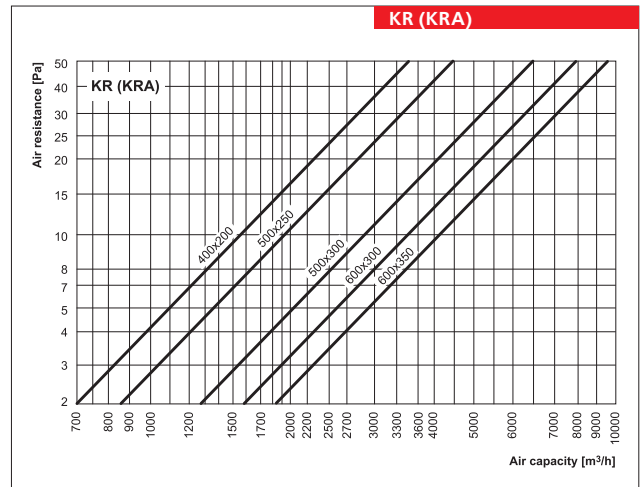
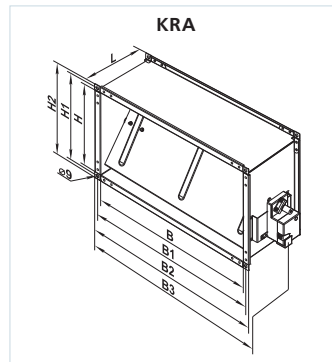
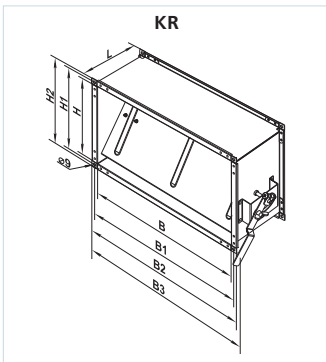

#### Overall dimensions:

Type	Dimensions [mm]								Mass [kg]
	B	B1	B2	B3	H	H1	H2	L	
KR 400x200	400	420	440	460	200	220	240	202	3,0
KR 500x250	500	520	540	560	250	270	290	202	3,8
KR 500x300	500	520	540	560	300	320	340	202	3,1
KR 600x300	600	620	640	660	300	320	340	202	4,2
KR 600x350	600	620	640	660	350	370	390	202	5,1

#### Overall dimensions:

Type	Dimensions [mm]								Mass [kg]
	B	B1	B2	B3	H	H1	H2	L	
KRA 400x200	400	420	440	503	200	220	240	202	3,6
KRA 500x250	500	520	540	603	250	270	290	202	4,4
KRA 500x300	500	520	540	603	300	320	340	202	4,8
KRA 600x300	600	620	640	703	300	320	340	202	5,4
KRA 600x350	600	620	640	703	350	370	390	202	5,8

#### Designation key:

Series	Flange designation (WxH) [mm]
KR / KRA	400x200; 500x250; 500x300; 600x300; 600x350

Series  
**RRV**



Series  
**RRVA**



■ **Applications**

The air flow control damper consists of a number of blades which close towards each other. It is designed for manual air flow control (RRV) or for automatic rectangular ventilation duct shutoff (RRVA, RRVAF).

■ **Design**

The casing is made of galvanized steel sheet. The blades are made of aluminium shape. The plastic gears enable their rotation.

**RRV** - manual air flow capacity regulator and shutoff

damper, equipped with metal leverage and locking device to fix the position by means of butterfly bolt.

**RRVA** - regulating and shutoff damper with the actuator to provide ventilation shaft automatic opening or shutoff.

**RRVAF** - regulating and shutoff damper with the actuator and the pullback spring for automatic shutting of ventilation duct. Shutter closing is effected by means of the spring actuator that enables the damper application as a component of freezing protection system for water heating.

■ **Mounting**

Mounting of air flow control damper is effected by means of flange connection. Mounting inside the ventilation system is performed through fastening of end flanges of shutters to the mating flanges of air ducts or other ventilation system units. The fastening is effected with galvanized bolts and clamps. While mounting the dampers with the actuator ensure easy access to the drive.

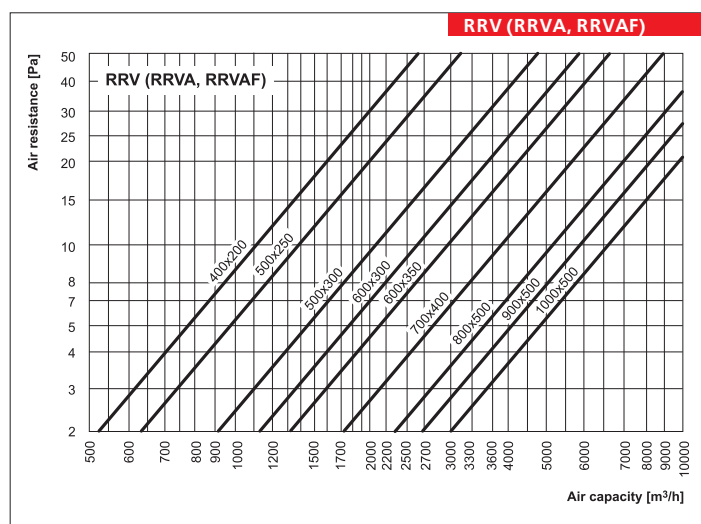

Designation key:

Series	Flange designation (WxH) [mm]
RRV RRVA RRVAF	400x200; 500x250; 500x300; 600x300; 600x350; 700x400; 800x500; 900x500; 1000x500

**Overall dimensions:**

Type	Dimensions [mm]								Mass [kg]
	B	B1	B2	B3	H	H1	H2	L	
RRV 400x200	400	420	440	475	200	220	240	170	3,5
RRV 500x250	500	520	540	575	250	270	290	170	4,2
RRV 500x300	500	520	540	575	300	320	340	170	4,9
RRV 600x300	600	620	640	675	300	320	340	170	5,4
RRV 600x350	600	620	640	675	350	370	390	170	5,7
RRV 700x400	700	720	740	775	400	420	440	170	7,7
RRV 800x500	800	820	840	875	500	520	540	170	8,8
RRV 900x500	900	920	940	975	500	520	540	170	9,6
RRV 1000x500	1000	1020	1040	1075	500	520	540	170	10,3

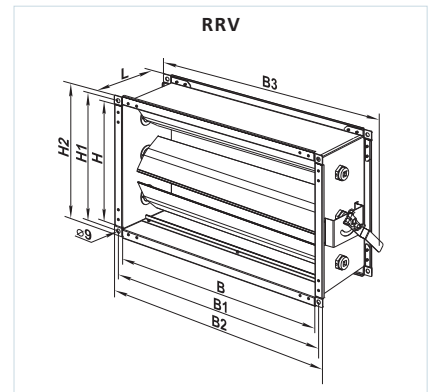

**Overall dimensions:**

Type	Dimensions [mm]								Mass [kg]
	B	B1	B2	B3	H	H1	H2	L	
RRVA 400x200	400	420	440	515	200	220	240	170	3,5
RRVA 500x250	500	520	540	615	250	270	290	170	4,2
RRVA 500x300	500	520	540	615	300	320	340	170	4,9
RRVA 600x300	600	620	640	715	300	320	340	170	5,4
RRVA 600x350	600	620	640	715	350	370	390	170	5,7
RRVA 700x400	700	720	740	815	400	420	440	170	8,0
RRVA 800x500	800	820	840	915	500	520	540	170	9,2
RRVA 900x500	900	920	940	1015	500	520	540	170	9,9
RRVA 1000x500	1000	1020	1040	1115	500	520	540	170	10,7

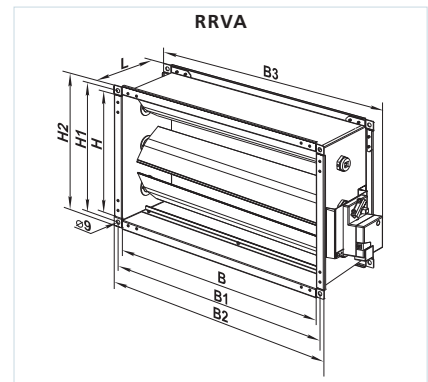

**Overall dimensions:**

Type	Dimensions [mm]								Mass [kg]
	B	B1	B2	B3	H	H1	H2	L	
RRVAF 400x200	400	420	440	530	200	220	240	170	4,5
RRVAF 500x250	500	520	540	630	250	270	290	170	5,2
RRVAF 500x300	500	520	540	630	300	320	340	170	5,9
RRVAF 600x300	600	620	640	730	300	320	340	170	6,4
RRVAF 600x350	600	620	640	730	350	370	390	170	6,7
RRVAF 700x400	700	720	740	830	400	420	440	170	9,1
RRVAF 800x500	800	820	840	930	500	520	540	170	10,2
RRVAF 900x500	900	920	940	1030	500	520	540	170	11
RRVAF 1000x500	1000	1020	1040	1030	500	520	540	170	11,7

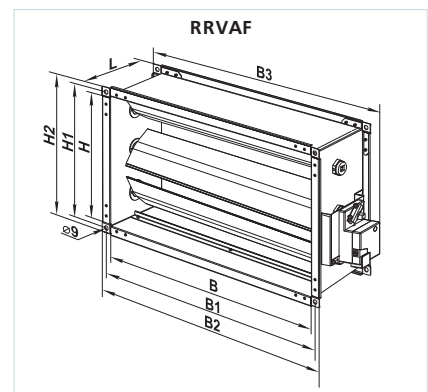

RRV  
RRVA  
RRVAF  
AIR FLOW CONTROL DAMPER

# LOUVRE BACKDRAFT SHUTTERS

## Series KG



### Applications

Louvre backdraft shutter based on gravitation actuation is designed for automatic air duct shutoff when fan is switched off.

### Design

The casing is made of galvanized steel. The louvre shutter is equipped with light plastic gravitationally actuated profiled vanes placed on pivot shafts that are built in the external grille. The damper vanes are opened due to the air pressure and automatically close when no flow.

### Mounting

The shutter is designed for mounting into rectangular air ducts with the horizontal position of the wide side. The vanes shall be gravitationally closed. The air stream direction shall be considered during mounting the louvre shutter into the ventilation system.

### Overall dimensions:

Type	Dimensions [mm]						Mass [kg]
	B	B1	B2	H	H1	H2	
KG 400x200	400	420	440	200	220	240	1,29
KG 500x250	500	520	540	250	270	290	1,58
KG 500x300	500	520	540	300	320	340	1,83
KG 600x300	600	620	640	300	320	340	2,05
KG 600x350	600	620	640	350	370	390	2,21
KG 700x400	700	720	740	400	420	440	3,0
KG 800x500	800	820	840	500	520	540	3,6
KG 900x500	900	920	940	500	520	540	3,8
KG 1000x500	1000	1020	1040	500	520	540	4,0

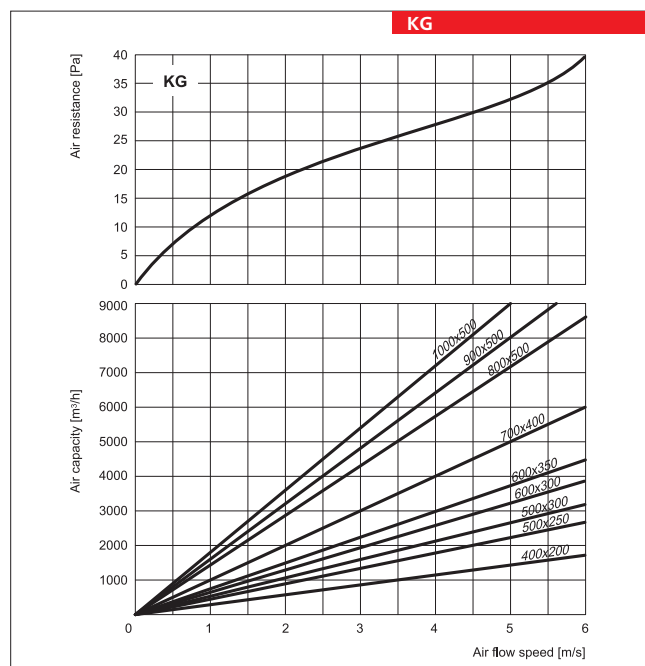
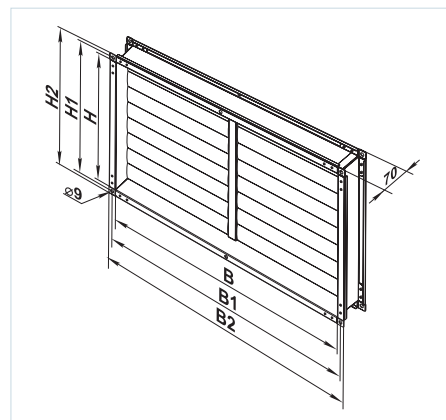

### Designation key:

Series	Flange designation (WxH) [mm]
KG	400x200; 500x250; 500x300; 600x300; 600x350; 700x400; 800x500; 900x500; 1000x500



## FLEXIBLE ANTI-VIBRATION CONNECTORS

### Series VVG / VVGF



#### Applications

Flexible connectors are designed to exclude the vibration transmission from fans or ventilating units to the air duct as well as for the thermal distortion

compensation within the air duct. Applied in ventilation systems with the transferred air temperature over the range of -40°C to +80°C.

#### Design

Flexible connectors are two flanges made of galvanized sheet steel interconnected by vibration-isolating material made of polyethylene tape reinforced with polyamide fiber. The connectors are not designed for mechanical load and cannot be used as a part of load-bearing construction.

#### Mounting

Mounting of flexible connector into the ventilation system is effected by means of end flanges fixing to the mating flanges in the ventilation system. Fixing is performed by means of galvanized bolts and brackets.

#### Overall dimensions:

Type	Dimensions [mm]				Mass, [kg]	Figure no.
	∅D	∅D1	∅D2	L		
VVG 100	101	-	-	130	0,14	1
VVG 125	126	-	-	130	0,17	1
VVG 150	151	-	-	130	0,21	1
VVG 160	161	-	-	130	0,22	1
VVG 200	201	-	-	130	0,28	1
VVG 250	251	-	-	130	0,35	1
VVG 315	316	-	-	130	0,44	1
VVG 355	356	-	-	130	0,50	1
VVG 400	401	-	-	130	0,56	1
VVG 450	451	-	-	130	0,64	1
VVG 500	501	-	-	130	0,71	1
VVGF 200	200	250	380	130	1,1	2
VVGF 250	250	295	320	130	1,4	2
VVGF 315	314	380	397	130	1,8	2
VVGF 355	355	442	460	130	2,0	2
VVGF 400	400	504	528	130	2,3	2
VVGF 450	450	578	607	130	2,8	2

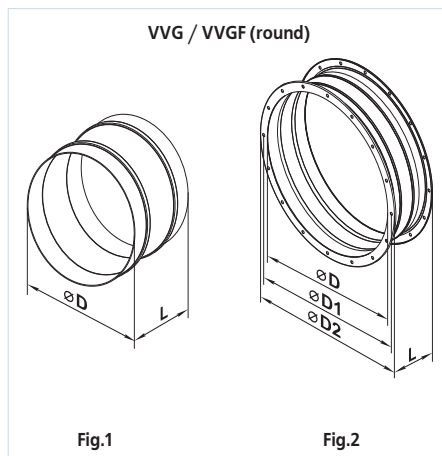

#### Overall dimensions:

Type	Dimensions [mm]						Mass [kg]
	B	B1	B2	H	H1	H2	
VVG 400x200	400	420	440	200	220	240	1,1
VVG 500x250	500	520	540	250	270	290	1,4
VVG 500x300	500	520	540	300	320	340	1,6
VVG 600x300	600	620	640	300	320	340	1,82
VVG 600x350	600	620	640	350	370	390	1,95
VVG 700x400	700	720	740	400	420	440	2,4
VVG 800x500	800	820	840	500	520	540	2,8
VVG 900x500	900	920	940	500	520	540	3,0
VVG 1000x500	1000	1020	1040	500	520	540	3,2

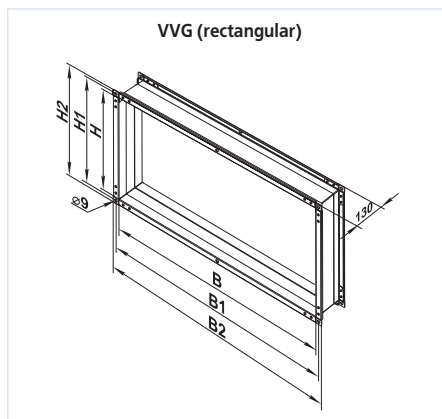

#### Designation key:

Series	Flange diameter, [mm]	Series	Flange designation (WxH) [mm]
VVG VVGF	100; 125; 150; 160; 200; 250; 315; 355; 400; 450; 500	VVG	400x200; 500x250; 500x300; 600x300; 600x350; 700x400; 800x500; 900x500; 1000x500



Series  
**SKRA**



■ **Applications**

Mixing chamber is designed for mixing (recirculation) of a part of the extract air together with the supply air in the ratio required. The recirculation (recuperation of a part of the extract air) provides using a part of warm extract air and its recirculation to the premise.

■ **Design**

The casing is made of galvanized sheet steel. The rotating gear driven blades are made of structural aluminium shape. Two chamber inlets incorporate air

dampers that enable flow-ratio controlling for supply and exhaust recirculated air (0-100%) effected by actuators. SKRA mixing set has two 24V actuators for automatic air flow regulation. Control voltage 0-10 V supplied for the actuator regulates the blades opening and set the flow-ratio control for the supply and recirculated air (0 to 100% recirculation).

■ **Mounting**

Mounting is effected by means of flange connection. Mounting inside the ventilation system is effected by

means of fixing end flanges to the mating flanges of the air ducts or other ventilation system units. Fixing is performed by means of galvanized bolts and clamps. The mixing chambers are designed for indoor or outdoor installation at any operating position. While mounting the space for the access for the actuators shall be provided.

**Overall dimensions:**

Type	Dimensions [mm]								Mass [kg]
	B	B1	B2	B3	H	H1	H2	L	
SKRA 400x200/24	400	420	940	960	200	220	240	390	20
SKRA 500x250/24	500	520	1140	1160	250	270	290	440	25
SKRA 500x300/24	500	520	1140	1160	300	320	340	490	33
SKRA 600x300/24	600	620	1340	1360	300	320	340	490	36
SKRA 600x350/24	600	620	1340	1360	350	370	390	540	40
SKRA 700x400/24	700	720	1540	1560	400	420	440	590	45
SKRA 800x500/24	800	820	1740	1760	500	520	540	690	55
SKRA 900x500/24	900	920	1940	1960	500	520	540	740	60
SKRA 1000x500/24	1000	1020	2140	2160	500	520	540	740	65

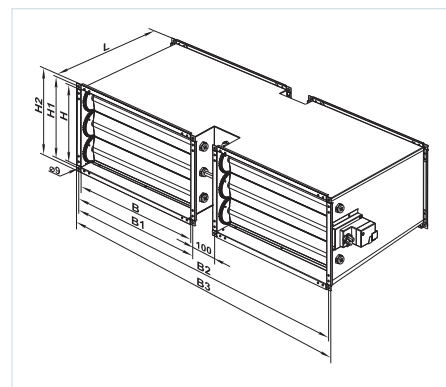

**Designation key:**

Series	Flange designation (WxH) [mm]	Automatic actuator power supply voltage, V
SKRA	400x200; 500x250; 500x300; 600x300; 600x350; 700x400; 800x500; 900x500; 1000x500	24

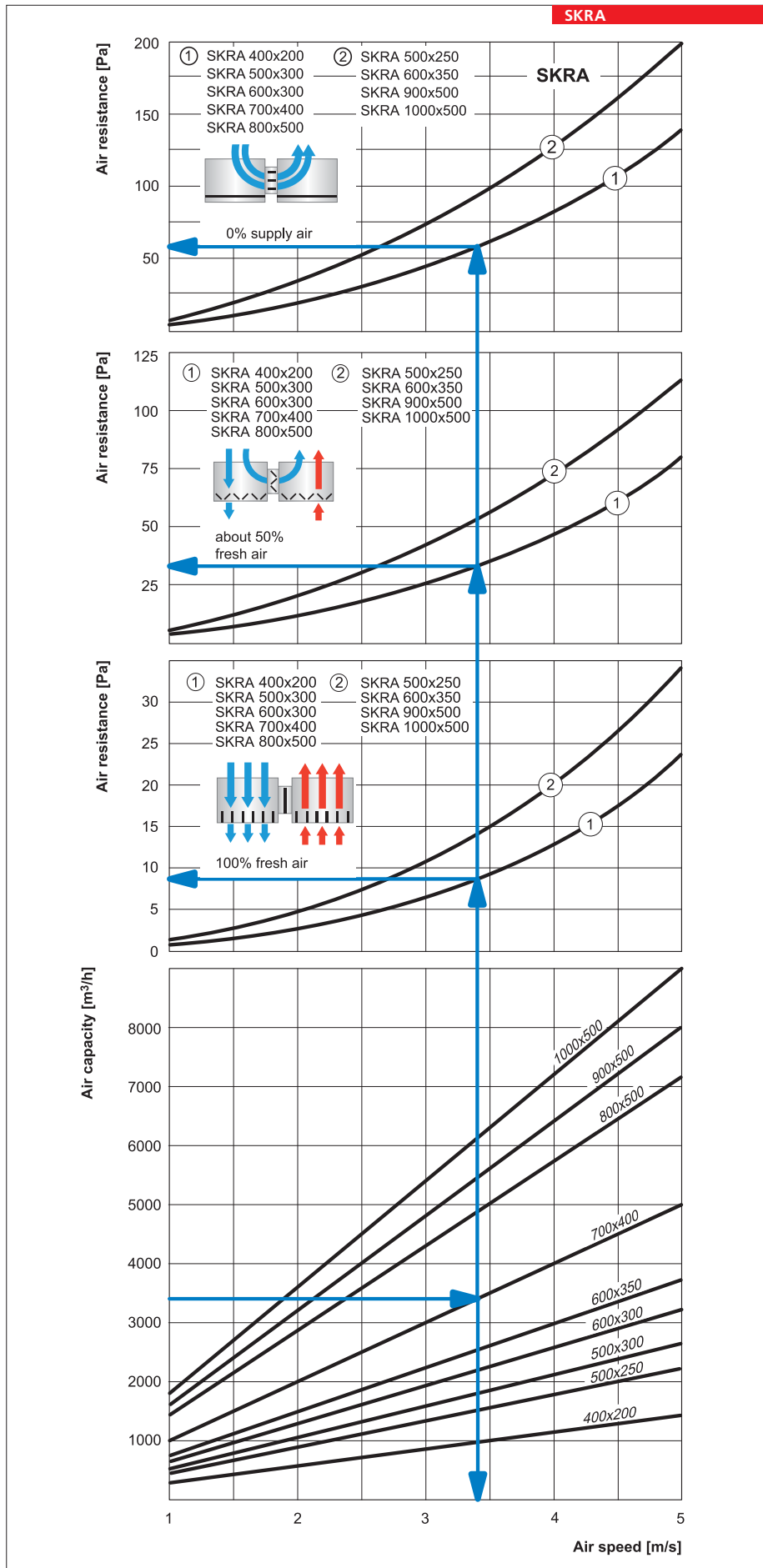

Series  
**CZK**



Series  
**CZ**



■ Applications

Quick-detachable clamp is designed for quick and reliable fixing of various round components of ventilation system.

■ Design

The clamps are made of galvanized steel strip with the layer of microporous rubber for vibration damping. The clamp design allows its wall or cell mounting.

■ Applications

The quick-detachable clamp is designed for quick and reliable mounting and connection of various round components of ventilation system. The clamps facilitate installation and removal of fans for maintenance and cleaning.

■ Design

The clamp is made of galvanized steel strip sealed at one side with microporous rubber for the better airtight characteristics and vibration damping. The quick-detachable clamps are tightened with two bolts.

Overall dimensions:

Type	Dimensions [mm]		Mass [kg]
	∅D	L	
CZK 100	100	204	0,21
CZK 125	125	229	0,22
CZK 150	150	254	0,25
CZK 160	160	264	0,26
CZK 200	200	304	0,31
CZK 250	250	354	0,35
CZK 315	315	419	0,42

Overall dimensions:

Type	Dimensions [mm]		Mass [kg]
	∅D	H	
CZ 100	100	172	0,206
CZ 125	125	198	0,232
CZ 150	150	224	0,296
CZ 160	160	232	0,358
CZ 200	200	274	0,42
CZ 250	250	326	0,55
CZ 315	315	380	0,65

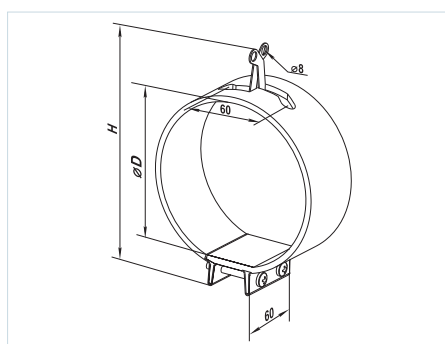
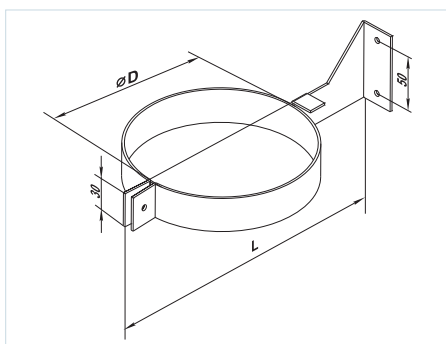

Designation key:

Series	Flange diameter, [mm]
CZK CZ	100; 125; 150; 160; 200; 250; 315

### Series **C**



### Series **CB**



### Series **CBR**



#### ■ Applications

The clamps are designed for quick and reliable mounting and connection of various round ventilation system components. The clamps facilitate the installation and removal of fans for maintenance and cleaning.

#### ■ Design

▶ **C** series clamps are made of stainless steel (C series) or galvanized steel (C.. Z.) strips. The clamps are tightened with screws.

▶ **CB** series clamps are the quick detachable clamps of stainless steel with the swing screw of stainless steel. The clamps are tightened with screw.

▶ **CBR 3000** series clamps are the band clamps in a plastic covering (roll 30 m x 9 mm x 0,8 mm + 50 SU 50 locking devices). Using a band of the worm drive clip of the required length and locking device you have the required diameter clamp. The clamps are tightened with screws.

Tin snips are everything you need to have the required length clamp as the plastic casing has a

special design and marking.

Application:

1. Bend the clamp edge;
2. Fix the bent edge of the band into the band holder;
3. Turn the band holder till the mark of the required diameter on the casing;
4. Cut the band away as applicable for the casing;
5. Fix the locking device on the clamp.

#### Overall dimensions:

Type	Dimensions [mm]	
	∅D	H
C 100	90-110	9
C 125	110-130	9
C 150	140-160	9
C 160	150-170	9
C 200	190-210	9
C 250	240-260	9
C 315	300-330	9

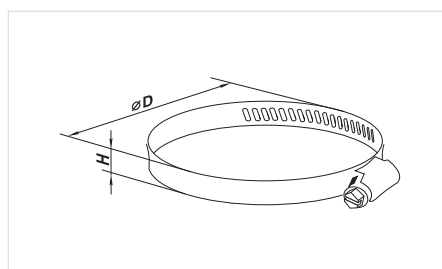
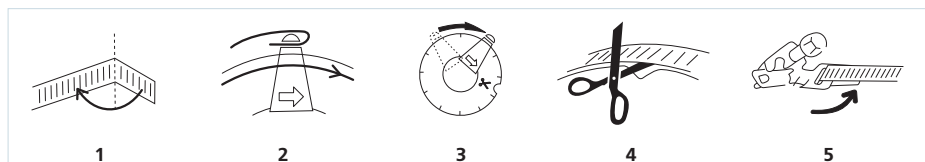

#### Overall dimensions:

Type	Dimensions [mm]	
	∅D	H
CB 60-110	60-110	9
CB 60-135	60-135	9
CB 60-165	60-165	9



#### Designation key:

Series	Diameter, mm
C	100; 125; 150; 160; 200; 250; 315
CB	60-110; 60-135; 60-165
CBR	

CLAMPS  
CZK, CZ,  
C, CB, CBR

# ELECTRICAL ACCESSORIES

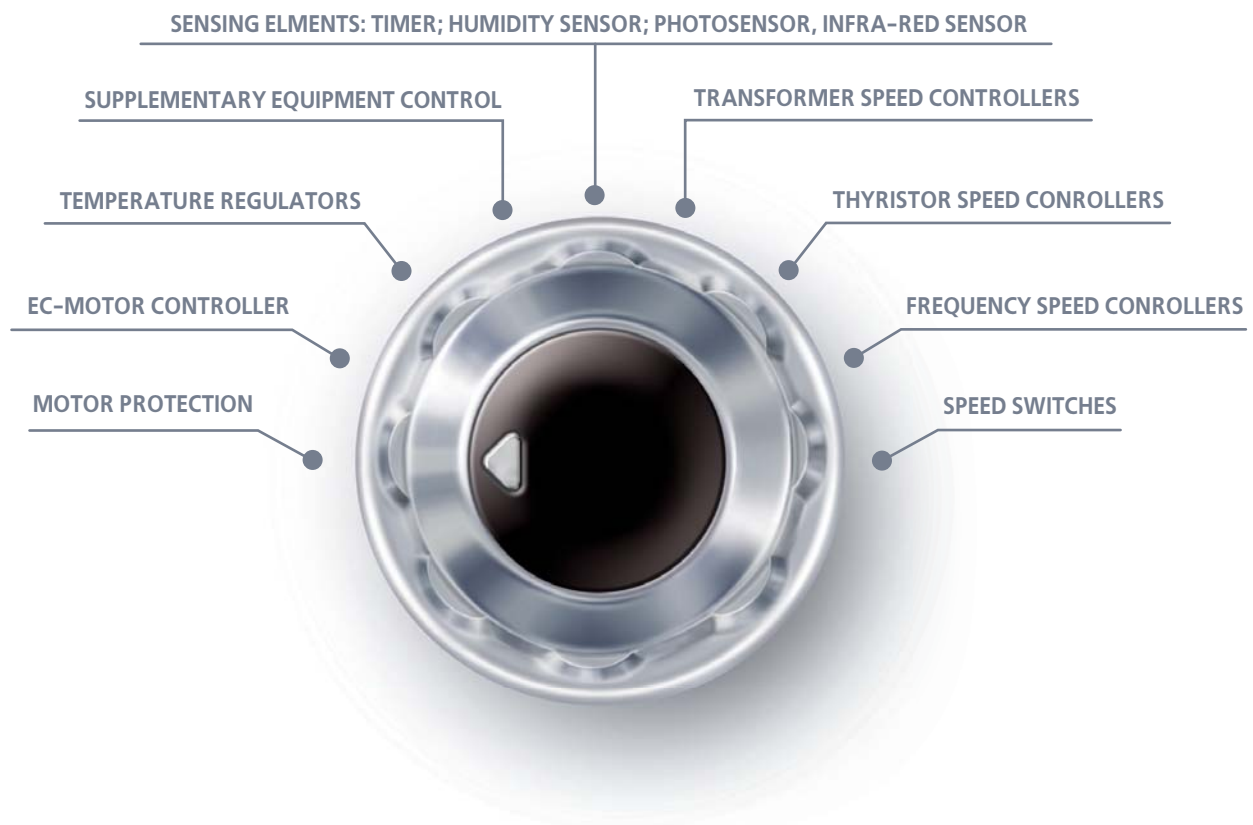



Thyristor speed controller

page  
310



Transformer speed controllers

page  
314



Frequency speed controllers

page  
319



Temperature regulators

page  
320



Speed control switches

page  
322



EC-motors regulators

page  
324



















Sensors

page  
325



## VENTS AUTOMATION FOR FAN CONTROL

Model		Phase	Current	Protection	Casing	Functions
<b>Thyristor speed controller</b>						
RS-1-300		1 phase	up to 1,5 A	IP40	Plastic casing for flush mounting	Smooth fan speed control with built-in switch.
RS-1-400			up to 1,8 A			
RS-1 N (V) RS-1,5 N (V) RS-2 N (V) RS-2,5 N (V)		1 phase	up to 1,0 A up to 1,5 A up to 2,0 A up to 2,5 A	IP44	Plastic casing for flush or surface mounting	Smooth fan speed control with built-in switch.
RS-0,5-PS RS-1,5-PS RS-2,5-PS RS-4,0-PS		1 phase	0,1 - 0,5 A 0,15 - 1,5 A 0,25 - 2,5 A 0,4 - 4,0 A			
RS-1,5-T RS-3,0-T RS-5,0-T RS-10,0-T		1 phase	0,2 - 1,5 A 0,3 - 3,0 A 0,5 - 5,0 A 1,0 - 10,0 A	IP54	Plastic casing for surface mounting	Smooth fan speed control with built-in switch, minimum speed setting.
RS-1,5-TA RS-3,0-TA RS-5,0-TA RS-10,0-TA		1 phase	0,2 - 1,5 A 0,3 - 3,0 A 0,5 - 5,0 A 1,0 - 10,0 A			
<b>transformer speed controllers</b>						
RSA5E-2-P		1 phase	up to 2,0 A	IP54	Plastic casing for surface mounting	Step fan speed control. Overheating motor protection, thermostat and actuator driven air shutoff damper connections. Mechanical speed switching.
RSA5E-2-M RSA5E-3-M RSA5E-4-M RSA5E-12-M		1 phase	up to 2 A up to 3 A up to 4 A up to 12 A			
RSA5E-1,5-T RSA5E-3,5-T RSA5E-5,0-T RSA5E-8,0-T RSA5E-10,0-T		1 phase	up to 1,5 A up to 3,5 A up to 5 A up to 8 A up to 10 A	IP54	Plastic casing for surface mounting	Step fan speed control. Overheating motor protection, thermostat and actuator driven air shutoff damper connections. Mechanical speed switching.
RSA5D-1,5-T RSA5D-3,5-T		3 phase	up to 1,5 A up to 3,5 A			
RSA5D-5-M RSA5D-8-M RSA5D-10-M RSA5D-12-M		3 phase	up to 5 A up to 8 A up to 10 A up to 12,0 A	IP44	Metal casing for surface mounting	Step fan speed control. Overheating motor protection, thermostat and actuator driven air shutoff damper connections. Mechanical speed switching.

Model		Phase	Current	Protection	Casing	Functions
<b>Frequency speed controllers</b>						
VFED-200-TA VFED-400-TA VFED-750-TA VFED-1100-TA VFED-1500-TA		3 phase	200 W / 1A 400 W / 2A 750 W / 3,5 A 1,1 kW / 5,5A 1,5 kW / 7,5 A	IP54	Plastic casing for surface mounting	Smooth speed control of three phase fan. Power supply 220V, motor overheating protection. Control input 0-10 V or 4-20 mA, series port RS232, remote LED display (ordered on request).
<b>Temperature regulators</b>						
RTS -1-400 RTSD -1-400		1 phase	up to 2,0 A	IP40	Plastic casing for flush mounting	Temperature mode control in ventilation, air conditioning and heating systems. Equipped with digital LED display. Automatic heating/cooling rate control.
RT-10		1 phase	up to 10 A	IP40	Plastic casing for surface mounting	Maintaining the set temperature level and control of ventilation, heating and air conditioning systems. Temperature control range from +10 up to +30°C.
<b>Multi-speed fan switches</b>						
P2-5,0 N (V) P3-5,0 N (V) P5-5,0 N (V)		1 phase	up to 5,0 A	IP40	Plastic casing for surface and flush mounting	2 speed step switching 3 speed step switching 5 speed step switching
P2-1-300 P3-1-300		1 phase	up to 5 A	IP40	Plastic casing for flush mounting	2 speed step switching 3 speed step switching
<b>EC-motors controllers</b>						
R-1/010		1 phase	up to 1,1 mA	IP40	Plastic casing for flush mounting	Smooth control of speed, temperature and other characteristics. 0-10V output is equipped with max. 3A built-in switch.
<b>Sensors</b>						
T-1,5N TH-1,5N TF-1,5N TP-1,5N		1 phase	up to 1,5 A	IP54	Plastic casing for surface mounting	Fan operation with running-out timer. Fan humidity-dependent operation. Fan operation with photo-sensor and running-out timer. Fan operation with infra-red sensor and running-out timer.

Speed controller  
**RS-1-300**

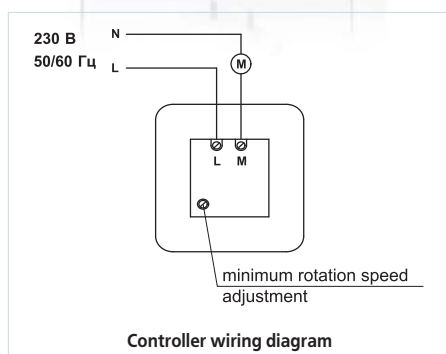

■ **Applications**

Applied in ventilation systems for switching ON/OFF and speed controlling of single-phase power-controlled motors. Several fans can be operated synchronously in case their total consumption current does not exceed the maximum permissible current value.

■ **Design and control**

The controller casing is made of plastic. The controller is featured with high efficiency and control accuracy. Switching to the maximum speed is effected by

means of regulating the control knob. Regulating starts from the minimum to the maximum voltage value for the fan stable running. The minimum speed is set by means of the potentiometer at PCB.

■ **Protection**

The controller incorporates a thermal fuse for motor overload protection.

■ **Mounting**

The controller is designed for indoor mounting into standard round electric junction boxes.

**Technical data:**

	<b>RS-1-300</b>
Voltage, [V/50 Hz]	1~ 230
Rated current, [A]	1,5
Overall dimensions LxWxH [mm]	95x85x60
Maximum ambient temperature [°C]	40
Protection rating	IP 40
Mass [kg]	0,11

Speed controller  
**RS-1-400**

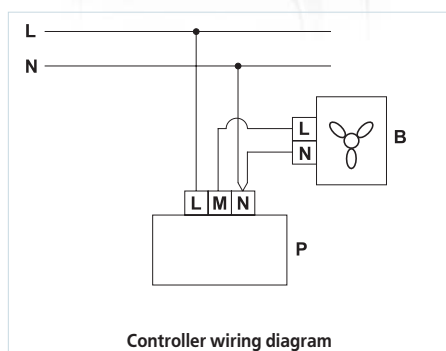

■ **Applications**

Applied in ventilation systems for speed switching ON/OFF and speed control of the single-phase power-controlled motors. Several fans can be controlled synchronously in case their total current does not exceed the maximum permissible values for the controller current.

■ **Design and control**

The controller casing is made of plastic. The controller is featured with high efficiency and control accuracy. Switching to the maximum speed is effected by

means of regulating the control knob. Regulating starts from the minimum to the maximum voltage value for the fan stable running. The minimum speed is set by means of the potentiometer at PCB.

■ **Protection**

The controller incorporate a removable thermal fuse for motor overload protection and transient filter.

■ **Mounting**

The controller is designed for indoor mounting into standard round electric junction boxes.

**Technical data:**

	<b>RS-1-400</b>
Voltage, V/ 50/60 Hz	1~ 230
Rated current, [A]	1,8
Overall dimensions LxWxH [mm]	78x78x63
Maximum ambient temperature [°C]	35
Protection rating	IP 40
Mass [kg]	0,11

## Speed controller RS-...N (V)

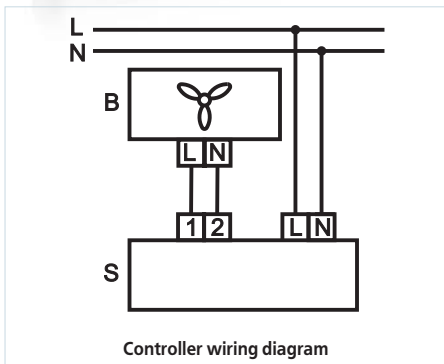

### ■ Applications

Applied in ventilation systems for speed switching ON/OFF and speed control of the single-phase power-controlled motors. Several fans can be controlled synchronously in case their total current does not exceed the maximum permissible values for the controller current.

### ■ Design and control

Controller has the plastic casing with the control knob, ON/OFF button and pilot light. The controller is featured with high efficiency and control accuracy. Regulation starts from the

minimum fan stable running voltage value to the maximum one. The minimum rotation speed is set by means of the potentiometer on the PCB.

### ■ Protection

Input circuit of the speed controller has a thermal fuse for overload protection. The controller is fitted with a transient filter.

### ■ Mounting

The controller is designed for indoor wall mounting either on the wall (H modification) or through the wall (V modification).

### Technical data:

	RS-1 N (V)	RS-1,5N (V)	RS-2 N (V)	RS-2,5N (V)
Voltage, [V/50 Hz]	1~ 230	1~ 230	1~ 230	1~ 230
Rated current, [A]	1,0	1,5	2,0	2,5
Overall dimensions LxWxH [mm]	162x80x70	162x80x70	162x80x70	162x80x70
Maximum ambient temperature [°C]	40	40	40	40
Protection rating	IP 44	IP 44	IP 44	IP 44
Mass [kg]	0,3	0,3	0,3	0,3

## Speed controller RS...PS

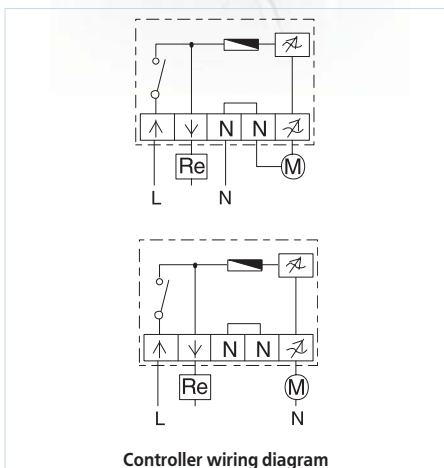

### ■ Applications

Applied in ventilation systems for speed switching ON/OFF and speed control of single-phase power-controlled motors. Several fans can be controlled synchronously in case their total current does not exceed the maximum permissible value of the controller current.

### ■ Design and control

The controller casing is made of plastic. The control knob is equipped with the pilot light. The controller is featured with high efficiency and control accuracy. Switching is effected by means of pressing the control knob. Regulating starts from the minimum to the maximum voltage value for the fan stable running. The minimum speed is

set by means of the potentiometer at the PCB. The controller is equipped with extra 230 V terminal for connection and control of the external equipment.

### ■ Protection

Input circuit of the speed controller has a thermal fuse for overload protection. The controller is fitted with a transient filter.

### ■ Mounting

The universal design of the controller enables its mounting either on the wall (H modification) or through the wall (V modification), suitable for installation into standard round electric junction boxes.

### Technical data:

	RS-0,5-PS	RS-1,5-PS	RS-2,5-PS	RS-4,0-PS
Voltage, V/ 50 Hz	1~ 230	1~ 230	1~ 230	1~ 230
Minimum current [A]	0,1	0,15	0,25	0,4
Maximum current [A]	0,5	1,5	2,5	4,0
Overall dimensions LxWxH [mm]	82x82x65	82x82x65	82x82x65	82x82x65
Maximum ambient temperature [°C]	35	35	35	35
Protection rating	IP 44	IP 44	IP 44	IP 44
Mass [kg]	0,23	0,24	0,29	0,36

RS-1-300  
 RS-1-400  
 RS-...N (V)  
 RS-...PS  
 SPEED CONTROLLERS

Speed controller  
**RS-...-T**



■ **Applications**

Applied in ventilation systems for speed switching ON/OFF and speed control of single-phase power-controlled motors. Several fans can be controlled synchronously in case their total consumption current does not exceed the maximum permissible value of the controller current.

■ **Design and control**

The controller casing is made of flame-retardant thermoplastic and fitted with ON/OFF knob with pilot light. The controller is featured with high efficiency and control accuracy. Output power is controlled from 25 to 100% as a function of the control knob position. The minimum speed is set by means of the potentiometer at the PCB. The controller is

equipped with extra 230 V terminal for connection and controlling such external equipment as actuator-driven air dampers.

■ **Protection**

Input circuit of the speed controller has a thermal fuse for overload protection. The controller is fitted with a transient filter.

■ **Mounting**

The controller is designed for indoor mounting. Installation shall be performed with respect to the free air circulation for inner circuit cooling. The controller is for vertical installation. Do not install the controller above the heaters and in bad air convection areas.

**Technical data:**

	RS-1,5-T	RS-3,0-T	RS-5,0-T	RS-10,0-T
Voltage, [V/50 Hz]	1~ 230	1~ 230	1~ 230	1~ 230
Minimum current [A]	0,2	0,3	0,5	1,0
Maximum current [A]	1,5	3,0	5,0	10,0
Overall dimensions LxWxH [mm]	123x191x97	123x191x97	123x191x97	123x191x97
Maximum ambient temperature [°C]	+5...+40	+5...+40	+5...+40	+5...+40
Protection rating	IP 54	IP 54	IP 54	IP 54
Mass [kg]	0,3	0,3	0,3	0,3

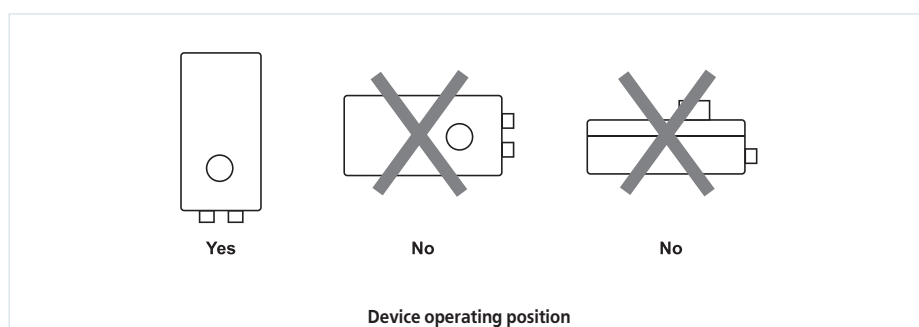
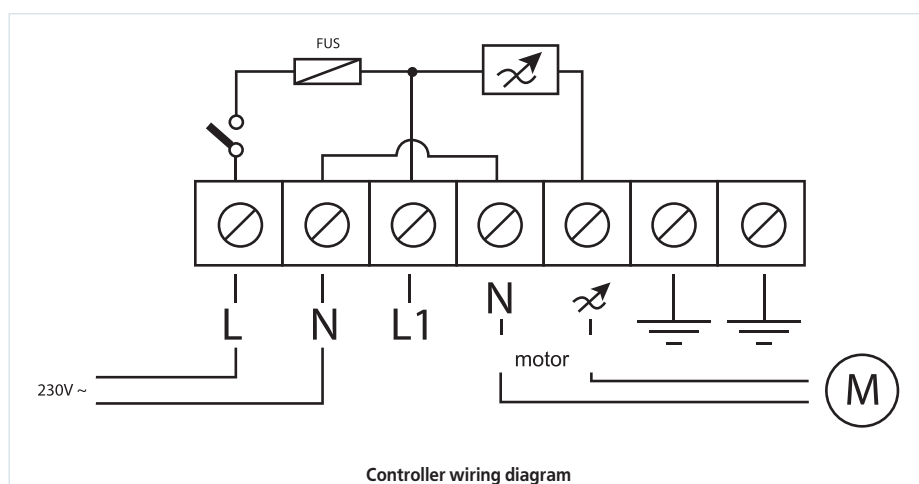

## Speed controller RS-...-TA



### ■ Applications

Applied in ventilation systems for switching ON/OFF and speed controlling of single-phase power-controlled motors. Several fans can be operated synchronously in case their total consumption current does not exceed the maximum permissible value of the controller current.

### ■ Design and control

The controller casing is made of flame-retardant thermoplastic and fitted with ON/OFF knob. Output power is controlled from 25 to 100% as a function of the control signal 0...10V or 4-20mA over the range set during the controller adjustment. The control signal type 0...10V or 4-20mA is selected with SW2 control switch located in the controller casing. Control can be performed by means of remote control panel, i.e., R-1/010

controller (page 324). The minimum speed is set by means of the potentiometer at PCB inside the controller. The controller is equipped with a supplementary 230V terminal for connection and control of such external equipment as actuator driven air dampers.

### ■ Protection

Input circuit of the speed controller has a thermal fuse for overload protection.

### ■ Mounting

The controller is designed for indoor mounting. Installation shall be performed with respect to the free air circulation for inner circuit cooling. The controller is for vertical installation. Do not install the controller above the heaters and in bad air convection areas.

### Technical data:

	RS-1,5-TA	RS-3,0-TA	RS-5,0-TA	RS-10,0-TA
Voltage, [V/50 Hz]	1~ 230	1~ 230	1~ 230	1~ 230
Minimum current [A]	0,2	0,3	0,5	1,0
Maximum current [A]	1,5	3,0	5,0	10,0
Overall dimensions LxWxH [mm]	180x127x95	180x127x95	180x127x95	180x127x95
Maximum ambient temperature [°C]	+5...+40	+5...+40	+5...+40	+5...+40
Protection rating	IP 54	IP 54	IP 54	IP 54
Mass [kg]	0,3	0,3	0,3	0,3

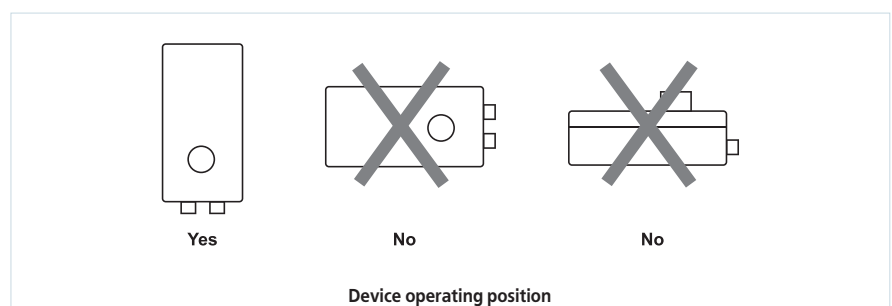
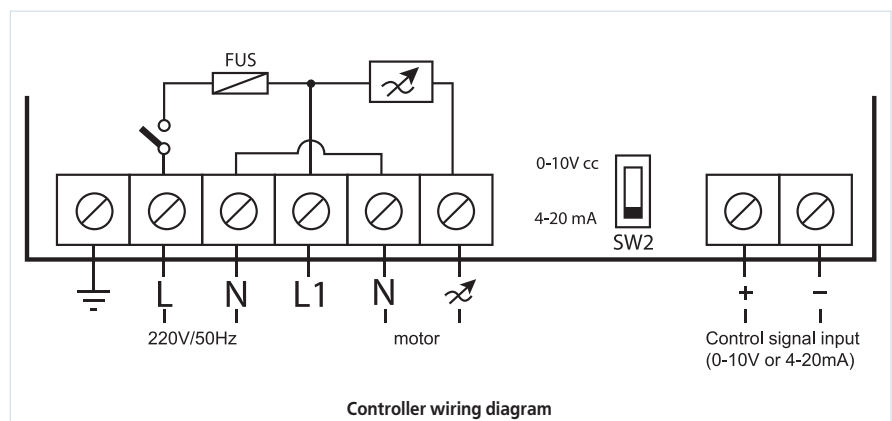



Single-phase speed controller  
**RSA5E-2-P**



Speed control enables not only selecting the comfortable ventilation mode for the periodically visited premises but reducing the energy consumption for the ventilation.

■ **Applications**

RSA5E-2-P series speed controller is applied for air capacity control of single-phase fans by means of step control of motor speed. The controller has five speeds. Speed is set by means of rotating the control knob at the casing front panel. Several fans can be controlled synchronously in case their total consumption current does not exceed the maximum permissible value of the controller current.

■ **Design**

The controller casing is made of flame-retardant thermoplastic. The controller has five speeds with the output power 110V-130V-160V-190V-230V and incorporates ON/OFF button with pilot light, the control knob for speed switching and the emergency operation LED indicator. The integral motor protection device is included which cuts the supply voltage to the fan if the thermal contact in the fan

motor is activated. After the temperature drops to the operating level the motor restarts.

The controller has the following supplementary functions:

- terminals for connection to the room thermostat or to the thermostat for the icing protection. In case of the circuit breaking the power supply to the motor is disabled.
- terminals of 230 V, max. 2A for connection and controlling such external equipment actuator driven air damper.
- provision for remote speed control (refer the connection options).

■ **Mounting**

The controller is designed for indoor mounting. Installation shall be performed with respect to the free air recirculation for inner circuit cooling.

**Technical data:**

	<b>RSA5E-2-P</b>
Voltage, [V/50 Hz]	1~ 230
Rated current, [A]	2,0
Overall dimensions LxWxH [mm]	222x120x100
Maximum ambient temperature [°C]	40
Protection rating	IP 54
Mass [kg]	3,1

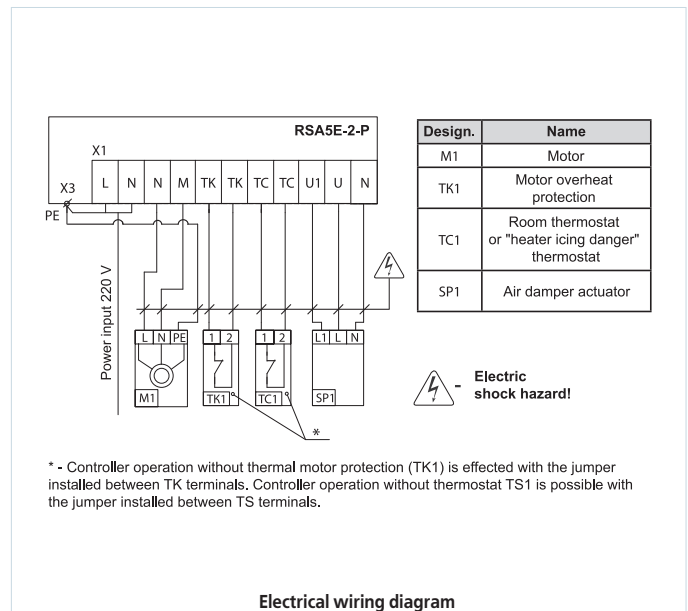
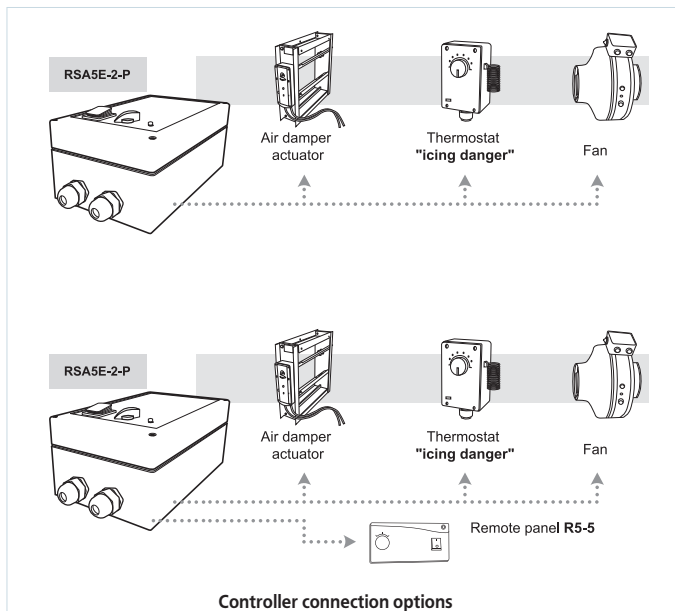

\* - Controller operation without thermal motor protection (TK1) is effected with the jumper installed between TK terminals. Controller operation without thermostat TS1 is possible with the jumper installed between TS terminals.

## Single phase speed controller RSA5E-...-M



Speed controls enables not only selecting the comfortable ventilation mode for the periodically visited premises but reducing the energy consumption for the ventilation.

### ■ Applications

RSA5E-...-M series speed controllers are applied for air capacity control of single-phase fans by means of step speed control. The controller has five speeds. Speed is set by means of rotating the control knob at the casing front panel. Several fans can be controlled synchronously in case their total consumption current does not exceed the maximum permissible value of the controller current.

### ■ Design and control

Casing is made of steel with polymeric coating. The controller has five speeds with the output power 110V-130V-160V-190V-230V (for RSA5E-12-M modification-80V-105V-130V-160V-230V). The controller incorporates ON/OFF button with pilot light, control knob for speed switching and controller emergency operation LED indicator.

### ■ Protection

The integral motor protection device is included which cuts the supply voltage to the fan if the thermal contact in the fan motor is activated. After the temperature drops to the operating level the motor restarts.

The controller has the following supplementary functions:

- terminals for connection to the room thermostat or to the icing protection thermostat. In case of the circuit breaking the power supply to the motor is cut.
- terminals of 230 V, max. 2A/3A/4A for connection and controlling such external equipment as actuator driven air damper.
- provision for remote speed control (refer the connection options).

### ■ Mounting

The controller is designed for indoor mounting. Installation shall be performed with respect to the free air circulation for inner circuit cooling.

### Technical data:

	RSA5E-2-M	RSA5E-3-M	RSA5E-4-M	RSA5E-12-M
Voltage, [V/50 Hz]	1~ 230	1~ 230	1~ 230	1~ 230
Rated current, [A]	2,0	3,0	4,0	12,0
Overall dimensions LxWxH [mm]	226x144x120	241x164x138	241x184x132	325x250x245
Maximum ambient temperature [°C]	40	40	40	40
Protection rating	IP 21	IP 21	IP 21	IP 44
Mass [kg]	3,4	4,1	4,5	4,5

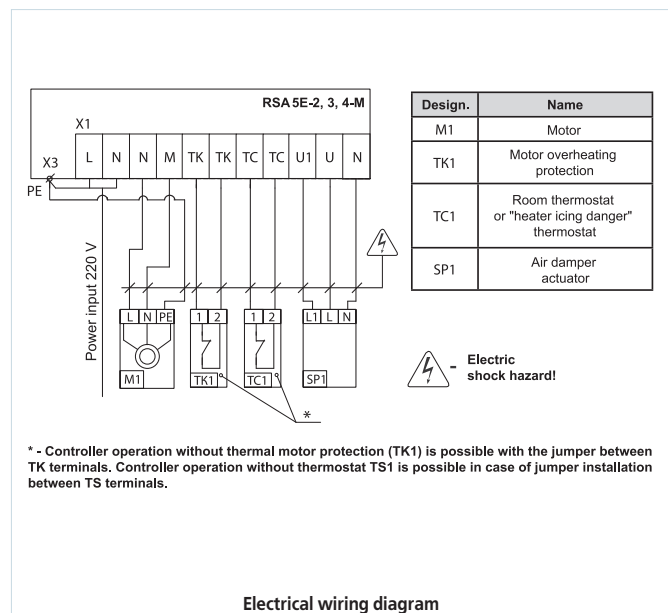
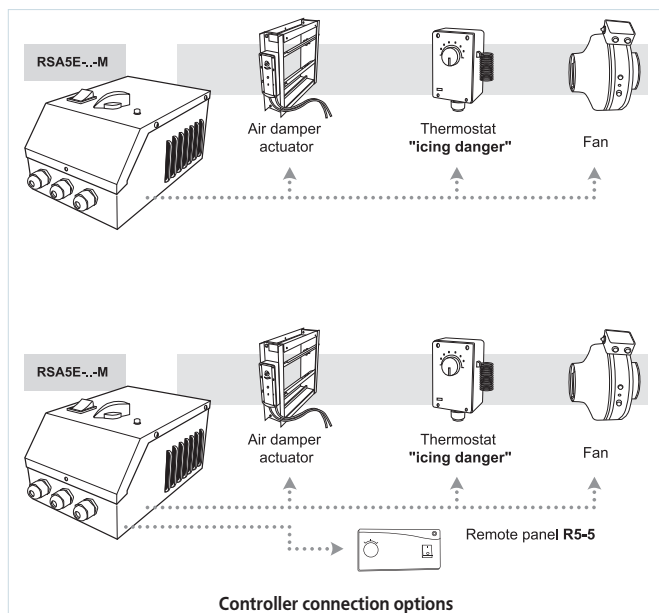

Single phase speed controller  
**RSA5E-...-T**



■ **Applications**

RSA5E-...T series speed controllers are applied for air capacity control of single-phase fans by means of motor step speed control. The controllers have five speeds. Speed is set by means of rotating the control knob at the casing front panel to one of five available fixed positions. Several fans can be controlled synchronously in case their total consumption current does not exceed the maximum permissible value of the controller current.

■ **Design and control**

The controller casing is made of flame-retardant thermoplastic. The controller has five speeds with the output power 80V - 105V - 130V - 160V - 230V and incorporates ON/OFF pilot light for operation indication, control knob for speed switching and controller emergency operation LED indicator. The

integral motor protection device is included which cuts the supply voltage to the fan if the thermal contact in the fan motor is activated. After the temperature drops to the operating level the motor restarts.

The controller has the following supplementary functions:

- terminals of 230 V, max. 2A for connection and controlling such external equipment as actuator driven air dampers.

■ **Mounting**

The controller is designed for indoor mounting. Installation shall be performed with respect to the free air recirculation for inner circuit cooling. The controller is for vertical installation. Do not install the controller above the heaters and in bad air convection areas.

**Technical data:**

	<b>RSA5E-1,5-T</b>	<b>RSA5E-3,5-T</b>	<b>RSA5E-5,0-T</b>	<b>RSA5E-8,0-T</b>	<b>RSA5E-10,0-T</b>
Voltage [V/50 Hz]	1~ 230	1~ 230	1~ 230	1~ 230	1~ 230
Rated current, [A]	1,5	3,5	5,0	8,0	10,0
Overall dimensions LxWxH [mm]	205x110x85	255x170x140	255x170x140	305x200x180	305x200x180
Maximum ambient temperature [°C]	+5...+35	+5...+35	+5...+35	+5...+35	+5...+35
Protection rating	IP 44	IP 44	IP 44	IP 44	IP 44

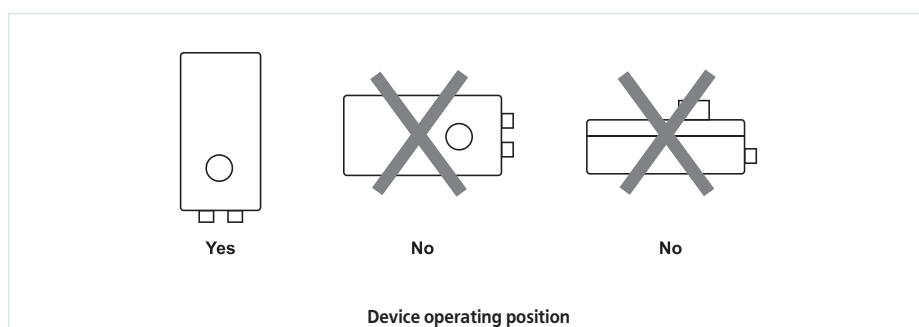
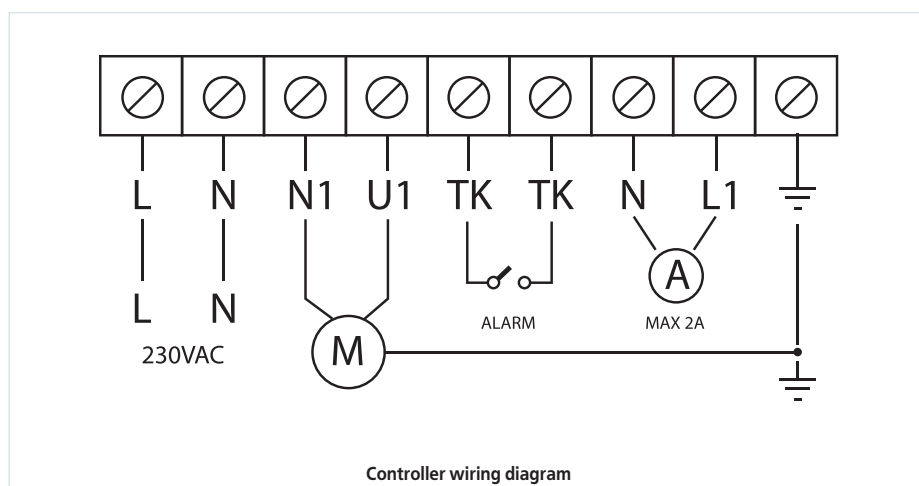

### Three-phase speed controller **RSA5D-...-T**



**Applications**

RSA5D-...T series speed controllers are applied for air capacity control of three-phase fans by means of step speed control. The controllers have five speeds. Speed is set by means of rotating the control knob at the casing front panel to one of five available fixed positions. Several fans can be controlled synchronously in case their total consumption current does not exceed the maximum permissible value of the controller current.

**Design and control**

The controller casing is made of flame-retardant thermoplastic. The controller has five speeds with the output power 90V - 150V - 200V - 280V - 400V and incorporates control speed knob, pilot light and controller emergency operation LED indicator.

The integral motor protection device is included which cuts the supply voltage to the fan if the thermal contact in the fan motor is activated. After the temperature drops to the operating level the motor restarts.

As supplementary functions the controller is fitted with terminals of 230 V, max. 2A for connection and controlling such external equipment as actuator driven air damper.

**Mounting**

The controller is designed for indoor mounting. Installation shall be performed with respect to the free air recirculation for inner circuit cooling. The controller is for vertical installation. Do not install the controller above the heaters and in bad air convection areas.

**Technical data:**

	<b>RSA5D-1,5-T</b>	<b>RSA5D-3,5-T</b>
Voltage, [V/ 50 Hz]	3~ 400	3~ 400
Rated current, [A]	1,5	3,5
Overall dimensions LxWxH [mm]	305x200x180	305x200x180
Maximum ambient temperature [°C]	+5...+35	+5...+35
Protection rating	IP 44	IP 44

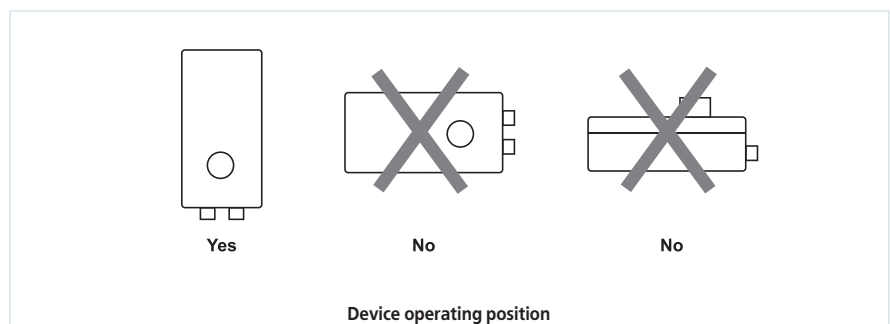
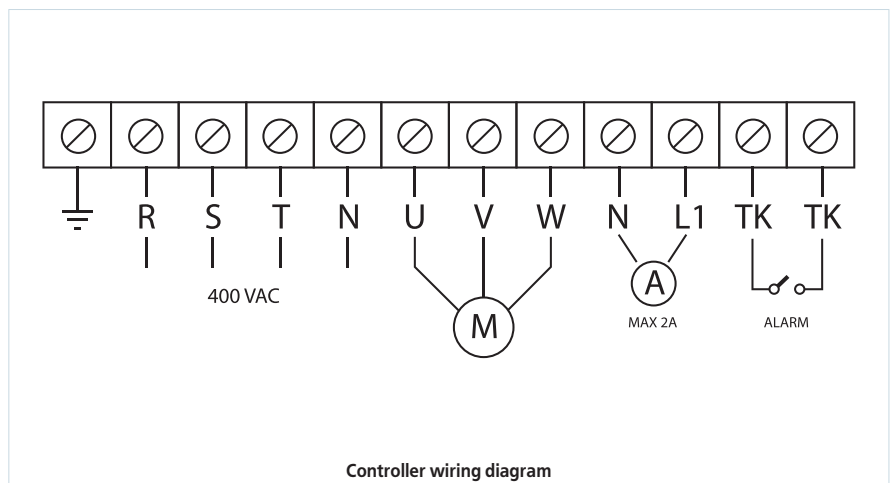

SPEED CONTROLLERS  
RSA5E-...-T  
RSA5D-...-T

Three-phase speed controller  
**RSA5D-...-M**



■ **Applications**

RSA5D-...M series speed controllers are applied for air capacity control of three-phase fans by means of step control of motor speed. The controllers have five speeds. Speed is set by means of rotating the control knob at the casing front panel to one of five available fixed positions. Several fans can be controlled synchronously in case their total consumption current does not exceed the maximum permissible value of the controller current.

■ **Design and control**

The controller casing is made of flame-retardant thermoplastic. The controller has five speeds with the output power 90V - 150V - 200V - 280V - 400V and incorporates control speed knob, light indication for operation and pilot lamp to indicate the emergency

operation of the controller. The controller has built-in motor overheating protection which cuts power supply in case of exceeding the set temperature threshold. After the temperature drops to the operating level the motor restarts.

The controller is fitted with terminals of 230 V, max. 2A for connection and controlling such external equipment as actuator driven air damper.

■ **Mounting**

The controller is designed for indoor mounting. Installation shall be performed with respect to the free air recirculation for inner circuit cooling. The controller is for vertical installation. Do not install the controller above the heaters and in bad air convection areas.

**Technical data:**

	<b>RSA5D-5,0-M</b>	<b>RSA5D-8,0-M</b>	<b>RSA5D-10,0-M</b>	<b>RSA5D-12,0-M</b>
Voltage, [V/ 50 Hz]	3~ 400	3~ 400	3~ 400	3~ 400
Rated current, [A]	5,0	8,0	10,0	12,0
Overall dimensions LxWxH [mm]	325x250x245	325x250x245	425x300x250	425x300x250
Maximum ambient temperature [°C]	+5...+35	+5...+35	+5...+35	+5...+35
Protection rating	IP 44	IP 44	IP 44	IP 44

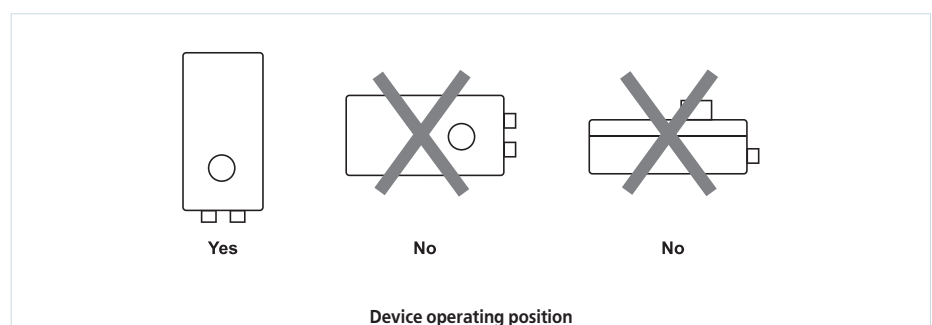
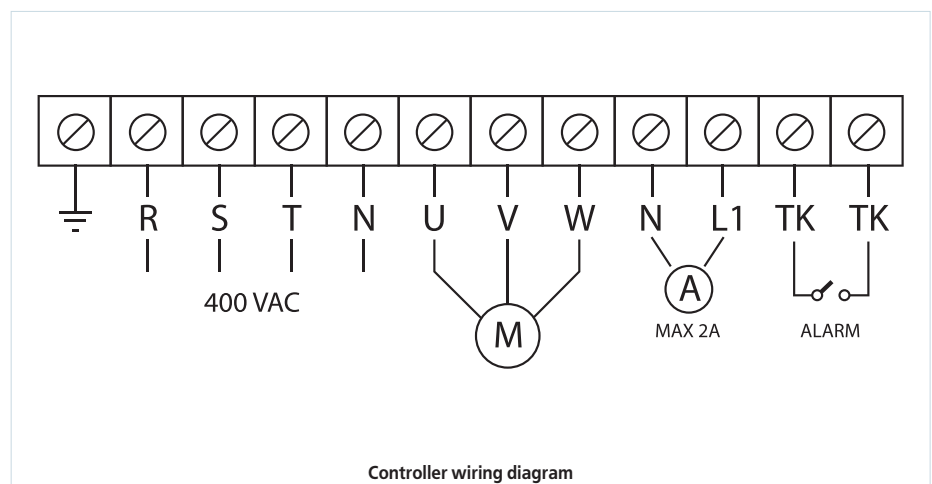

**FREQUENCY SPEED CONTROLLER**

**Frequency speed controller  
VFED-...-TA**



Frequency speed controllers are the energy saving devices which ensure maximum utilization of actuator power with minimum energy consumption.

**Applications**

VFED-...-TA series controllers or inverters are designed for frequency control of three-phase asynchronous AC motors. Speed control is effected by means of variation of supplied voltage frequency. Applied for air capacity control of three-phase motors.

**Design and control**

The controller casing is made of flame-retardant thermoplastic. The assembly transforms voltage of 220V, 50Hz supply mains into output impulse voltage with the frequency 3Hz to 400 Hz. Motor rotor is powered with simple sinusoidal current and has the rotation speed as a function of the supplied

voltage frequency. Single-phase 220V, 50Hz power is supplied to the frequency controller inlet. Three-phase voltage with the frequency up to 400 Hz for asynchronous motor supply is generated at the controller outlet.

**Control by means of external device**

Power output variation as a function of the external control signal 0..10V or 4-20mA over the range set during the controller adjustment. The external device is connected through RS-232 serial port.

**Mounting**

The controller is designed for indoor mounting. Installation shall be performed with respect to the free air circulation for inner circuit cooling. The controller is for vertical installation. Do not install the controller above the heaters and in bad air convection areas.

**Technical data:**

	VFED-200-TA	VFED-400-TA	VFED-750-TA	VFED-1100-TA	VFED-1500-TA
Voltage supplied to the controller [V/50 Hz]	1~ 230	1~ 230	1~ 230	1~ 230	1~ 230
Voltage supplied from the controller to the electric motor, [V]	3~ 230	3~ 230	3~ 230	3~ 230	3~ 230
Frequency output supplied to the motor, [Hz]	from 3 to 400	from 3 to 400	from 3 to 400	from 3 to 400	from 3 to 400
Maximum load current [A]	1,0	2,0	3,5	5,5	7,5
Maximum electric motor power [W]	200	400	750	1100	1500
Maximum ambient temperature [°C]	+5...+40	+5...+40	+5...+40	+5...+40	+5...+40
Protection rating	IP 54	IP 54	IP 54	IP 54	IP 54

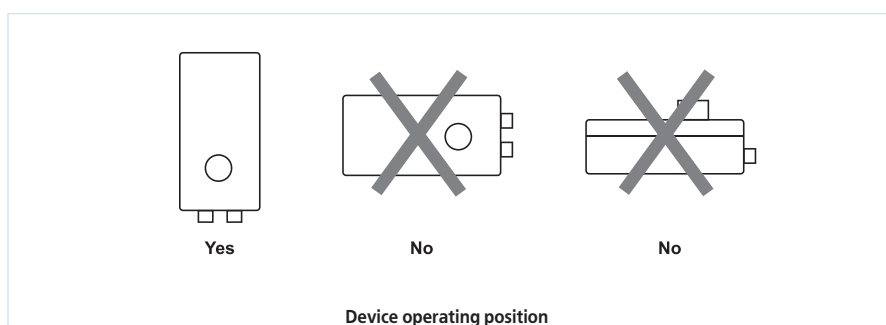
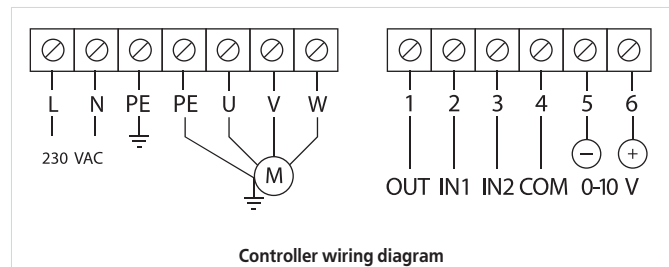
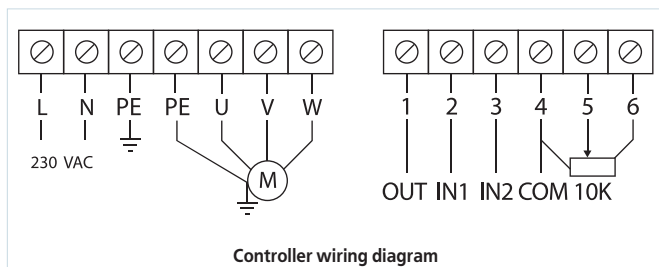



Temperature regulator  
**RTS -1- 400**  
**RTSD -1- 400**



■ **Applications**

Applied for temperature mode control in ventilation, heating and air conditioning systems. Can be applied for control of fans and fancoil valves, air heating units with 230V three speed fans. Automatic heating or cooling rate control.

■ **Design and control**

The temperature sensor is built into the plastic control panel casing. A digital light-up LCD display and control knobs are located at the control face panel. The display shows the current and set indoor air temperature, selected mode for cooling, heating or automatic mode as well as set motor speed. The rotation speed can be adjusted manually by means of control knob rotation. Provision is made for

automatic control of rotation speed (quick/medium/low) depending on the indoor temperature.

- The light-up display enables the regulator operation in bad light conditions
- Temperature maintaining within up to 1°C.
- saving settings at no power supply.
- RTSD-1-400 model is equipped with remote control panel.
- night duty operation (refer to operation mode for night duty below).

■ **Mounting**

Control panel is designed for indoor surface mounting. The recommended installation height is 1.5 m. Do not install the control panel close to windows, doors, heating or cooling devices.

**Technical data:**

	<b>RTS-1-400</b>	<b>RTSD-1-400</b>
Voltage, V/ 50 Hz	1~ 230	1~ 230
Rated current, [A]	2,0	2,0
Number of selected speeds	3	3
Temperature adjustment range [°C]	+10...+30	+10...+30
Overall dimensions LxWxH [mm]	88x88x51	88x88x51
Maximum ambient temperature [°C]	40	40
Protection rating	IP 40	IP 40
Remote control panel	no	yes

**Controller connection options**

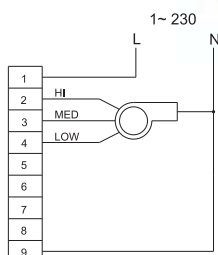

Ventilation with heating and cooling

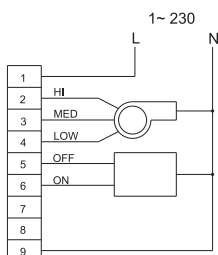

Ventilation with heating and cooling three-wire system of SPDT valves

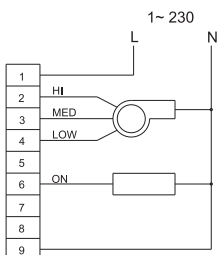

Ventilation with heating and cooling two-wire system of SPST valves

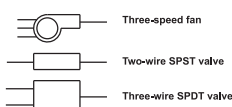

**NIGHT DUTY OPERATION peculiarities**

▶ **Operation of the temperature regulator in the heating mode:** in 30 minutes after switching to the night duty the indoor temperature goes automatically down by 1°C and in 1 hour the temperature goes down by 1°C more. One hour later the temperature goes down by 1°C more and will be kept at this level within 8 hours. After switching the timer off the temperature will be reset to the reference set level automatically.

▶ **Operation of the temperature regulator in cooling mode:** in 30 minutes after switching to the night duty the indoor temperature goes automatically up by 1°C and in 1 hour the temperature goes up by 1°C more and will be kept at that level up to 8 hours. After switching the timer off the temperature will be reset to the reference level automatically.

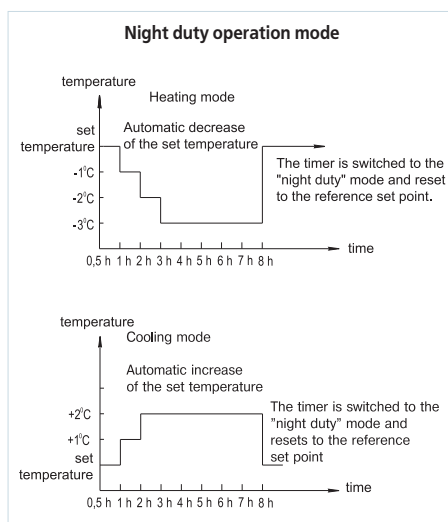

## Temperature regulator RT-10



### ■ Applications

Applied for control of the set indoor temperature as well as ventilation and air conditioning systems control.

### ■ Design and control

The casing is made of high-quality durable plastic. During the temperature increase or decrease with respect to the set value the thermostat opens or closes the contacts (the pattern is selected during

the connection. The temperature adjustment range is +10 up to +30°C.

### ■ Mounting

The temperature regulator is designed for indoor surface mounting. The recommended installation height is 1.5 m. Do not install the temperature regulator close to windows, doors, heating or cooling devices.

### Technical data:

	RT-10
Voltage [V/50/60 Hz]	1~ 220-240
Overall dimensions LxWxH [mm]	84x84x35
Maximum ambient temperature [°C]	40
Protection rating	IP 40

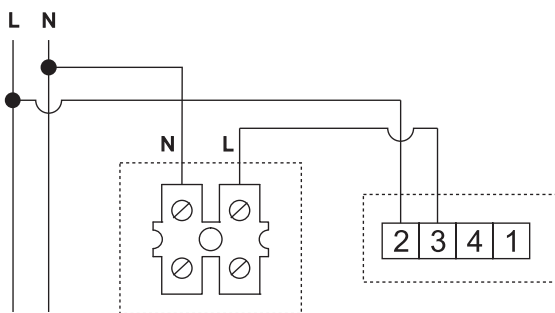

The fan operates till reaching the temperature threshold level set in the temperature regulator

fig. 1

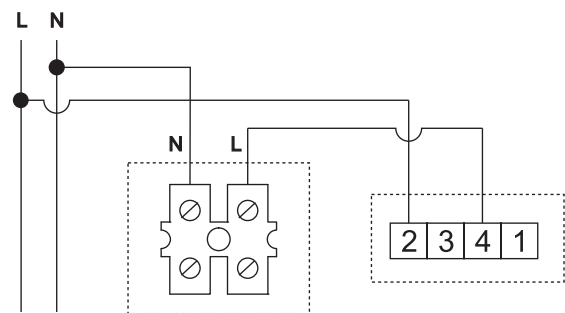

The fan starts operation after reaching the temperature threshold set in the temperature regulator

fig. 2

### Temperature regulator connection options

#### Wiring diagram, fig. 1

- maximum current of active load no more 10A;
- maximum current of inductive load no more 3A.

#### Wiring diagram, fig. 2

- maximum current of active load no more 6A;
- maximum current of inductive load no more 2A.

Switch  
**P2-5,0 N(V)**  
**P3-5,0 N(V)**  
**P5-5,0 N(V)**



■ **Applications**

Applied for speed ON/OFF switching and speed selection in the fans with multi-speed motors.

means of the remote panel for speed switching for multistage transformer speed controller as P5-5,0 for five-stage transformer speed controller.

■ **Design and control**

The switch casing is made of plastic and fitted with ON/OFF knob with operating mode indicator light. The fan speeds can be switched directly or by

■ **Mounting**

The universal design of the controller enables its indoor wall mounting either on the wall (H modification) or through the wall (V modification).

**Technical data:**

	<b>P2-5,0</b>	<b>P3-5,0</b>	<b>P5-5,0</b>
Voltage, [V/ 50 Hz]	1~ 230	1~ 230	1~ 230
Rated current, [A]	5,0	5,0	5,0
Number of selected speeds	2	3	5
Overall dimensions LxWxH [mm]	88x88x51	88x88x51	88x88x51
Maximum ambient temperature [°C]	40	40	40
Protection rating	IP 40	IP 40	IP 40
Mass [kg]	0,25	0,25	0,25

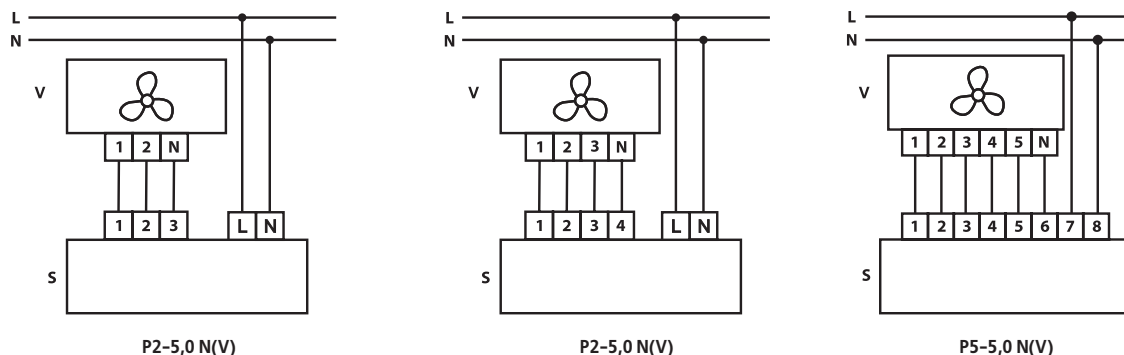

V - fan;  
 S - switch

P2-5,0 N(V)

P3-5,0 N(V)

P5-5,0 N(V)

Switch connection options

Switch  
**P2-1-300**  
**P3-1-300**



■ **Applications**

Applied for speed ON/OFF switching and speed select switching in the fans with multi-speed motors.

■ **Design and control**

The casing is made of plastic. Provision is made for the direct switching of the motor speeds (wiring

diagram 1 and 3) as well as fan switching ON and control synchronically with lightening in the room (wiring diagram 2 and 4).

■ **Mounting**

Speed switch is designed for indoor wall mounting inside a flush mounting box. It can be installed into standard round electric junction boxes.

**Technical data:**

	<b>P2-1-300</b>	<b>P3-1-300</b>
Voltage, V/ 50 Hz	1~ 230	1~ 230
Rated current, [A]	5,0	5,0
Number of selected speeds	2	3
Overall dimensions LxWxH [mm]	88x88x51	88x88x51
Maximum ambient temperature [°C]	40	40
Protection rating	IP 40	IP 40
Mass [kg]	0,13	0,13

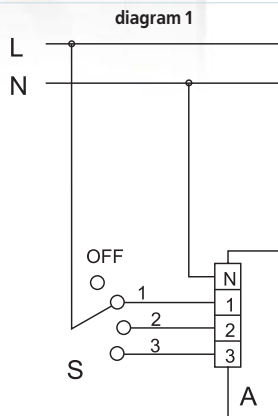

The fan can be manually switched ON to one of the three required speeds or switched OFF by means of external speed switch as P3-1-300.

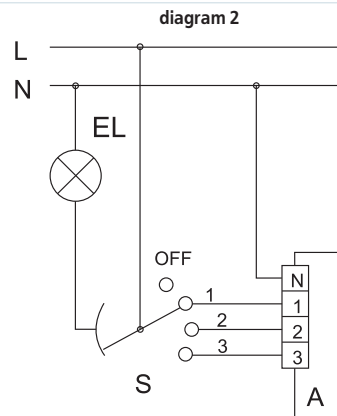

The fan can be manually switched ON to one of three speeds by means of such external S speed switch as P3-1-300. When switching the fan ON the light is switched in parallel ON. The fan can be switched OFF with parallel switching the light OFF. The fan operates both with light or without it.

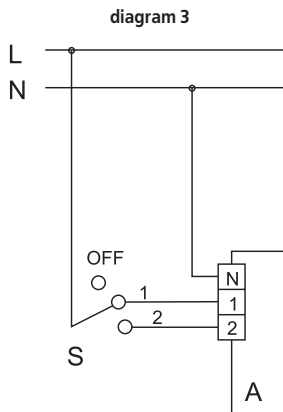

The fan can be manually switched ON to one of the two required speeds or switched OFF by means of the external speed switch as P2-1-300.

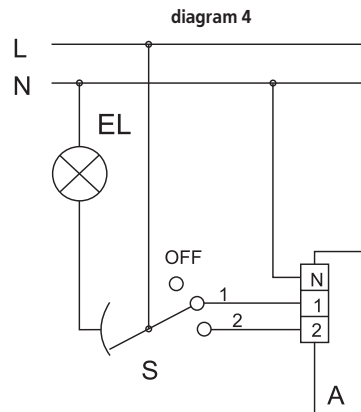

The fan can be manually switched ON to one of three speeds by means of the external S speed switch as P2-1-300. When switching the fan ON the light is switched in parallel ON. The fan can be switched OFF with parallel switching the light OFF. The fan operates both with light or without it.

Switch connection options

Speed controller  
**R-1/010**



■ **Applications**

Applied for smooth speed control of EC motors with the control input 0-10 V.

■ **Design and control**

The controller casing is made of plastic. Switching ON/OFF is effected by means of control knob rotation.

The control range starts from the minimum possible value and includes the maximum possible values.

■ **Mounting**

The speed controller is designed for indoor flush mounting box. It can be also installed into standard round electric junction boxes.

**Technical data:**

	<b>R-1/010</b>
Voltage [V]	10-48VDC
Control signal [V]	0-10
Maximum current [mA]	5mA
Overall dimensions LxWxH [mm]	78x78x63
Maximum ambient temperature [°C]	35
Protection rating	IP 40
Mass [kg]	0,12

Designation key:  
V - fan;  
R - controller R-1/010

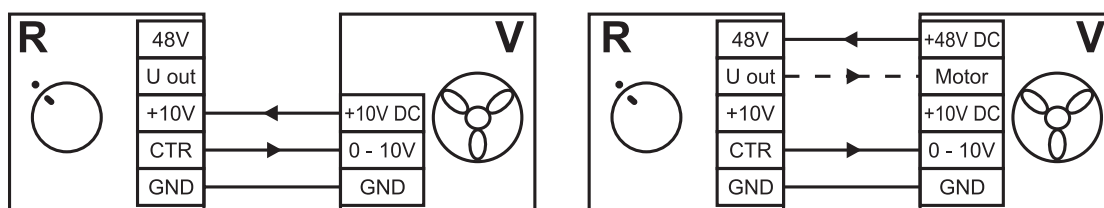

Controller wiring diagram

Time sensor  
**T-1,5 N**  
**TH-1,5 N**  
**TF-1,5 N**  
**TP-1,5 N**



■ **T-1,5 N - run out timer**

Enables the fan operation within the set time period after pressing the knob for switching the fan OFF. After the set time from 2 to 30 minutes the fan switches automatically OFF. The run-out timer is generally applicable for the fans installed in bathrooms, WC or kitchens.

■ **TH-1,5 N - humidity sensor**

The fan with such sensor switches automatically ON in case of exceeding the set humidity level. A user can independently adjust the required humidity level based on personal preferences. The humidity sensor is generally applicable for the fans installed in the premises with increased humidity as bathrooms, kitchens, washing rooms or pools.

■ **TF-1,5 N - timer + photo sensor**

The built-in photo sensor responds to the indoor illumination rate fluctuations and has the provisions for automatic switching the fan ON accordingly. In case of light switching OFF the fan will be switched

OFF with respect to the built-in run-out timer with the time period set between 2 to 30 minutes. In such a way the ventilation system fitted with a photo sensor is fully automated and requires no human control. The photo sensor is generally applicable for the fans installed in periodically visited premises.

■ **TP-1,5 N - infra-red sensor**

The built-in infra-red sensor responds to movement in a room and switches the fan automatically ON. If the room is empty the fan switches OFF with respect to the built-in run-out timer adjustable between 2 to 30 minutes. In such a way the ventilation system fitted with infra-red sensor is fully automated and requires no human control. The infra-red sensor is generally applicable for the fans installed in periodically occupied spaces.

■ **Mounting**

The sensors are designed for indoor wall surface installation (Modification N).

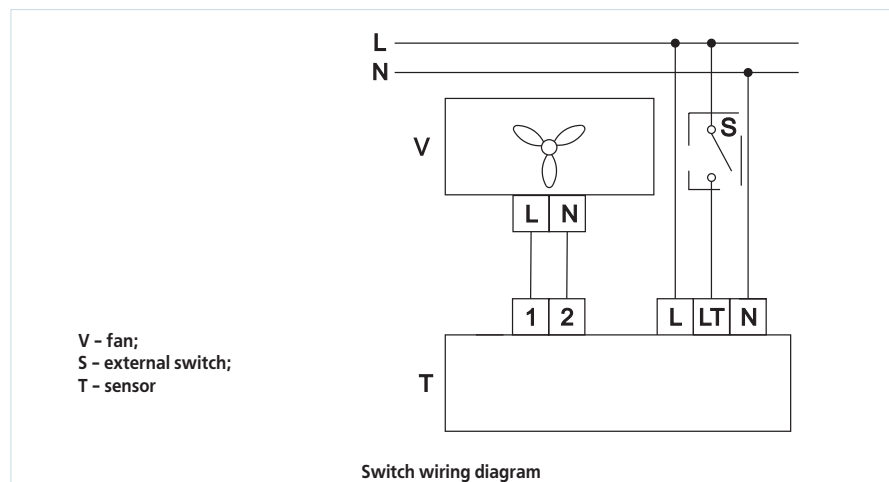



## WIRING DIAGRAMS\*

<b>Fans</b>				
<b>Fans for round ducts</b>		<b>Wiring diagram number</b>		
<b>TT</b>				
TT 100		27		
TT 125		27		
TT 125 S		29		
TT 150		29		
TT 160		29		
TT 200		30		
TT 250		30		
TT 315		30		
<b>VK</b>				
VK 100 Q		3		
VK 100		3		
VK 125 Q		3		
VK 125		3		
VK 150		3		
VK 200		3		
VKS 200		3		
VK 250 Q		3		
VK 250		3		
VK 315		3		
VKS 315		3		
<b>VKM</b>				
VKM 100 Q		2		
VKM 100		5		
VKM 125 Q		2		
VKM 125		5		
VKM 150		5		
VKM 160		5		
VKM 200		5		
VKMS 200		5		
VKM 250 Q		5		
VKM 250		5		
VKM 315		5		
VKMS 315		5		
VKM 355 Q		5		
VKM 400		5		
VKM 450		5		
<b>VKMz</b>				
VKMz 100 Q		2		
VKMz 100		5		
VKMz 125 Q		2		
VKMz 125		5		
VKMz 150		5		
VKMz 160		5		
VKMz 200 Q		5		
VKMz 200		5		
VKMz 250 Q		5		
VKMz 250		5		
VKMz 315 Q		5		
VKMz 315		5		
<b>VC</b>				
VC-VK 100 Q		2		
VC-VK 100		5		
VC-VK 125 Q		2		
VC-VK 125		5		
VC-VK 150		5		
VC-VK 160		5		
VC-VK 200		5		
VCS-VK 200		5		
VC-VK 250 Q		5		
VC-VK 250		5		
VC-VK 315		5		
VCS-VK 315		5		
VC-VN 100 Q		2		
VC-VN 100		5		
VC-VN 125 Q		2		
VC-VN 125		5		
VC-VN 150		5		
VC-VN 160		5		
VC-VN 200		5		
VCS-VN 200		5		
VC-VN 250 Q		5		
VC-VN 250		5		
VC-VN 315		5		
VCS-VN 315		5		
VC-PK 100 Q		2		
VC-PK 100		5		
VC-PK 125 Q		2		
VC-PK 125		5		
VC-PK 150		5		
VC-PK 160		5		
VC-PK 200		5		
VCS-PK 200		5		
VC-PK 250 Q		5		
VC-PK 250		5		
VC-PK 315		5		
VCS-PK 315		5		
VC-PN 100 Q		2		
VC-PN 100		5		
VC-PN 125 Q		2		
VC-PN 125		5		
VC-PN 150		5		
VC-PN 160		5		
VC-PN 200		5		
VCS-PN 200		5		
VC-PN 250 Q		5		
VC-PN 250		5		
VC-PN 315		5		
VCS-PN 315		5		
<b>VCN</b>				
VCN 100		5		
VCN 125		5		
VCN 150		5		
VCN 160		5		
VCN 200		5		
<b>VKP mini</b>				
VKP 80 mini		11		
VKP 80/80*2 mini		11		
VKP 80/80*4 mini		11		
VKP 100 mini		11		
VKP 100/80*2 mini		11		
VKP 100/80*4 mini		11		
VKP 100/100*2 mini		11		
VKP 100/100*4 mini		11		
<b>VKP round</b>				
VKP 100		5		
VKP 125		5		
VKP 150		5		
VKP 160		5		
<b>Chimney fans</b>			<b>Wiring diagram number</b>	
<b>KAM</b>				
KAM 125		2		
KAM 125 T1		31		
KAM 140		2		
KAM 140 T1		31		
KAM 150		2		
KAM 150 T1		31		
KAM 160		2		
KAM 160 T1		31		
KAM 125 Eco		2		
KAM 125 Eco T1		31		
KAM 140 Eco		2		
KAM 140 Eco T1		31		
KAM 150 Eco		2		
KAM 150 Eco T1		31		
KAM 160 Eco		2		
KAM 160 Eco T1		31		
KAM 125 EcoDuo		2		
KAM 125 EcoDuo T1		32		
KAM 140 EcoDuo		2		

\* The shown wiring diagrams are for information only, for details refer the user's manual of the good.

KAM 140 EcoDuo T1	32	VKP 4E 500x300	5	<b>CENTRIFUGAL FANS</b>	<b>Wiring diagram number</b>
KAM 150 EcoDuo	2	VKP 4D 500x300	15		
KAM 150 EcoDuo T1	32	VKP 4E 600x300	5		
KAM 160 EcoDuo	2	VKP 4D 600x300	14		
KAM 160 EcoDuo T1	32	VKP 4E 600x350	5		
		VKP 4D 600x350	19		
<b>RECTANGULAR DUCT FANS</b>	<b>Wiring diagram number</b>	<b>VKPI</b>			
<b>VKPF</b>		VKPI 2E 400x200	5		
VKPF 4E 400x200	10	VKPI 2E 500x250	5		
VKPF 4D 400x200	22	VKPI 4E 500x300	5		
VKPF 4E 500x250	10	VKPI 4D 500x300	15		
VKPF 4D 500x250	22	VKPI 4E 600x300	5		
VKPF 4E 500x300	10	VKPI 4D 600x300	14		
VKPF 4D 500x300	22	VKPI 4E 600x350	5		
VKPF 4E 600x300	10	VKPI 4D 600x350	19		
VKPF 4D 600x300	22	<b>SOUND-INSULATED FANS</b>	<b>Wiring diagram number</b>		
VKPF 4E 600x350	10	<b>VS</b>			
VKPF 4D 600x350	22	VS 355-4E	5		
VKPF 4D 700x400	23	VS 355-4D	19		
VKPF 6D 800x500	23	VS 400-4E	8		
VKPF 4D 800x500	23	VS 400-4D	25		
VKPF 6D 900x500	23	VS 450-4E	8		
VKPF 6D 1000x500	23	VS 450-4D	19		
<b>VKPI</b>		VS 500-4E	8a		
VKPI 4E 400x200	10	VS 500-4D	19		
VKPI 4D 400x200	22	VS 560-4D	19		
VKPI 4E 500x250	10	VS 560-6D	19		
VKPI 4D 500x250	22	VS 630-4D	19		
VKPI 4E 500x300	10	VS 630C-4D	19		
VKPI 4D 500x300	22	VS 630-6D	19		
VKPI 4E 600x300	10	VS 710-6D	25		
VKPI 4D 600x300	22	<b>KSA</b>			
VKPI 4E 600x350	10	KSA 100-2E	5		
VKPI 4D 600x350	22	KSA 125-2E	5		
VKPI 4D 700x400	23	KSA 150-2E	5		
VKPI 6D 800x500	23	KSA 160-2E	5		
VKPI 4D 800x500	23	KSA 200-4E	5		
VKPI 6D 900x500	23	KSA 250-4E	8		
VKPI 6D 1000x500	23	KSA 315-4E	8		
<b>VKP with EC motor</b>		<b>KSB</b>			
VKP 600x300 EC	26a	KSB 100	2		
VKP 600x350 EC	26b	KSB 125	2		
VKP 700x400 EC	26d	KSB 150	2		
VKP 800x500 EC	26c	KSB 160	2		
VKP 1000x500 EC	26c	KSB 200	2		
<b>Rectangular VKP</b>		KSB 200 S	2		
VKP 2E 400x200	5	KSB 250	2		
VKP 2E 500x250	5	KSB 315	2		
				<b>VCU</b>	
				VCU 2E 140x60	5
				VCU 2E 160x62	5
				VCU 2E 160x90	5
				VCU 4E 180x92	5
				VCU 4E 200x80	5
				VCU 4E 200x102	5
				VCU 4E 225x102	8
				VCU 4E 250x140	8
				<b>VCUN</b>	
				VCUN 140x74-0,25-4	15
				VCUN 140x74-0.37-2	15
				VCUN 160x74-0,55-4	15
				VCUN 160x74-0,75-2	15
				VCUN 180x74-0,55-4	15
				VCUN 180x74-1,1-2	15
				VCUN 200x93-0,55-4	15
				VCUN 200x93-1,1-2	15
				VCUN 225x103-1,1-4	15
				VCUN 225x103-2,2-2	15
				VCUN 240x114-2,2-4	15
				VCUN 240x114-3,0-2	15
				VCUN 250x127-1,5-6	15
				VCUN 250x127-2,2-4	15
				VCUN 250x127-5,5-2	15
				VCUN 280x127-1,5-6	15
				VCUN 280x127-2,2-4	15
				VCUN 280x127-5,5-2	15
				VCUN 315x143-2,2-6	15
				VCUN 315x143-4,0-4	15
				VCUN 355x143-2,2-6	15
				VCUN 355x143-4,0-4	15
				VCUN 400x183-1,5-8	15
				VCUN 400x183-2,2-6	15
				VCUN 400x183-5,5-4	15
				VCUN 450x203-3,0-8	15
				VCUN 450x203-4,0-6	15
				VCUN 450x203-11,0-4	15
				VCUN 500x229-5,5-8	15
				VCUN 500x229-7,5-6	15
				VCUN 500x229-11,0-4	15
				<b>Axial fans</b>	<b>Wiring diagram number</b>
				<b>OV</b>	
				OV 2E 200	4
				OV 2E 250	4

\* The shown wiring diagrams are for information only, for details refer the user's manual of the good.

## WIRING DIAGRAMS\*

OV 4E 250	4	VKF 4E 500	4	VKH 2E 250	5
OV 2E 300	4	VKF 4E 550	4	VKH 2E 280	5
OV 4E 300	4	VKF 4E 630	4	VKH 4E 310	5
OV 4E 350	4	VKF 2D 250	12	VKH 4D 310	12
OV 4E 400	4	VKF 4D 250	12	VKH 4E 355	5
OV 4E 450	4	VKF 2D 300	12	VKH 4D 355	19
OV 4E 500	4	VKF 4D 300	12	VKH 4E 400	9
OV 4E 550	4	VKF 4D 350	12	VKH 4D 400	19
OV 4E 630	4	VKF 4D 400	12	VKH 4E 450	9
OV 2D 250	12	VKF 4D 450	12	VKH 4D 450	19
OV 4D 250	12	<b>OV1</b>		VKH 6E 500	9
OV 2D 300	12	OV1 150	2	<b>VKMK</b>	
OV 4D 300	12	OV1 200	2	VKMK 150 / VKMKp 150	5
OV 4D 350	12	OV1 250	2	VKMK 200 / VKMKp 200	5
OV 4D 400	12	OV1 315	2	VKMK 250 / VKMKp 250	5
OV 4D 450	12	<b>OVK1</b>		VKMK 315 / VKMKp 315	5
<b>OVK</b>		OVK1 150	2	<b>Axial roof fans</b>	<b>Wiring diagram number</b>
OVK 2E 200	4	OVK1 200	2	<b>VOK</b>	
OVK 2E 250	4	OVK1 250	2	VOK 2E 200	5
OVK 4E 250	4	OVK1 315	2	VOK 2E 250	5
OVK 2E 300	4	<b>VKOM</b>		VOK 4E 250	5
OVK 4E 300	4	VKOM 150	2	VOK 2E 300	5
OVK 4E 350	4	VKOM 200	2	VOK 4E 300	5
OVK 4E 400	4	VKOM 250	2	VOK 4E 350	5
OVK 4E 450	4	VKOM 315	2	<b>VOK1</b>	
OVK 4E 500	4	<b>CENTRIFUGAL ROOF FANS</b>	<b>Wiring diagram number</b>	VOK1 200	2
OVK 4E 550	4	<b>VKV</b>		VOK1 250	2
OVK 4E 630	4	VKV 2E 220	5	VOK1 315	2
OVK 2D 250	12	VKV 2E 225	5		
OVK 4D 250	12	VKV 2E 250	5		
OVK 2D 300	12	VKV 2E 280	5		
OVK 4D 300	12	VKV 4E 310	5		
OVK 4D 350	12	VKV 4D 310	12		
OVK 4D 400	12	VKV 4E 355	5		
OVK 4D 450	12	VKV 4D 355	19		
<b>VKF</b>		VKV 4E 400	9		
VKF 2E 200	4	VKV 4D 400	19		
VKF 2E 250	4	VKV 4E 450	9		
VKF 4E 250	4	VKV 4D 450	19		
VKF 2E 300	4	VKV 6E 500	9		
VKF 4E 300	4	<b>VKH</b>			
VKF 4E 350	4	VKH 2E 220	5		
VKF 4E 400	4	VKH 2E 225	5		
VKF 4E 450	4				

\* The shown wiring diagrams are for information only, for details refer the user's manual of the good.

Single-phase motor with no capacitor

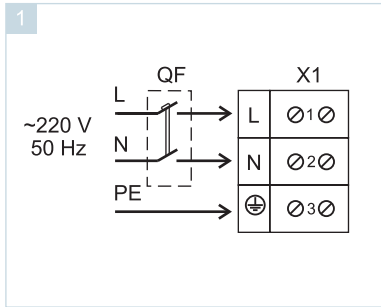

Single-phase motor with no capacitor

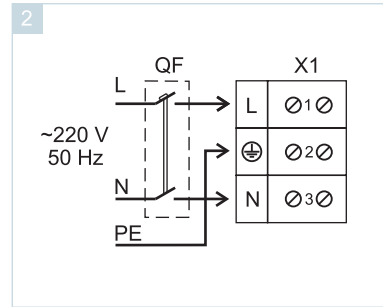

Single-phase motor with no capacitor

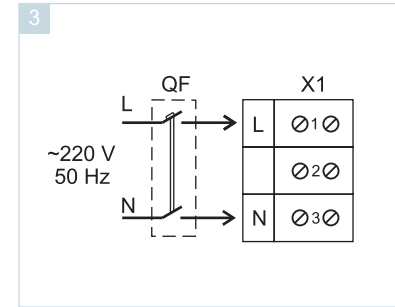

Single-phase motor with capacitor

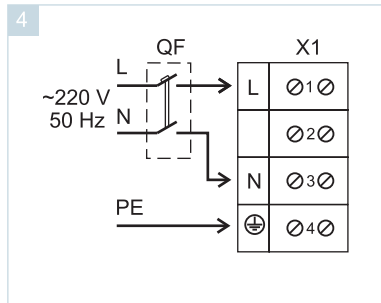

Single-phase motor with capacitor

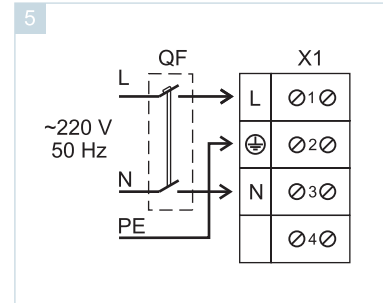

Single-phase motor with capacitor

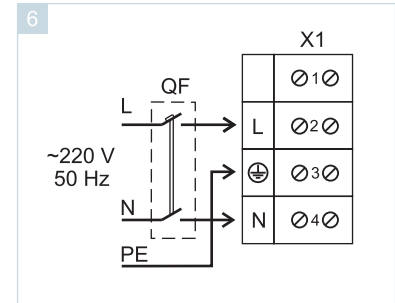

Single-phase motor with capacitor

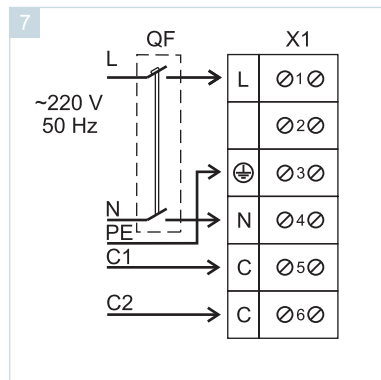

Single-phase motor with capacitor and thermal switch

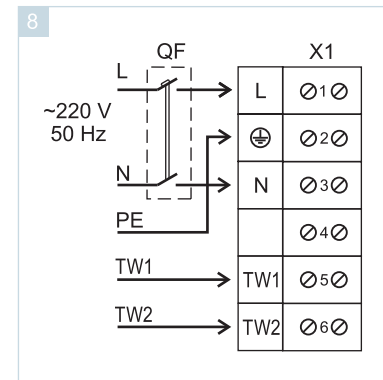

Single-phase motor with capacitor and thermal switch

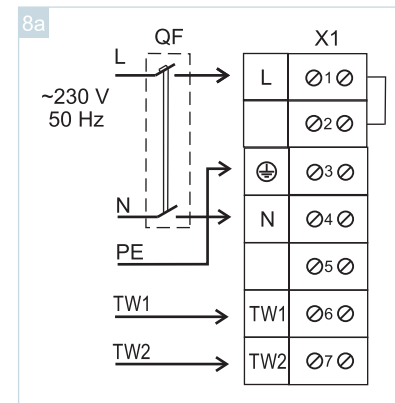

Single-phase motor with capacitor and thermal switch

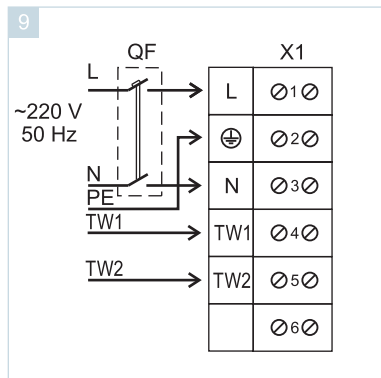

Single-phase motor with capacitor and thermal switch

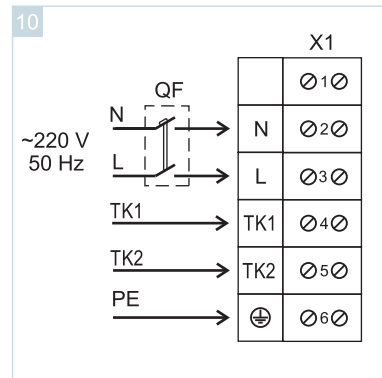

Single-phase motor with PCB and switch

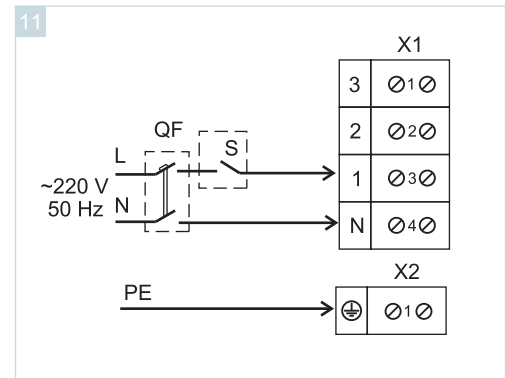

\* The shown wiring diagrams are for information only, for details refer the user's manual of the good.

Three-phase motor.  
Y-connection (delta-connection)  
in the motor

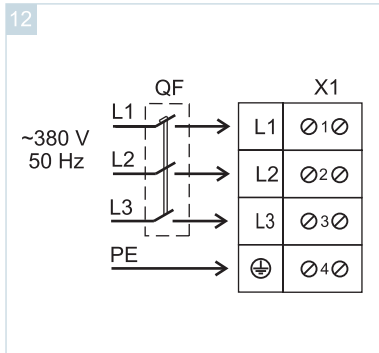

Three-phase motor  
with thermal switch.  
Y-connection (delta-connection)  
in the motor

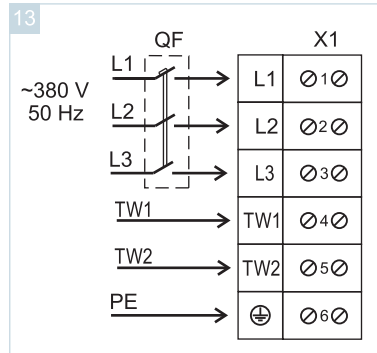

Three-phase motor  
with thermal switch.  
Y-connection (delta-connection)  
in the motor

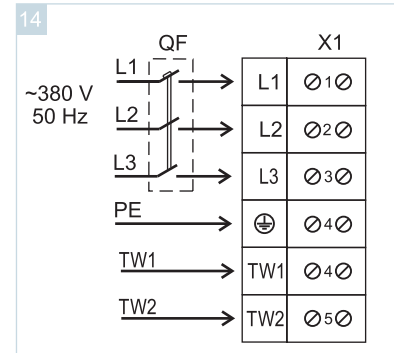

Three-phase motor.  
Y-connection on the terminal box.

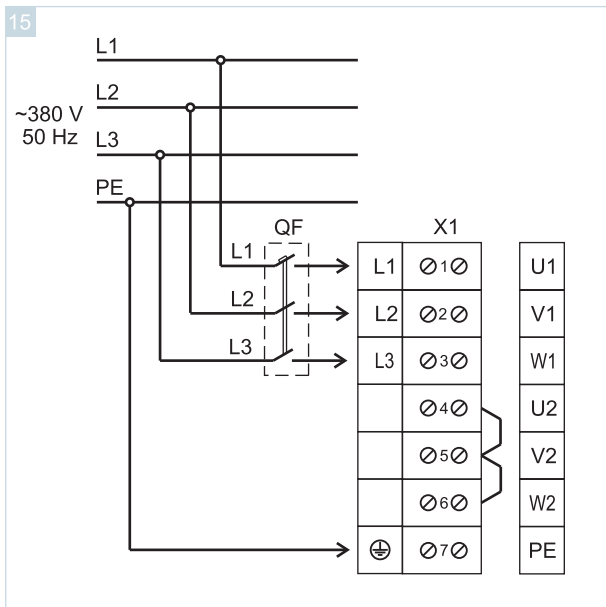

Three-phase motor.  
Y-connection on the terminal box.

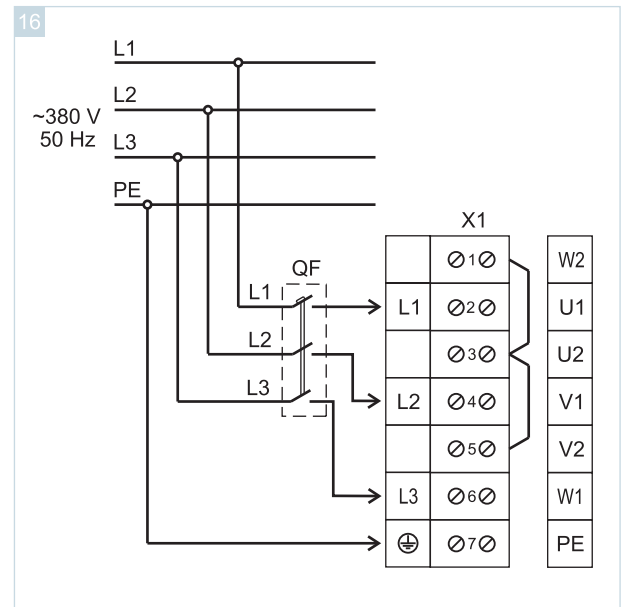

Three-phase motor.  
Delta-connection on the terminal box.

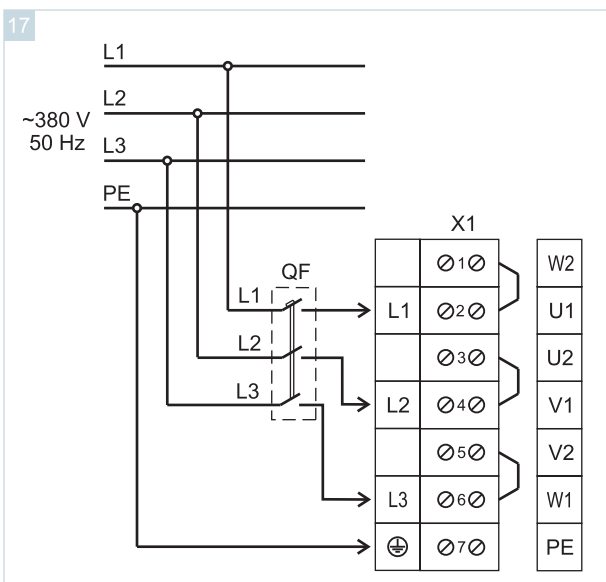

Three-phase motor.  
Delta-connection on the terminal box.

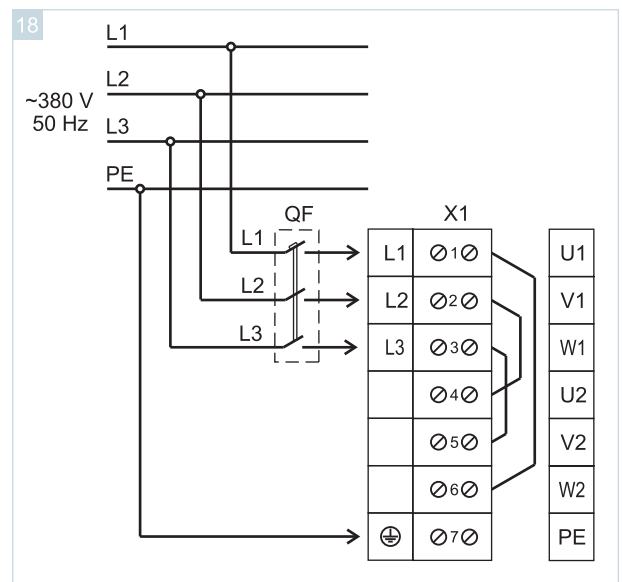

\* The shown wiring diagrams are for information only, for details refer the user's manual of the good.

Three-phase motor.  
Y-terminal block with thermal protection  
contacts leaded outside.

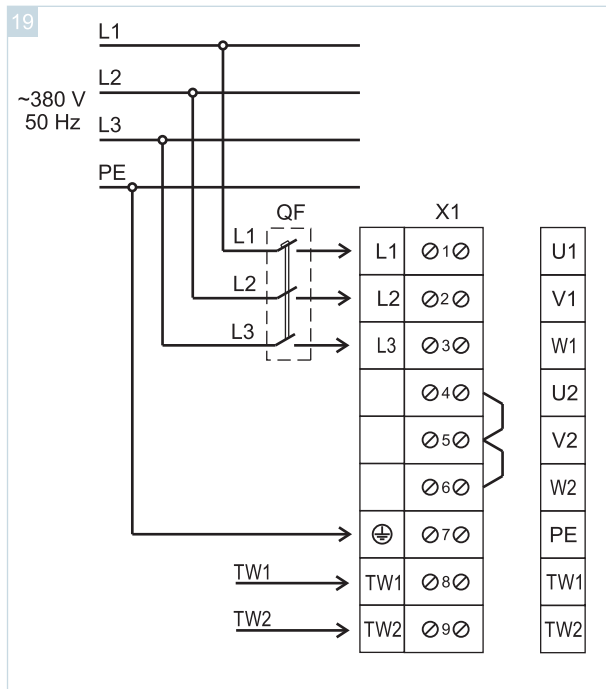

Three-phase motor.  
Y-terminal block with thermal protection  
contacts leaded outside.

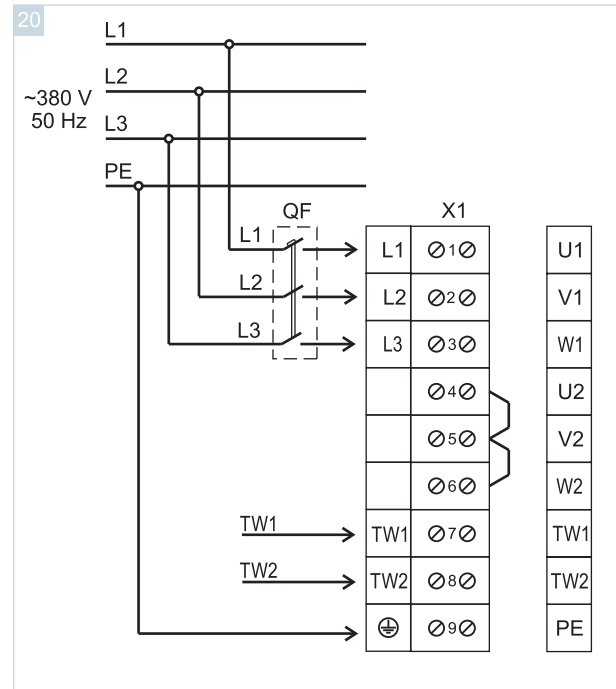

Three-phase motor.  
Y-terminal block with thermal protection  
contacts leaded outside.

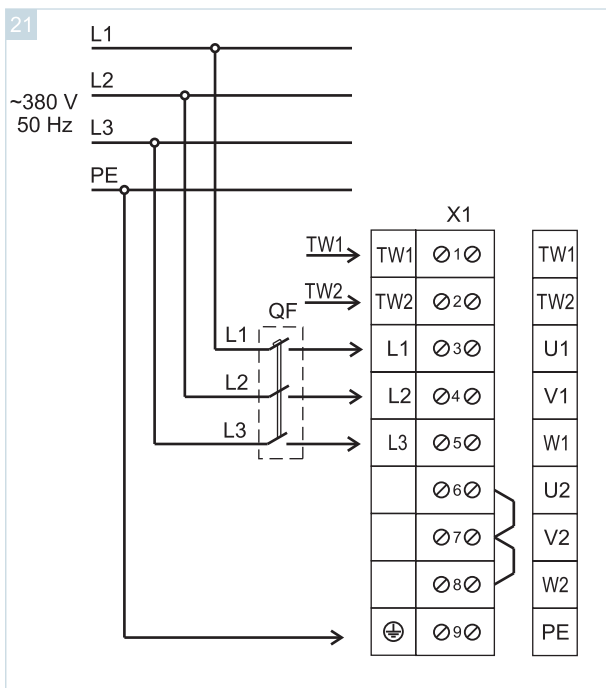

Three-phase motor.  
Y-terminal block with thermal protection  
contacts leaded outside.

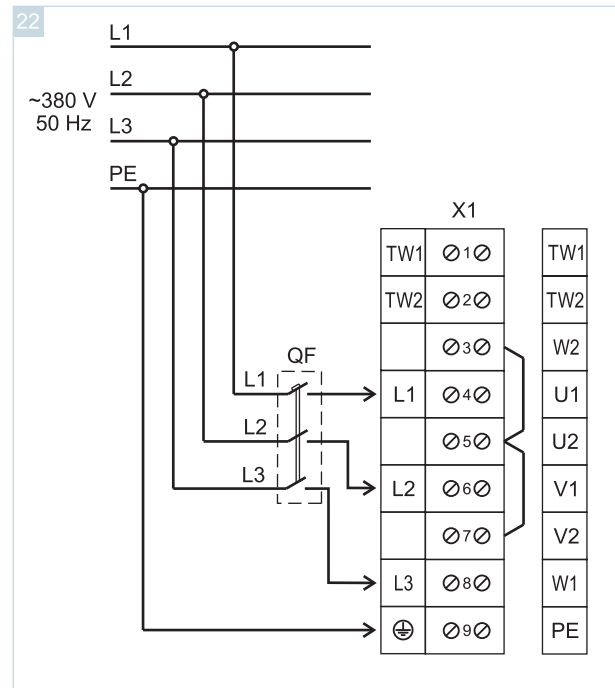

\* The shown wiring diagrams are for information only, for details refer the user's manual of the good.



Three-phase motor.  
Delta-terminal block with thermal protection contacts led outside.

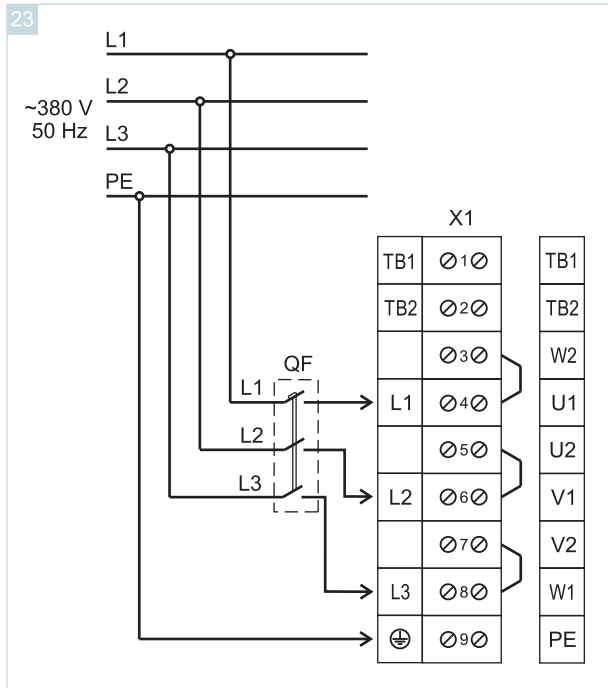

Three-phase motor.  
Delta-terminal block with thermal protection contacts led outside.

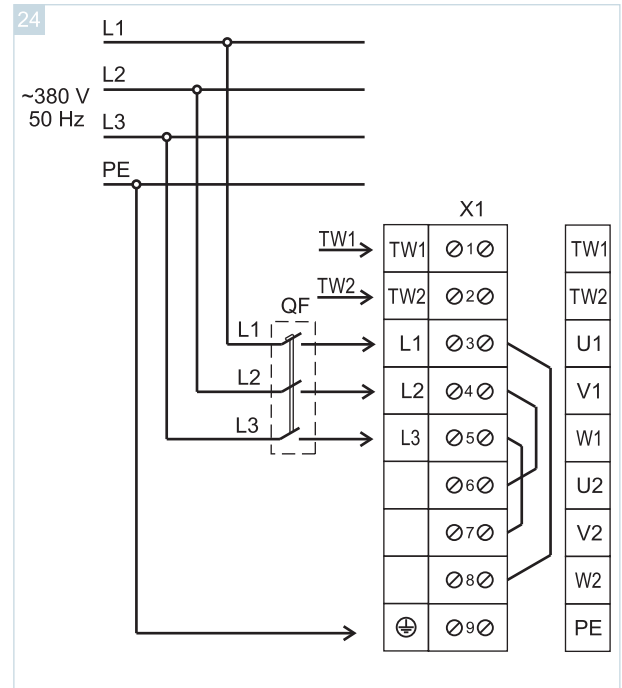

Three-phase motor.  
Delta-terminal block with thermal protection contacts led outside.

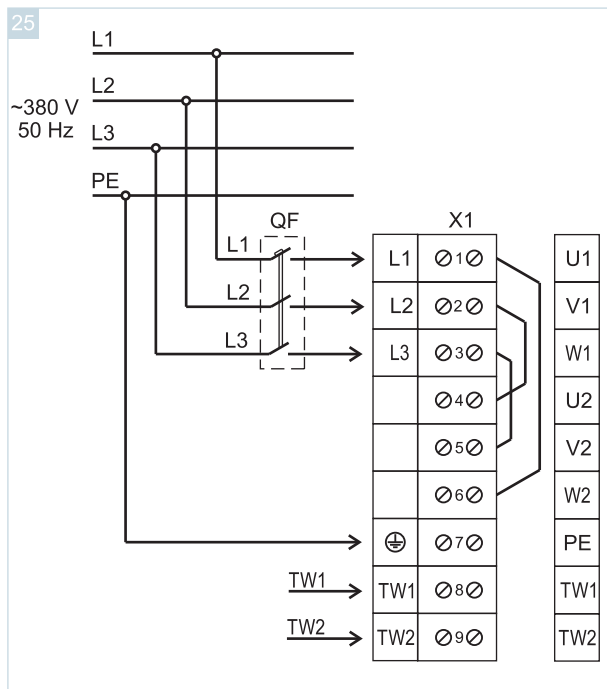

EC motor

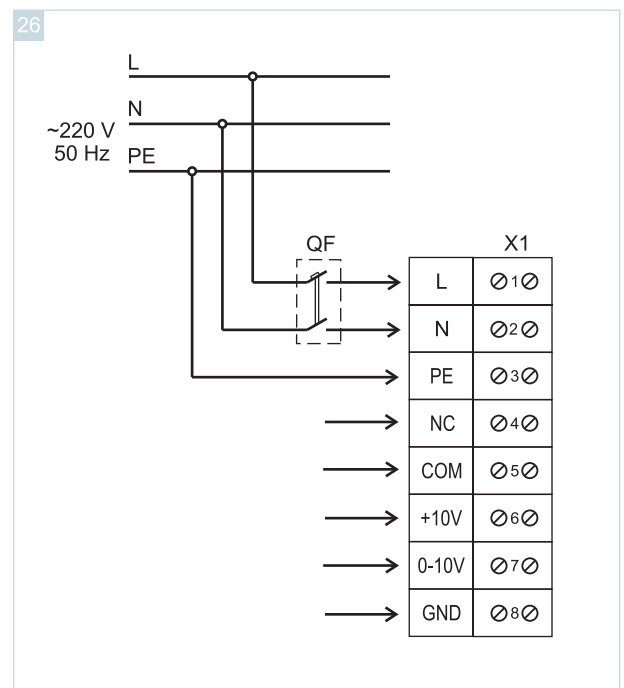

\* The shown wiring diagrams are for information only, for details refer the user's manual of the good.

VKP 600x300 EC fans wiring diagram

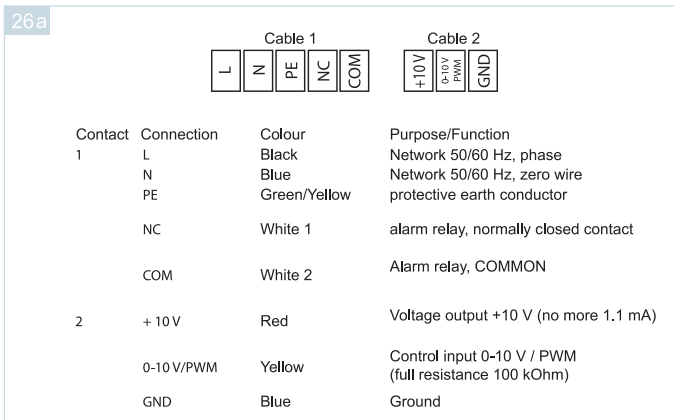

VKP 600x350 EC fans wiring diagram

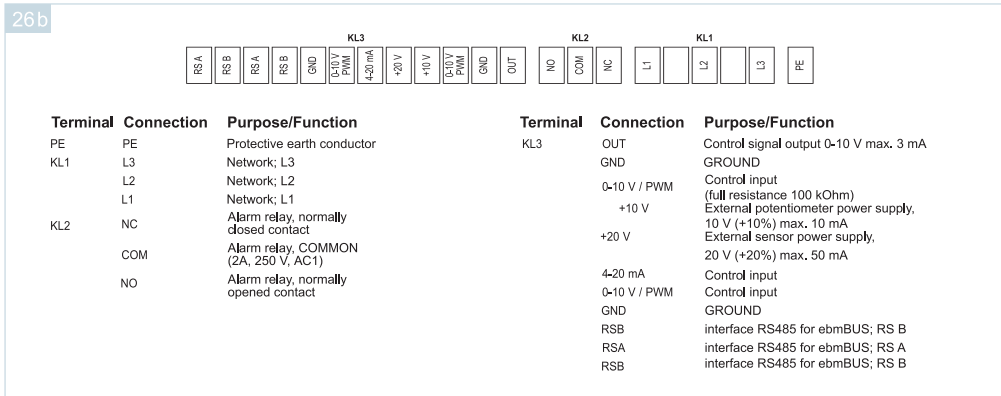

VKP 800x500 EC, VKP 1000x500 EC fans wiring diagram

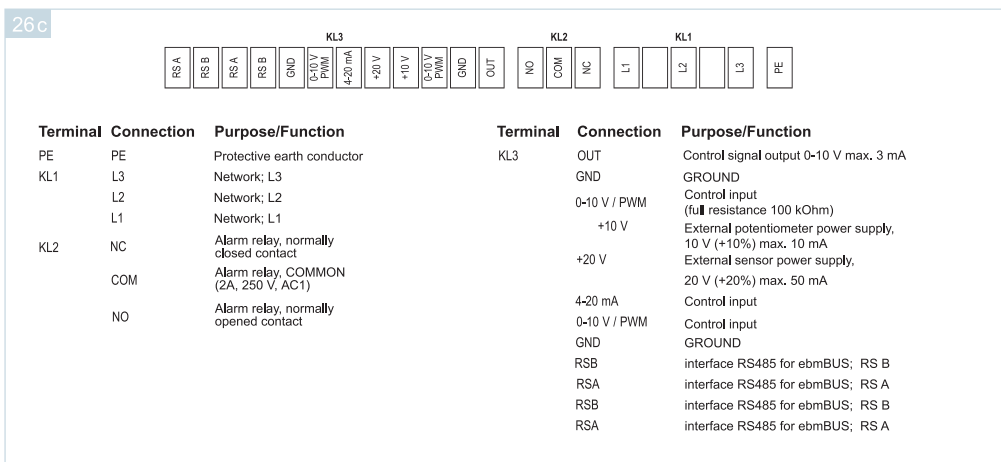

\* The shown wiring diagrams are for information only, for details refer the user's manual of the good.

VKP 700x400 EC fans wiring diagram

26 d

		KL3						KL2			KL1			
	Din2	Din3	GND	Ain2 U	+20 V	Ain2 I	Aout	NO	COM	NC	PE	L1	L2	L3
	RSA	RS B	GND	Ain1 U	+10 V	Ain1 I	Din1							

Terminal	Connection	Purpose/Function	Terminal	Connection	Purpose/Function
KL1	L3	Network; L3	KL3	Din1	Digital input 1 (automation release-blocking) Release: Pin is open or the set voltage is 5-50V Blocking: Pin is closed for GND or the set voltage is <1V
	L2	Network; L2		Ain1 I	Analog input of set values, 4-20 mA (resistance 100 kOhm), exclusively as an option for connection with Ain1 U
	L1	Network; L1		+10 V	external potentiometer power supply, 10 V (±3%) max. 10 mA
PE	PE	Protective earth conductor	Ain1U	Analog input of set values, 0-10 V (resistance 100 kOhm), exclusively as an option for connection with Ain1 U	
KL2	NC	Alarm relay, normally closed contact	GND	GROUND	
	COM	Alarm relay, COMMON (2A, 250 V, AC1)	RSB	interface RS485 for MODBUS RTU; RS B	
	NO	Alarm relay, normally opened contact	RSA	interface RS485 for MODBUS RTU; RS	
			Aout	Analog input of set values, 0-10 V, max. 5 mA, (resistance 100 kOhm), actual motor speed value / motor speed factor value output	
			Ain2 I	Analog input of set values, 4-20 mA (resistance 100 kOhm), exclusively as an option for connection with Ain2 U	
			+20 V	External sensor power supply, 20V (+25%/-10%) max. 40 mA	
			Ain2 U	Analog input of set values, 0-10 V (resistance 100 kOhm), exclusively as an option for connection with Ain2 I	
			GND	GROUND	
			Din3	Digital input 3 (normal/return switching). The controller preset value are available for selection in interface and digital input norm./return.	
			Din2	Digital input 2 (day/night mode switch) The preset parameters are available for selection in interface and digital input norm./return, input 2 (day/night mode switch) Day: Pin is open or the set voltage is 5...50V Night: Pin is closed for GND or the set voltage is <1 V	

TT fans wiring diagrams

TT 100,  
TT 125,

TT 100T,  
TT 125T,  
TT 125 ST,  
TT 150T,  
TT 160T

TT 125 S,  
TT 150,  
TT 160

TT 200,  
TT 250,  
TT 315

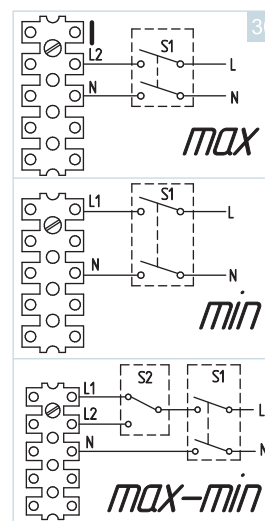
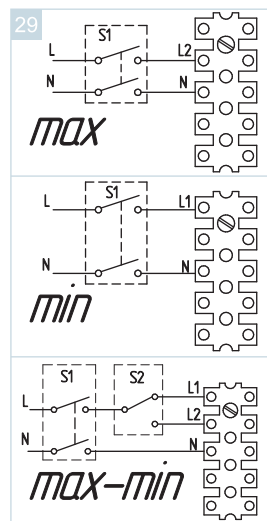
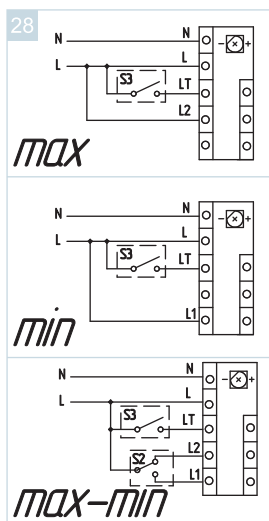
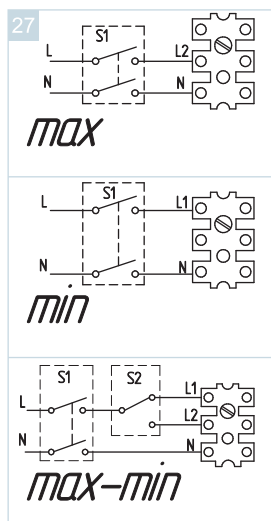

\* The shown wiring diagrams are for information only, for details refer the user's manual of the good.

Wiring diagram for KAM T1  
single-phased motor fan to AC network

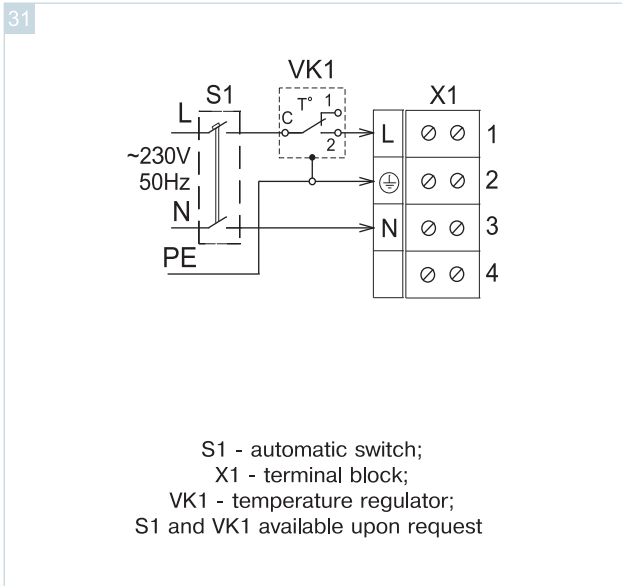

Wiring diagram for KAM EcoDuo T1  
single-phased motor fan to AC network.

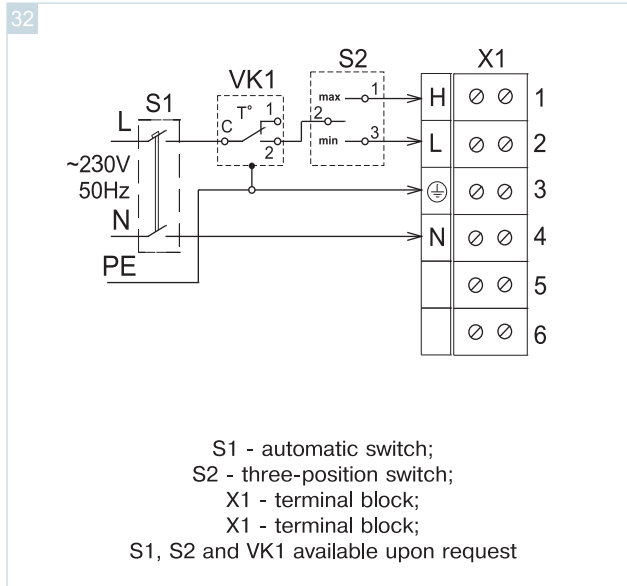

\* The shown wiring diagrams are for information only, for details refer the user's manual of the good.

## ALPHABETIC INDEX

<b>A</b>					
AirVents.....	221				
AV.....	221				
AOW.....	228				
<b>C</b>					
C.....	305				
CB.....	305				
CBR.....	305				
CZ.....	304				
CZK.....	304				
<b>F</b>					
FB.....	248, 249				
FBV.....	248				
FBK.....	250, 252				
FVZn.....	118				
FFK.....	86				
<b>G</b>					
GFK.....	86				
<b>K</b>					
KAM.....	86				
KAM Eco.....	86				
KAM EcoDuo.....	86				
KG.....	300				
KOM.....	294				
KOM1.....	295				
KR.....	296, 297				
KRA.....	296, 297				
KSA.....	100				
KSB.....	104				
KFK.....	86				
<b>M</b>					
MKF.....	86				
MPA...W.....	162				
MPA...E.....	162				
<b>N</b>					
NK.....	254, 258				
NKW.....	262, 268				
<b>O</b>					
OV.....	128				
OV1.....	134				
OVK.....	128				
OVK1.....	134				
OKW.....	282				
OKF.....	288				
<b>P</b>					
P2-1-300.....	323				
P2-5,0.....	322				
P3-1-300.....	323				
P3-5,0.....	322				
P5-5,0.....	322				
PA...W.....	172				
PA...E.....	172				
PVZ.....	232				
PVK.....	33				
PK.....	238				
PR.....	238				
PTT.....	23				
<b>R</b>					
R-1/010.....	324				
RVZn.....	118				
RRV.....	298				
RRVA.....	298				
RRVAF.....	298				
RS.....	311, 312, 313				
RS-1-300.....	310				
RS-1-400.....	310				
RSA5D.....	317, 318				
RSA5E.....	314, 315, 316				
RT.....	321				
RTS.....	320				
RTSD.....	320				
<b>S</b>					
SKRA.....	302				
SR.....	240, 246				
SRN.....	244				
SRP.....	244				
SRF.....	240				
SF.....	248				
SFV.....	248				
SFK.....	250				
<b>T</b>					
T.....	325				
TH.....	325				
TP.....	325				
TS-1-90.....	89				
TT.....	22				
TTP.....	30				
TTS.....	30				
TF.....	325				
<b>V</b>					
VA.....	180				
VVG.....	94, 95, 301				
VVGF.....	301				
VVZnr.....	118				
VVZnp.....	118				
VK.....	32				
VKV.....	142				
VK VMS.....	36				
VKH.....	142				
VKM.....	38				
VKMK.....	148				
VKMKp.....	148				
VKMz.....	42				
VKOM.....	134				
VKP.....	54, 78				
VKP EC.....	74				
VKP mini.....	56				
VKPI.....	78				
VKPF.....	66				
VKPF1.....	66				
VKF.....	128				
VL.....	238				
VOK.....	150				
VOK1.....	152				
VPA.....	158				
VPG.....	94, 95				
VUT mini.....	188				
VUT mini EC.....	190				
VUT...H.....	192				
VUT...H EC.....	196				
VUT...PW EC.....	210				
VUT...PE EC.....	210				
VUT...EH (WH).....	198				
VUT...EH EC.....	204				
VUT...WH EC.....	204				
VFED.....	319				
VC.....	46				
VC-VK.....	46				
VC-VN.....	46				
VCN.....	50				
VC-PK.....	46				
VC-PN.....	46				
VCU.....	112				
VCUN.....	116				
VS.....	94				
<b>U</b>					
USWK.....	280				
<b>X</b>					
X-Vent.....	218				



**ВЕНТИЛЯЦИОННЫЕ СИСТЕМЫ**  
[www.ventilation-system.com](http://www.ventilation-system.com)

промышленная и коммерческая  
вентиляция



**ВЕНТС** оставляет за собой право вносить любые изменения,  
вызванные необходимостью производства, без уведомления