

AIR HANDLING UNITS

airVENTS



CATALOGUE 2010

C O N T E N T S

About the company	1
Manufacturing facilities	2
AirVents air handling units	3
How to select a unit	4
Unit designation	6
Service access side	7
Quick selection	8
Exhaust units	10
Supply units	12
Heat recovery units	16
Section dimensions	20
Fan curves	24
Sections description	38
Control system	45
Standard control system examples	47
Integration with BMS systems	52
Mollier diagram	53
Inquiry form	55



ABOUT THE COMPANY



Welcome to the world of VENTS!

VENTS was established in 1990-s. Dynamic development and research of customer's demands allowed us to become one of market leaders in a short term.

International Market

Our products are represented in more than 80 countries and this fact proves the reliability of our company as well as the high quality of manufactured products. Our company is a full-fledged member of HARDI association since year 2008. This is the largest specialized association in HVACR (heating, ventilation, air conditioning and refrigeration systems) sector which represents the largest operators of the market of climatic equipment. Worldwide recognition has strengthened the company's position as a competent actor and the leader of international ventilation market.

MANUFACTURING FACILITIES



Vents for you

Today VENTS gives employment to nearly 2000 professionals providing product's full manufacturing cycle – starting from idea generation and all the way to the end product. The company's production facilities are placed on more than 60 000 m² and include 12 manufacturing departments equipped in accordance with international standards. Each of these manufacturing departments may be compared with a substantive factory.

Currently VENTS is one of the world leading manufacturers in ventilation owing to its modern hi-tech equipment which conforms to international standards and large-scale implementation of advanced technologies. Basic research and effective innovations in climatic equipment sector both take up a significant part in development strategy implemented by the company.

Our own manufacturing facilities, construction departments and development laboratories allow us to produce only high-quality products.

Special attention is devoted to the quality of produced equipment. The quality control system, implemented by the company, complies with requirements of ISO 9001:2000 standards and this fact is confirmed by certificate of international authority. The product quality is confirmed not only by Ukrainian certificate but also by international certificates of Germany, USA, Poland, Czech Republic and Russia.



With VENTS you can always choose the most suitable ventilation solution. We produce a full range of ventilation equipment including plastic and metal ducts and fittings, vast range of grills and diffusers, residential exhaust fans and equipment for commercial and industrial ventilation: wide range of heat recovery units, fans, and a full range of air handling and distribution elements.

AIRVENTS AIR HANDLING UNITS

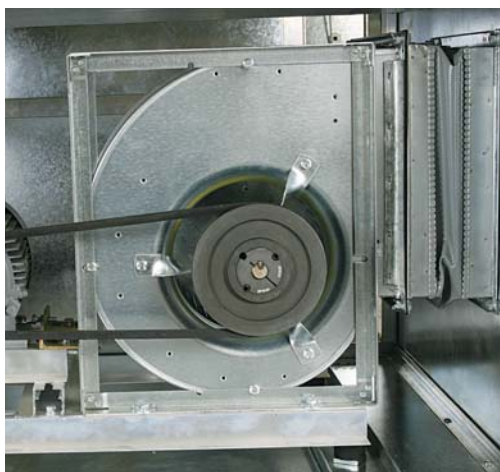

AirVents air handling units are intended for providing centralized ventilation in medium and large buildings such as office centers, sport arenas or shopping malls.

All basic functions such as heating, cooling, filtration, humidification and heat recovery are acceptable.

A user friendly and reliable control system allows selecting required functions and supervising all processes in the unit.

Units are manufactured to provide a full process of air preparation. Each unit is custom-designed and assembled of separate sections selected and arranged to meet customer's individual requirements.

Using high-quality components supplied by world leading manufacturers ensures reliable operation at high energy efficiency levels.

Each unit is completely assembled and tested at our plant even if it is transported as a number of separate sections to its final destination.

HOW TO SELECT A UNIT

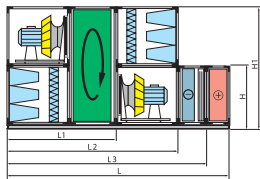
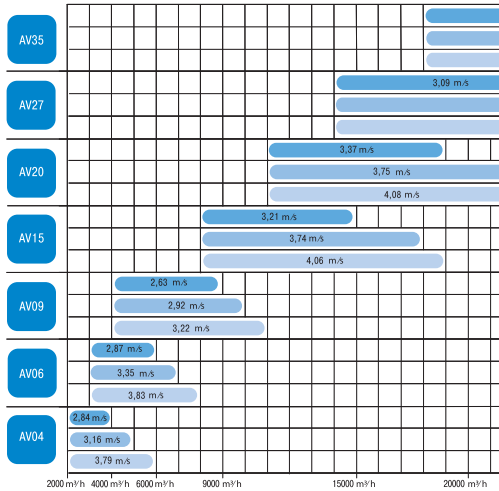

- OPTIONAL ELEMENTS**
- air damper
- OPTIONAL FUNCTIONAL SECTIONS**
- silencer
 - filter
 - mixing section
 - inspection block
- (see description on page 22-25)

Type	length, L1 [m]	length, L2 [m]	length, L3 [m]	length, L [m]	height, H1 [m]	height, H2 [m]	height, H3 [m]	height, H [m]	intensity, d [m]	weight [kg]
AV04	1,39	2,19	2,54	3,05	0,73	1,33	1,2	0,7 x 0,4	480-500	
AV06	1,49	2,29	2,78	3,29	0,81	1,48	1,35	0,8 x 0,5	625-695	
AV09	1,72	2,85	3,24	3,77	0,97	1,86	1,73	1 x 0,5	644-696	
AV15	1,75	2,88	3,27	3,76	1,16	2,24	2,11	1,2 x 0,9	834-886	
AV20	1,75	2,88	3,27	3,76	1,26	2,44	2,31	1,4 x 1	1016-1116	
AV27	1,82	2,95	3,34	3,97	1,34	2,61	2,47	2 x 1	1316-1480	
AV35	1,72	2,85	3,24	3,87	1,42	2,77	2,64	2 x 1,2	1316-1676	

AirVents technical specification data sheet

Company: _____ / Building: _____ Tell: _____
 Contact person: _____ E-mail: _____
 Tell: _____ www.vents.us
 E-mail: _____

General

Units: Exhaust Supply Supply & exhaust Supply & exhaust with heat recovery

Mounting: Outdoor Indoor Access side: Left Right

Supply & exhaust parts: Lineary Side by side One on other

Capacity and pressure

Supply Exhaust

Capacity: _____ m³/hour _____ m³/hour
 Pressure (system resistance): _____ Pa _____ Pa

Air parameters

	Winter	Summer
Supply Outdoor air temperature and relative humidity °C % °C %
Conditioned air temperature and relative humidity °C % °C %
Exhaust Extract air temperature and relative humidity °C % °C %
Exhaust Exhaust air temperature and relative humidity °C % °C %

Sections required

Fan: Belt-driven Plug fan

Filter: Supply G4 F7 Other: _____
 Exhaust G4 F7 Other: _____

Heater: Air temp. before / after heater: _____ °C
 Electric: Heater power: _____ kWt

Mixing set: Water temp. before / after heater: _____ °C

Cooling section: Air temp. before / after heater: _____ °C
 Freon: Heater power: _____ kWt
 Mixing set: Water temp. before / after heater: _____ °C

Heat recovery section: Inlet temperature: _____ °C Outlet temperature: _____ °C
 Plates: Inlet humidity: _____ % Outlet humidity: _____ %
 Rotor: Efficiency: _____ %

Supply

Air handling units (AHU) are rather complicated pieces of equipment to specify and order, because a vast array of choices is available, and because there is no single-number identifier (e.g., a "20 000 m³/h unit") that adequately describes the desired product. In addition to size and type, in order to give you the optimal solution our engineers must properly determine an air-handling unit's required supply air temperature and volume; outside air temperatures in summer and winter; air filtration rate; heating and cooling coil capacities; humidification and dehumidification capacities; supply, and exhaust air volume requirements; and required pressure capabilities of the fan(s). The more detailed information we receive the better solution we can propose for your individual request.

Start from pages 8 - 9 (quick selection). There you can choose from standard unit sizes. Optimal size depends on required capacity and maximum acceptable air speed.

On page 5 (standard modifications list) you can select a basic modification containing necessary elements. You will find more detailed information on the relevant page.

On the page with unit's description you'll find more detailed information about overall size, weight and optional elements.

On page 55 you'll find our inquiry form, which can help you to make a request.

STANDARD MODIFICATIONS LIST

Type of the unit	Function							Page	
Supply	<input checked="" type="checkbox"/>	<input checked="" type="checkbox"/>	<input checked="" type="checkbox"/>					<input checked="" type="checkbox"/>	12
	<input checked="" type="checkbox"/>	<input checked="" type="checkbox"/>		<input checked="" type="checkbox"/>				<input checked="" type="checkbox"/>	13
	<input checked="" type="checkbox"/>	<input checked="" type="checkbox"/>	<input checked="" type="checkbox"/>	<input checked="" type="checkbox"/>				<input checked="" type="checkbox"/>	14
	<input checked="" type="checkbox"/>	<input checked="" type="checkbox"/>	<input checked="" type="checkbox"/>	<input checked="" type="checkbox"/>				<input checked="" type="checkbox"/>	15
	<input checked="" type="checkbox"/>	<input checked="" type="checkbox"/>	<input checked="" type="checkbox"/>	<input checked="" type="checkbox"/>			<input checked="" type="checkbox"/>	<input checked="" type="checkbox"/>	10, 20, 22
Exhaust	<input checked="" type="checkbox"/>							<input checked="" type="checkbox"/>	10, 20
	<input checked="" type="checkbox"/>	<input checked="" type="checkbox"/>						<input checked="" type="checkbox"/>	11, 20
Exhaust and Supply	<input checked="" type="checkbox"/>	<input checked="" type="checkbox"/>			<input checked="" type="checkbox"/>			<input checked="" type="checkbox"/>	18, 20
	<input checked="" type="checkbox"/>	<input checked="" type="checkbox"/>				<input checked="" type="checkbox"/>		<input checked="" type="checkbox"/>	16, 20
	<input checked="" type="checkbox"/>	<input checked="" type="checkbox"/>					<input checked="" type="checkbox"/>	<input checked="" type="checkbox"/>	10, 20, 22
	<input checked="" type="checkbox"/>	<input checked="" type="checkbox"/>	<input checked="" type="checkbox"/>		<input checked="" type="checkbox"/>			<input checked="" type="checkbox"/>	18, 20, 21
	<input checked="" type="checkbox"/>	<input checked="" type="checkbox"/>	<input checked="" type="checkbox"/>			<input checked="" type="checkbox"/>		<input checked="" type="checkbox"/>	16, 20, 21
	<input checked="" type="checkbox"/>	<input checked="" type="checkbox"/>	<input checked="" type="checkbox"/>					<input checked="" type="checkbox"/>	10, 20, 21
	<input checked="" type="checkbox"/>	<input checked="" type="checkbox"/>		<input checked="" type="checkbox"/>	<input checked="" type="checkbox"/>			<input checked="" type="checkbox"/>	18, 20, 21
	<input checked="" type="checkbox"/>	<input checked="" type="checkbox"/>		<input checked="" type="checkbox"/>		<input checked="" type="checkbox"/>		<input checked="" type="checkbox"/>	16, 20, 21
	<input checked="" type="checkbox"/>	<input checked="" type="checkbox"/>	<input checked="" type="checkbox"/>	<input checked="" type="checkbox"/>	<input checked="" type="checkbox"/>		<input checked="" type="checkbox"/>	<input checked="" type="checkbox"/>	16, 20, 21
	<input checked="" type="checkbox"/>	<input checked="" type="checkbox"/>	<input checked="" type="checkbox"/>	<input checked="" type="checkbox"/>		<input checked="" type="checkbox"/>		<input checked="" type="checkbox"/>	18, 20, 21
	<input checked="" type="checkbox"/>	<input checked="" type="checkbox"/>	<input checked="" type="checkbox"/>	<input checked="" type="checkbox"/>	<input checked="" type="checkbox"/>	<input checked="" type="checkbox"/>		<input checked="" type="checkbox"/>	16, 20, 21, 22
	<input checked="" type="checkbox"/>	<input checked="" type="checkbox"/>	<input checked="" type="checkbox"/>	<input checked="" type="checkbox"/>		<input checked="" type="checkbox"/>		<input checked="" type="checkbox"/>	18, 20, 21
	<input checked="" type="checkbox"/>	<input checked="" type="checkbox"/>	<input checked="" type="checkbox"/>	<input checked="" type="checkbox"/>				<input checked="" type="checkbox"/>	10, 20, 21
	<input checked="" type="checkbox"/>	<input checked="" type="checkbox"/>	<input checked="" type="checkbox"/>	<input checked="" type="checkbox"/>	<input checked="" type="checkbox"/>		<input checked="" type="checkbox"/>	<input checked="" type="checkbox"/>	16, 20, 21, 22
<input checked="" type="checkbox"/>	<input checked="" type="checkbox"/>	<input checked="" type="checkbox"/>	<input checked="" type="checkbox"/>		<input checked="" type="checkbox"/>		<input checked="" type="checkbox"/>	18, 20, 21, 22	

- Fan
- Plate heat exchanger
- Filter
- Rotary heat exchanger
- Heater
- Humidification
- Cooling section
- Silencer

UNIT DESIGNATION

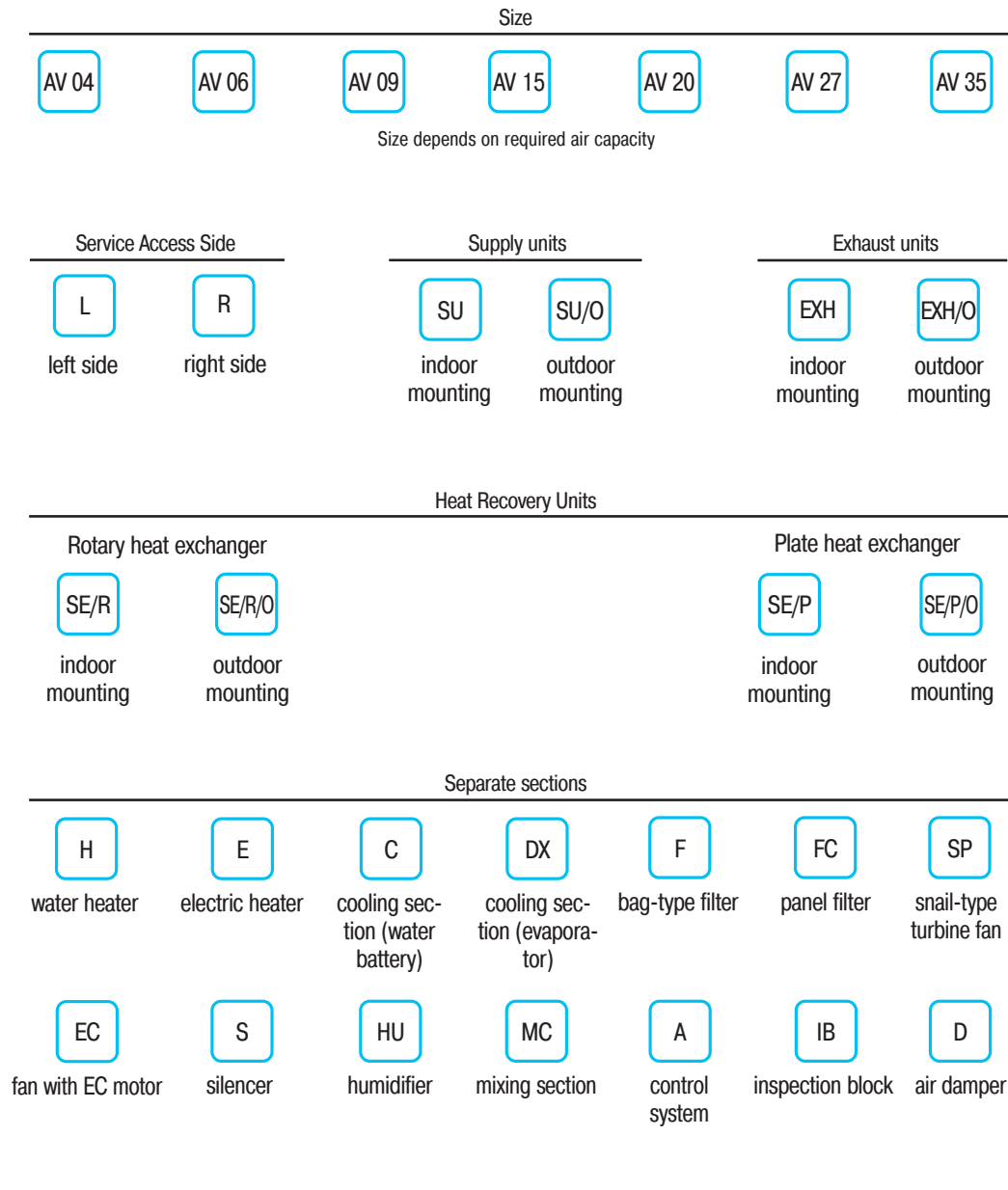

Unit's designation example

AV 09L/SE/P/OHCS

A heat recovery unit for outdoor mounting equipped with air-to-air plate heat recovery section and silencer with total air capacity of 9000 m³/h. Service access side: left.

AV 15R/SU/OFCEDSA

Air supply unit for outdoor mounting equipped with a panel filter, electric heater, refrigerant cooling section and silencer supplied with control system. Total capacity: 15000 m³/h. Service access side: right.

SERVICE ACCESS SIDE

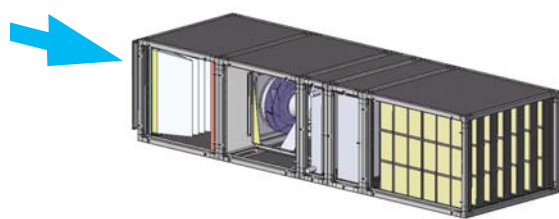

RIGHT

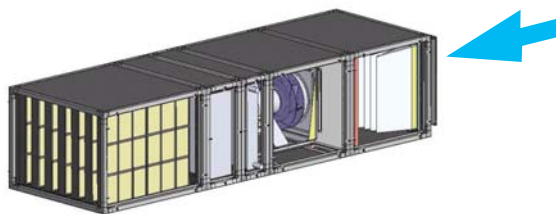

LEFT

All units can be manufactured in left or right access side versions. Access side specifies the position of access doors, connecting pipes of heat exchangers and drain pipes for condensed water.

-right access side is placed at the right of air flow direction line

-left side is placed at the left of air flow direction line

QUICK SELECTION

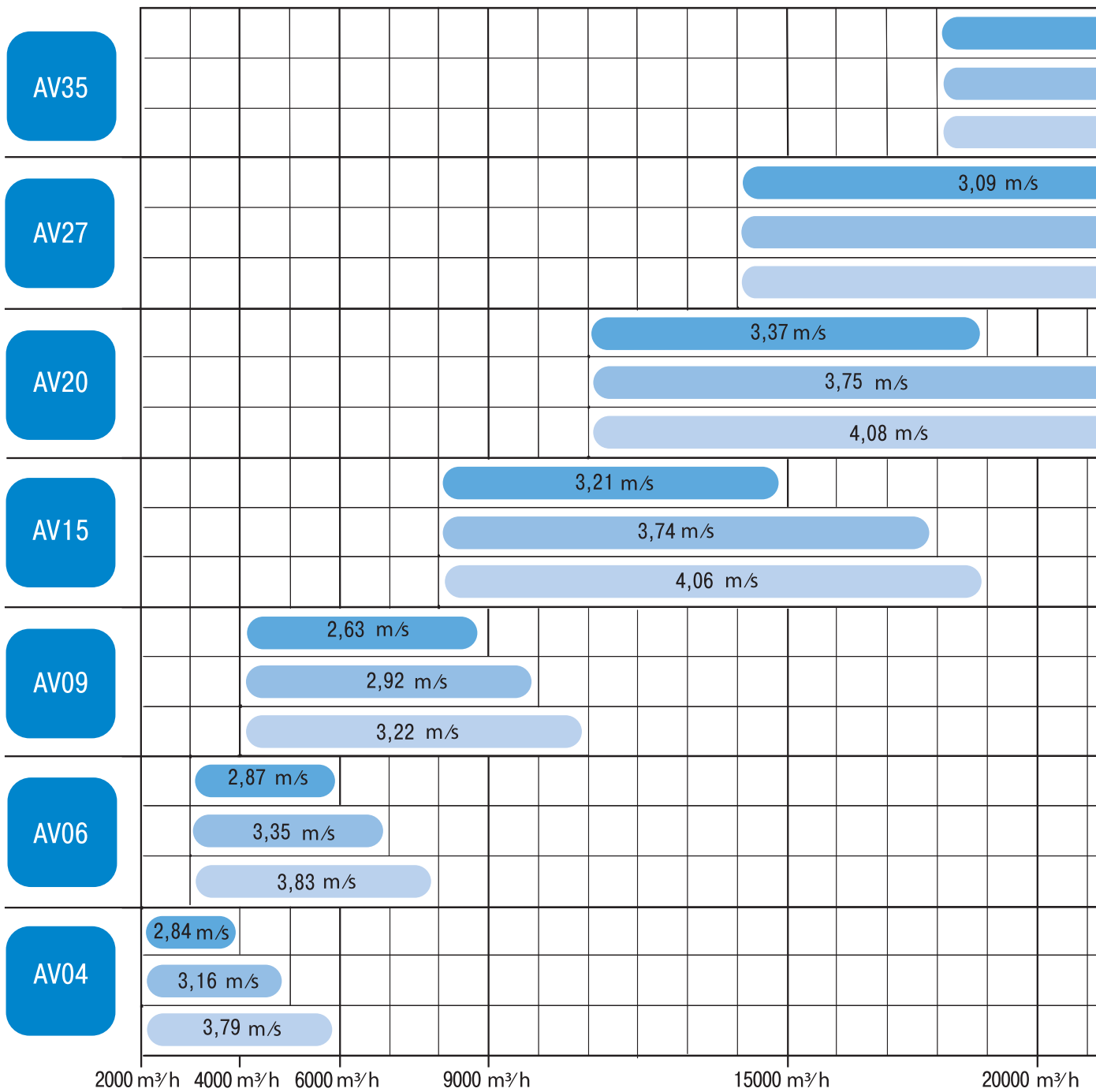

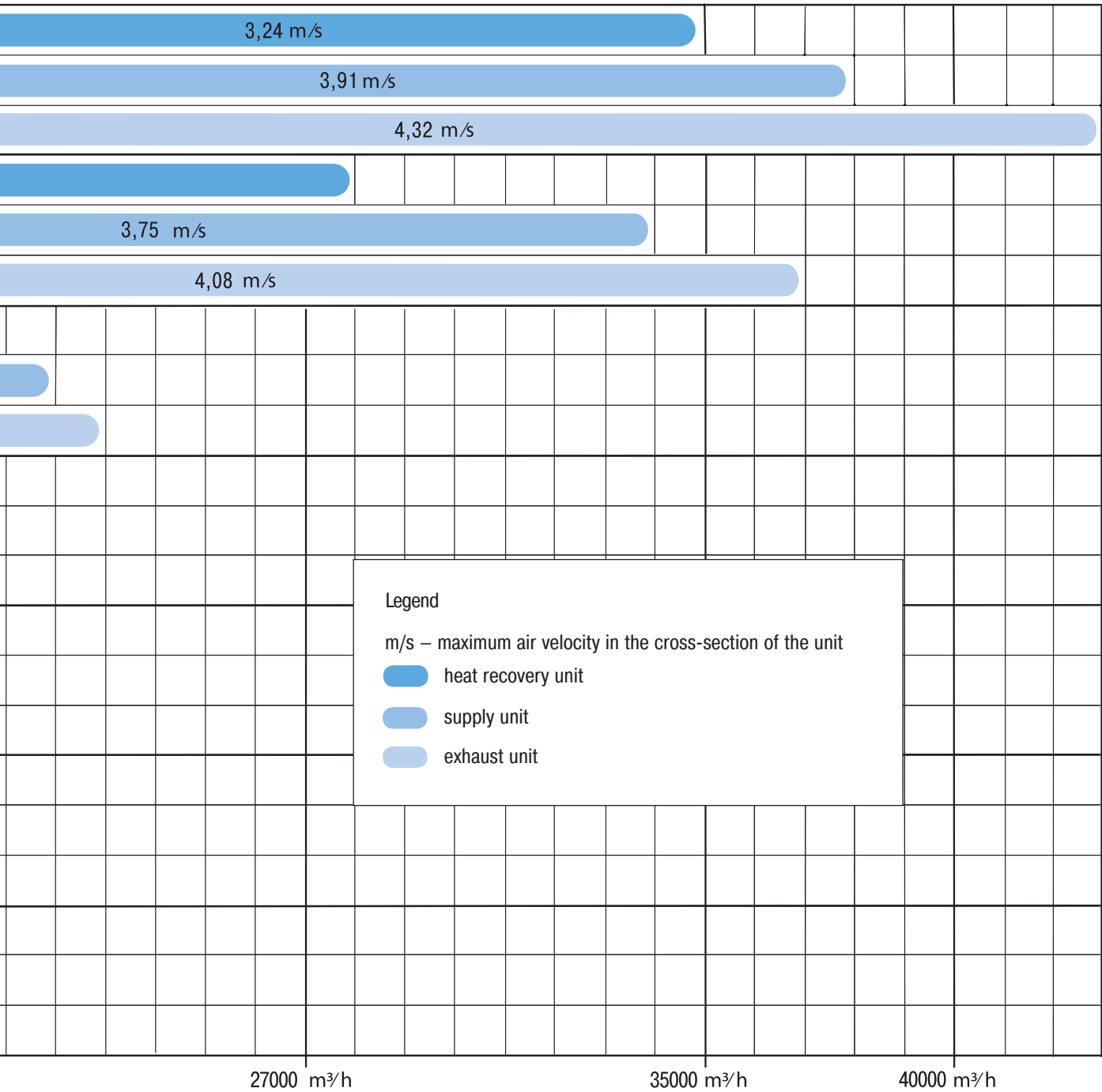

EXHAUST UNITS



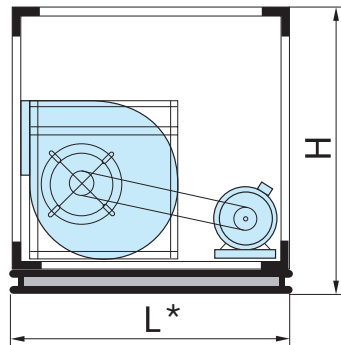
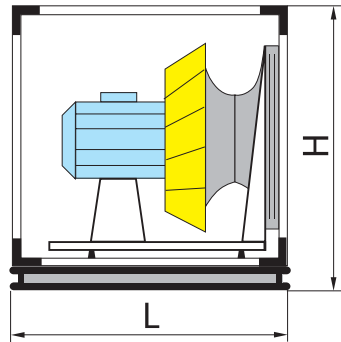

Exhaust fan

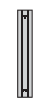

OPTIONAL ELEMENTS

-  - air damper
-  - flexible connection

OPTIONAL FUNCTIONAL SECTIONS

-  **S** silencer
-  **F** filter
-  **MC** mixing section
-  **IB** inspection block

(see description on page 20-23)

Type	length, L [m]	length, L* [m]	height, H [m]	width, W [m]	inlet size, A*B [m]	weight [kg]
AV 04	0,8	1,21	0,73	0,87	0,7 x 0,4	85-94
AV 06	0,9	1,26	0,81	0,98	0,8 x 0,5	100-120
AV 09	1,13	1,24	0,97	1,3	1 x 0,5	110-131
AV 15	1,13	1,43	1,16	1,43	1,2 x 0,9	142-163
AV 20	1,13	1,13	1,26	1,63	1,4 x 1	180-200
AV 27	1,13	1,13	1,34	2,27	2 x 1	250-320
AV 35	1,13	1,13	1,42	2,27	1,2 x 2,1	280-360

Size: AV 04 AV 06 AV 09 AV 15 AV 20 AV 27 AV 35

service access side: L R
L – left, R – right

supply units: SU SU/O
SU – indoor mounting, SU/O – outdoor mounting

exhaust units: EXH EXH/O
EXH – indoor mounting, EXH/O – outdoor mounting

exhaust and supply units: SE SE/O
SE – indoor mounting, SE/O – outdoor mounting

Rotary heat exchanger: SE/R SE/R/O
SE/R – indoor mounting, SE/R/O – outdoor mounting

Plate heat exchanger: SE/P SE/P/O
SE/P – indoor mounting, SE/P/O – outdoor mounting

Exhaust fan and filter

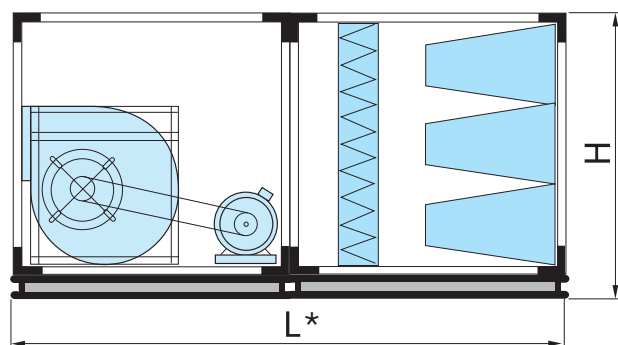
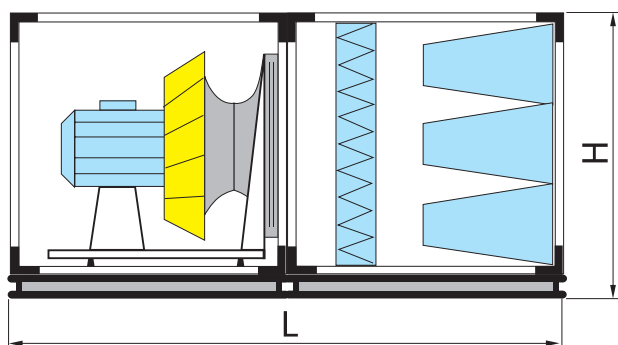

OPTIONAL ELEMENTS

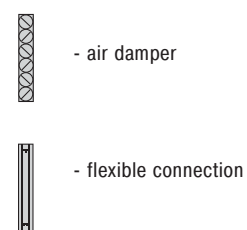

OPTIONAL FUNCTIONAL SECTIONS

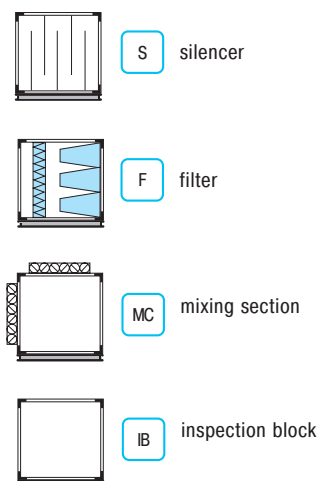

(see description on page 20-23)

Type	length, L [m]	length, L* [m]	height, H [m]	width, W [m]	inlet size, A*B [m]	weight [kg]
AV 04	1,6	2,01	0,73	0,87	0,7 x 0,4	125-134
AV 06	1,8	2,16	0,81	0,98	0,8 x 0,5	150-170
AV 09	2,26	2,37	0,97	1,3	1 x 0,5	160-191
AV 15	2,26	2,56	1,16	1,43	1,2 x 0,9	187-213
AV 20	2,26	2,26	1,26	1,63	1,4 x 1	230-270
AV 27	2,26	2,26	1,34	2,27	2 x 1	325-410
AV 35	2,26	2,26	1,42	2,27	2,1 x 1,2	390-470

Separate sections

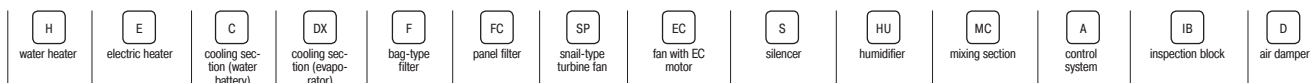

SUPPLY UNITS

Supply fan with filter and heater

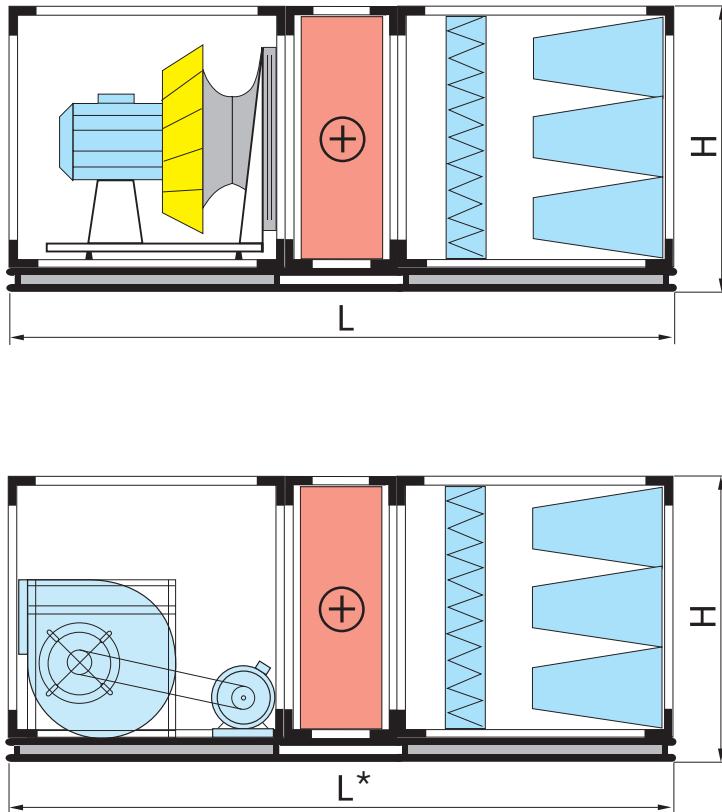

OPTIONAL ELEMENTS

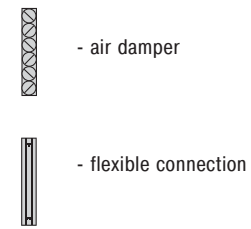

OPTIONAL FUNCTIONAL SECTIONS

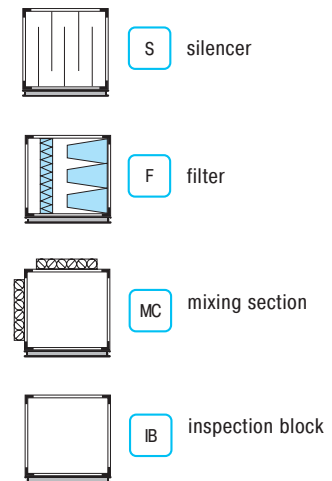

(see description on page 20-23)

Type	length, L [m]	length, L* [m]	height, H [m]	width, W [m]	inlet size, A*B [m]	weight [kg]
AV 04	1,95	2,36	0,73	0,87	0,7 x 0,4	155-164
AV 06	2,19	2,55	0,81	0,98	0,8 x 0,5	182-202
AV 09	2,65	2,87	0,97	1,3	1 x 0,5	205-236
AV 15	2,65	3,25	1,16	1,43	1,2 x 0,9	252-278
AV 20	2,65	2,65	1,26	1,63	1,4 x 1	310-350
AV 27	2,65	2,65	1,34	2,27	2 x 1	415-500
AV 35	2,65	2,65	1,42	2,27	2,1 x 1,2	490-580

Supply fan with filter and cooling section

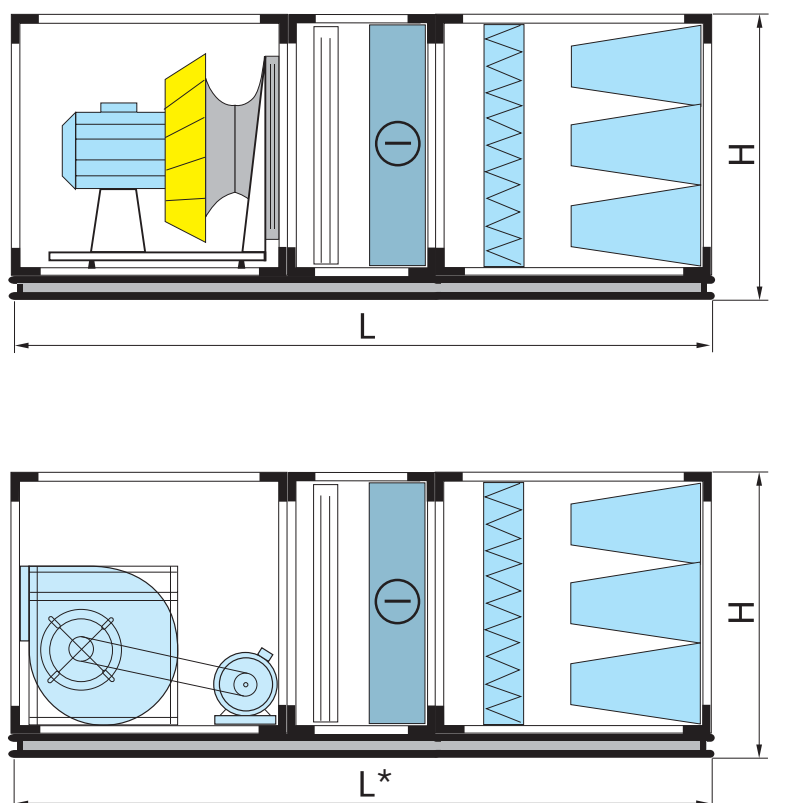

OPTIONAL ELEMENTS

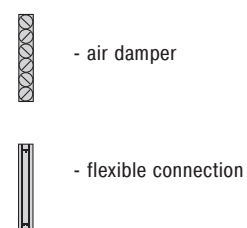

OPTIONAL FUNCTIONAL SECTIONS

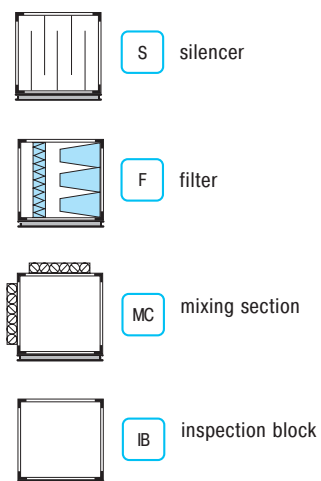

(see description on page 20-23)

Type	length, L [m]	length, L* [m]	height, H [m]	width, W [m]	inlet size, A*B [m]	weight [kg]
AV 04	2,11	2,52	0,73	0,87	0,7 x 0,4	165-174
AV 06	2,31	2,67	0,81	0,98	0,8 x 0,5	197-217
AV 09	2,79	3,01	0,97	1,3	1 x 0,5	225-256
AV 15	2,75	3,35	1,16	1,43	1,2 x 0,9	282-308
AV 20	2,75	2,75	1,26	1,63	1,4 x 1	360-400
AV 27	2,89	2,89	1,34	2,27	2 x 1	485-570
AV 35	2,89	2,89	1,42	2,27	2,1 x 2	570-640

Separate sections

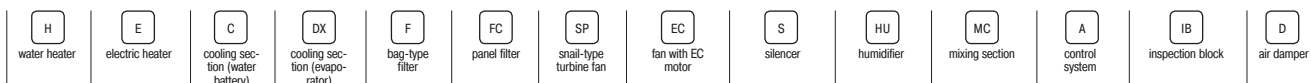

SUPPLY UNITS

Supply fan with filter, heating and cooling section

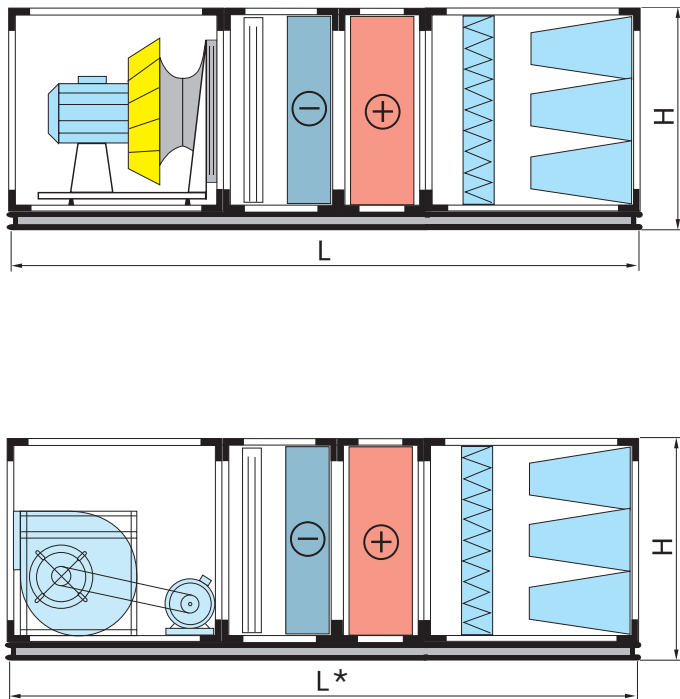

OPTIONAL ELEMENTS

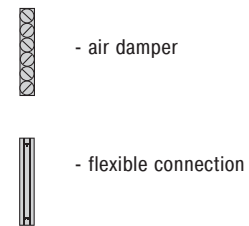

OPTIONAL FUNCTIONAL SECTIONS

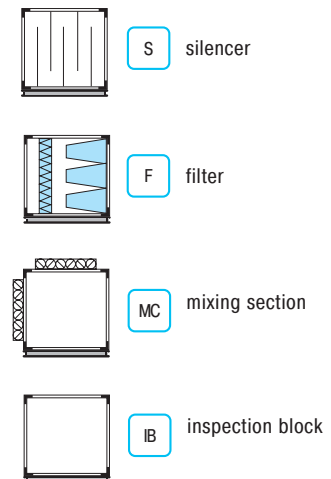

(see description on page 20-23)

Type	length, L [m]	length, L* [m]	height, H [m]	width, W [m]	inlet size, A*B [m]	weight [kg]
AV 04	2,46	2,87	0,73	0,87	0,7 x 0,4	195-204
AV 06	2,7	3,06	0,81	0,98	0,8 x 0,5	229-249
AV 09	3,18	3,4	0,97	1,3	1 x 0,5	270-301
AV 15	3,14	3,74	1,16	1,43	1,2 x 0,9	347-373
AV 20	3,14	3,14	1,26	1,63	1,4 x 1	420-480
AV 27	3,28	3,28	1,34	2,27	2 x 1	575-660
AV 35	3,28	3,28	1,42	2,27	2,1 x 2	670-750

Supply fan with filter, two heaters and cooling section

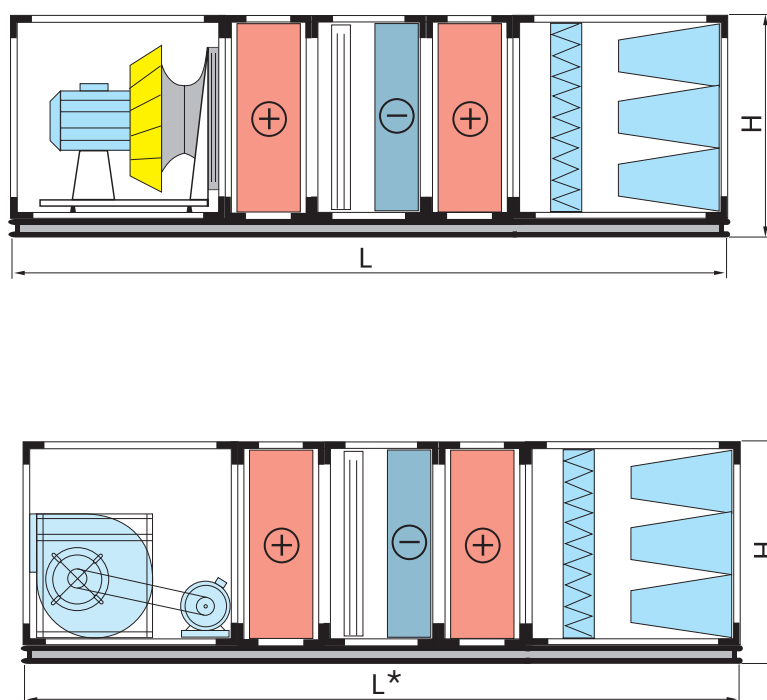

OPTIONAL ELEMENTS

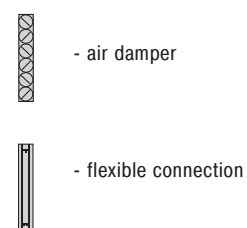

OPTIONAL FUNCTIONAL SECTIONS

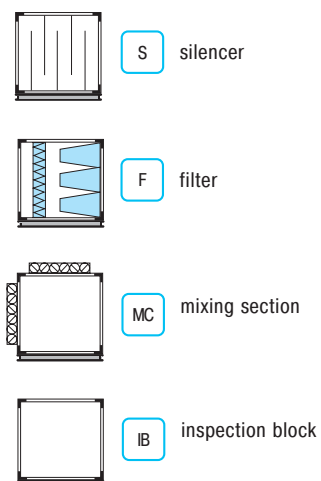

(see description on page 20-23)

Type	length, L [m]	length, L* [m]	height, H [m]	width, W [m]	inlet size, A*B [m]	weight [kg]
AV 04	2,97	3,38	0,73	0,87	0,7 x 0,4	225-234
AV 06	3,21	3,57	0,81	0,98	0,8 x 0,5	261-281
AV 09	3,71	3,93	0,97	1,3	1 x 0,5	315-346
AV 15	3,63	4,23	1,16	1,43	1,2 x 0,9	412-438
AV 20	3,63	3,63	1,26	1,63	1,4 x 1	500-560
AV 27	3,91	3,91	1,34	2,27	2 x 1	665-750
AV 35	3,91	3,91	1,42	2,27	2,1 x 2	770-860

Separate sections

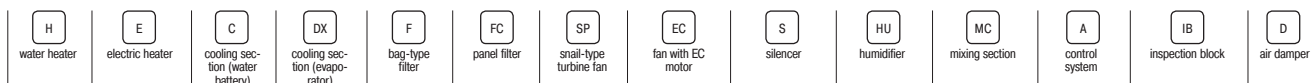

ROTARY HEAT RECOVERY UNITS

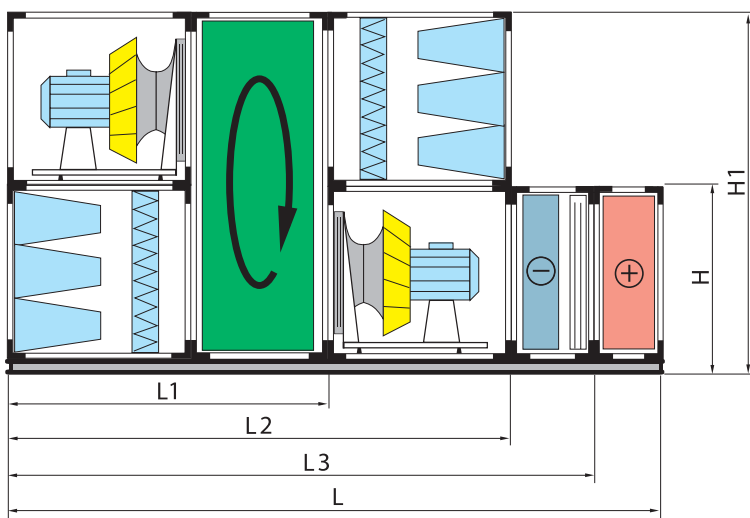

OPTIONAL ELEMENTS

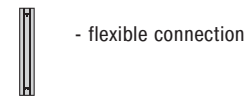

OPTIONAL FUNCTIONAL SECTIONS

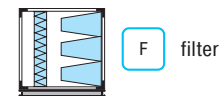
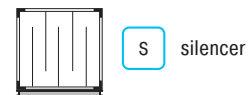



(see description on page 20-23)

Type	length, L1 [m]	length, L2 [m]	length, L3 [m]	length, L [m]	height, H [m]	height, H1 [m]	width, W [m]	inlet size, A*B [m]	weight [kg]
AV 04	1,39	2,19	2,54	3,05	0,73	1,33	1,2	0,7 x 0,4	480-500
AV 06	1,49	2,39	2,78	3,29	0,81	1,48	1,35	0,8 x 0,5	625-665
AV 09	1,72	2,85	3,24	3,77	0,97	1,86	1,73	1 x 0,5	644-696
AV 15	1,75	2,88	3,27	3,76	1,16	2,24	2,11	1,2 x 0,9	834-886
AV 20	1,75	2,88	3,27	3,76	1,26	2,44	2,31	1,4 x 1	1016-1116
AV 27	1,82	2,95	3,34	3,97	1,34	2,61	2,47	2 x 1	1310-1480
AV 35	1,72	2,85	3,24	3,87	1,42	2,77	2,64	2 x 1,2	1516-1676

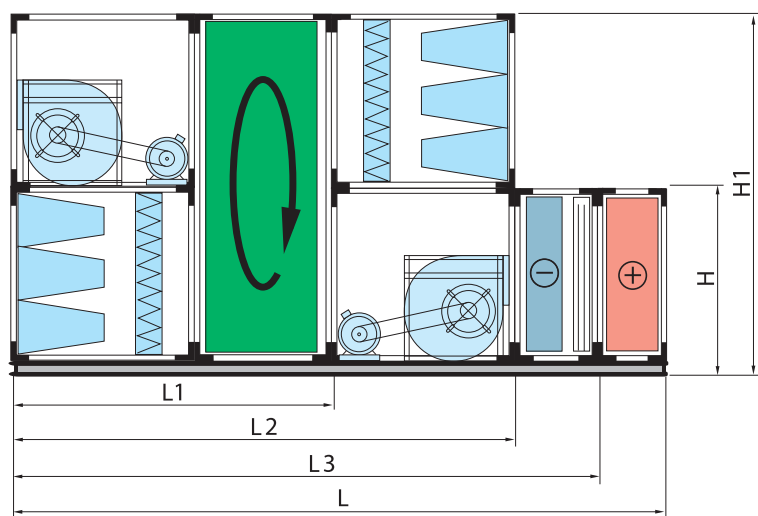



Size: AV 04 AV 06 AV 09 AV 15 AV 20 AV 27 AV 35
 service access side: L R (L - left, R - right)
 supply units: SU SU/O (SU - indoor mounting, SU/O - outdoor mounting)
 exhaust units: EXH EXH/O (EXH - indoor mounting, EXH/O - outdoor mounting)
 exhaust and supply units: SE SE/O (SE - indoor mounting, SE/O - outdoor mounting)
 Rotary heat exchanger: SE/R SE/R/O (SE/R - indoor mounting, SE/R/O - outdoor mounting)
 Plate heat exchanger: SE/P SE/P/O (SE/P - indoor mounting, SE/P/O - outdoor mounting)



OPTIONAL ELEMENTS

-  - air damper
-  - flexible connection















OPTIONAL FUNCTIONAL SECTIONS

-  S silencer
-  F filter
-  MC mixing section
-  IB inspection block

(see description on page 20-23)

Type	length, L1 [m]	length, L2 [m]	length, L3 [m]	length, L [m]	height, H [m]	height, H1 [m]	width, W [m]	inlet size, A*B [m]	weight [kg]
AV 04	1,8	2,6	2,95	3,46	0,73	1,33	1,2	0,7 x 0,4	480-500
AV 06	1,85	2,75	3,14	3,65	0,81	1,48	1,35	0,8 x 0,5	625-665
AV 09	1,83	3,07	3,46	3,99	0,97	1,86	1,73	1 x 0,5	644-696
AV 15	2,05	3,48	3,87	4,36	1,16	2,24	2,11	1,2 x 0,9	834-886
AV 20	1,75	2,88	3,27	3,76	1,26	2,44	2,31	1,4 x 1	1016-1116
AV 27	1,82	2,95	3,34	3,97	1,34	2,61	2,47	2 x 1	1310-1480
AV 35	1,72	2,85	3,24	3,87	1,42	2,77	2,64	2 x 1,2	1516-1676

Separate sections

-  water heater
-  electric heater
-  cooling section (water battery)
-  cooling section (evaporator)
-  bag-type filter
-  panel filter
-  snail-type turbine fan
-  fan with EC motor
-  silencer
-  humidifier
-  mixing section
-  control system
-  inspection block
-  air damper

HEAT RECOVERY UNITS WITH PLATE HEAT EXCHANGER

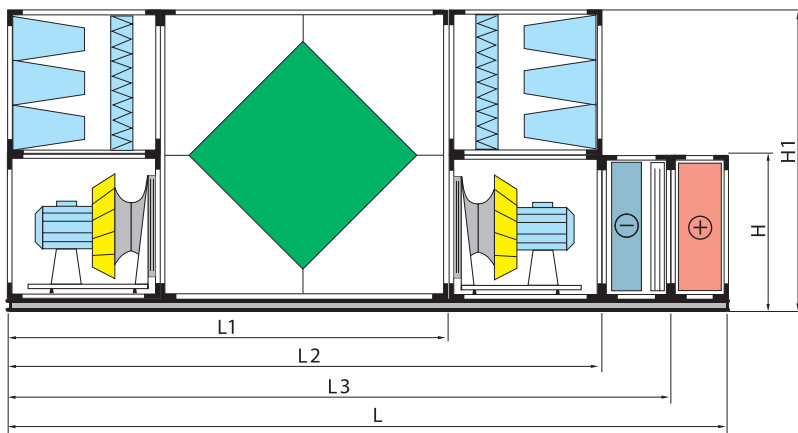

OPTIONAL ELEMENTS

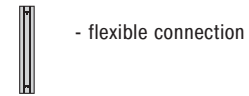
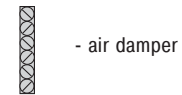

OPTIONAL FUNCTIONAL SECTIONS

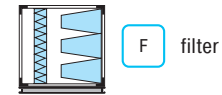
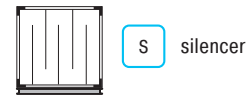



(see description on page 20-23)

Type	length, L1 [m]	length, L2 [m]	length, L3 [m]	length, L [m]	height, H [m]	height, H1 [m]	width, W [m]	inlet size, A*B [m]	weight [kg]
AV 04	2,05	2,85	3,2	3,71	0,73	1,33	0,87	0,7 x 0,4	506-526
AV 06	2,30	3,20	3,59	4,1	0,81	1,48	0,98	0,8 x 0,5	619-659
AV 09	2,73	3,86	4,35	4,78	0,97	1,86	1,3	1 x 0,5	668-720
AV 15	3,28	4,41	4,8	5,29	1,16	2,24	1,43	1,2 x 0,9	826-878
AV 20	3,28	4,41	4,8	5,29	1,26	2,44	1,63	1,4 x 1	1030-1130
AV 27	3,28	4,41	4,8	5,43	1,34	2,61	2,27	2 x 1	1426-1596
AV 35	3,81	4,94	5,33	5,96	1,42	2,77	2,27	2,1 x 2	1679-1839

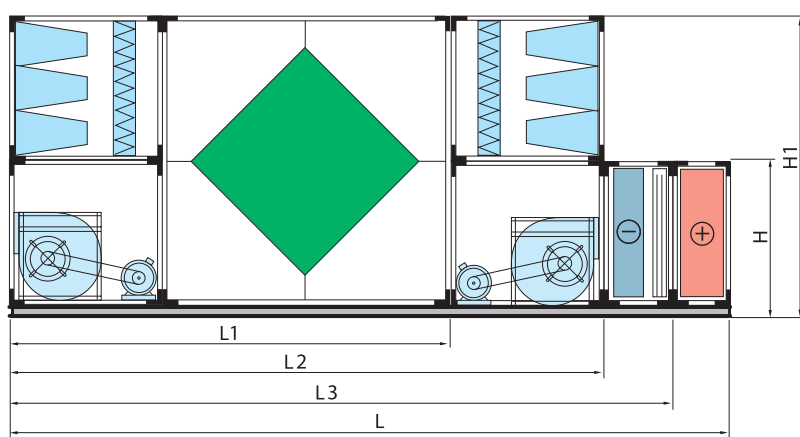



Size	AV 04	AV 06	AV 09	service access side	L	R	supply units	SU	SU/O	exhaust units	EXH	EXH/O	exhaust and supply units	SE	SE/O	Rotary heat exchanger	SE/R	SE/R/O	Plate heat exchanger	SE/P	SE/P/O
	AV 15	AV 20	AV 27		L - left	R - right		SU - indoor mounting	SU/O - outdoor mounting		EXH - indoor mounting	EXH/O - outdoor mounting		SE - indoor mounting	SE/O - outdoor mounting		SE/R - indoor mounting	SE/R/O - outdoor mounting		SE/P - indoor mounting	SE/P/O - outdoor mounting



OPTIONAL ELEMENTS

-  - air damper
-  - flexible connection















OPTIONAL FUNCTIONAL SECTIONS

-  S silencer
-  F filter
-  MC mixing section
-  IB inspection block

(see description on page 20-23)

Type	length, L1 [m]	length, L2 [m]	length, L3 [m]	length, L [m]	height, H [m]	height, H1 [m]	width, W [m]	inlet size, A*B [m]	weight [kg]
AV 04	2,41	3,62	3,97	4,48	0,73	1,33	0,87	0,7 x 0,4	506-526
AV 06	2,66	3,92	4,31	4,82	0,81	1,48	0,98	0,8 x 0,5	619-659
AV 09	2,84	3,97	4,36	4,89	0,97	1,86	1,3	1 x 0,5	668-720
AV 15	3,58	4,71	5,1	5,59	1,16	2,24	1,43	1,2 x 0,9	826-878
AV 20	3,28	4,41	4,8	5,29	1,26	2,44	1,63	1,4 x 1	1030-1130
AV 27	3,28	4,41	4,8	5,43	1,34	2,61	2,27	2 x 1	1426-1596
AV 35	3,81	4,94	5,33	5,96	1,42	2,77	2,27	2,1 x 2	1679-1839

Separate sections

-  H water heater
-  E electric heater
-  C cooling section (water battery)
-  DX cooling section (evaporator)
-  F bag-type filter
-  FC panel filter
-  SP snail-type turbine fan
-  EC fan with EC motor
-  S silencer
-  HU humidifier
-  MC mixing section
-  A control system
-  IB inspection block
-  D air damper

SEPARATE SECTIONS

Silencer section

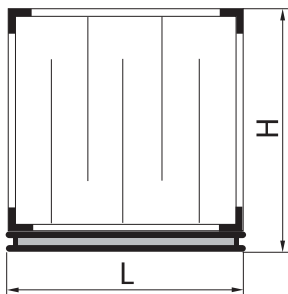

Type	length, L [m]	height, H [m]	width, W [m]	weight [kg]
AV 04	1,44	0,73	0,87	90
AV 06	1,44	0,81	0,98	110
AV 09	1,44	0,97	1,3	120
AV 15	1,44	1,16	1,43	150
AV 20	1,44	1,26	1,63	190
AV 27	1,44	1,34	2,27	290
AV 35	1,44	1,42	2,27	320

Filter section

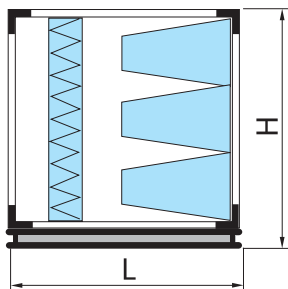

Type	length, L [m]	height, H [m]	width, W [m]	inlet size, A*B [m]	weight [kg]
AV 04	0,8	0,73	0,87	0,7x0,4	40-45
AV 06	0,9	0,81	0,98	0,8x0,5	50-60
AV 09	1,13	0,97	1,3	1,0x0,5	70
AV 15	1,13	1,16	1,43	1,2x0,9	80
AV 20	1,13	1,26	1,63	1,4x1	110
AV 27	1,13	1,34	2,27	2x1	160
AV 35	1,13	1,42	2,27	2,1x1,2	180

Mixing section

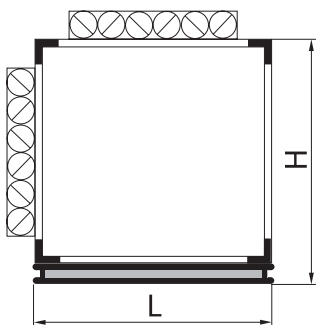

Type	length, L [m]	height, H [m]	width, W [m]	inlet size, A*B [m]	weight [kg]
AV 04	0,81	0,73	0,87	0,7x0,4	50
AV 06	0,9	0,81	0,98	0,8x0,5	62
AV 09	1,13	0,97	1,3	1,0x0,5	80
AV 15	1,13	1,16	1,43	1,2x0,9	100
AV 20	1,13	1,26	1,63	1,4x1	130
AV 27	1,13	1,34	2,27	2x1	180
AV 35	1,13	1,42	2,27	2,1x1,2	220

Empty (inspection) section

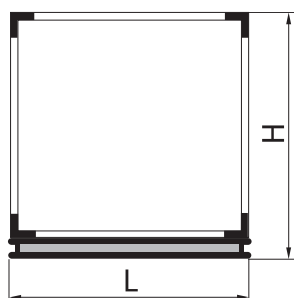

Type	length, L [m]	height, H [m]	width, W [m]	weight [kg]
AV 04	0,81	0,73	0,87	40
AV 06	0,9	0,81	0,98	50
AV 09	1,13	0,97	1,3	65
AV 15	1,13	1,16	1,43	80
AV 20	1,13	1,26	1,63	100
AV 27	1,13	1,34	2,27	140
AV 35	1,13	1,42	2,27	170

Heater section (electric or water)

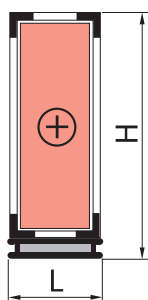

Type	length, L [m]	height, H [m]	width, W [m]	weight [kg]
AV 04	0,35	0,73	0,87	30
AV 06	0,39	0,81	0,98	32
AV 09	0,39	0,97	1,3	45
AV 15	0,39	1,16	1,43	65
AV 20	0,39	1,26	1,63	80
AV 27	0,39	1,34	2,27	90
AV 35	0,39	1,42	2,27	100

Cooling section (water battery or evaporator)

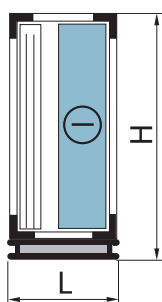

Type	length, L [m]	height, H [m]	width, W [m]	weight [kg]
AV 04	0,51	0,73	0,87	40
AV 06	0,51	0,81	0,98	47
AV 09	0,53	0,97	1,3	65
AV 15	0,49	1,16	1,43	95
AV 20	0,49	1,26	1,63	130
AV 27	0,63	1,34	2,27	160
AV 35	0,63	1,42	2,27	180

Separate sections

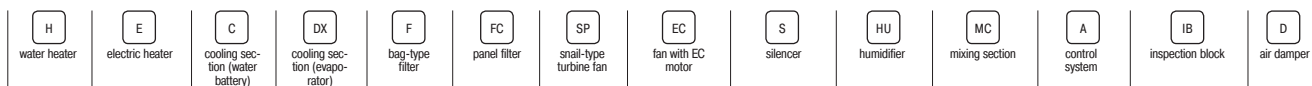

SEPARATE SECTIONS

Plate heat recovery section

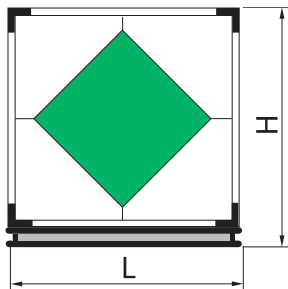

Type	length, L [m]	height, H [m]	width, W [m]	weight [kg]
AV 04	1,2	1,33	0,87	108
AV 06	1,4	1,48	0,98	125
AV 09	1,6	1,86	1,3	170
AV 15	2,15	2,24	1,43	230
AV 20	2,15	2,44	1,63	280
AV 27	2,15	2,65	2,27	420
AV 35	2,68	2,77	2,27	550

Rotary heat recovery section

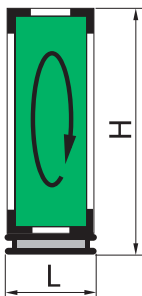

Type	length, L [m]	height, H [m]	width, W [m]	weight [kg]
AV 04	0,59	1,33	1,2	155
AV 06	0,59	1,48	1,35	210
AV 09	0,59	1,86	1,73	260
AV 15	0,62	2,24	2,11	380
AV 20	0,62	2,44	2,31	445
AV 27	0,69	2,65	2,47	530
AV 35	0,59	2,77	2,64	620

Humidifier section

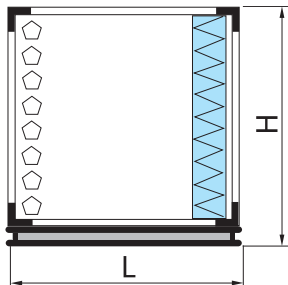

Type	length, L [m]	height, H [m]	width, W [m]	weight [kg]
AV 04	1,2	1,33	0,87	108
AV 06	1,4	1,48	0,98	125
AV 09	1,6	1,86	1,3	170
AV 15	2,15	2,24	1,43	230
AV 20	2,15	2,44	1,63	280
AV 27	2,15	2,65	2,27	420
AV 35	2,68	2,77	2,27	550

Air damper

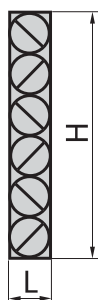

Type	length, L [m]	height, H [m]	width, W [m]	inlet size, A*B [m]	weight [kg]
AV 04	0,17	0,4	0,7	0,7x0,4	5
AV 06	0,17	0,5	0,8	0,8x0,5	6
AV 09	0,17	0,5	1	1,0x0,5	7,5
AV 15	0,17	0,9	1,2	1,2x0,9	10

two-section type

AV 20	0,17	0,5	1,4	1,4x1	15x2
AV 27	0,17	1	1	2x1	20x2
AV 35	0,17	1,2	1,05	2,1x1,2	25x2

Flexible connection

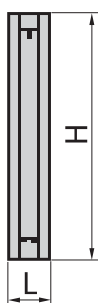

Type	length, L [m]	height, H [m]	width, W [m]	inlet size, A*B [m]	weight [kg]
AV 04	0,17	0,44	0,74	0,7x0,4	0,8
AV 06	0,17	0,54	0,84	0,8x0,5	1,1
AV 09	0,17	0,54	1,04	1,0x0,5	1,4
AV 15	0,17	0,94	1,24	1,2x0,9	1,6

two-section type

AV 20	0,17	0,54	1,44	1,4x1	2,9
AV 27	0,17	1,04	1,04	2x1	4,1
AV 35	0,17	1,24	1,09	2,1x1,2	5,5

Separate sections

H water heater	E electric heater	C cooling section (water battery)	DX cooling section (evaporator)	F bag-type filter	FC panel filter	SP snail-type turbine fan	EC fan with EC motor	S silencer	HU humidifier	MC mixing section	A control system	IB inspection block	D air damper
--------------------------	-----------------------------	---	---	-----------------------------	---------------------------	-------------------------------------	--------------------------------	----------------------	-------------------------	-----------------------------	----------------------------	-------------------------------	------------------------

FAN CURVES (AV 04)

350 mm

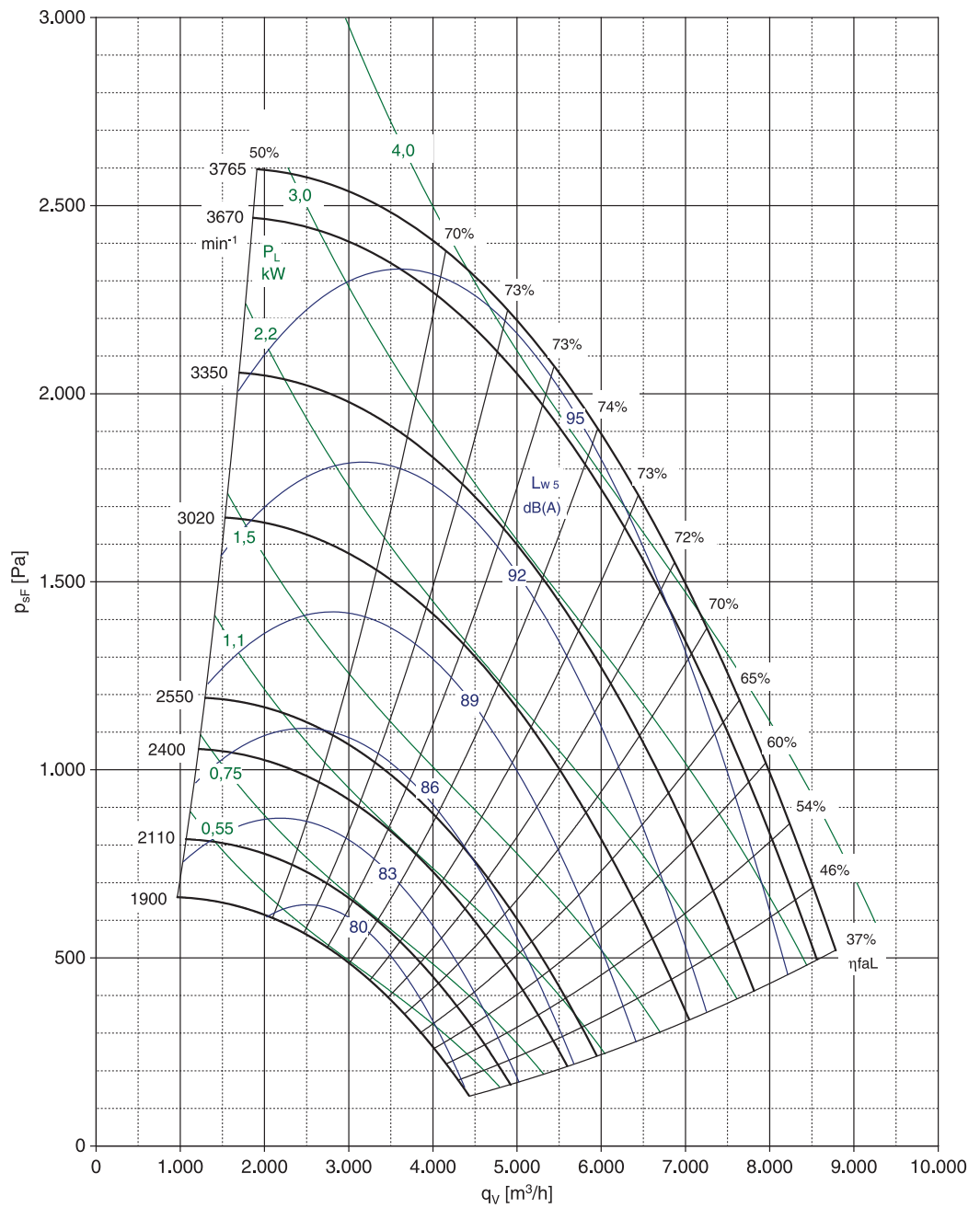
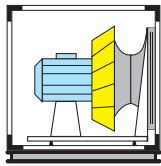

225 mm

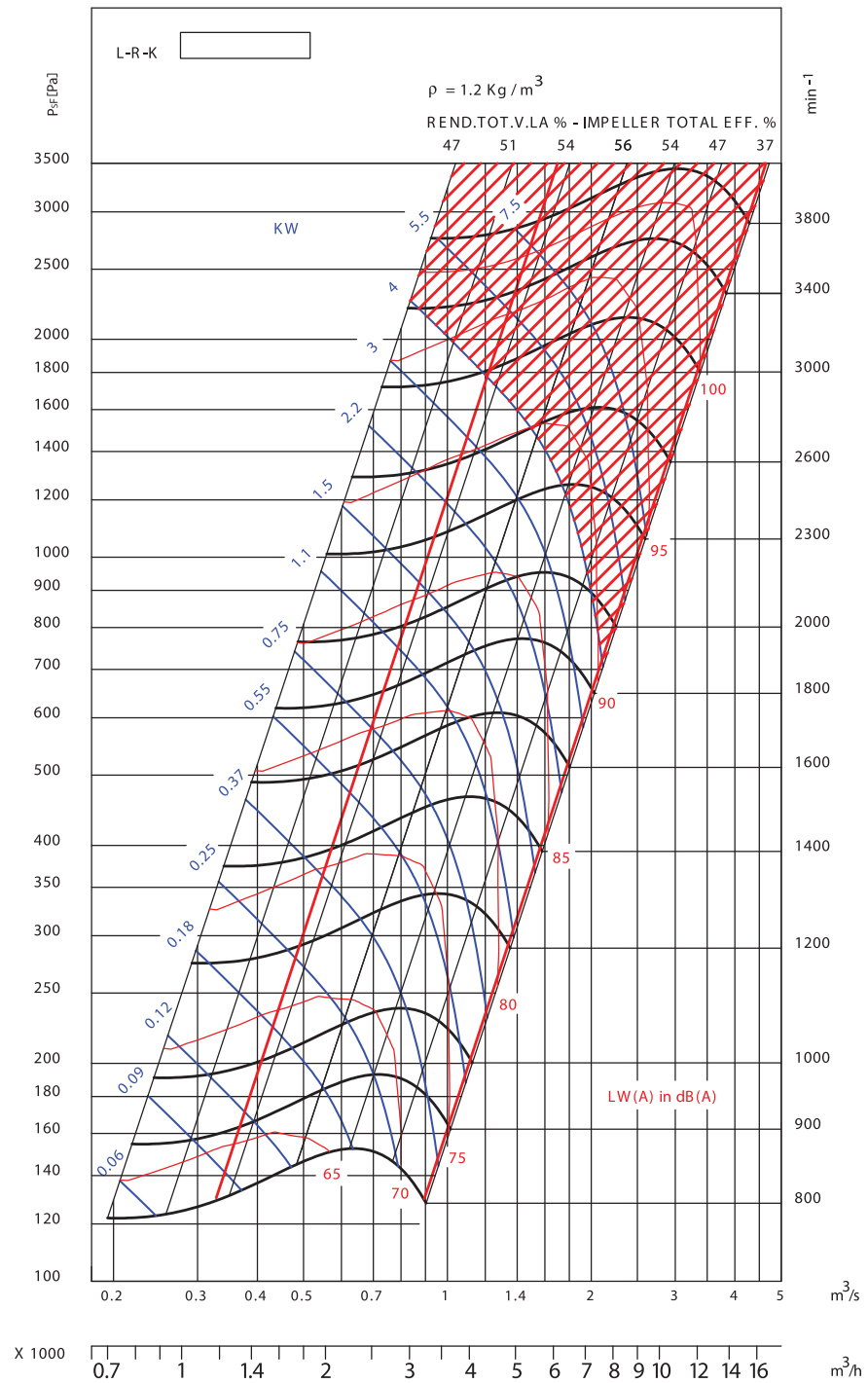
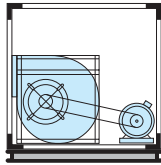

FAN CURVES (AV 06)

400 mm

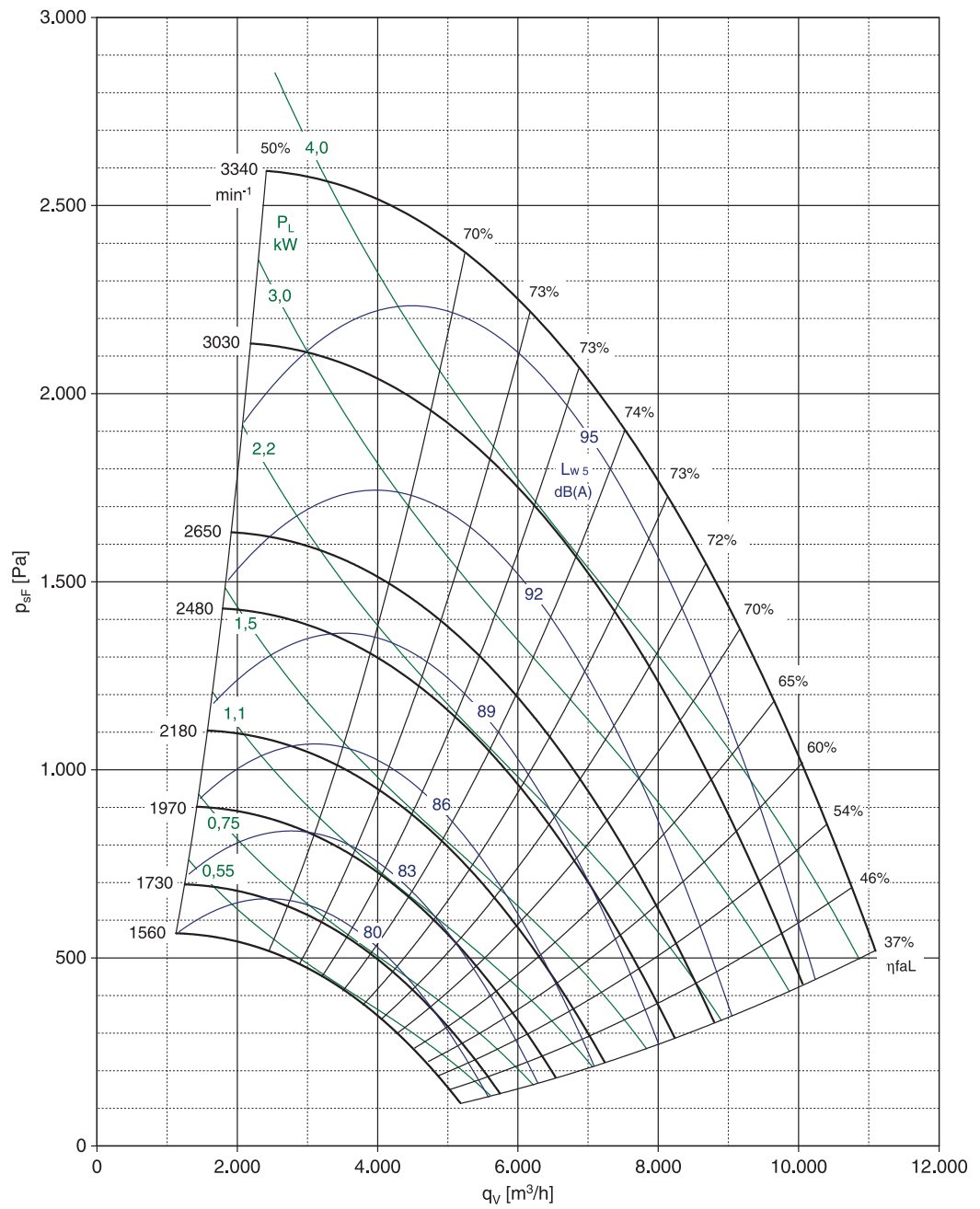
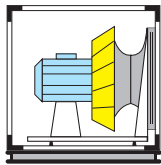

250 mm

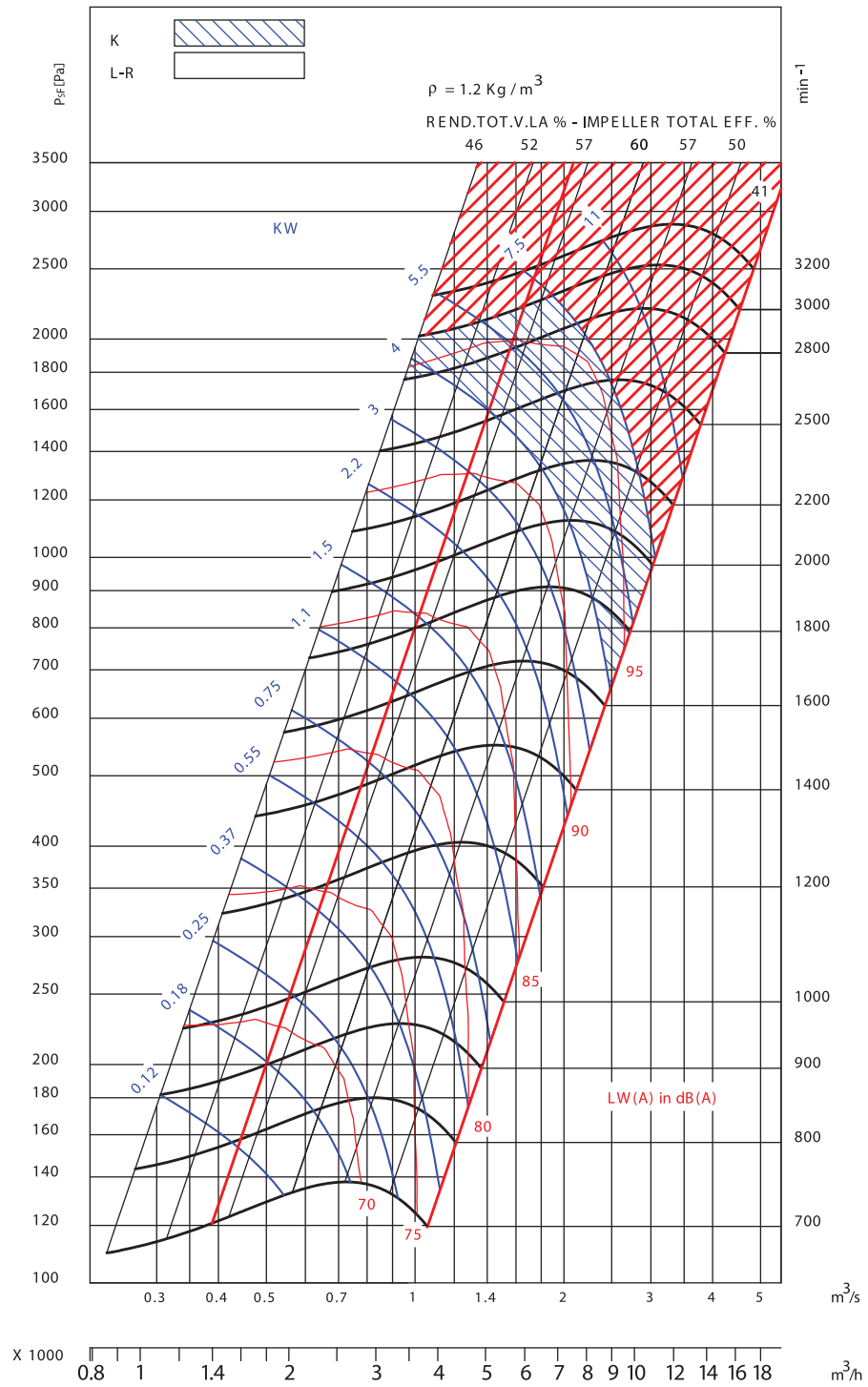
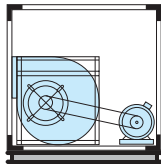

FAN CURVES (AV 09)

450 mm

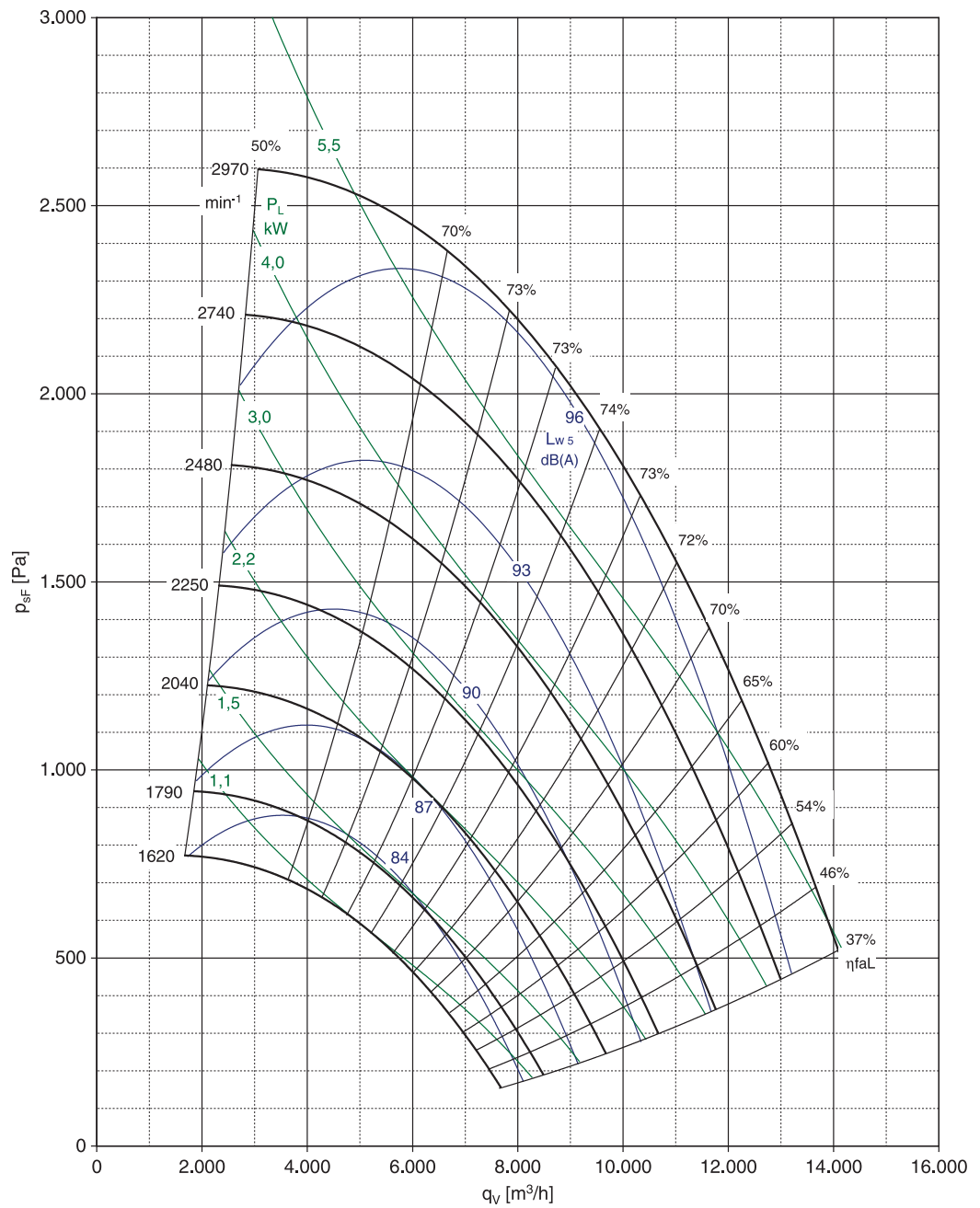
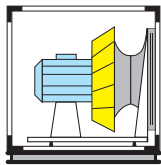

315 mm

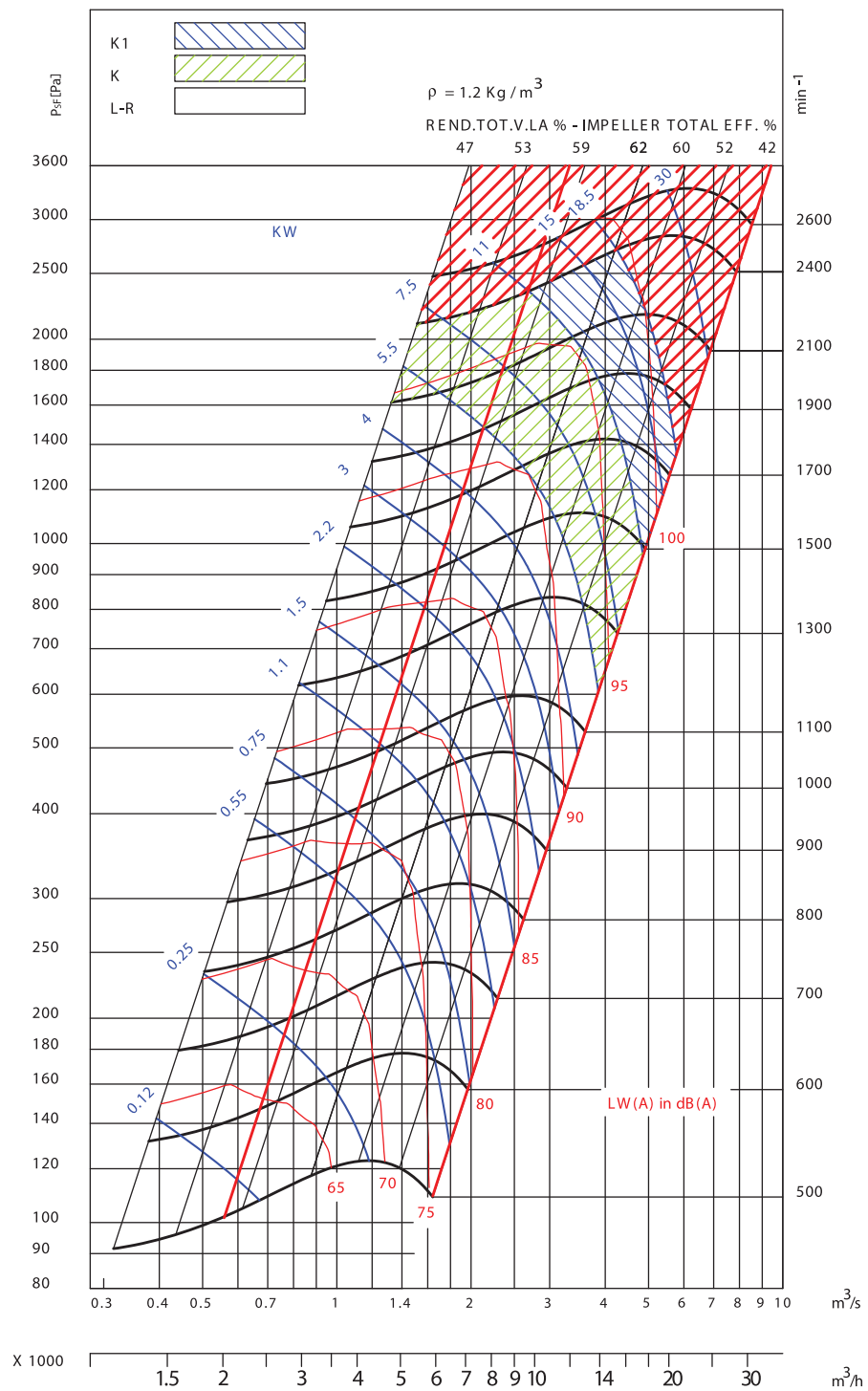
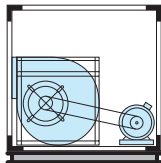

FAN CURVES (AV 15)

560 mm

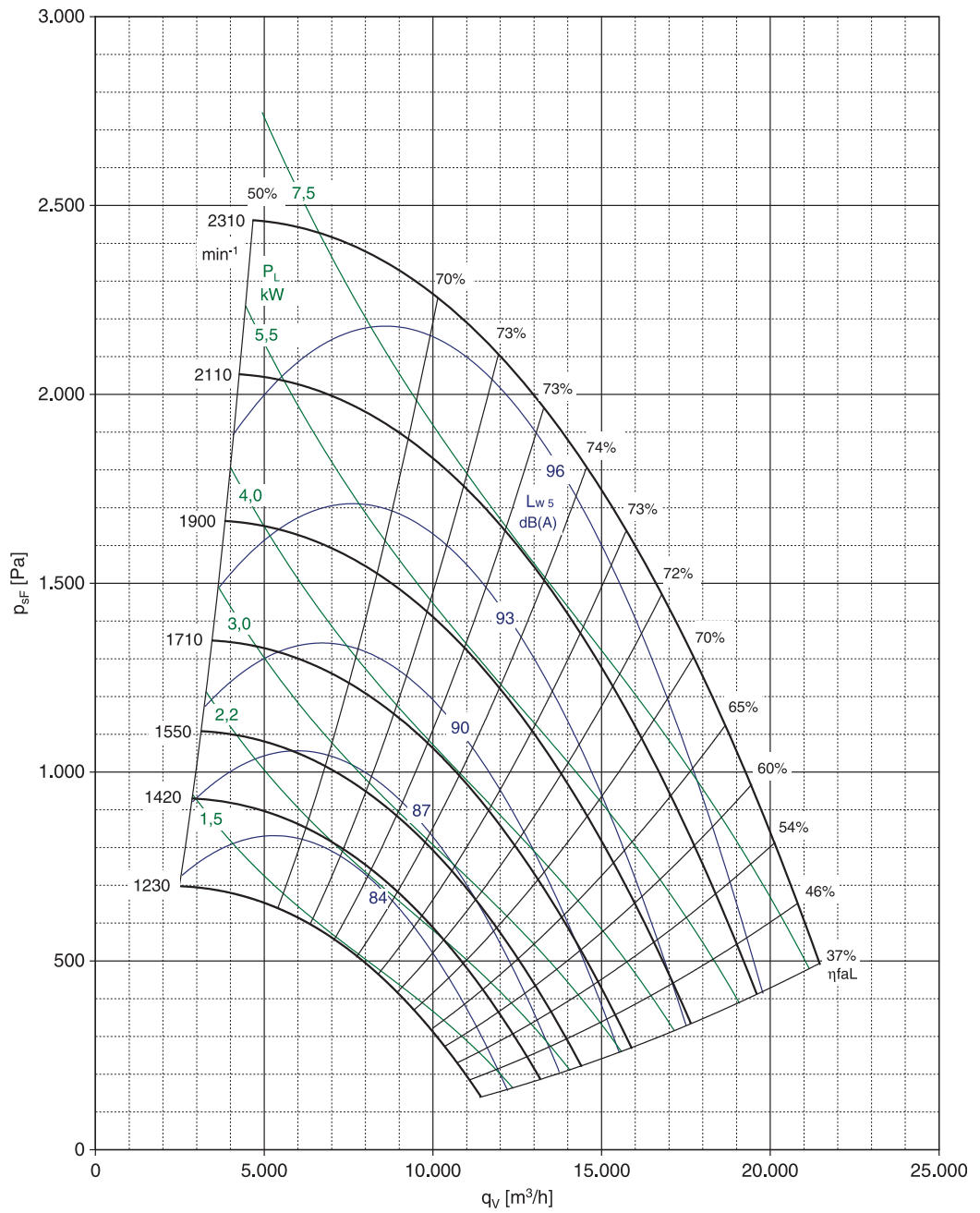
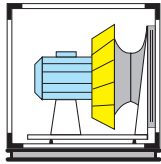

450 mm

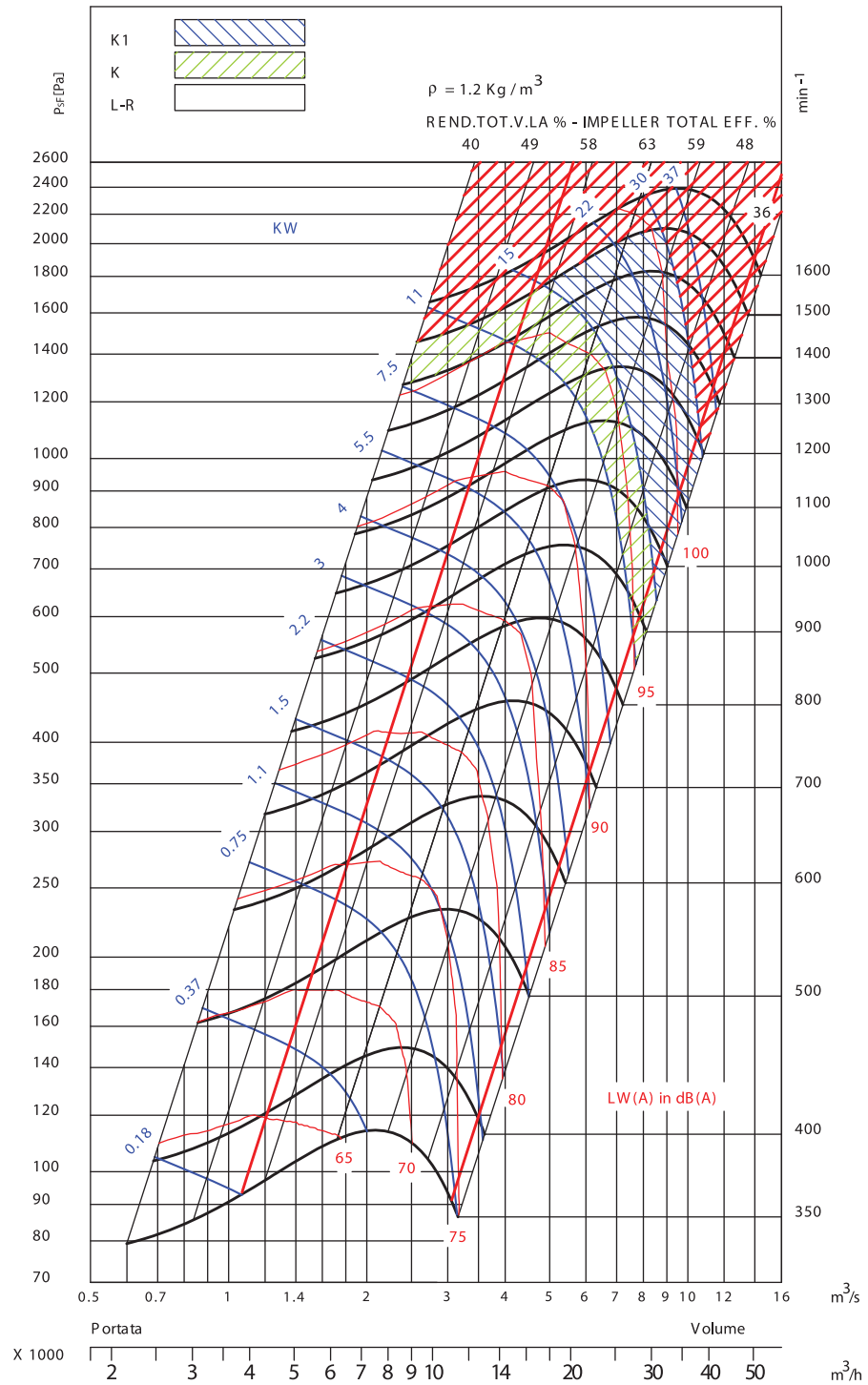
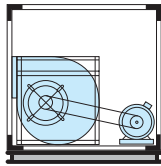

FAN CURVES (AV 20)

630 mm

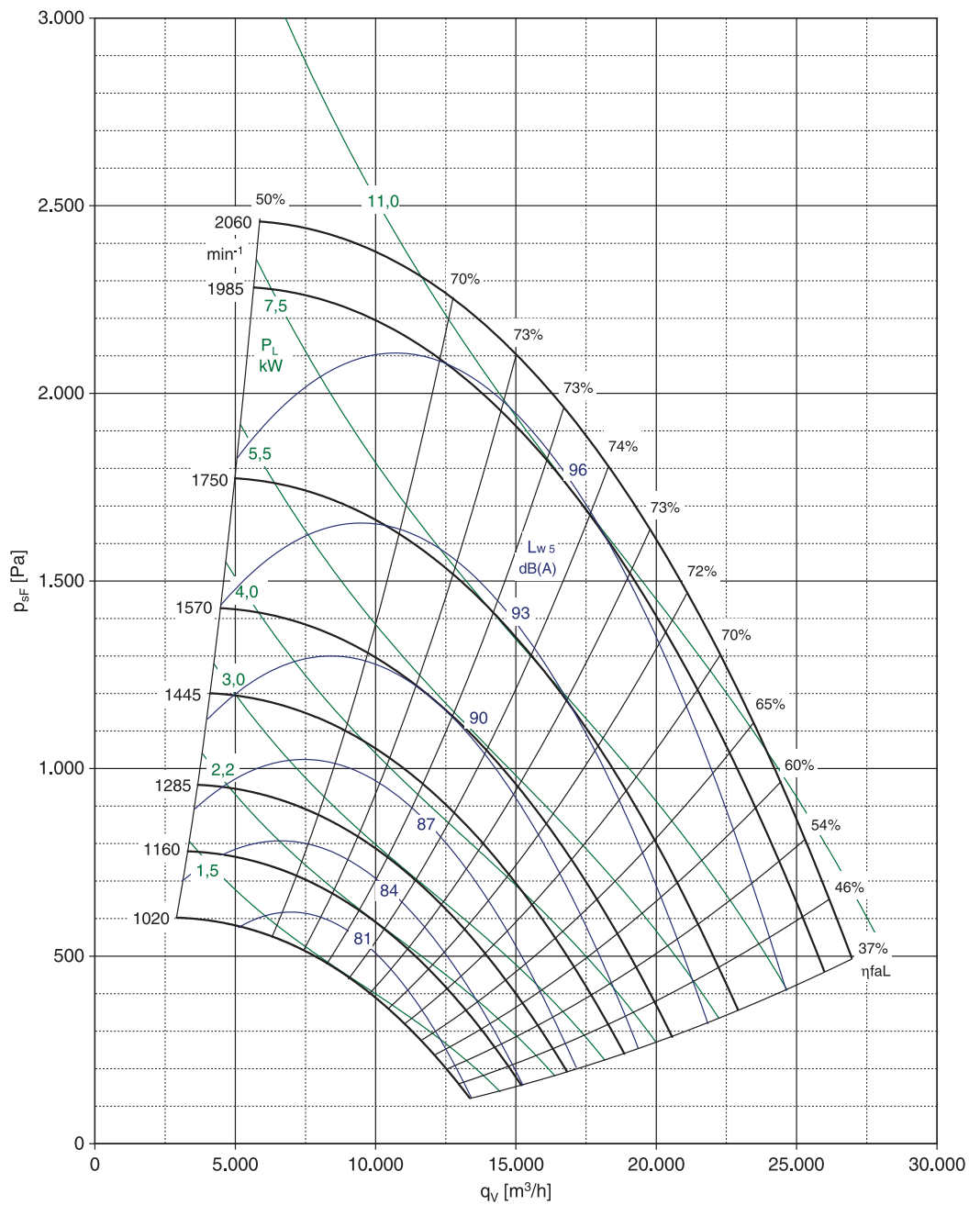
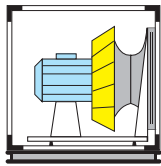

500 mm

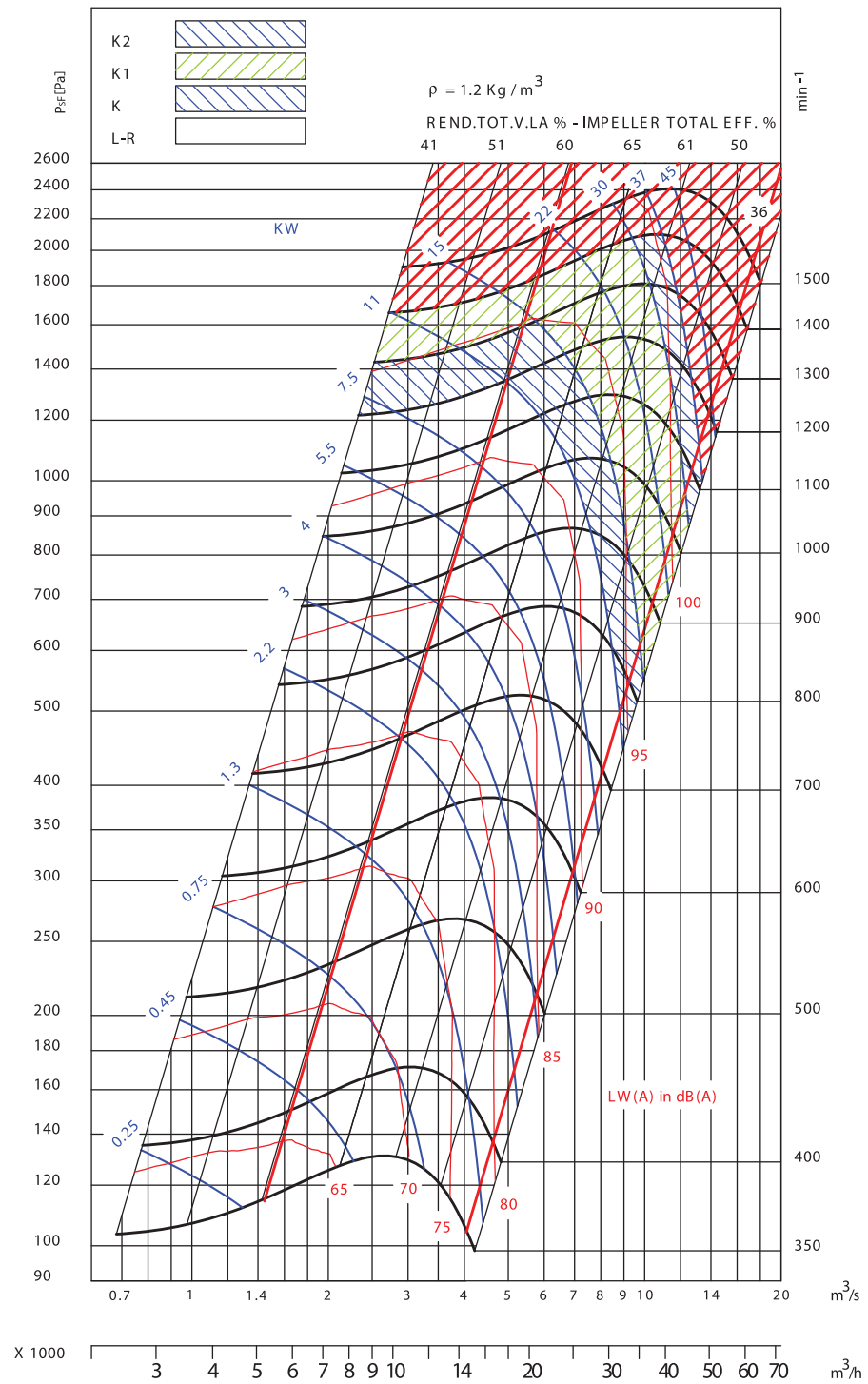
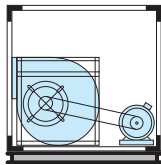

FAN CURVES (AV 27)

2 X 560 mm

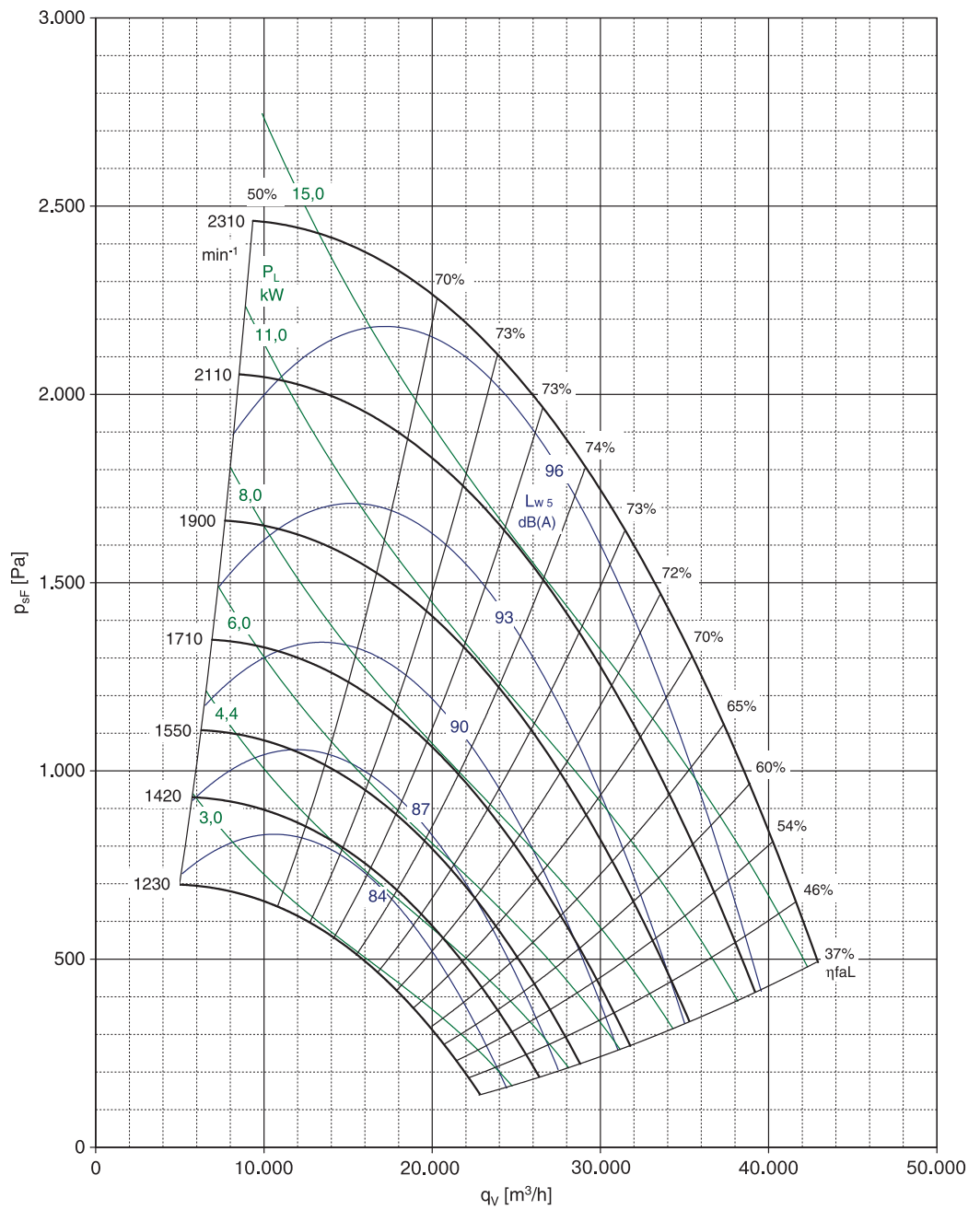
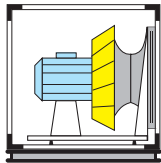

630 mm

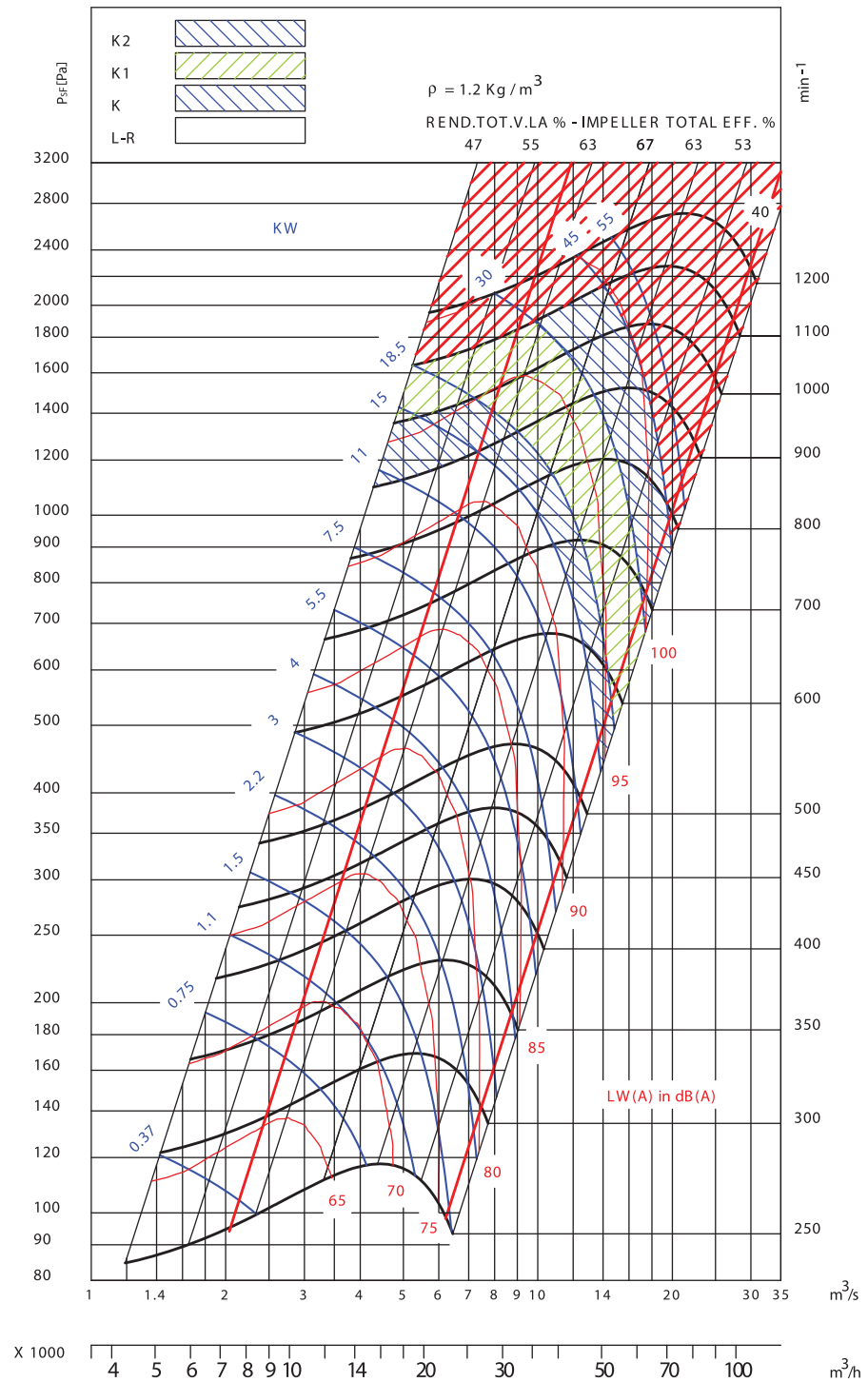
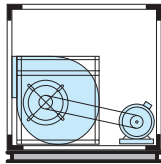

FAN CURVES (AV 35)

2 X 630 mm

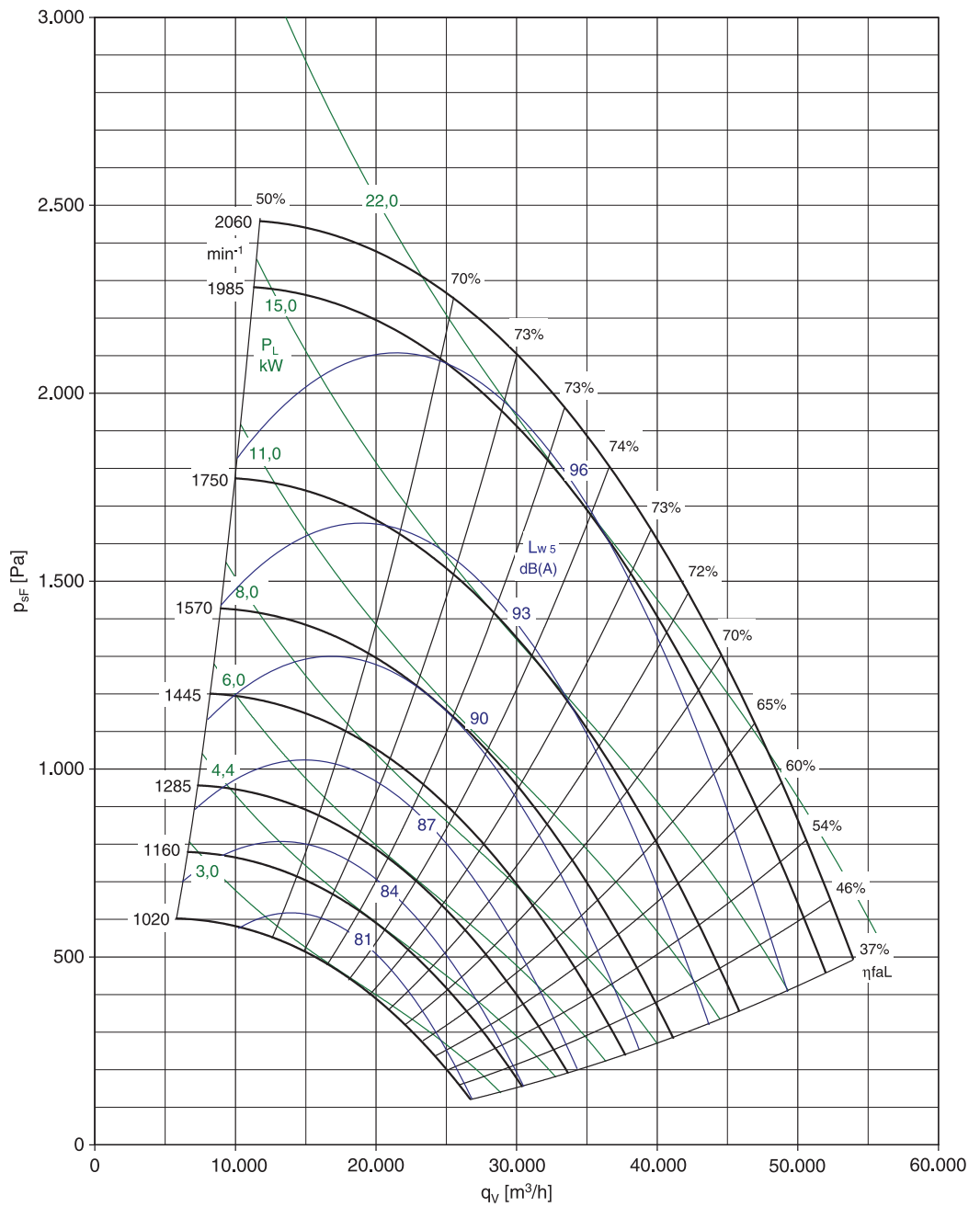
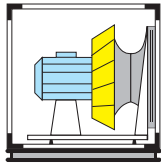

710 mm

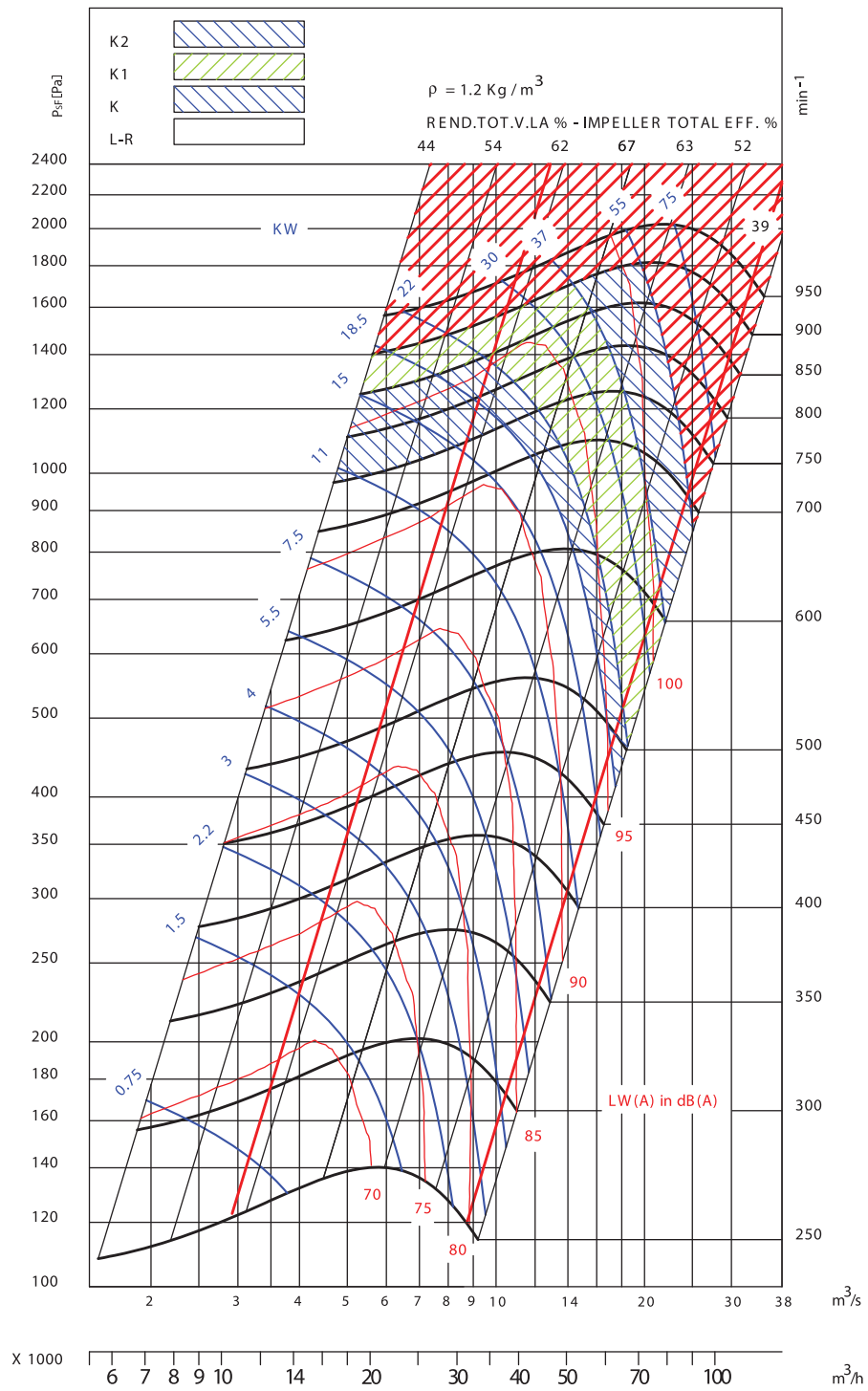
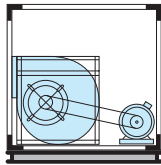

SECTIONS DESCRIPTION



Indoor and outdoor versions

By customer request the units can be manufactured for indoor or outdoor mounting. Indoor units are designed for constant operation in ambient air temperature from -10 till 40 °C. Outdoor-type units operate constantly at temperature of external air between -40 till 40 °C.

Sections have standard connection dimensions so they can be delivered separately.

Airtight casing

All sections are manufactured using aluminum frames with double skinned aluminum-zinc panels insulated with 50mm mineral wool. Each section is supported by a steel frame. Sections are connected to each other by means of steel angles bolted together.

Locks and handles are made of durable plastic ensuring safe and easy service access.

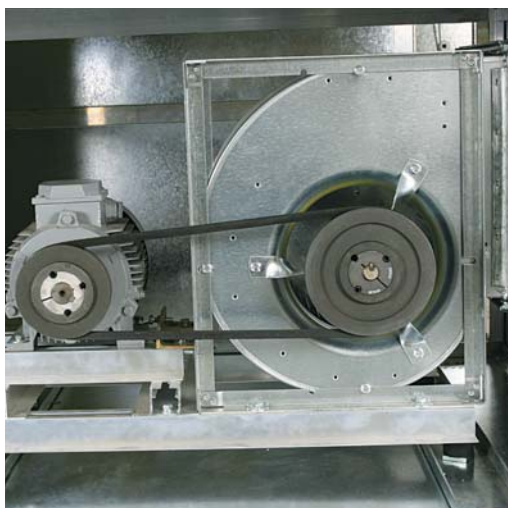

Belt-driven fan section

Fan sections can be supplied with belt-driven snail-type centrifugal fans or plug fans.

Belt-driven fan sections are equipped with highly efficient (up to 82%) fans in soundproof body. Impellers with forward or backward curved blades are available. Fans can be fitted with frequency inverters or transformers to control the airflow. Speed can also be changed by changing fan pulleys manually. Fans together with motors are mounted on durable basic frame with rubber vibration dampers.



Plug fan section

Plug fan sections are supplied with direct-driven plug fans. The advantages of this fan are high efficiency and very quiet operation. Fans are equipped with one-speed motor and can be optionally supplied with frequency inverter for soft starting and speed control. Plug fans are the most suitable solution in systems where variable air flow is required. Fans together with motors are mounted on durable basic frame with rubber vibration dampers. As well an inlet fitting is connected to the frame of the section through vibration damper to prevent any vibrations.

SECTIONS DESCRIPTION



Filter section

For clearing particle contaminants from incoming and/or exhaust air the unit can be supplied with filter sections. These sections are equipped with bag-type or panel filter elements providing the required filtration degree. Filter quality and efficiency comply with requirements of EN 779 and EN 1882 (see the table below) It is recommended to install coarse filters before heat exchangers to prevent contamination and increase efficiency. Where higher-class filters are used, it is recommended to install a lower-class pre-filter as an inexpensive filter to capture bulk particulate and extend the life of the more expensive final filter. Two filters in this case can be installed in one section.

Filters are mounted on slide-out frames with handles so they can be easily removed for cleaning or changing.

Application	Ranking					Efficiency
		DIN 24 185 DIN 24 184	EN 779	EUROVENT 4/5	EN 1882	
A coarse filtration in premises where high air quality is not required.	coarse filters	EU 1	G1	EU 1	-	A (%)
Pre-filtration before heat exchangers, fine or HEPA filters, refrigeration equipment etc.		EU 2	G2	EU 2	-	65
		EU 3	G3	EU 3	-	80
		EU 4	G4	EU 4	-	90
The lower-class air filtration in working and living spaces.	fine filters	EU 5	F5	EU 5	-	E (%)
Premises with high environmental quality requirements such as restaurants high-class hotels, museums etc.		EU 6	F6	EU 6	-	60
		EU 7	F7	EU 7	-	80
		EU 8	F8	EU 8	-	90
Hospital rooms (except sterile rooms); pharmaceutical industries, etc.		EU 9	F9	EU 9	-	95
Operating rooms and other sterile premises.	high efficiency particulate absorbing (HEPA) filters	-	-	-	EU 10	C (%) 97
		-	-	-	EU 11	99
		-	-	-	EU 13	99,99
		-	-	-	EU 14	99,999

SECTIONS DESCRIPTION



Silencer section

The aim of splitter silencers is to reduce noise produced by fan. The splitters are constructed from a single galvanized steel frame in which several layers of glass or mineral wool is included. Splitters have spatial wear-resistant coating to protect the sound-absorbing material. That makes dry cleaning by means of brush or vacuum cleaner possible. Section is supplied with an inspection door to make service access easy.



Automatic air damper section

Air dampers air impermeability corresponds with class 3 EN 1751. Dampers are made of aluminum leaves rotating in opposite directions with good aerodynamic characteristic. Rubber sealing between leaves and the frame is made to ensure the firm contact. For operation in cold climate an electric heating is available as an option. Smooth regulation is made by means of plastic gear drive rotated by BELIMO actuator with spring return.

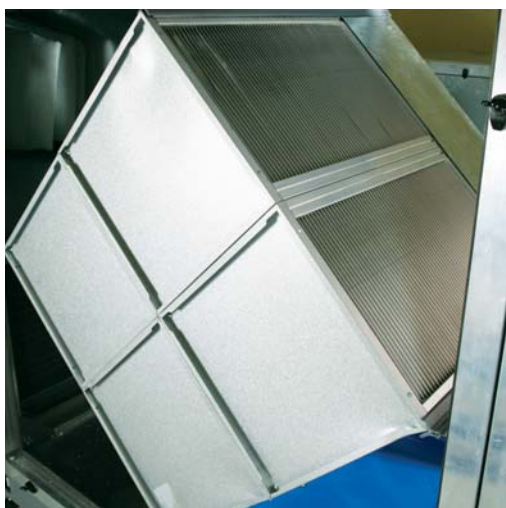

Plate Heat Recovery Section

Heat recovery section is intended to use the energy of leaving air for heating the incoming air without any mixing of these two air streams. The efficiency of plate heat recovery section can reach 85%. This translates into huge savings of energy and money.

Air-to-air heat exchanger block is manufactured from aluminum plates fixed in a frame and sealed with heat-resistant sealing to prevent inlet and outlet air mixing.

The unit is equipped with a drain pan for condensed water drainage. To prevent icing between plates of the heat exchanger the section is fitted with an automatic by-pass air damper at air supply side. The damper is driven by BELIMO actuator, and opens automatically for a short period of time at a signal of the thermal sensor. When the damper is opened the external cold air moves through the damper while extract air still moves through heat recovery element warming it up.

The plate heat exchanger has a simple design and doesn't require periodic service.



Drain pan

Drain pan is installed for draining the water condensed from exhaust air in heat recovery sections.

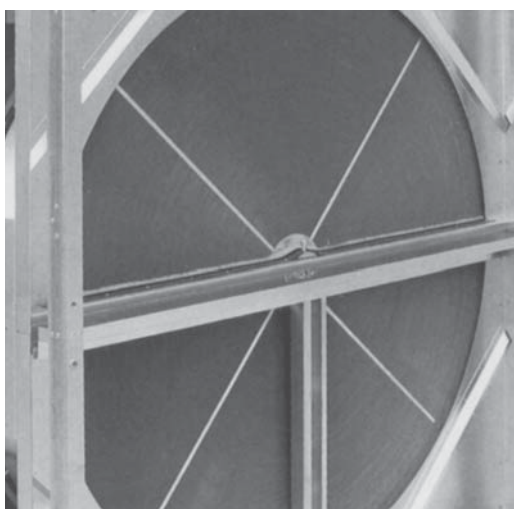

Rotary Heat Recovery Section

The rotating wheel heat exchanger is composed of a rotating cylinder filled with thin wavy aluminum tape resulting in a large surface area. The surface area is the medium for the sensible energy transfer. As the wheel rotates between the supply and exhaust air streams it picks up heat energy and releases it into the colder air stream. Heat exchanger is supplied with effective brush seal placed around the rotor in order to minimize air leaks. Rotors are available with fixed or variable rotation speed. Variable speed of rotation is achieved by using electronic speed regulator giving ability to set the required temperature conditions.

SECTIONS DESCRIPTION



Electric Heating Section

The Electric Heating Section is used for incoming air heating. Electric heating element is manufactured from heat-resistant galvanized steel and have ribbed surface. The element is protected from overheating by two thermal switches. The casing is manufactured from galvanized steel.



Water Heating Section

Water heaters are intended to heat the incoming air using water or water-based mixtures as a heat medium. Maximum operating water temperatures is 150 °C; Water heater is composed of several rows of copper pipes finned with aluminum plates assembled in stainless steel housing.



Cooling Section

Cooling sections are used to chill the incoming air in the summer. We have two different types of cooling batteries: water cooling batteries and evaporators for vapor-compression systems. Casing is made from galvanized steel. Battery is made from copper tubes and aluminum fins. Section is equipped with drain pan. Standard section is also fitted with droplet separator. Aluminum fins can be covered with special corrosion proof layer for operation in aggressive atmosphere conditions. For operation in marine climate fins are manufactured from aluminum-magnesium compound.

SECTIONS DESCRIPTION



Empty (Inspection) Section

A section made of empty casing with inspection door is optionally installed between components requiring regular service access. It is optionally fitted with inspection window and inside lighting. An empty section without a door is usually mounted in case of farther installation of other section instead of it.



Droplet separator

Droplet separator is intended to prevent condensed water drops from getting into the duct.



Control system

Control system is based on a freely-programmable controller working together with a remote control panel. Convenient and simple adjustment procedure is herewith provided for operating conditions of ventilation systems and air conditioning. The controller is compatible with building management systems. The controller is designed to meet all the common requirements to the control system.

Remote control panel

Units are optionally equipped with the control panel providing main control functions depending on a type of the unit, such as setting up the airflow rate, air parameters, error messages, operation by schedule etc.

The control system can be arranged to operate in a way the most suitable for a particular application.

The control system optionally provides operating in multizone systems. The multizone system supplies several zones from a single, centrally located AHU.

It is possible to install a CO₂ sensor in each zone. The control system will check CO₂ level and regulate an airflow in each zone individually.

Standard solutions of higher-level control system arrangement

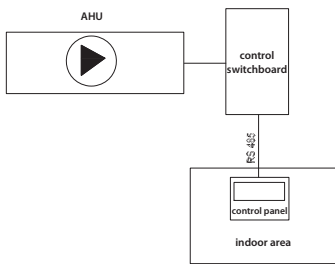

1. Standart control system arrangement with one AHU and one control panel

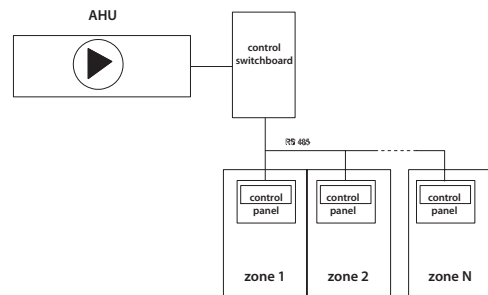

2. Several control panels operating with one AHU

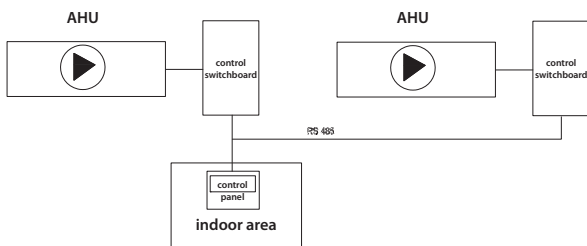

3. A control system using one control panel to control several units

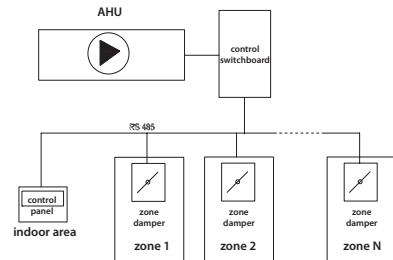

4. Multizone system

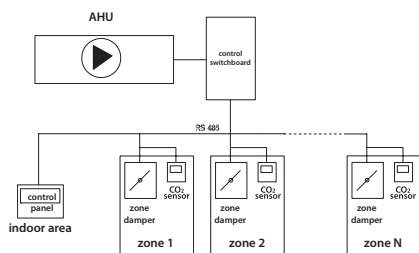

5. Multizone system with CO₂ sensors



STANDARD CONTROL SYSTEM EXAMPLES

Air handling unit with water heater, plate heat recovery section and evaporator section

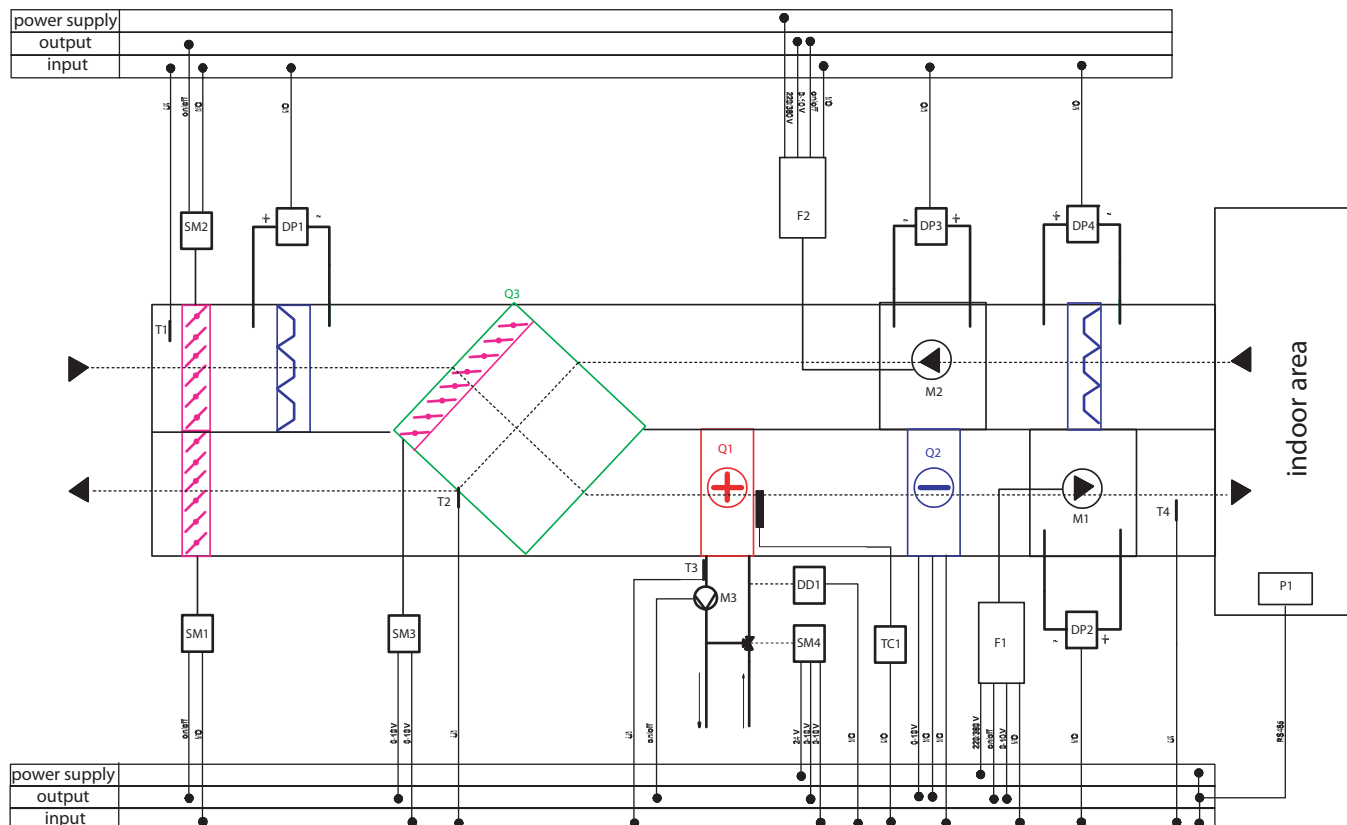

Legend:

- DD1 - heater inlet water pressure relay
- DP1 - differential pressure switch on inlet air filter
- DP2 - differential pressure switch on supply fan
- DP3 - differential pressure switch on exhaust fan
- DP4 - differential pressure switch on exhaust air filter
- F1 - supply fan speed controller (frequency inverter or thyristor speed controller)
- F2 - exhaust fan speed controller (frequency inverter or thyristor speed controller)
- Q1 - water heater
- Q2 - evaporator (cooling battery)
- Q3 - plate air-to-air heat exchanger
- SM1 - outlet damper actuator
- SM2 - supply damper actuator
- SM3 - by-pass damper actuator (in heat recovery section)
- SM4 - 3-way valve actuator (water heaters mixing set)
- M1 - supply fan motor
- M2 - exhaust fan motor
- M3 - circulation pump (water heaters mixing set)
- P1 - remote control panel
- T1 - external air temperature sensor
- T2 - plate heat exchanger temperature sensor (ice detection)
- T3 - outlet water temperature sensor (heating battery)
- T4 - prepared air temperature sensor

STANDARD CONTROL SYSTEM EXAMPLES

Air handling unit with water heater, plate heat recovery section and water heating section

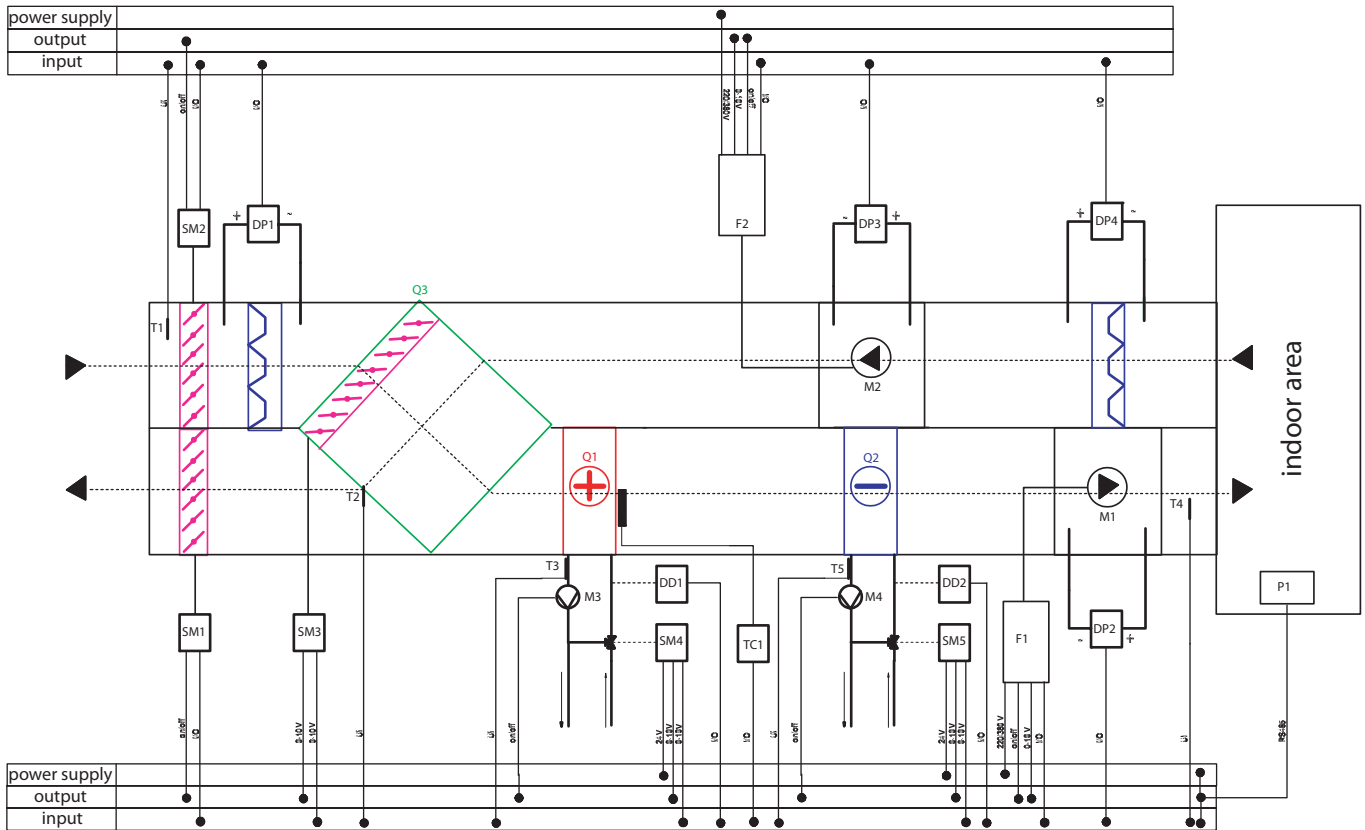

Legend:

- DD1 - heater inlet water pressure switch
- DD2 - cooling battery water pressure switch
- DP1 - differential pressure switch on inlet air filter
- DP2 - differential pressure switch on supply fan
- DP3 - differential pressure switch on exhaust fan
- DP4 - differential pressure switch on exhaust air filter
- F1 - supply fan speed controller (frequency inverter or thyristor speed controller)
- F2 - exhaust fan speed controller (frequency inverter or thyristor speed controller)
- Q1 - water heater
- Q2 - cooling battery
- Q3 - plate air-to-air heat exchanger
- SM1 - exhaust damper actuator
- SM2 - supply damper actuator
- SM3 - by-pass damper actuator (in heat recovery section)
- SM4 - 3-way valve actuator (water heaters mixing set)
- SM5 - 3-way valve actuator (cooling battery mixing set)
- M1 - supply fan motor
- M2 - exhaust fan motor
- M3 - circulation pump (water heaters mixing set)
- M4 - circulation pump (cooling battery mixing set)
- P1 - remote control panel
- T1 - outdoor air temperature sensor
- T2 - plate heat exchanger temperature sensor (ice detection)
- T3 - outlet water temperature sensor (heating battery)
- T4 - prepared air temperature sensor
- T5 - outlet water temperature sensor (cooling battery)
- TC1 - "battery freezing hazard" switch

Air handling unit with electric heater, plate heat recovery section and evaporator section

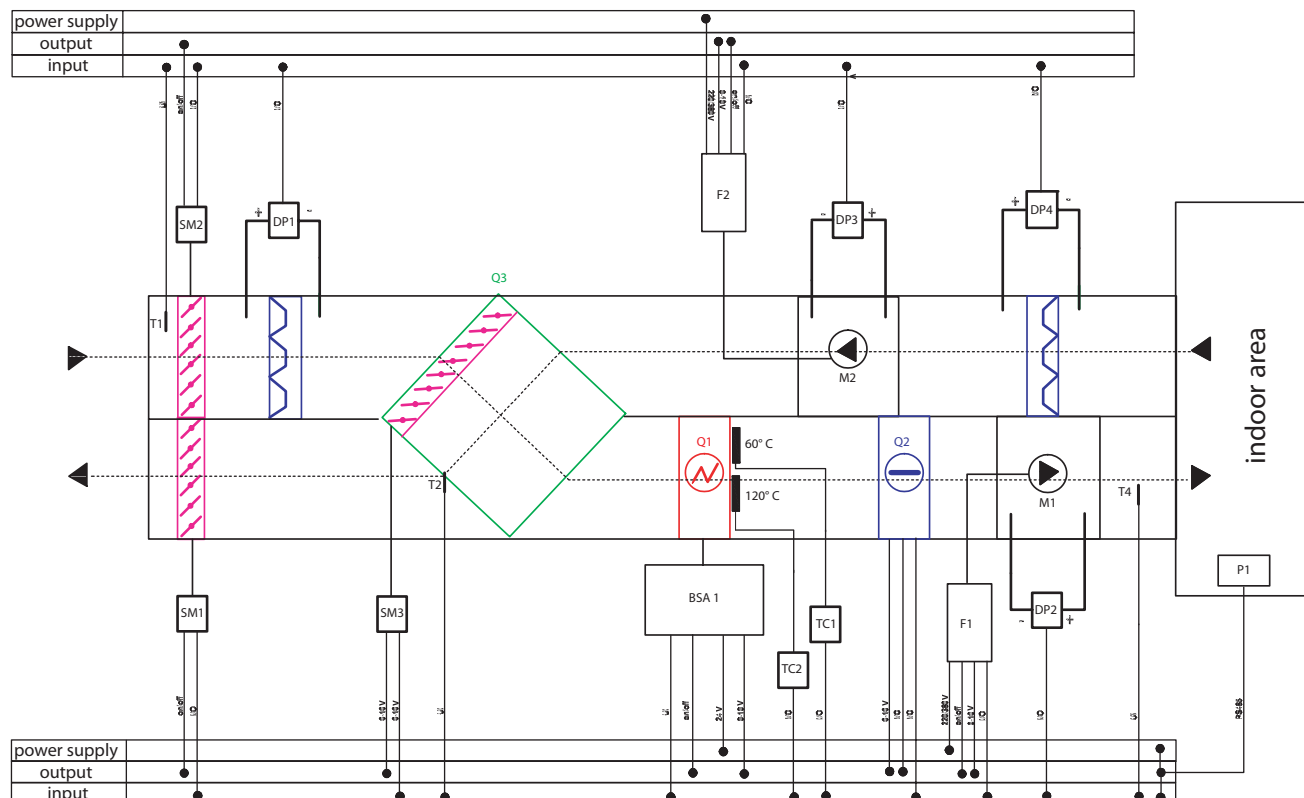

Legend:

- BSA1 - heater power controller
- DP1 - differential pressure switch on inlet air filter
- DP2 - differential pressure switch on supply fan
- DP3 - differential pressure switch on exhaust fan
- DP4 - differential pressure switch on exhaust air filter
- F1 - supply fan speed controller (frequency inverter or thyristor speed controller)
- F2 - exhaust fan speed controller (frequency inverter or thyristor speed controller)
- Q1 - water heater
- Q2 - evaporator (cooling battery)
- Q3 - plate air-to-air heat exchanger
- SM1 - exhaust damper actuator
- SM2 - supply damper actuator
- SM3 - by-pass damper actuator (in heat recovery section)
- M1 - supply fan motor
- M2 - exhaust fan motor
- P1 - remote control panel
- T1 - outdoor air temperature sensor
- T2 - plate heat exchanger temperature sensor (ice detection)
- T4 - prepared air temperature sensor
- TC1 - "overheating hazard" switch 60° C
- TC2 - "overheating hazard" switch 120° C

STANDARD CONTROL SYSTEM EXAMPLES

Air handling unit with electric heater, plate heat recovery section and evaporator section

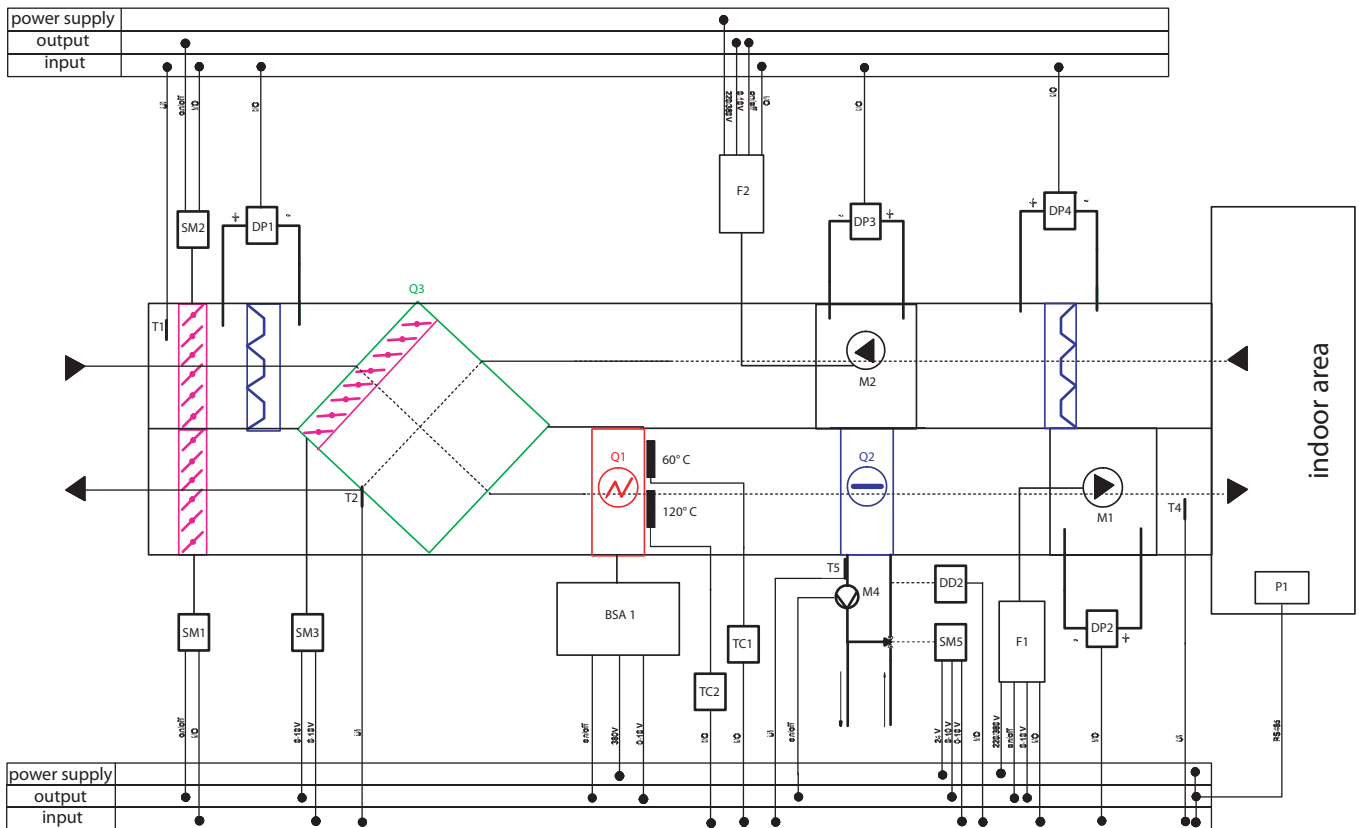

Legend:

- BSA1 – heater power controller
- DD2 – cooling battery water pressure switch
- DP1 – differential pressure switch on supply filter
- DP2 – differential pressure switch on supply fan
- DP3 – differential pressure switch on exhaust fan
- DP4 – differential pressure switch on exhaust filter
- F1 – supply fan speed controller (frequency inverter or thyristor speed controller)
- F2 – exhaust fan speed controller (frequency inverter or thyristor speed controller)
- Q1 – electric heater
- Q2 – cooling battery
- Q3 – plate heat recovery section
- SM1 – exhaust damper actuator
- SM2 – supply damper actuator
- SM5 – 3-way valve actuator (cooling battery mixing set)
- M1 – supply fan motor
- M2 – exhaust fan motor
- M4 – circulation pump (cooling battery mixing set)
- P1 – remote control panel
- RF1 – rotors motor speed controller
- T1 – outdoor air temperature sensor
- T2 – plate heat exchanger temperature sensor (ice detection)
- T4 – prepared air temperature sensor
- T5 – outlet water temperature sensor (cooling battery)
- TC1 – “overheating hazard” switch 60 °C
- TC2 – “overheating hazard” switch 120 °C

Air handling unit with water heater, rotary heat recovery section and water heating section

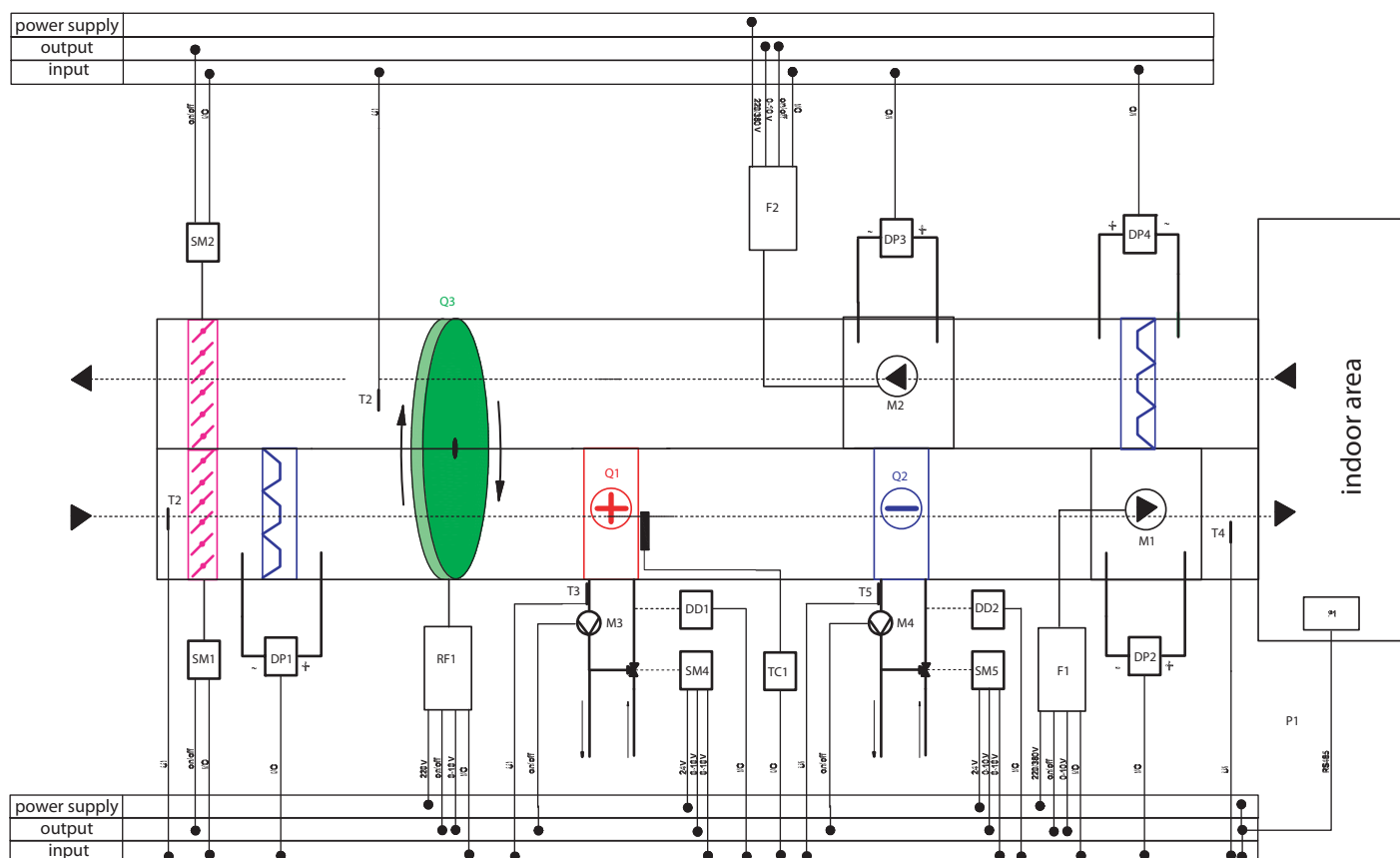

Legend:

- DD1 - heater inlet water pressure switch
- DD2 - cooling battery water pressure switch
- DP1 - differential pressure switch on inlet air filter
- DP2 - differential pressure switch on supply fan
- DP3 - differential pressure switch on exhaust fan
- DP4 - differential pressure switch on exhaust filter
- F1 - supply fan speed controller (frequency inverter or thyristor speed controller)
- F2 - exhaust fan speed controller (frequency inverter or thyristor speed controller)
- Q1 - water heater
- Q2 - cooling battery
- Q3 - rotary heat recovery section
- SM1 - exhaust damper actuator
- SM2 - supply damper actuator
- SM4 - 3-way valve actuator (water heaters mixing set)
- SM5 - 3-way valve actuator (cooling battery mixing set)
- M1 - supply fan motor
- M2 - exhaust fan motor
- M3 - circulation pump (water heaters mixing set)
- M4 - circulation pump (cooling battery mixing set)
- P1 - remote control panel
- RF1 - rotors motor speed controller
- T1 - outdoor air temperature sensor
- T2 - rotary heat exchanger temperature sensor (ice detection)
- T3 - outlet water temperature sensor (heating battery)
- T4 - prepared air temperature sensor
- T5 - outlet water temperature sensor (cooling battery)
- TC1 - "battery freezing hazard" switch

INTEGRATION WITH BUILDING MANAGEMENT SYSTEMS

AHU's integration with centralized building management system gives an ability to provide supervision of several units' performance together with other engineering systems to increase energy efficiency.

One of the main principles of control system is the freedom of choice. The system is based upon the open standards. Controllers used in control system are freely programmable and support the majority of network protocols which are common in building automation, such as TCP/IP, LON.



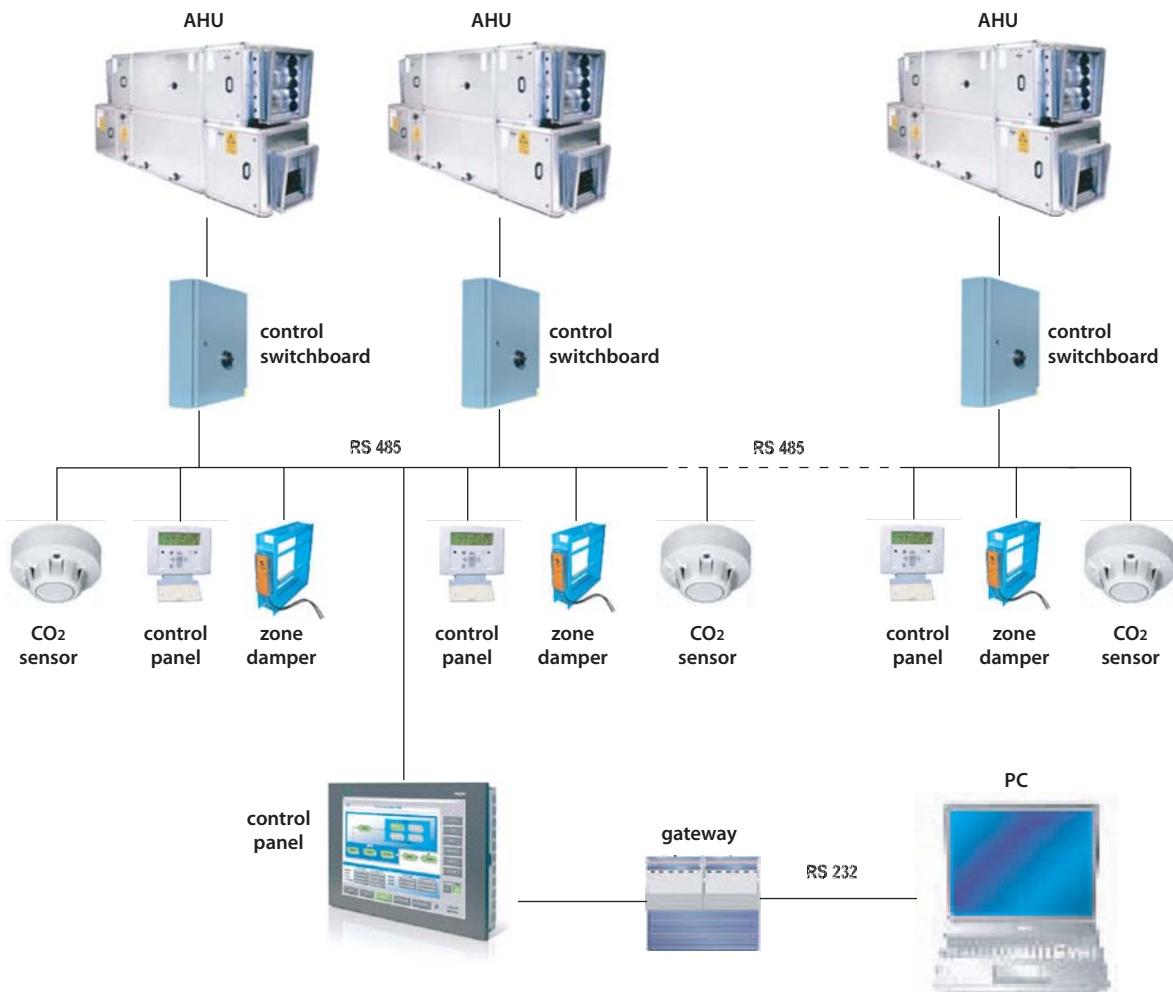



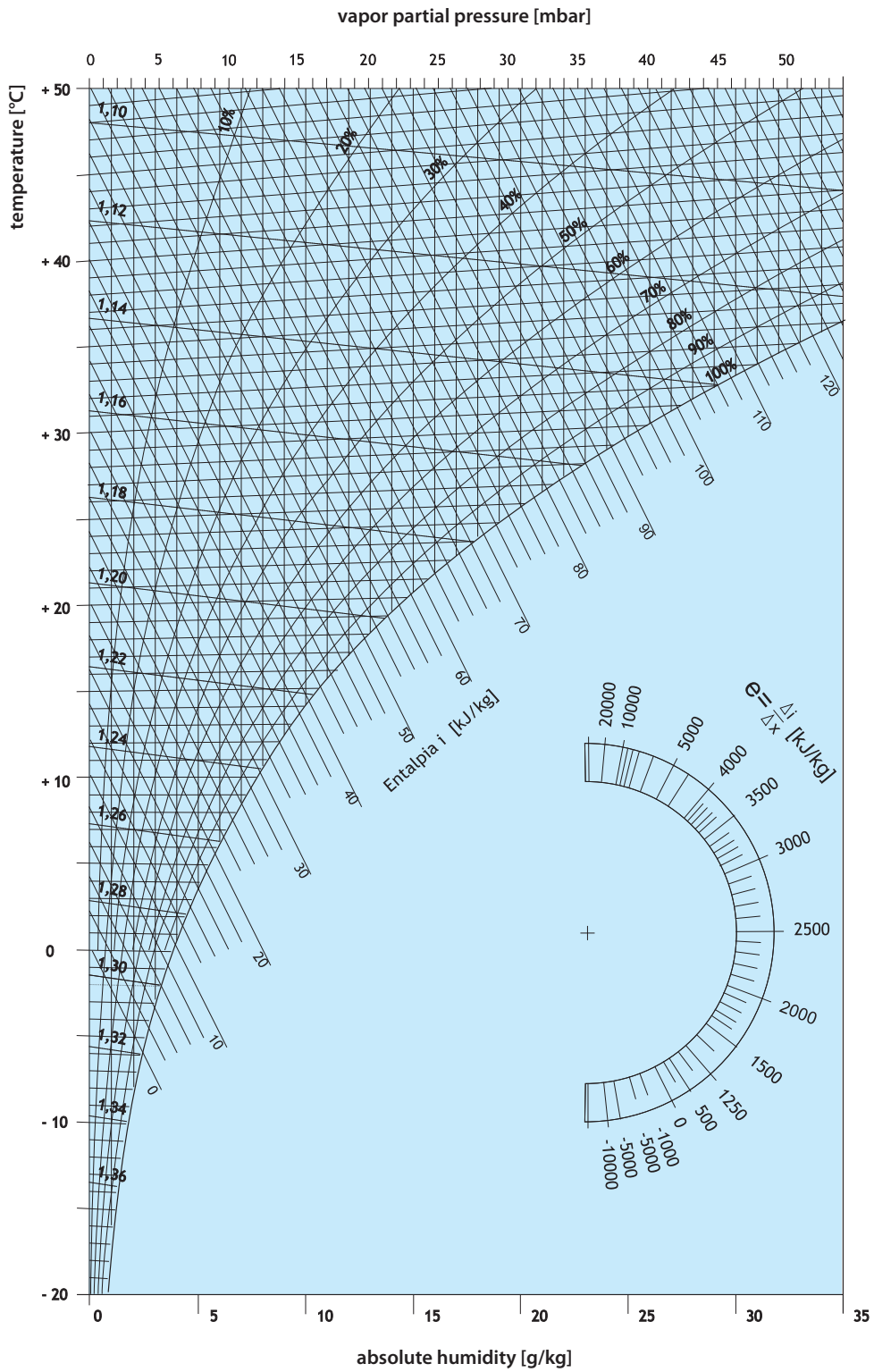

Control system is therefore compatible with a wide range of equipment and software and can be integrated into centralized building management system. Control system has vast communication performance capabilities. Controllers operate well both in slow networks (for example, dial-up), and fast networks (LAN/WAN).



Mollier diagram



NOTES

AirVents technical specification data sheet			
Company	/Building.....	Tell	
Contact person		E-mail:	
Tell.....			www.vents.ua
E-mail.....		"....."200....
General			
Unit:	Exhaust <input type="checkbox"/>	Supply <input type="checkbox"/>	Supply & exhaust <input type="checkbox"/> Supply & exhaust with heat recovery <input type="checkbox"/>
Mounting:	Outdoor <input type="checkbox"/>	Indoor <input type="checkbox"/>	Access side: Left <input type="checkbox"/> Right <input type="checkbox"/>
Supply & exhaust parts:	Lineary <input type="checkbox"/>	Side by side <input type="checkbox"/>	One on other <input type="checkbox"/>
Capacity and pressure		Supply	Exhaust
Capacity	m ³ /hour m ³ /hour
Pressure (system resistance)	Pa Pa
Air parameters		Winter	Summer
Supply	Outdoor air temperature and relative humidity °C % °C %
	Conditioned air temperature and relative humidity °C % °C %
Exhaust	Extract air temperature and relative humidity °C % °C %
	Exhaust air temperature and relative humidity °C % °C %
Sections required			
	Fan	Belt - driven <input type="checkbox"/>	Plug fan <input type="checkbox"/>
	Filter	Supply G4 <input type="checkbox"/> F7 <input type="checkbox"/> Other	Exhaust G4 <input type="checkbox"/> F7 <input type="checkbox"/> Other
	Heater <input type="checkbox"/>	Air temp before / after heater °C/ °C
	Electric <input type="checkbox"/>	Heater power kWt
	Mixing set <input type="checkbox"/>	Water temp before / after heater °C/ °C
	Cooling section <input type="checkbox"/>	Air temp before / after heater °C/ °C
	Freon <input type="checkbox"/>	Heater power kWt
	Mixing set <input type="checkbox"/>	Water temp before / after heater °C/ °C
	Heat recovery section <input type="checkbox"/>	<input type="checkbox"/> Inlet temperature °C <input type="checkbox"/> Outlet temperature
	Plates <input type="checkbox"/>	<input type="checkbox"/> Inlet humidity % <input type="checkbox"/> Outlet humidity
	Rotor <input type="checkbox"/>	<input type="checkbox"/> Efficiency	
	Silencer <input type="checkbox"/>	Supply <input type="checkbox"/>	1200 mm long <input type="checkbox"/> ; other
		Exhaust <input type="checkbox"/>	
	Air damper <input type="checkbox"/>	Supply <input type="checkbox"/>	Exhaust <input type="checkbox"/>
	Mixing section <input type="checkbox"/>	Sirculating air %
		Inlet air temperature °C
		Inlet air humidity °C
Accessories:	Flexible connection (inlet) <input type="checkbox"/>	Flexible connection (outlet) <input type="checkbox"/>	Mounting base frame <input type="checkbox"/>
Controll system	<input type="checkbox"/>		
Additional information:			

